

PA34

FEATURES

Not recommended for new design in.

- **LOW COST**
- **WIDE COMMON MODE RANGE** Includes negative supply
- **WIDE SUPPLY VOLTAGE RANGE**
Single supply: 5V to 40V
Split supplies: $\pm 2.5V$ to $\pm 20V$
- **HIGH EFFICIENCY** — $|V_s - 2.8V|$ at 2.5A typ
- **HIGH OUTPUT CURRENT** — 2.5A min
- **INTERNAL CURRENT LIMIT**
- **LOW DISTORTION**
- **PACKAGING OPTIONS**
7 TO-220 Plastic Package (PA34CD)
7 TO-220 with Staggered Lead Form (PA34CX)
7 DPAK Surface Mount Package (PA34CC)

APPLICATIONS

- **HALF & FULL BRIDGE MOTOR DRIVERS**
- **AUDIO POWER AMPLIFIER**
- **IDEAL FOR SINGLE SUPPLY SYSTEMS**
5V Peripherals, 12V Automotive, 28V Avionic

DESCRIPTION

The PA34 consists of a monolithic power operational amplifier in three standard package designs. The surface mount version of the PA34, the PA34CC, is an industry standard non-hermetic plastic 7-pin DPAK. The through hole versions of the PA34, the PA34CD and PA34CX, are industry standard non-hermetic plastic 7-pin TO-220 packages. The PA34CX is a staggered lead formed PA34CD and offers industry standard 100 mil spacing. This allows for easier PC board layout. (Please reference to the lead form datasheet drawing LF005 for package dimensions of the PA34CX.)

The wide common mode input range includes the negative rail, facilitating single supply applications. It is possible to have a "ground based" input driving a single supply amplifier with ground acting as the "second" or "bottom" supply of the amplifier.

The output stage is also well protected. They possess internal current limit circuits. While the device is well protected, the Safe Operating Area (SOA) curve must be observed. Proper heatsinking is required for maximum reliability.

The monolithic amplifier is directly attached to the metal tabs of the PA34CC, PA34CD, and PA34CX. The metal tabs are directly tied to -Vs.

EQUIVALENT SCHEMATIC

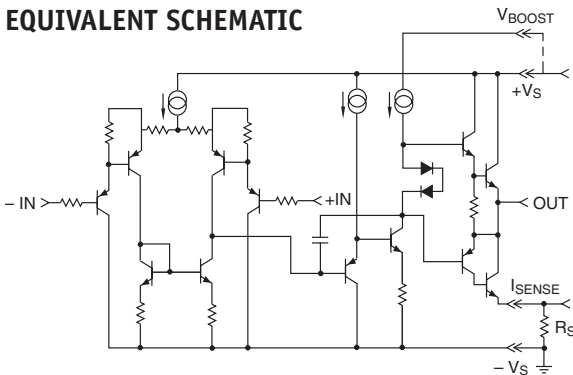

TYPICAL APPLICATION

Ref: APPLICATION NOTE 20: "Bridge Mode Operation of Power Amplifiers"

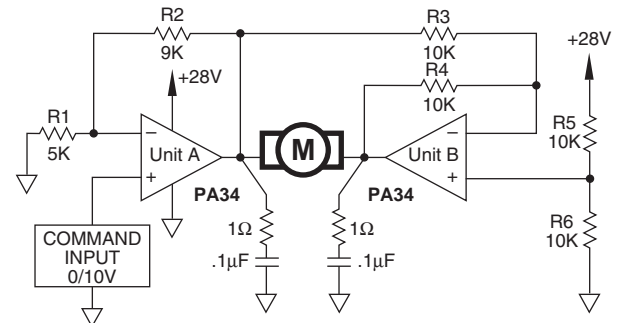

BIDIRECTIONAL MOTOR DRIVE

R1 and R2 set up amplifier A in a non-inverting gain of 2.8. Amp B is set up as a unity gain inverter driven from the output of amp A. Note that amp B inverts signals about the reference node, which is set at mid-supply (14V) by R5 and R6. When the command input is 5V, the output of amp A is 14V. Since this is equal to the reference node voltage, the output of amp B is also 14V, resulting in 0V across the motor. Inputs more positive than 5V result in motor current flow from left to right. Inputs less positive than 5V drive the motor in the opposite direction. (See PA21/25/26/37 Datasheet for additional application description.)

EXTERNAL CONNECTIONS

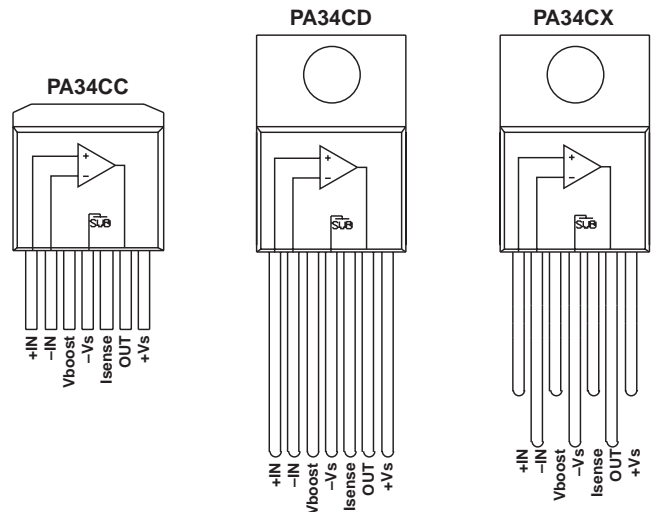

ABSOLUTE MAXIMUM RATINGS

| | |
|--|-----------------|
| SUPPLY VOLTAGE, total | 5V to 40V |
| OUTPUT CURRENT | SOA |
| POWER DISSIPATION, internal | 18.5W |
| INPUT VOLTAGE, differential | $\pm V_S$ |
| INPUT VOLTAGE, common mode | $+V_S, -V_S-5V$ |
| JUNCTION TEMPERATURE, max ¹ | 150°C |
| TEMPERATURE, pin solder—10 sec max | 220°C |
| TEMPERATURE RANGE, storage | -65°C to 150°C |
| OPERATING TEMPERATURE RANGE, case | -40°C to 125°C |

SPECIFICATIONS

| PARAMETER | TEST CONDITIONS ² | PA34 | | | UNITS |
|---|---------------------------------|------------------|------------------|----------|------------------|
| | | MIN | TYP | MAX | |
| INPUT | | | | | |
| OFFSET VOLTAGE, initial | | | 1.5 | 10 | mV |
| OFFSET VOLTAGE, vs. temperature | Full temperature range | | 15 | | $\mu V/^\circ C$ |
| BIAS CURRENT, initial | | 35 | 1000 | | nA |
| COMMON MODE RANGE | Full temperature range | $-V_S-3$ | | $+V_S-2$ | dB |
| COMMON MODE REJECTION, DC | Full temperature range | 60 | 85 | | dB |
| POWER SUPPLY REJECTION | Full temperature range | 60 | 80 | | dB |
| GAIN | | | | | |
| OPEN LOOP GAIN | Full temperature range | 80 | 100 | | dB |
| GAIN BANDWIDTH PRODUCT | $A_V = 40dB$ | | 600 | | kHz |
| PHASE MARGIN | Full temperature range | | 65 | | ° |
| POWER BANDWIDTH | $V_{O(P-P)} = 28V$ | | 13.6 | | kHz |
| OUTPUT | | | | | |
| CURRENT, peak | | 2.5 | | | A |
| SLEW RATE | | .5 | 1.2 | | V/ μs |
| CAPACITIVE LOAD DRIVE | $A_V = 1$ | | .22 | | μF |
| VOLTAGE SWING | Full temp. range, $I_O = 100mA$ | $ V_{S1} - 1.0$ | $ V_{S1} - 0.8$ | | V |
| VOLTAGE SWING | Full temp. range, $I_O = 1A$ | $ V_{S1} - 1.8$ | $ V_{S1} - 1.4$ | | V |
| VOLTAGE SWING | $I_O = 2.5A$ | $ V_{S1} - 3.0$ | $ V_{S1} - 2.8$ | | V |
| POWER SUPPLY | | | | | |
| VOLTAGE, V_{SS} ³ | | 5 | 30 | 40 | V |
| CURRENT, quiescent, total | | | 45 | 90 | mA |
| THERMAL | | | | | |
| RESISTANCE, DC junction to case | | | 5.44 | 6.8 | $^\circ C/W$ |
| RESISTANCE, AC junction to case | | | 4.08 | 5.1 | $^\circ C/W$ |
| RESISTANCE, junction to air (CD,CX) | | | 60 | | $^\circ C/W$ |
| RESISTANCE, junction to air (CC) ⁴ | | | 27 | | $^\circ C/W$ |
| TEMPERATURE RANGE, case | Meets full range specifications | -25 | | 85 | $^\circ C$ |

NOTES:

1. Long term operation at the maximum junction temperature will result in reduced product life. Derate internal power dissipation to achieve high MTTF.
2. Unless otherwise noted, the following conditions apply: $\pm V_S = \pm 15V$, $T_C = 25^\circ C$.
3. $+V_S$ and $-V_S$ denote the positive and negative supply rail respectively. V_{SS} denotes the total rail-to-rail supply voltage.
4. Heat tab attached to 3/32" FR-4 board with 2oz. copper. Topside copper area (heat tab directly attached) = 1000 sq. mm, backside copper area = 2500 sq. mm, board area = 2500 sq. mm.

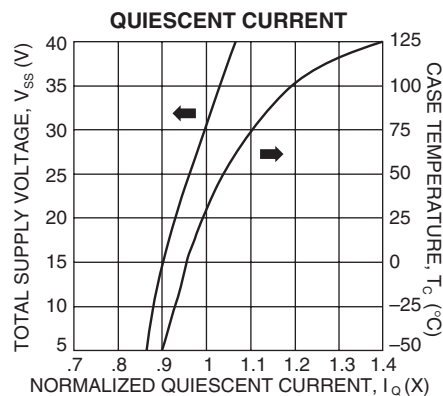
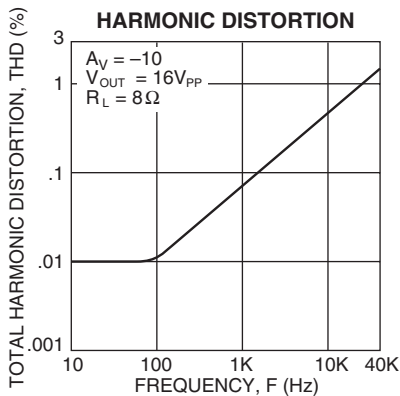
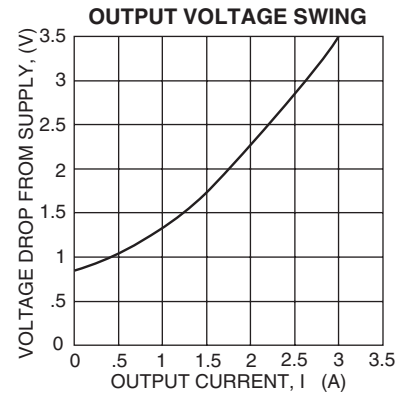
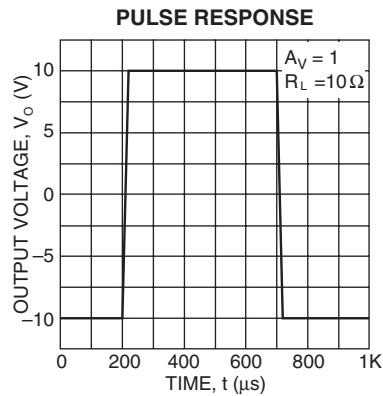
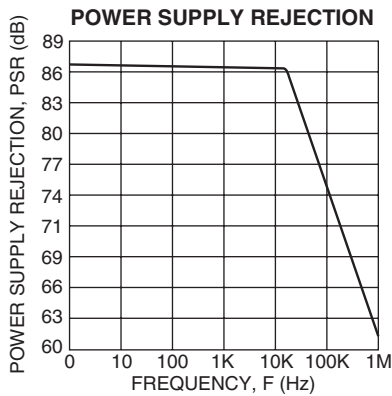
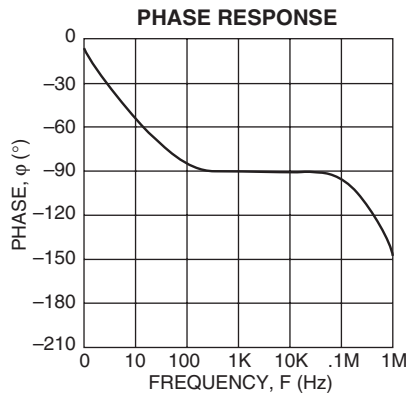
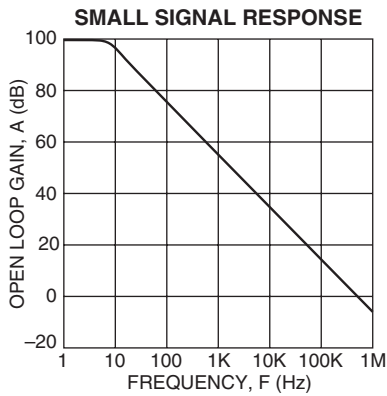
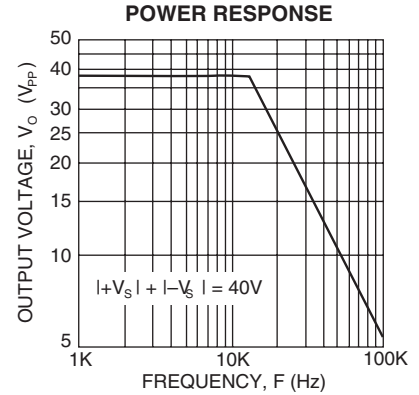
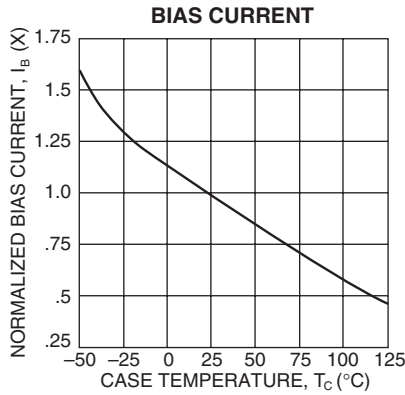
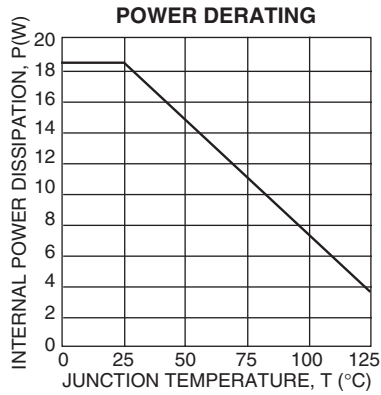

GENERAL

Please read Application Note 1 "General Operating Considerations" which covers stability, supplies, heat sinking, mounting, current limit, SOA interpretation, and specification interpretation. Visit www.apexmicrotech.com for design tools that help automate tasks such as calculations for stability, internal power dissipation, current limit and heat sink selection. The "Application Notes" and "Technical Seminar" sections contain a wealth of information on specific types of applications. Package outlines, heat sinks, mounting hardware and other accessories are located in the "Packages and Accessories" section. Evaluation Kits are available for most Apex product models. Consult the "Evaluation Kit" section for details. For the most current version of all Apex product data sheets, visit www.apexmicrotech.com.

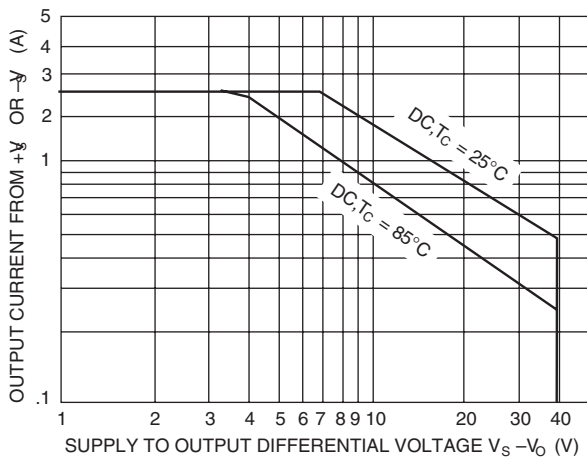

SAFE OPERATING AREA (SOA)

The SOA curves combine the effect of all limits for this power op amp. For a given application, the direction and magnitude of the output current should be calculated or measured and checked against the SOA curves. This is simple for resistive loads but more complex for reactive and EMF generating loads. The following guidelines may save extensive analytical efforts.

Under transient conditions, capacitive and dynamic* inductive loads up to the following maximum are safe:

| $\pm V_S$ | CAPACITIVE LOAD | INDUCTIVE LOAD |
|-----------|-------------------|----------------|
| 20V | 200 μF | 7.5mH |
| 15V | 500 μF | 25mH |
| 10V | 5mF | 35mH |
| 5V | 50mF | 150mH |

* If the inductive load is driven near steady state conditions, allowing the output voltage to drop more than 6V below the supply rail while the amplifier is current limiting, the inductor should be capacitively coupled or the supply voltage must be lowered to meet SOA criteria.

NOTE: For protection against sustained, high energy flyback, external fast-recovery diodes should be used.

MONOLITHIC AMPLIFIER STABILITY CONSIDERATIONS

All monolithic power op amps use output stage topologies that present special stability problems. This is primarily due to non-complementary (both devices are NPN) output stages with a mismatch in gain and phase response for different polarities of output current. It is difficult for the op amp manufacturer to optimize compensation for all operating conditions.

The recommended R-C network of 1 ohm in series with 0.1 μF from output to AC common (ground or a supply rail, with adequate bypass capacitors) will prevent local output stage oscillations.

The amplifiers are internally compensated for unity gain stability, no additional compensation is required.

THERMAL CONSIDERATIONS

The PA34 may require a thermal washer which is electrically insulating since the tab is tied to $-V_S$. This can result in thermal impedances for $R_{\theta CS}$ of up to 1 $^\circ\text{C}/\text{W}$ or greater.

The PA34CC 7-pin DPAK surface mountable package has a large exposed integrated copper heatslug to which the monolithic amplifier is directly attached. The PA34CC requires surface mount techniques of heatsinking. A solder connection to an area of 1 to 2 square inches of foil is recommended for circuit board layouts. This may be adequate heatsinking but the large number of variables involved suggests temperature measurements to be made on the top of the package. Surface mount techniques include the use of a surface mount fan in combination with a surface mount heatsink on the backside of the FR4/PC board. Do not allow the temperature to exceed 85 $^\circ\text{C}$.

MOUNTING PRECAUTIONS

1. Always use a heat sink. Even unloaded, the PA34 can dissipate up to 3.6 watts. A thermal washer or thermal grease should always be used.
2. Avoid bending the leads. Such action can lead to internal damage.
3. Always fasten the tab to the heat sink before the leads are soldered to fixed terminals.
4. Strain relief must be provided if there is any probability of axial stress to the leads.

ADDITIONAL PA34 PIN FUNCTIONS

V_{BOOST}

The V_{BOOST} pin is the positive terminal for the load of the second stage of the amplifier. When that terminal is connected to a voltage greater than $+V_S$ it will provide more drive to the upper output transistor, which is a darlington connected emitter follower. This will better saturate the output transistor.

When V_{BOOST} is about 5 Volts greater than $+V_S$ the positive output can swing 0.5 Volts closer to the rail. This is as much improvement as is possible.

V_{BOOST} pin requires approximately 10–12mA of current. Dynamically it represents 1K Ω impedance. The maximum voltage that can be applied to V_{BOOST} is 40 volts with respect to $-V_S$. There is no limit to the difference between $+V_S$ and V_{BOOST} .

Figure 1 shows a bootstrap which dynamically couples the output waveform onto the V_{BOOST} pin. This causes V_{BOOST} to swing positive from its initial value, which is equal to $+V_S - 0.7 V$ (one diode drop), an amount equal to the output. In other words, if V_{BOOST} was initially 19.3, and the output swings positive 18 Volts, the voltage on the V_{BOOST} pin will swing to $19.3 - 0.7 + 18$ or 36.6. The capacitor needs to be sized based on a 1K Ω impedance and the lowest frequency required by the circuit. For example, 20Hz will require $> 8\mu F$.

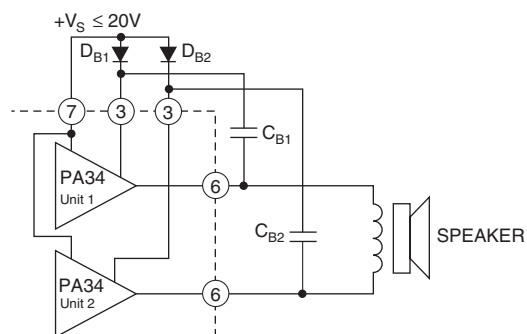

FIGURE 1. SIMPLE BOOTSTRAPPING IMPROVES POSITIVE OUTPUT SWING. TYPICAL CURRENTS ARE 12mA EACH.

ISENSE

The I_{SENSE} pin is in series with the negative half of the output stage only. Current will flow through this pin only when negative current is being outputted. The current that flows in this pin is the same current that flows in the output (if $-1A$ flows in the output, the I_{SENSE} pin will have 1A of current flow, if $+1A$ flows in the output the I_{SENSE} pin will have 0 current flow).

The resistor choice is arbitrary and is selected to provide whatever voltage drop the engineer desires, up to a maximum of 1.0 volt. However, any voltage dropped across the resistor will subtract from the swing to rail. For instance, assume a ± 12 volt power supply and a load that requires $\pm 1A$. With no current sense resistor the output could swing ± 10.2 volts. If a 1 Ω resistor is used for current sense (which will drop 1 Volt at 1 Amp) then the output could swing $+10.2, -9.2$ Volts.

Figure 2 shows the PA34 I_{SENSE} feature being used to obtain a Transconductance function. In this example, amplifier "A" is the master and amplifier "B" is the slave. Feedback from sensing resistors R_S is applied to the summing network and scaled to the inverting input of amplifier "A" where it is compared to the input voltage. The current sensing feedback imparts a Transconductance feature to the amplifiers transfer function. In other words, the voltage developed across the sensing resistors is directly proportional to the output current. Using this voltage as a feedback source allows expressing the gain of the circuit in amperes vs input voltage. The transfer function is approximately:

$$I_L = (V_{IN} - V_{REF}) * R_{IN} / R_{FB} / R_S$$

In the illustration, resistors R_{IN} , R_{FB} and R_S determine gain.

V_{BIAS} should be set midway between $+V_S$ and $-V_S$, V_{ref} is usually ground in dual supply systems or used for level translation in single supply systems.

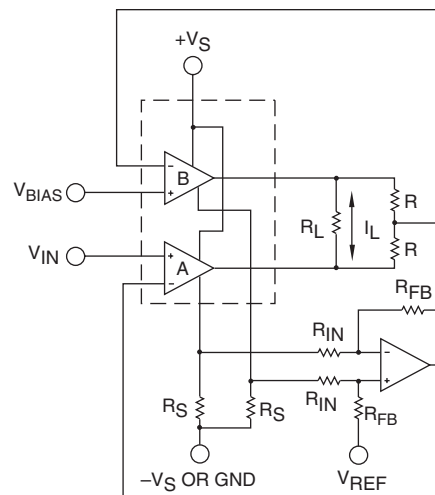

FIGURE 2. I_{SENSE} TRANSCONDUCTANCE BRIDGING AMPLIFIER

APPLICATION REFERENCES:

For additional technical information please refer to the following Application Notes:

- AN 1: General Operating Considerations
- AN 3: Bridge Circuit Drives
- AN 21: Single Supply Operation of Power Amplifiers
- AN 24: Brush Type DC Motor Drive

NOTES: _____
