



STV6432

Audio/Video Output Buffers for STB and DVD Devices

FEATURES

■ VIDEO SECTION

- Y/C/CVBS Inputs
- Y/C Outputs for TV
- 4 CVBS Outputs (for TV, VCR, Aux and RF Modulator)
- 6 dB Gain with Fine Adjustment
- Integrated 150Ω Buffers
- Sync Bottom Clamp on all CVBS/Y And Bias on C Inputs
- Crosstalk: 50 dB (Typ.)
- Bandwidth: 15 MHz

■ AUDIO SECTION

- 1 pair of Stereo Inputs
- 1 pair of Stereo Outputs (TV, VCR, AUX)
- Stereo-to-Mono Capability (RF Mod output)
- 6 dB Gain
- Crosstalk: 80 dB min.

DESCRIPTION

The STV6432 is an audio/video output interface for US STB and DVD.

It adapts in amplitude and impedance the audio and video signals coming from the digital decoder to provide them to the TV set, VCR, Auxiliary and RF modulator.

The video gains are adjustable from 5 dB to 8 dB in steps of 1 dB.

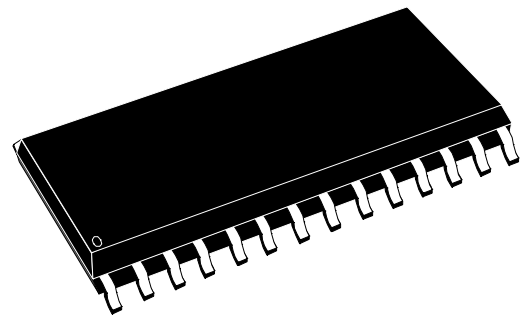

SO28
ORDER CODE: STV6432

TABLE OF CONTENTS

Chapter 1	PIN CONNECTIONS	3
Chapter 2	ELECTRICAL CHARACTERISTICS	5
2.1	Absolute Maximum Ratings	5
2.2	Thermal Data	5
2.3	Supply Section	5
2.4	Audio Section	6
2.5	Video Section	7
2.6	Chroma Section	8
Chapter 3	INPUT/OUTPUT GROUPS	9
Chapter 4	APPLICATION DIAGRAMS	11
Chapter 5	PACKAGE MECHANICAL DATA	13
Chapter 6	REVISION HISTORY	14

1 PIN CONNECTIONS

Figure 1: Pin Connections on SO28 Package

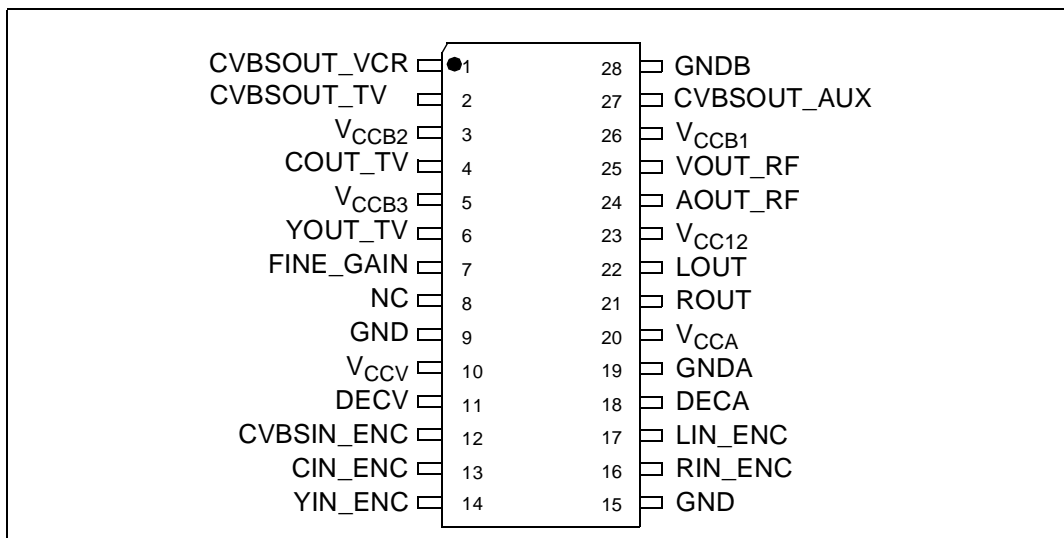
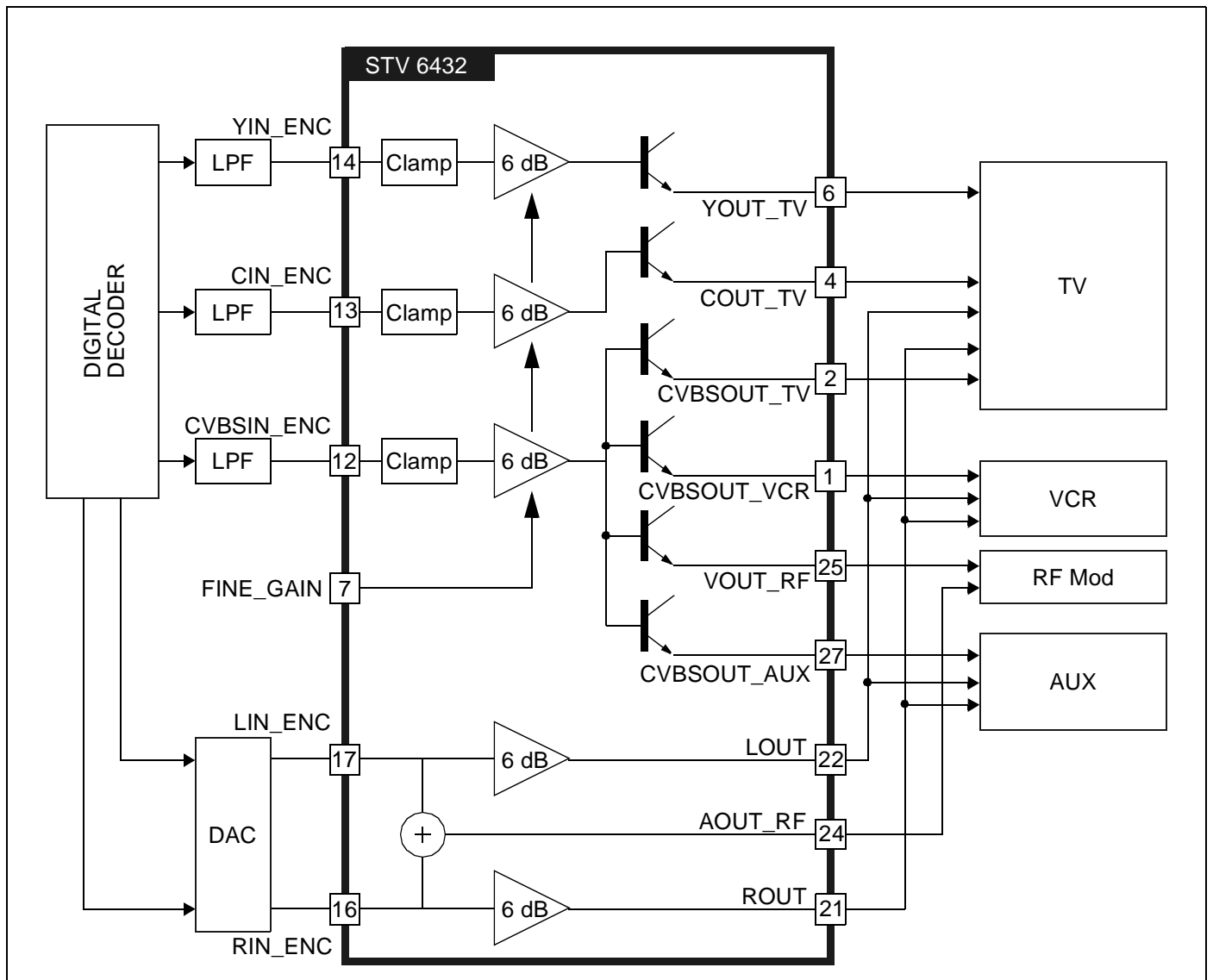

Table 1: Pin List Description

Pin No.	Symbol	Description
1	CVBSOUT_VCR	CVBS Output to VCR
2	CVBSOUT_TV	CVBS Output to TV
3	V _{CCB2}	+5 V Video Output Buffers Supply
4	COUT_TV	Chroma Output to TV
5	V _{CCB3}	+5 V Video Output Buffers Supply
6	YOUT_TV	Y Output to TV
7	FINE_GAIN	Y/C/CVBS Output Gain Fine Adjustment
8	NC	
9	GND	Ground
10	V _{CCV}	+5 V Video Supply
11	DECV	Video Decoupling Capacitor
12	CVBSIN_ENC	CVBS Input from Encoder
13	CIN_ENC	Chroma Input from Encoder
14	YIN_ENC	Y Input from Encoder
15	GND	Ground
16	RIN_ENC	Audio Right Input from Encoder
17	LIN_ENC	Audio Left Input from Encoder
18	DECA	Audio Decoupling Capacitor
19	GNDA	Audio Ground
20	V _{CCA}	+9 V Audio Supply or Audio Supply Decoupling
21	ROUT	Audio Right Output
22	LOUT	Audio Left Output
23	V _{CC12}	Audio Supply (+12V or +9V)
24	AOUT_RF	Audio (L+R) Output to RF Modulator
25	VOUT_RF	CVBS Video Output to RF Modulator
26	V _{CCB1}	+5 V Video Output Buffers Supply
27	CVBSOUT_AUX	CVBS Output to Auxiliary
28	GNDB	Video Buffer Ground

Figure 2: STV6432 Block Diagram



2 ELECTRICAL CHARACTERISTICS

2.1 Absolute Maximum Ratings

Table 2: Absolute Maximum Ratings

Symbol	Parameter	Value	Unit
V_{CC12}	Audio Section	13	V
V_{CCA}	Audio Section	10	V
V_{CCV} , V_{CCB}	Video Sections	6	V
V_I	Voltage at Pin 1 to GND - Audio pins - Video pins	0, V_{CCA} or V_{CC12} 0, V_{CCV} or V_{CCB}	V
V_{ESD}	Maximum ESD voltage allowed. 100 pF capacitor discharged through 1.5 k Ω serial resistor (Human Body Model)	± 4	kV
T_{oper}	Operating Ambient Temperature	0, +70	$^{\circ}\text{C}$
T_{stg}	Storage Temperature	0, +150	$^{\circ}\text{C}$

2.2 Thermal Data

Table 3: Thermal Data

Symbol	Parameter	Value	Unit
$R_{th(j-a)}$	Junction-ambient Thermal Resistance	71 (Max.)	$^{\circ}\text{C}/\text{W}$

2.3 Supply Section

$$T_{AMB} = 25^{\circ}\text{C}, V_{CCV} = 5\text{V}, V_{CCB} = 5\text{V}, V_{CCA} = 9\text{V}$$

$$R_{GA} = 600\ \Omega, R_{LOUTA} = 10\ \text{k}\Omega, R_{GV} = 75\ \Omega, R_{LOUTV} = 150\ \Omega, \text{ unless otherwise specified.}$$

Table 4: Supply Data

Symbol	Parameter	Test Conditions	Min.	Typ.	Max.	Unit
V_{CC12}	Audio Operating Supply Voltage	Decoupling capacitor on V_{CCA}	11.5	12	12.5	V
V_{CC12}	Audio Operating Supply Voltage	V_{CC12} connected to V_{CCA}	8.5	9	9.5	V
V_{CCA}	Audio Operating Supply Voltage		8.5	9	9.5	V
V_{CCV}	Video Operating Supply Voltage		4.5	5	5.5	V
V_{CCB}	Video Buffers Supply Voltage		4.5	5	5.5	V
I_{CC12}	Audio Output Supply Current	$V_{CC12} = 12\text{V}$, No load		5		mA
I_{CCA}	Audio Output Supply Current	$V_{CCA} = 9\text{V}$, No load		4		mA
I_{CCV}	Video Supply Current (V_{CCV})	$V_{CCV} = 5\text{V}$, No load		12		mA
I_{CCB}	Video Buffers Supply Current (V_{CCB})	$V_{CCB} = 5\text{V}$, No load		20		mA

2.4 Audio Section

$T_{AMB} = 25^{\circ} C$, $V_{CCV} = 5 V$, $V_{CCB} = 5 V$, $V_{CCA} = 9 V$

$R_{GA} = 600 \Omega$, $R_{LOUTA} = 10 k\Omega$, $R_{GV} = 75 \Omega$, $R_{LOUTV} = 150 \Omega$, unless otherwise specified.

Table 5: Audio Data

Symbol	Parameter	Test Conditions	Min.	Typ.	Max.	Unit
SVR100	Supply Voltage Rejection	$V_{RIPPLE} = 500 mV_{RMS}$ at 120 Hz, DECA filter cap = 47 μF DECA filter cap = 220 μF	60	70 80		dB
SVR1K	Supply Voltage Rejection	$V_{RIPPLE} = 500 mV_{RMS}$ at 1 kHz DECA filter cap = 220 μF	70	80		dB
V_{INDC}	Input DC Level	$V_{CCA} = 9 V$		$V_{CCA}/2$		V
V_{INAC}	Input Signal Amplitude				2	V_{RMS}
R_{IN}	Input Resistance		30	50		$k\Omega$
$R_{INmatch}$	Input Resistance Matching			± 2	± 10	%
F_{RANGE}	Bandwidth	-3 dB, $V_{IN} = 0.5 V_{RMS}$ $R_{LOAD} = 10 k\Omega$	50			kHz
Flatness	Spread of Gain in Audio Band (Peak-to-Peak)	$V_{IN} = 0.5 V_{RMS}$ 20 Hz to 20 kHz			± 0.5	dB
CS	Channel Separation between L & R TV outputs	$V_{IN} = 0.5 V_{RMS}$ at 1 kHz on one input, $R_{LOAD} = 10 k\Omega$ on both outputs	80	90		dB
Ci	Channel Isolation from video inputs	$V_{IN} = 1 V_{PP}$ at 15 kHz on one video input		85		dB
V_{OUT}	Output DC Level	$V_{CCA} = 9 V$		$V_{CCA}/2$		V
R_{OUT}	Output Resistance			60	120	Ω
PHD	Phase Difference	$V_{IN} = 1 V_{RMS}$ at 1 kHz on each input channel			3	Degree
ASN	Audio Signal/Noise ratio	$V_{IN} = 1 V_{RMS}$ A weighted at 1 kHz, Gain = 6 dB	80			dB
eNI ¹	Equivalent RMS Input Voltage Noise	BW = 20 Hz at 20 kHz unweighted, Gain = 6 dB		5		μV
GAL	6 dB Gain	$V_{IN} = 0.5 V_{RMS}$, $R_{LOAD} = 10 k\Omega$	5.5	6	+6.5	dB
G_{MA}	Gain matching between Left/Right outputs	$V_{IN} = 0.5 V_{RMS}$ at 1 kHz Gain = 6 dB	-1		1	dB
THD	Total Harmonic Distortion ENC Input with Gain = 6 dB	$V_{IN} = 0.5 V_{RMS}$ at 1 kHz Low Pass Filter at 80 kHz		0.005	0.05	%
V_{CL}	Output Clipping Level	THD = 0.2% at 1 kHz,	2.1	2.3		V_{RMS}
R_L	Output Load Resistance	$V_{IN} = 1 V_{RMS}$, THD = 0.3%,	2	2.25		$k\Omega$

1. eNI is the total unweighted output noise in a 20 Hz to 20 kHz bandwidth divided by the gain.

2.5 Video Section

$T_{AMB} = 25^{\circ} C$, $V_{CCV} = 5 V$, $V_{CCB} = 5 V$, $V_{CCA} = 9 V$

$R_{GA} = 600 \Omega$, $R_{LOUTA} = 10 k\Omega$, $R_{GV} = 75 \Omega$, $R_{LOUTV} = 150 \Omega$, unless otherwise specified.

Table 6: Video Data

Symbol	Parameter	Test Conditions	Min.	Typ.	Max.	Unit
V_{DCIN}	DC Input Level	Bottom Sync Pulse		2		V
I_{CLAMP}	Clamping Current	$V_{IN} = V_{DCIN} - 400 mV$	1	2		mA
I_{LEAK}	Input Leakage Current	$V_{IN} = V_{DCIN} + 1 V$		1	10	μA
C_{IN}	Input Capacitance			2		pF
V_{IN}	Maximum Input Signal	$V_{CCV} = 5 V$, Gain = 6 dB		1.5		V_{PP}
DYN	Dynamic Output Signal	$V_{CCV} = 5 V$, Gain = 6 dB		3		V_{PP}
BW	Bandwidth on Y and CVBS Outputs	$V_{IN} = 1 V_{PP}$, at -3 dB, Gain = 6 dB	8	15		MHz
Flatness	Spread of Gain in Video Band (15 kHz to 5 MHz) of Y and CVBS	$V_{IN} = 1 V_{PP}$			± 0.5	dB
VCT_O	Video Crosstalk Output Crosstalk Isolation between Output Channels	$V_{IN} = 1 V_{PP}$ at 3.58 MHz on either Y_{IN_ENC} or CIN_ENC inputs $R_{LOAD} = 150 \Omega$; Gain = 6dB		50		dB
VCT_{O1}	Video Crosstalk Output Crosstalk Isolation between Output Channels when CVBSIN_ENC is driven	$V_{IN} = 1 V_{PP}$ at 3.58 MHz on CVBSIN_ENC input; Only one CVBS output loaded at 150 Ω ; Gain = 6 dB		50		dB
VCT_{O4}	Video Crosstalk Output Crosstalk Isolation between Output Channels when CVBSIN_ENC is driven	$V_{IN} = 1 V_{PP}$ at 3.58 MHz on CVBSIN_ENC input; All 4 CVBS outputs loaded at 150 Ω ; Gain = 6 dB		44		dB
R_{OUT}	Output Resistance			5	10	Ω
G_{V5}	5 dB Gain on Y and CVBS Channels	$V_{IN} = 1 V_{PP}$ Pin 7 to GND or Logic "0"	4.5	5	5.5	dB
G_{V6}	6 dB Gain on Y and CVBS Channels	$V_{IN} = 1 V_{PP}$. Pin 7 is open ¹	5.5	6	6.5	dB
G_{V7}	7 dB Gain on Y and CVBS Channels	$V_{IN} = 1 V_{PP}$; Pin 7 connected to V_{CCV} (5 V) via 22 k Ω or to 3.3 V	6.5	7	7.5	dB
G_{V8}	8 dB Gain on Y and CVBS Channels	$V_{IN} = 1 V_{PP}$ Pin 7 to V_{CCV} (5 V)	7.5	8	8.5	dB
VH5	5 dB Gain: Max. V_{IN} Voltage on Pin 7	Pin 7 to Ground or Logic "0" ($I_{IN} < 160 \mu A$)			1.1	V
VL6	6 dB Gain: Min. V_{IN} Voltage on Pin 7	Pin 7 is open.	1.3			V
VH6	6 dB Gain: Max. V_{IN} Voltage on Pin 7	Pin 7 is open.			1.7	V
VL7	7 dB Gain: Min. V_{IN} Voltage on Pin 7	Pin 7 connected to V_{CCV} (5 V) via 22 k Ω or to 3.3 V ($I_{IN} < 140 \mu A$)	1.9			V
VH7	7 dB Gain: Max. V_{IN} Voltage on Pin 7	Pin 7 connected to V_{CCV} (5 V) via 22 k Ω or to 3.3 V ($I_{IN} < 140 \mu A$)			4.0	V
VL8	8 dB Gain: Min. V_{IN} Voltage on Pin 7	Pin 7 connected to V_{CCV} (5 V) ($I_{IN} < 350 \mu A$)	4.2			V
DC_{OUT}	DC Output Voltage	Bottom sync pulse		0.6		V
DPHI	Differential Phase	$V_{IN} = 1 V_{PP}$ at 3.58 MHz		1	5	Degree
DG	Differential Gain	$V_{IN} = 1 V_{PP}$ at 3.58 MHz		1	5	%
LNL	Luminance Non-Linearity			0.3	3	%
VSN	Video S/N Ratio ²		65			dB

1. When Pin 7 is left open, its voltage is determined by an internal voltage divider consisting of 42 k Ω to V_{CC} (5 V) and 18 k Ω to Ground

2. $S/N = 20 \log (V_{OUT} \text{ Black to White} = 0.7 V_{PP} / V_{Noise} (mV_{RMS}) \text{ weighted CCIR 567})$.

2.6 Chroma Section

$T_{AMB} = 25^{\circ} C$, $V_{CCV} = 5 V$, $V_{CCB} = 5 V$, $V_{CCA} = 9 V$

$R_{GA} = 600 \Omega$, $R_{LOUTA} = 10 k\Omega$, $R_{GV} = 75 \Omega$, $R_{LOUTV} = 150 \Omega$, unless otherwise specified.

Table 7: Supply Data

Symbol	Parameter	Test Conditions	Min.	Typ.	Max.	Unit
V_{DCIN}	DC Input Level			3		V
R_{IN}	Input Resistance		30	50		k Ω
C_{IN}	Input Capacitance			2		pF
V_{IN}	Max Input Signal	Gain = 6 dB		1.5		V_{PP}
DYN	Dynamic Output Signal	Gain = 6 dB		3		V_{PP}
DC _{OUT}	DC Output Voltage			2.2		V
CBW	Chroma Bandwidth	$V_{IN} = 1 V_{PP}$ at -3 dB Gain = 6 dB	8			MHz
CCT _O	Chroma Crosstalk Output Crosstalk Isolation between Output Channels	$V_{IN} = 1 V_{PP}$ at 3.58 MHz on input YIN_ENC $R_{LOAD} = 150 \Omega$, Gain = 6 dB		50		dB
CCT _{O1}	Chroma Crosstalk Output Crosstalk Isolation between Output Channels when CVBSIN_ENC is driven	$V_{IN} = 1 V_{PP}$ at 3.58 MHz on CVBSIN_ENC input; Only one CVBS output loaded at 150 Ω ; Gain = 6 dB		50		dB
CCT _{O4}	Chroma Crosstalk Output Crosstalk Isolation between Output Channels when CVBSIN_ENC is driven	$V_{IN} = 1 V_{PP}$ at 3.58 MHz on CVBSIN_ENC input; All 4 CVBS outputs loaded at 150 Ω ; Gain = 6 dB		44		dB
R _{OUT}	Output Resistance			5	10	Ω
G _{C5}	5 dB Gain on Chroma Channels	$V_{IN} = 1 V_{PP}$ Pin 7 to GND or Logic "0"	4.5	5	5.5	dB
G _{C6}	6 dB Gain on Chroma Channels	$V_{IN} = 1 V_{PP}$, Pin 7 is open ¹	5.5	6	6.5	dB
G _{C7}	7 dB Gain on Chroma Channels	$V_{IN} = 1 V_{PP}$; Pin 7 connected to V_{CCV} (5 V) via 22 k Ω or to 3.3 V	6.5	7	7.5	dB
G _{C8}	8 dB Gain on Chroma Channels	$V_{IN} = 1 V_{PP}$ Pin 7 to V_{CCV} (5 V)	7.5	8	8.5	dB
C _{ToYdel}	Chroma to Luma Delay, Source Y/C	$V_{IN} = 1 V_{PP}$ at 3.58 MHz			20	ns

1. When Pin 7 is left open, its voltage is determined by an internal voltage divider consisting of 42 k Ω to V_{CC} (5 V) and 18 k Ω to Ground

3 INPUT/OUTPUT GROUPS

Figure 3: Bottom Clamped Video Inputs (Pins 12 & 14)

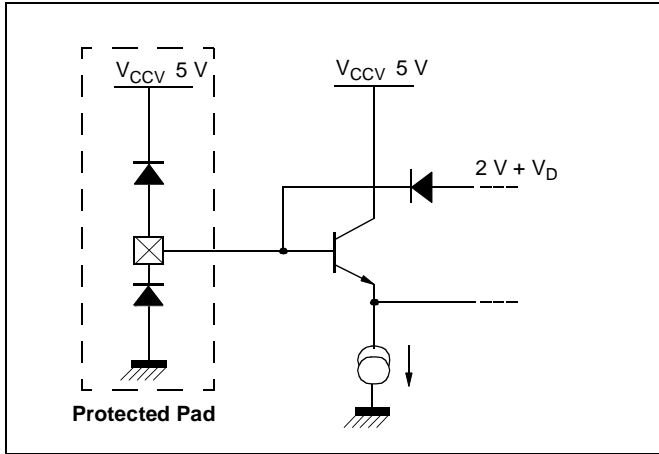

Figure 6: Audio Inputs (Pins 16 and 17)

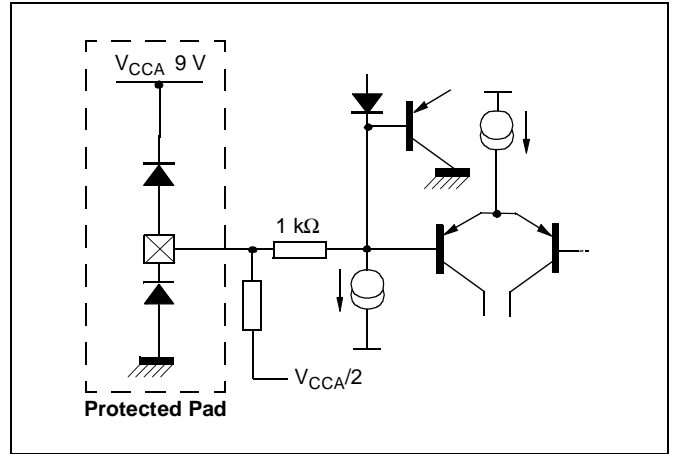

Figure 4: Average Clamped Video Inputs (Pin 13)

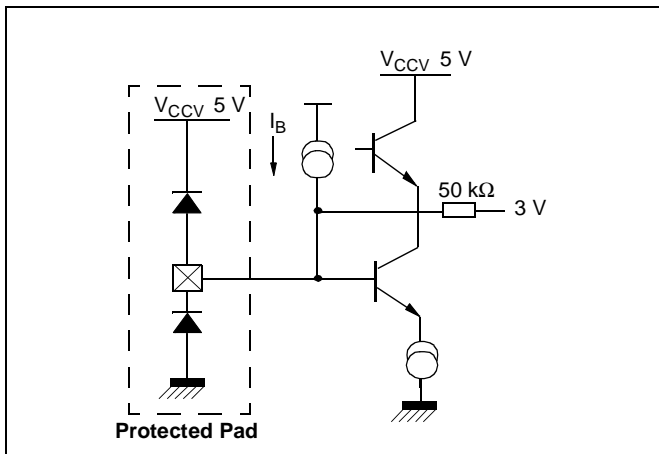

Figure 7: Audio Outputs (Pins 21, 22 and 24)

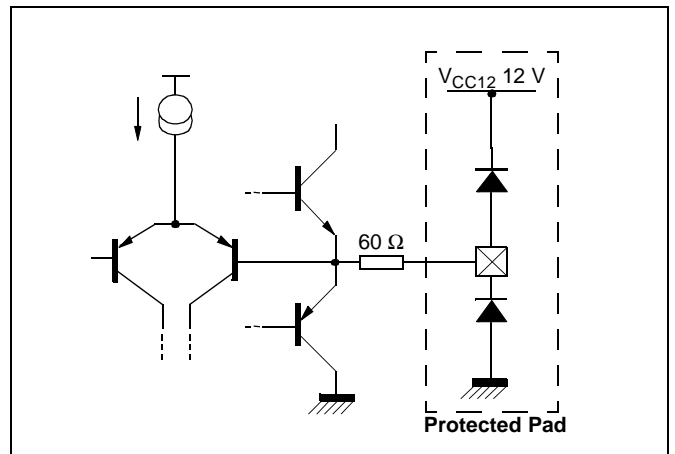

Figure 5: Video Outputs (Pins 1, 2, 4, 6, 25 and 27)

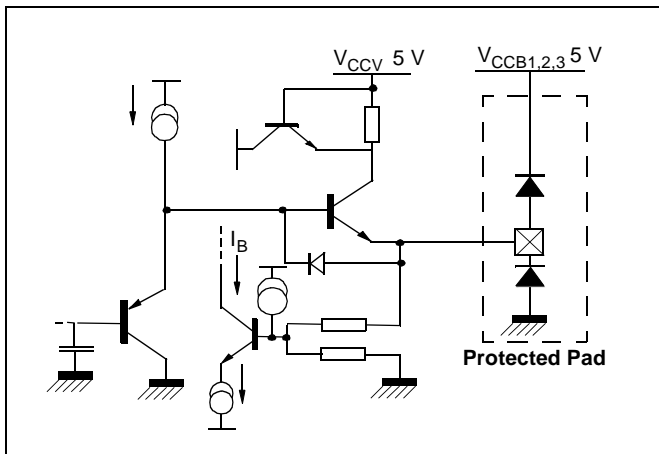

Figure 8: Fine Gain Control Input (Pin 7)

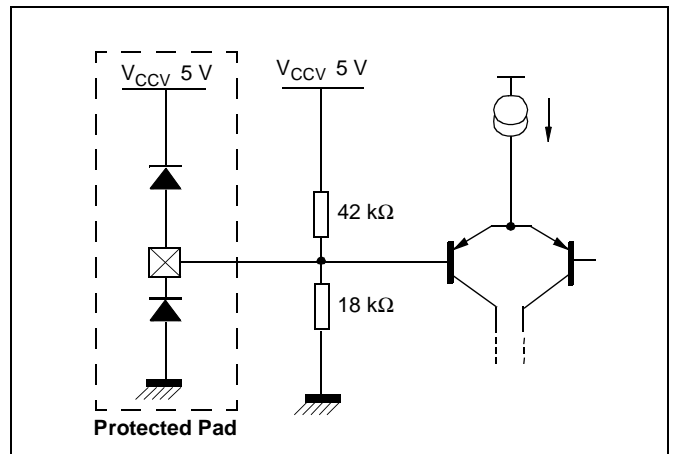

Figure 9: Video Decoupling (Pin 11)

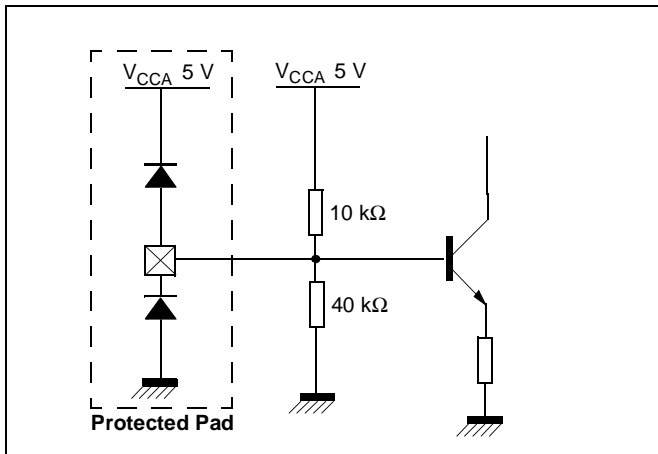

Figure 10: Audio Decoupling (Pin 18)

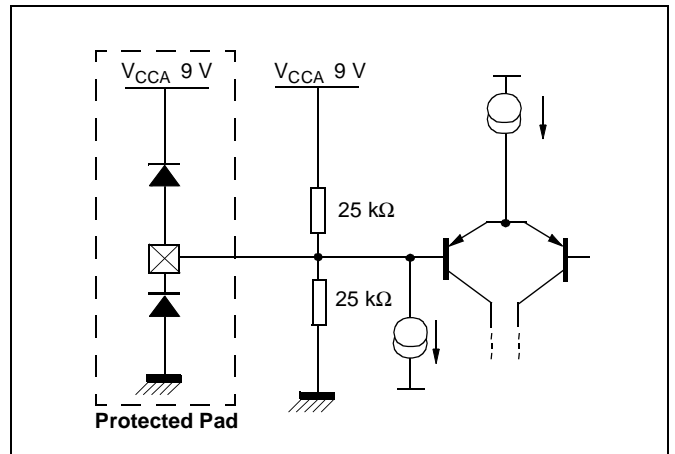
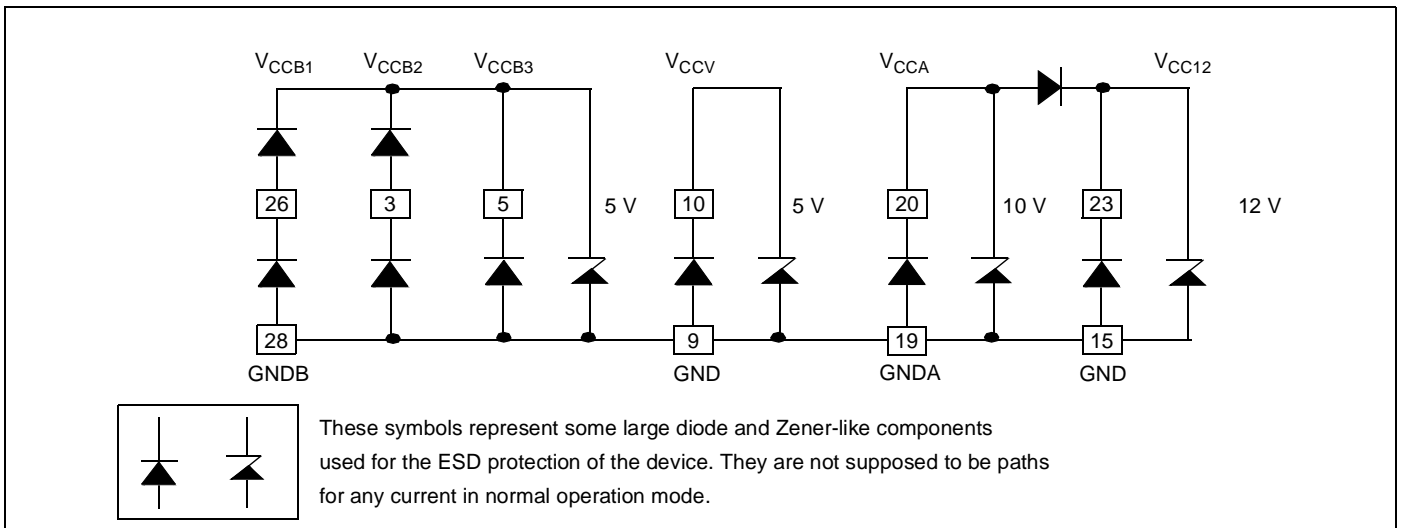
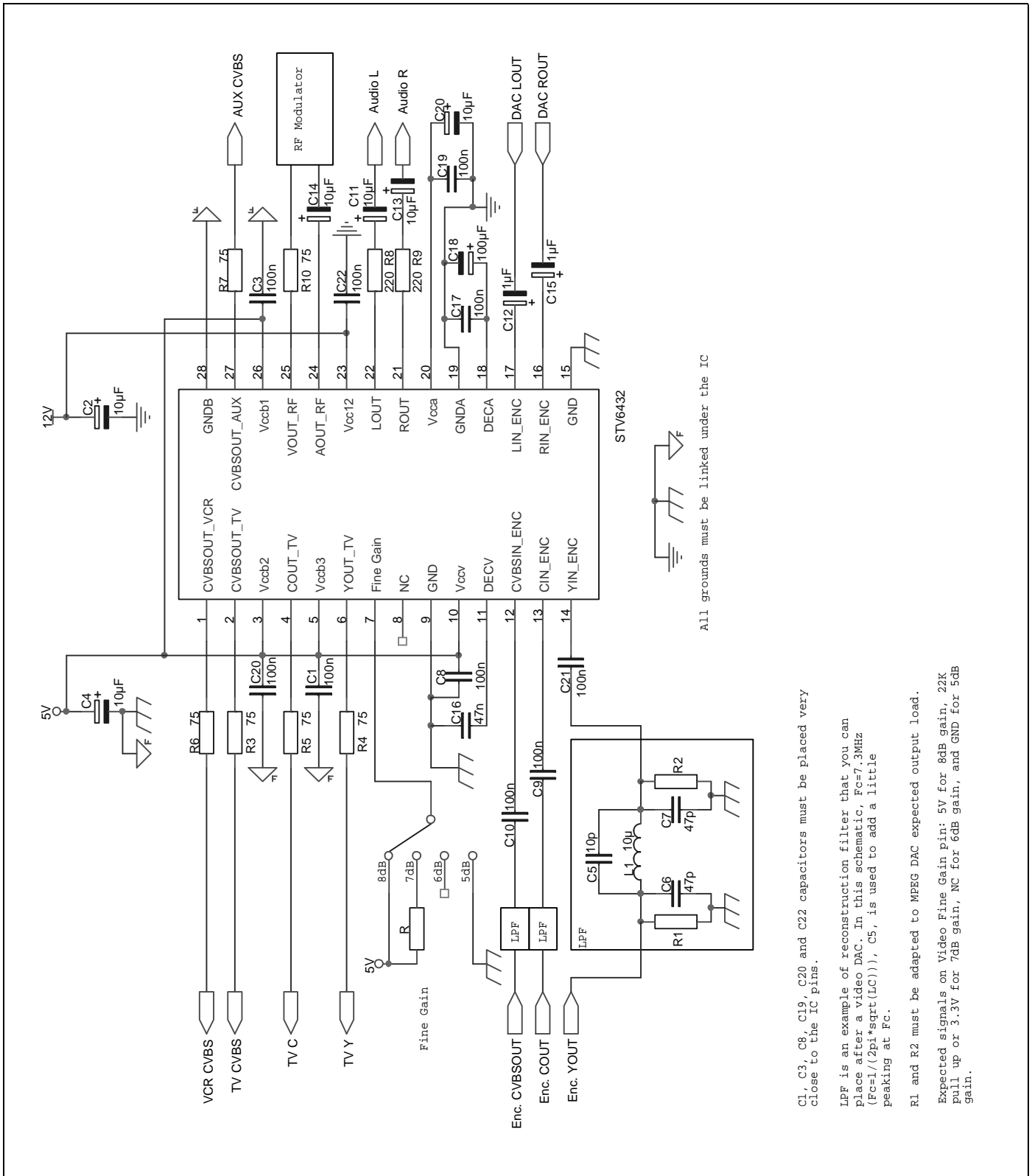

Figure 11: Power Supply Connections



4 APPLICATION DIAGRAMS

Figure 12: Application Diagram for 5V/12V Power Supplies



C1, C3, C8, C19, C20 and C22 capacitors must be placed very close to the IC pins.

LPF is an example of reconstruction filter that you can place after a video DAC. In this schematic, $f_c = 7.3\text{MHz}$ ($f_c = 1 / (2\pi \cdot \sqrt{LC})$), C5, is used to add a little peaking at f_c .

R1 and R2 must be adapted to MPEG DAC expected output load.

Expected signals on Video Fine Gain pin: 5V for 8dB gain, 22K pull up or 3.3V for 7dB gain, NC for 6dB gain, and GND for 5dB gain.

Figure 13: Application Diagram for 5V/9V Power Supplies

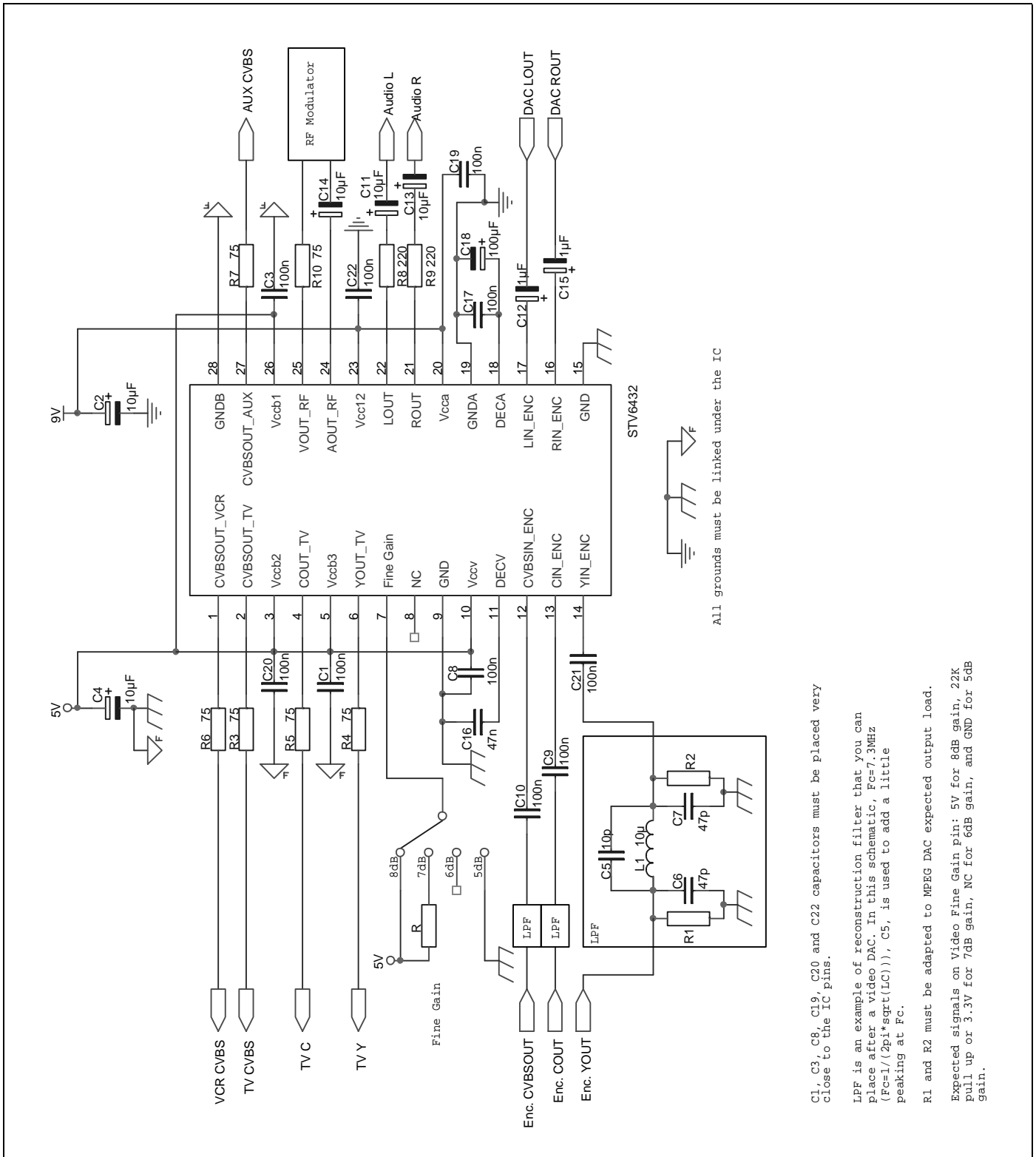

C1, C3, C8, C19, C20 and C22 capacitors must be placed very close to the IC pins.

LPF is an example of reconstruction filter that you can place after a video DAC. In this schematic, $F_c = 7.3\text{MHz}$ ($F_c = 1 / (2\pi \cdot \sqrt{L \cdot C})$), C5, is used to add a little peaking at F_c .

R1 and R2 must be adapted to MPEG DAC expected output load.

Expected signals on Video Fine Gain pin: 5V for 8dB gain, 22K Pull up or 3.3V for 7dB gain, NC for 6dB gain, and GND for 5dB gain.

5 PACKAGE MECHANICAL DATA

Figure 14: SO28 28-pin Plastic Small Outline Package (300-mil width)

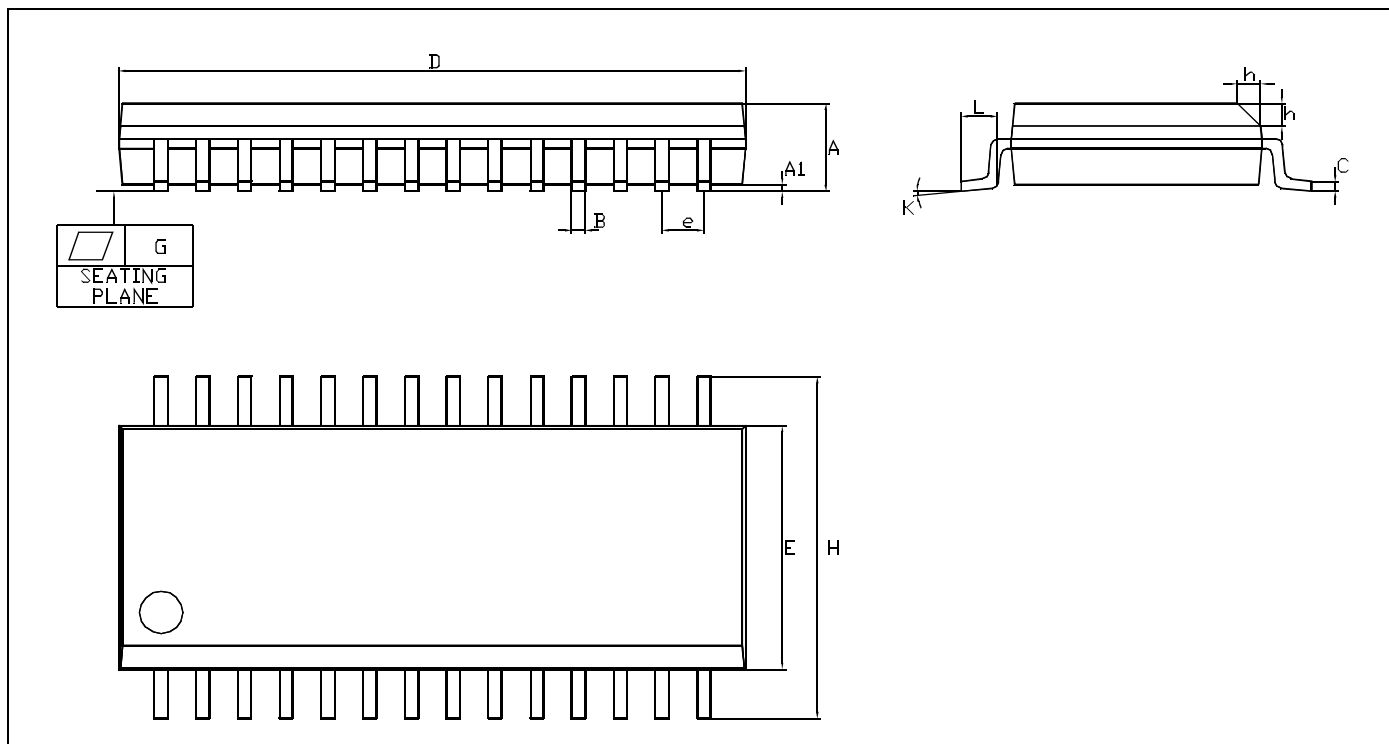

Table 8: SO28 Physical Characteristics

Dim.	mm			Inches		
	Min.	Typ.	Max.	Min.	Typ.	Max.
A	2.35		2.65	0.0926		0.1043
A1	0.10		0.30	0.0040		0.0118
B	0.33		0.51	0.013		0.020
C	0.23		0.32	0.0091		0.0125
D	17.70		18.10	0.6969		0.7125
E	7.40		7.60	0.2914		0.2992
e		1.27			0.0500	
H	10.01		10.64	0.394		0.419
h	0.25		0.74	0.010		0.029
K				0°		8°
L	0.41		1.27	0.016		0.050
G			0.10			0.004

6 REVISION HISTORY

Table 9: Summary of Modifications

Revision	Main Changes	Date
1.0	First Issue	March 2001
1.1	Addition of Section 4: APPLICATION DIAGRAMS on page 11 and Section 6: REVISION HISTORY on page 14.	26 April 2001
1.2	Reformat of Page Layout. Addition of Video and Audio Crosstalk Values (VCT _{O1} and CCT _{O1}). Modification of Application Diagrams.	29 June 2001

Information furnished is believed to be accurate and reliable. However, STMicroelectronics assumes no responsibility for the consequences of use of such information nor for any infringement of patents or other rights of third parties which may result from its use. No license is granted by implication or otherwise under any patent or patent rights of STMicroelectronics. Specifications mentioned in this publication are subject to change without notice. This publication supersedes and replaces all information previously supplied. STMicroelectronics products are not authorized for use as critical components in life support devices or systems without express written approval of STMicroelectronics.

The ST logo is a registered trademark of STMicroelectronics

© 2003STMicroelectronics - All Rights Reserved

STMicroelectronics GROUP OF COMPANIES

Australia - Brazil - Canada - China - Finland - France - Germany - Hong Kong - India - Israel - Italy - Japan
Malaysia - Malta - Morocco - Singapore - Spain - Sweden - Switzerland - United Kingdom - U.S.A.

www.st.com