

# DATA SHEET

**TDA3654**

**TDA3654Q**

Vertical deflection and guard circuit  
(110°)

Product specification  
File under Integrated Circuits, IC02

March 1991

## Vertical deflection and guard circuit (110°)

TDA3654  
TDA3654Q

### GENERAL DESCRIPTION

The TDA3654 is a full performance vertical deflection output circuit for direct drive of the deflection coils and can be used for a wide range of 90° and 110° deflection systems.

A guard circuit is provided which blanks the picture tube screen in the absence of deflection current.

### Features

- Direct drive to the deflection coils
- 90° and 110° deflection system
- Internal blanking guard circuit
- Internal voltage stabilizer

### QUICK REFERENCE DATA

Output voltage	$V_{5-2}$	max.	60	V
Output current (peak-to-peak)	$I_{5(p-p)}$	max.	3	A
Supply voltage	$V_{9-2}$	max.	40	V
Guard circuit output voltage	$V_{7-2}$	max.	5,6	V
Operating ambient temperature range	$T_{amb}$		-25 to +60	°C
Storage temperature	$T_{stg}$		-55 to +150	°C

### THERMAL RESISTANCE

From junction to mounting base	$R_{th\ j-mb}$	3,5 to 4	K/W
--------------------------------	----------------	----------	-----

### PACKAGE OUTLINES

TDA3654 : 9-lead SIL; plastic power (SOT131) <sup>(1)</sup>.

TDA3654Q : 9-lead SIL bent to DIL; plastic power (SOT157) <sup>(2)</sup>.

### Notes

1. SOT131-2; 1997 January 07
2. SOT157-2; 1997 January 07

Vertical deflection and guard circuit (110°)

TDA3654  
TDA3654Q

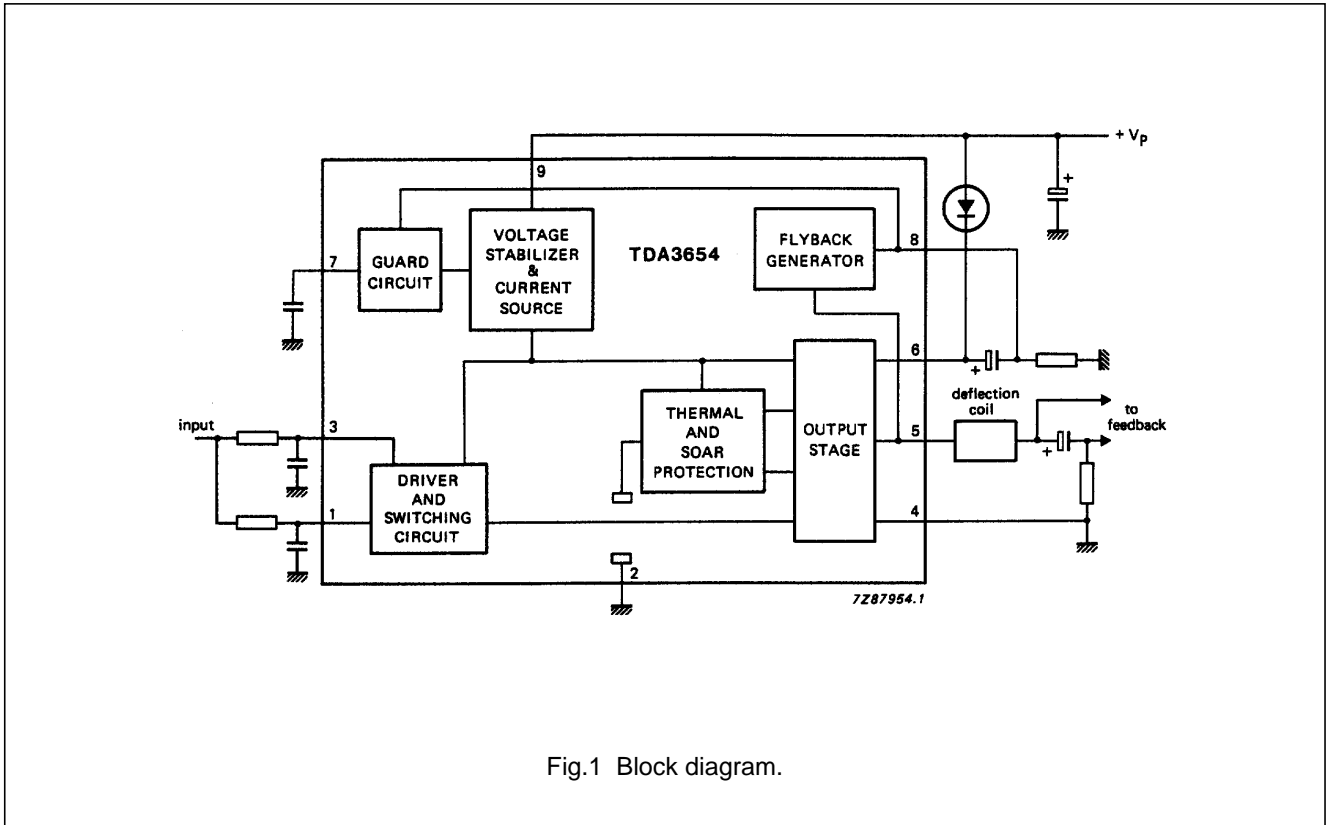

Fig.1 Block diagram.

---

## Vertical deflection and guard circuit (110°)

---

TDA3654  
TDA3654Q

### FUNCTIONAL DESCRIPTION

#### Output stage and protection circuits

The output stage consists of two Darlington configurations in class B arrangement.

Each output transistor can deliver 1,5 A maximum and the  $V_{CE0}$  is 60 V.

Protection of the output stage is such that the operation of the transistors remains well within the SOAR area in all circumstances at the output pin, (pin 5). This is obtained by the cooperation of the thermal protection circuit, the current-voltage detector and the short circuit protection.

Special measures in the internal circuit layout give the output transistors extra solidity, this is illustrated in Fig.5 where typical SOAR curves of the lower output transistor are given. The same curves also apply for the upper output device. The supply for the output stage is fed to pin 6 and the output stage ground is connected to pin 4.

#### Driver and switching circuit

Pin 1 is the input for the driver of the output stage. The signal at pin 1 is also applied to pin 3 which is the input of a switching circuit (pin 1 and 3 are connected via external resistors).

This switching circuit rapidly turns off the lower output stage when the flyback starts and it, therefore, allows a quick start of the flyback generator. The maximum required input signal for the maximum output current peak-to-peak value of 3 A is only 3 V, the sum of the currents in pins 1 and 3 is then maximum 1 mA.

#### Flyback generator

During scan, the capacitor between pins 6 and 8 is charged to a level which is dependent on the value of the resistor at pin 8 (see Fig.1).

When the flyback starts and the voltage at the output pin (pin 5) exceeds the supply voltage, the flyback generator is activated.

The supply voltage is then connected in series, via pin 8, with the voltage across the capacitor during the flyback period. This implies that during scan the supply voltage can be reduced to the required scan voltage plus saturation voltage of the output transistors.

The amplitude of the flyback voltage can be chosen by changing the value of the external resistor at pin 8.

It should be noted that the application is chosen such that the lowest voltage at pin 8 is > 1,5 V, during normal operation.

#### Guard circuit

When there is no deflection current, for any reason, the voltage at pin 8 becomes less than 1 V, the guard circuit will produce a d.c. voltage at pin 7. This voltage can be used to blank the picture tube, so that the screen will not burn in.

#### Voltage stabilizer

The internal voltage stabilizer provides a stabilized supply of 6 V to drive the output stage, so the drive current is not affected by supply voltage variations.

## Vertical deflection and guard circuit (110°)

TDA3654  
TDA3654Q**RATINGS**

Limiting values in accordance with the Absolute Maximum System (IEC 134).

Pins 2 and 4 are externally connected to ground.

**Voltages**

Output voltage	$V_{5-4}$	0 to 60	V
Supply voltage	$V_{9-4}$	0 to 40	V
Supply voltage output stage	$V_{6-4}$	0 to 60	V
Input voltage	$V_{1-2}$	0 to $V_{9-4}$	V
Input voltage switching circuit	$V_{3-2}$	0 to $V_{9-4}$	V
External voltage at pin 7	$V_{7-2}$	0 to 5,6	V

**Currents**

Repetitive peak output current	$\pm I_{5RM}$	max. 1,5	A
Non-repetitive peak output current (note 1)	$\pm I_{5SM}$	max. 3	A
Repetitive peak output current of flyback generator	$I_{8RM}$	max. + 1,5 - 1,6	A A
Non-repetitive peak output current of flyback generator (note 1)	$\pm I_{8SM}$	max. 3	A

**Temperatures**

Storage temperature range	$T_{stg}$	-65 to + 150	°C
Operating ambient temperature range (see Fig.3)	$T_{amb}$	-25 to + 60	°C
Operating junction temperature range (the output current at pin 5 should not exceed 2.5A)	$T_j$	-25 to + 150	°C

## Vertical deflection and guard circuit (110°)

TDA3654  
TDA3654Q**CHARACTERISTICS**T<sub>amb</sub> = 25 °C, supply voltage (V<sub>9-4</sub>) = 26 V; unless otherwise stated; pin 1 externally connected to pin 3.

Pins 2 and 4 externally connected to ground.

PARAMETER	SYMBOL	MIN.	TYP.	MAX.	UNIT
<b>Supply</b>					
Supply voltage, pin 9 (note 2)	V <sub>9-4</sub>	10	–	40	V
Supply voltage output stage	V <sub>6-4</sub>	–	–	60	V
Supply current, pins 6 and 9 (note 3)	I <sub>6</sub> +I <sub>9</sub>	35	55	85	mA
Quiescent current (note 4)	I <sub>4</sub>	25	40	65	mA
Variation of quiescent current with temperature	TC	–	–0,04	–	mA/K
<b>Output current</b>					
Output current, pin 5 (peak-to-peak)	I <sub>5(p-p)</sub>	–	2,5	3	A
Output current flyback generator, pin 8	+ I <sub>8(p-p)</sub> – I <sub>8(p-p)</sub>	–	1,25 1,35	1,5 1,6	A A
<b>Output voltage</b>					
Peak voltage during flyback	V <sub>5-4</sub>	–	–	60	V
Saturation voltage to supply at I <sub>5</sub> = –1,5 A	V <sub>6-5(sat)</sub>		2,5	3,2	V
at I <sub>5</sub> = 1,5 A (note 5)	V <sub>5-6(sat)</sub>		2,5	3,2	V
at I <sub>5</sub> = –1,2 A	V <sub>6-5(sat)</sub>		2,2	2,7	V
at I <sub>5</sub> = 1,2 A (note 5)	V <sub>5-6(sat)</sub>		2,3	2,8	V
Saturation voltage to ground at I <sub>5</sub> = 1,2 A	V <sub>5-4(sat)</sub>	–	2,2	2,7	V
at I <sub>5</sub> = 1,5 A	V <sub>5-4(sat)</sub>	–	2,5	3,2	V
<b>Flyback generator</b>					
Saturation voltage at I <sub>8</sub> = –1,6 A	V <sub>9-8(sat)</sub>	–	1,6	2,1	V
at I <sub>8</sub> = 1,5 A (note 5)	V <sub>8-9(sat)</sub>	–	2,3	3	V
at I <sub>8</sub> = –1,3 A	V <sub>9-8(sat)</sub>	–	1,4	1,9	V
at I <sub>8</sub> = 1,2 A (note 5)	V <sub>8-9(sat)</sub>	–	2,2	2,7	V
Leakage current at pin 8	–I <sub>8</sub>	–	5	100	μA
Flyback generator active if:	V <sub>5-9</sub>	4	–	–	V
<b>Input</b>					
Input current, pin 1, for I <sub>5</sub> = 1,5 A	I <sub>1</sub>	–	0,33	0,55	mA
Input voltage during scan, pin 1	V <sub>1-2</sub>	–	2,35	3	V

## Vertical deflection and guard circuit (110°)

TDA3654  
TDA3654Q

PARAMETER	SYMBOL	MIN.	TYP.	MAX.	UNIT
Input current, pin 3, during scan (note 6)	$I_3$	0,03	–	–	mA
Input voltage, pin 3, during scan (note 6)	$V_{3-2}$	0,8	–	$V_{9-4}$	V
Input voltage, pin 1, during flyback	$V_{1-2}$	–	–	250	mV
Input voltage, pin 3, during flyback	$V_{3-2}$	–	–	250	mV
<b>Guard circuit</b>					
Output voltage, pin 7 $R_L = 100 \text{ k}\Omega$ (note 9)	$V_{7-2}$	4,1	4,5	5,8	V
Output voltage, pin 7 at $I_L = 0,5 \text{ mA}$ (note 9)	$V_{7-2}$	3,4	3,9	5,3	V
Internal series resistance of pin 7	$R_{i7}$	0,95	1,35	1,7	k $\Omega$
Guard circuit activates (note 7)	$V_{8-2}$	–	–	1,0	V
<b>General data</b>					
Thermal protection activation range	$T_j$	158	175	192	°C
<b>Thermal resistance</b>					
From junction to mounting base	$R_{th \text{ j-mb}}$	–	3,5	4	K/W
Power dissipation	$P_{tot}$	–	see Fig.3		
Open loop gain at 1 kHz; (note 8)	$G_o$	–	33	–	
Frequency response, –3 dB; (note 10)	f	–	60	–	kHz

**Notes**

1. Non-repetitive duty factor 3,3%.
2. The maximum supply voltage should be chosen so that during flyback the voltage at pin 5 does not exceed 60 V.
3. When  $V_{5-4}$  is 13 V and no load at pin 5.
4. See Fig.4.
5. Duty cycle,  $d = 5\%$  or  $d = 0,05$ .
6. When pin 3 is driven separately from pin 1.
7. During normal operation the voltage  $V_{8-2}$  may not be lower than 1,5 V.
8.  $R_L = 8 \Omega$ ;  $I_L = 125 \text{ mA}$  (r.m.s.).
9. If guard circuit is active.
10. With a 22 pF capacitor between pins 1 and 5.

Vertical deflection and guard circuit (110°)

TDA3654  
TDA3654Q

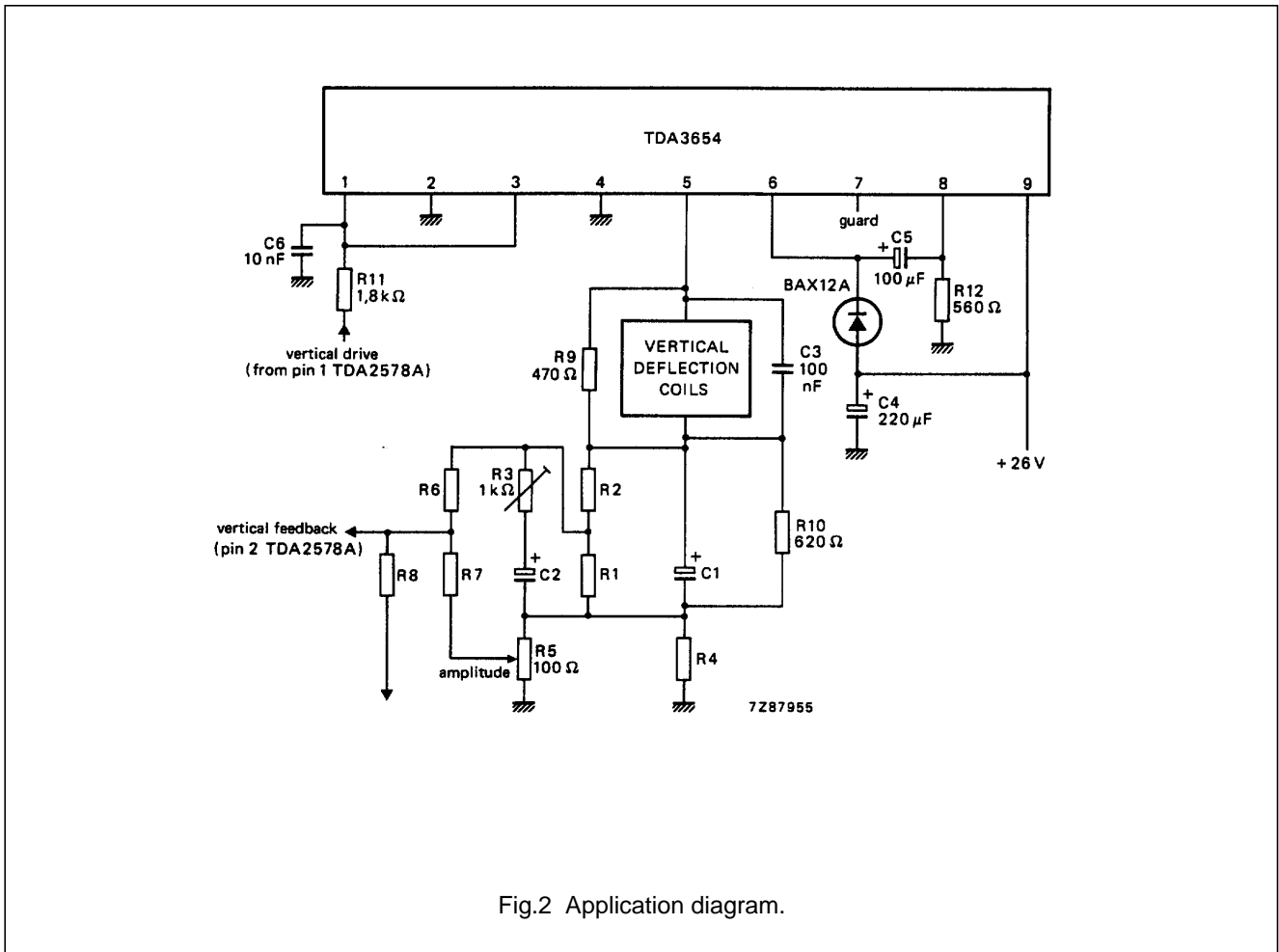

Fig.2 Application diagram.



Vertical deflection and guard circuit (110°)

TDA3654  
TDA3654Q

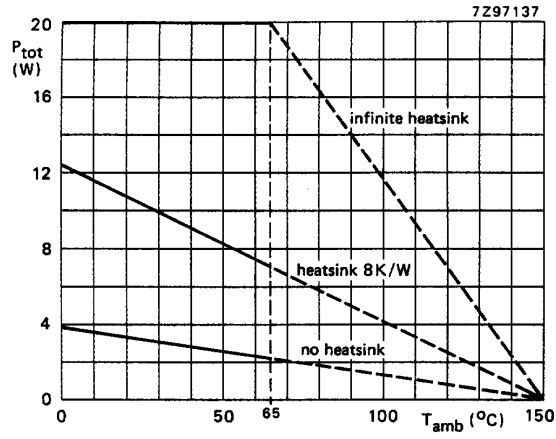

Fig.3 Power derating curve.

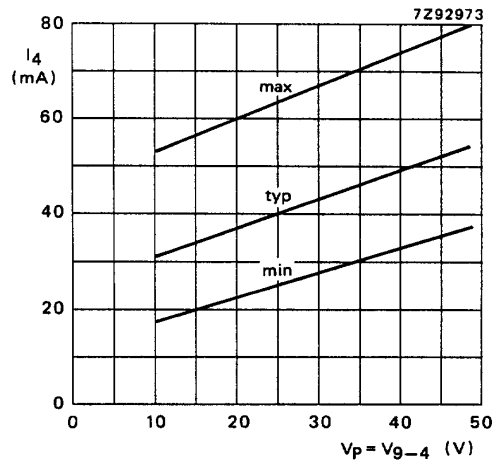

Fig.4 Quiescent current as a function of the supply voltage.

Vertical deflection and guard circuit (110°)

TDA3654  
TDA3654Q

curve	$t_p$	$\delta$	peak junction temperature
1	d.c.	—	150 °C
2	10 ms	0,5	150 °C
3	10 ms	0,25	150 °C
4	1 ms	0,5	150 °C
5	1 ms	0,25	150 °C
6	1 ms	0,05	150 °C
7	1 ms	0,05	180 °C
8	0,2 ms	0,1	150 °C
9	0,2 ms	0,1	180 °C

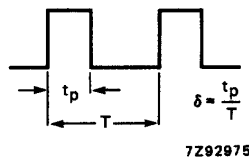
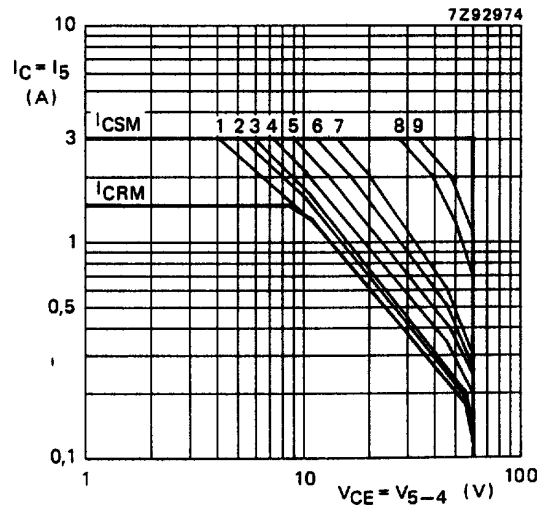

Fig.5 Typical SOAR of lower output transistor.

Vertical deflection and guard circuit (110°)

TDA3654  
TDA3654Q

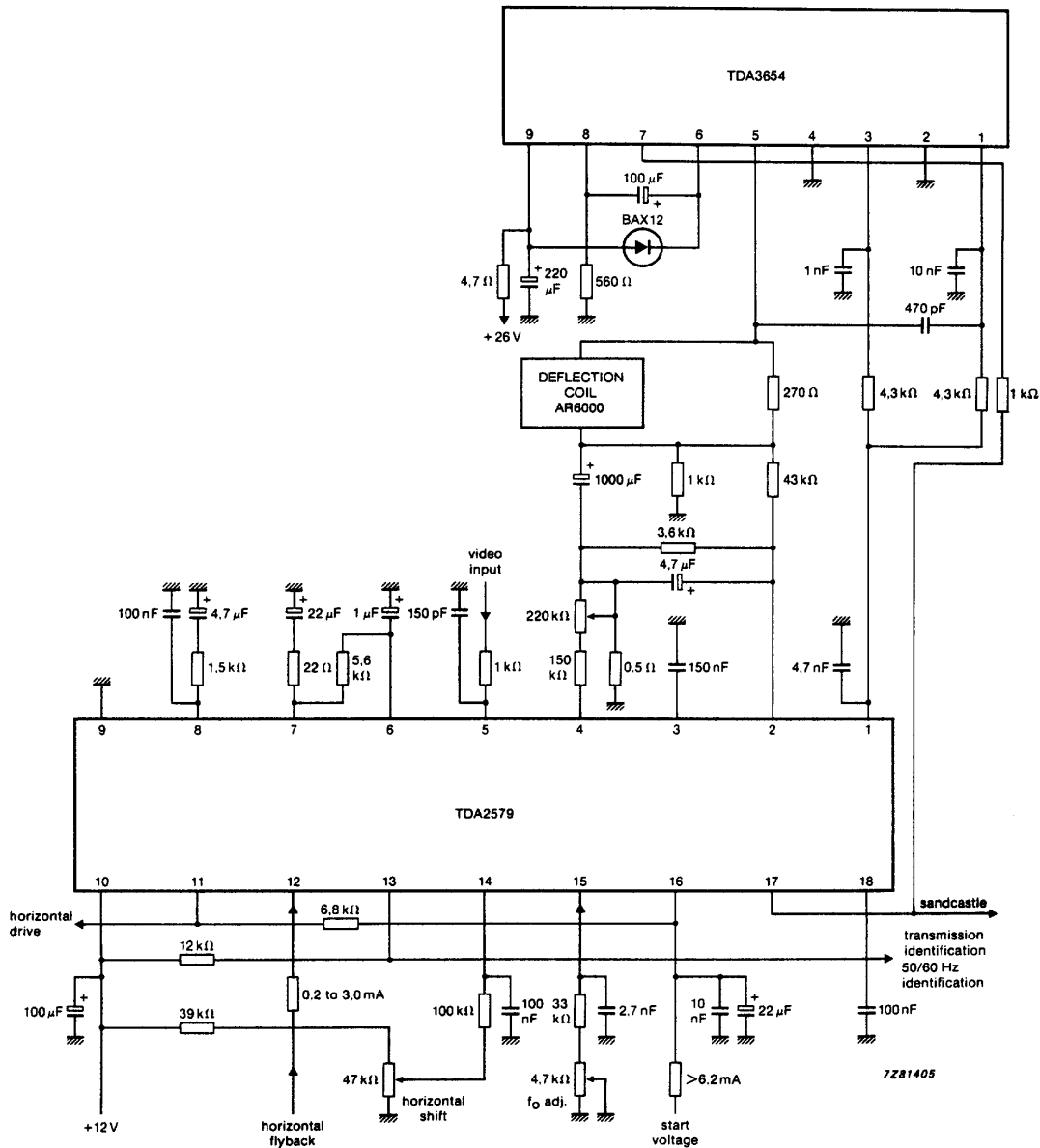

Fig.6 Application diagram in combination with TDA2579.

Vertical deflection and guard circuit (110°)

TDA3654  
TDA3654Q

PACKAGE OUTLINES

SIL9P: plastic single in-line power package; 9 leads

SOT131-2

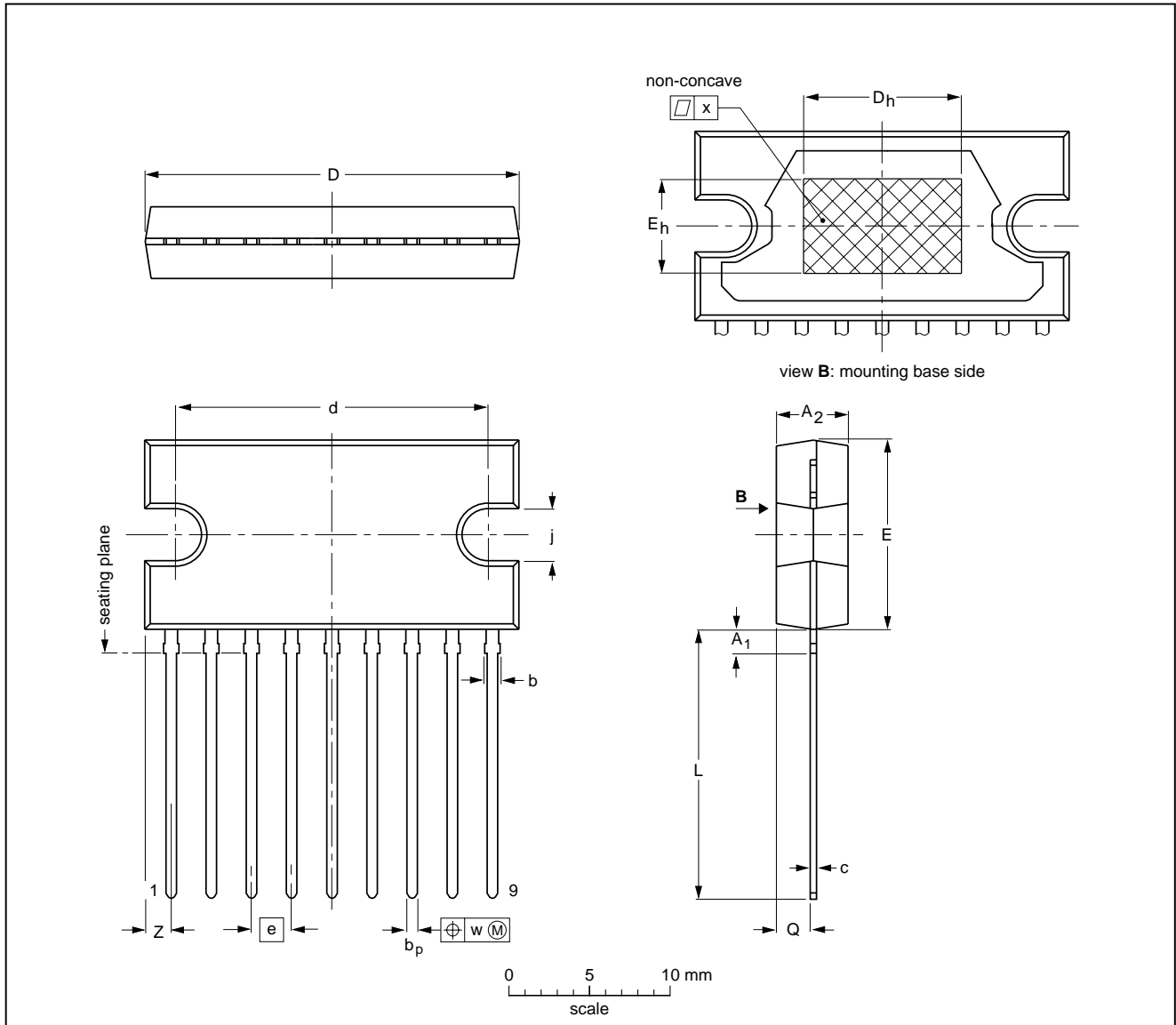

DIMENSIONS (mm are the original dimensions)

UNIT	A <sub>1</sub> max.	A <sub>2</sub>	b max.	b <sub>p</sub>	c	D <sup>(1)</sup>	d	D <sub>h</sub>	E <sup>(1)</sup>	e	E <sub>h</sub>	j	L	Q	w	x	Z <sup>(1)</sup>
mm	2.0	4.6 4.2	1.1	0.75 0.60	0.48 0.38	24.0 23.6	20.0 19.6	10	12.2 11.8	2.54	6	3.4 3.1	17.2 16.5	2.1 1.8	0.25	0.03	2.00 1.45

Note

1. Plastic or metal protrusions of 0.25 mm maximum per side are not included.

OUTLINE VERSION	REFERENCES				EUROPEAN PROJECTION	ISSUE DATE
	IEC	JEDEC	EIAJ			
SOT131-2						92-11-17 95-03-11

Vertical deflection and guard circuit (110°)

TDA3654  
TDA3654Q

DBS9P: plastic DIL-bent-SIL power package; 9 leads (lead length 12 mm)

SOT157-2

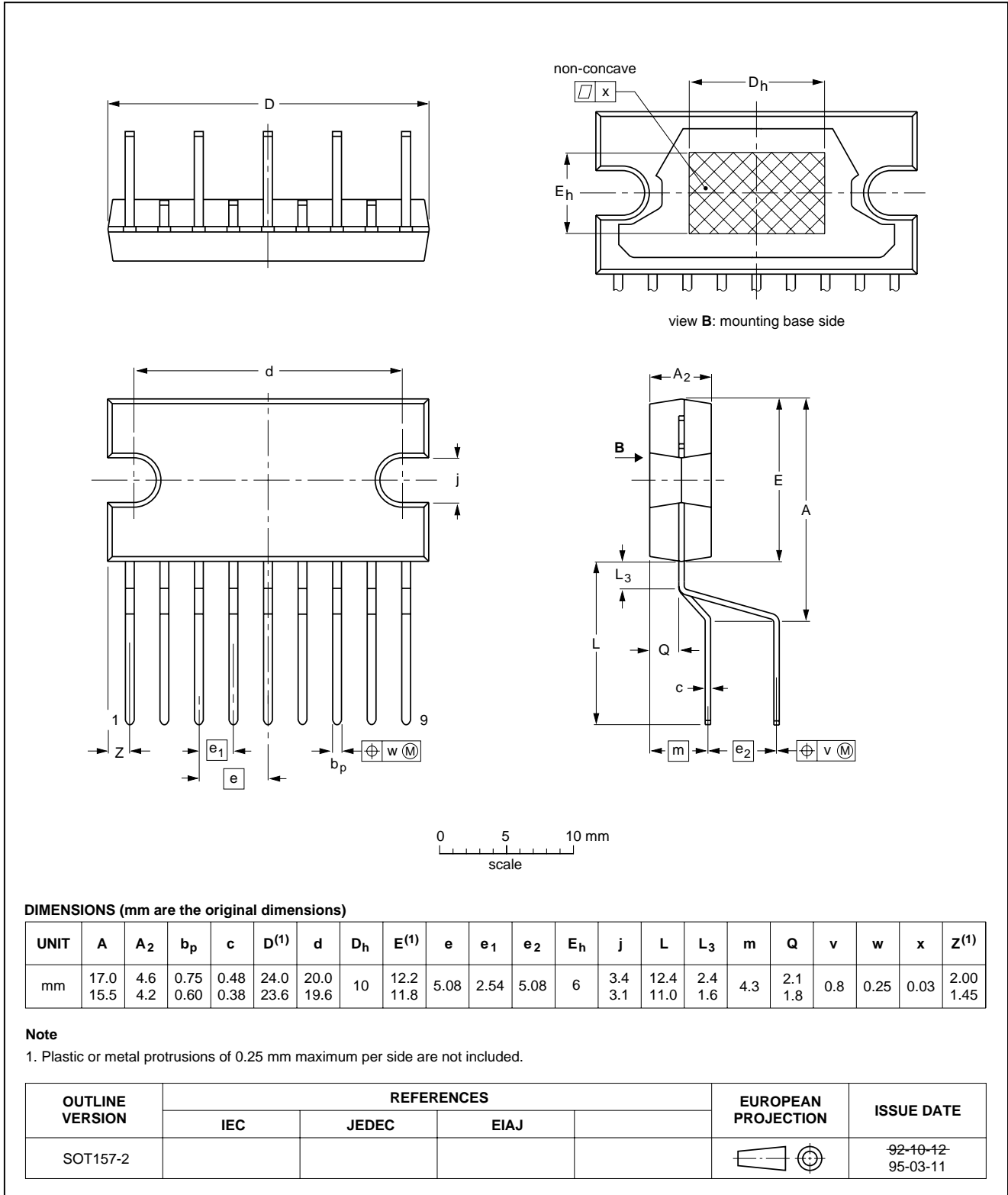

## Vertical deflection and guard circuit (110°)

TDA3654  
TDA3654Q

### SOLDERING

#### Introduction

There is no soldering method that is ideal for all IC packages. Wave soldering is often preferred when through-hole and surface mounted components are mixed on one printed-circuit board. However, wave soldering is not always suitable for surface mounted ICs, or for printed-circuits with high population densities. In these situations reflow soldering is often used.

This text gives a very brief insight to a complex technology. A more in-depth account of soldering ICs can be found in our "IC Package Databook" (order code 9398 652 90011).

#### Soldering by dipping or by wave

The maximum permissible temperature of the solder is 260 °C; solder at this temperature must not be in contact with the joint for more than 5 seconds. The total contact time of successive solder waves must not exceed 5 seconds.

The device may be mounted up to the seating plane, but the temperature of the plastic body must not exceed the specified maximum storage temperature ( $T_{stg\ max}$ ). If the printed-circuit board has been pre-heated, forced cooling may be necessary immediately after soldering to keep the temperature within the permissible limit.

#### Repairing soldered joints

Apply a low voltage soldering iron (less than 24 V) to the lead(s) of the package, below the seating plane or not more than 2 mm above it. If the temperature of the soldering iron bit is less than 300 °C it may remain in contact for up to 10 seconds. If the bit temperature is between 300 and 400 °C, contact may be up to 5 seconds.

### DEFINITIONS

Data sheet status	
Objective specification	This data sheet contains target or goal specifications for product development.
Preliminary specification	This data sheet contains preliminary data; supplementary data may be published later.
Product specification	This data sheet contains final product specifications.
Short-form specification	The data in this specification is extracted from a full data sheet with the same type number and title. For detailed information see the relevant data sheet or data handbook.
Limiting values	
Limiting values given are in accordance with the Absolute Maximum Rating System (IEC 134). Stress above one or more of the limiting values may cause permanent damage to the device. These are stress ratings only and operation of the device at these or at any other conditions above those given in the Characteristics sections of the specification is not implied. Exposure to limiting values for extended periods may affect device reliability.	
Application information	
Where application information is given, it is advisory and does not form part of the specification.	

### LIFE SUPPORT APPLICATIONS

These products are not designed for use in life support appliances, devices, or systems where malfunction of these products can reasonably be expected to result in personal injury. Philips customers using or selling these products for use in such applications do so at their own risk and agree to fully indemnify Philips for any damages resulting from such improper use or sale.