

# MC100LVEL16

## 3.3V ECL Differential Receiver

The MC100LVEL16 is a differential receiver. The device is functionally equivalent to the EL16 device, operating from a 3.3 V supply. The LVEL16 exhibits a wider  $V_{IHCMR}$  range than its EL16 counterpart. With output transition times and propagation delays comparable to the EL16 the LVEL16 is ideally suited for interfacing with high frequency sources at 3.3 V supplies.

Under open input conditions, the Q input will be pulled down to  $V_{EE}$  and the  $\bar{Q}$  input will be biased to  $V_{CC}/2$ . This condition will force the Q output low.

The  $V_{BB}$  pin, an internally generated voltage supply, is available to this device only. For single-ended input conditions, the unused differential input is connected to  $V_{BB}$  as a switching reference voltage.  $V_{BB}$  may also rebias AC coupled inputs. When used, decouple  $V_{BB}$  and  $V_{CC}$  via a 0.01  $\mu\text{F}$  capacitor and limit current sourcing or sinking to 0.5 mA. When not used,  $V_{BB}$  should be left open.

- 300 ps Propagation Delay
- High Bandwidth Output Transitions
- The 100 Series Contains Temperature Compensation
- PECL Mode Operating Range:  $V_{CC} = 3.0 \text{ V}$  to  $3.8 \text{ V}$  with  $V_{EE} = 0 \text{ V}$
- NECL Mode Operating Range:  $V_{CC} = 0 \text{ V}$  with  $V_{EE} = -3.0 \text{ V}$  to  $-3.8 \text{ V}$
- Internal Input Pulldown Resistors on D, Pullup and Pulldown Resistors on  $\bar{D}$
- Q Output will Default LOW with Inputs Open or at  $V_{EE}$

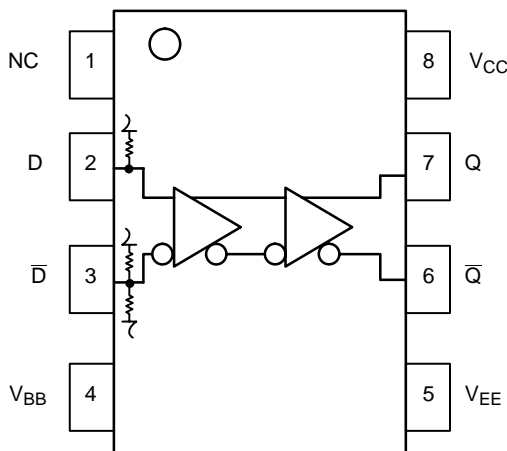

Figure 1. Logic Diagram and Pinout Assignment

### PIN DESCRIPTION

PIN	FUNCTION
D, $\bar{D}$	ECL Data Inputs
Q, $\bar{Q}$	ECL Data Outputs
$V_{BB}$	Reference Voltage Output
$V_{CC}$	Positive Supply
$V_{EE}$	Negative Supply
NC	No Connect



ON Semiconductor®

<http://onsemi.com>

### MARKING DIAGRAMS\*

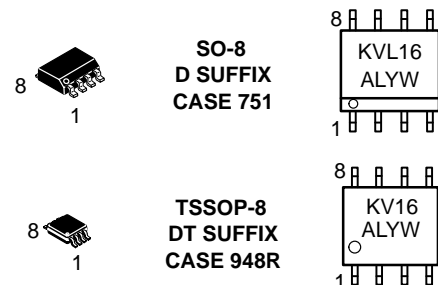

A = Assembly Location  
L = Wafer Lot  
Y = Year  
W = Work Week

\*For additional marking information, refer to Application Note AND8002/D.

### ORDERING INFORMATION

Device	Package	Shipping†
MC100LVEL16D	SO-8	98 Units / Rail
MC100LVEL16DR2	SO-8	2500 Tape & Reel
MC100LVEL16DT	TSSOP-8	98 Units / Rail
MC100LVEL16DTR2	TSSOP-8	2500 Tape & Reel

†For additional tape and reel information, refer to Brochure BRD8011/D.

# MC100LEVEL16

## ATTRIBUTES

Characteristics	Value
Internal Input Pulldown Resistor	75 kΩ
Internal Input Pullup Resistor	75 kΩ
ESD Protection	Human Body Model Machine Model Charged Device Model
	> 4 kV > 400 V > 2 kV
Moisture Sensitivity (Note 1)	Level 1
Flammability Rating	Oxygen Index: 28 to 34
	UL 94 V-0 @ 0.125 in
Transistor Count	79
Meets or Exceeds JEDEC Spec EIA/JESD78 IC Latchup Test	

1. Refer to Application Note AND8003/D for additional information.

## MAXIMUM RATINGS (Note 2)

Symbol	Parameter	Condition 1	Condition 2	Rating	Units
V <sub>CC</sub>	PECL Mode Power Supply	V <sub>EE</sub> = 0 V		8 to 0	V
V <sub>EE</sub>	NECL Mode Power Supply	V <sub>CC</sub> = 0 V		-8 to 0	V
V <sub>I</sub>	PECL Mode Input Voltage NECL Mode Input Voltage	V <sub>EE</sub> = 0 V V <sub>CC</sub> = 0 V	V <sub>I</sub> ≤ V <sub>CC</sub> V <sub>I</sub> ≥ V <sub>EE</sub>	6 to 0 -6 to 0	V V
I <sub>out</sub>	Output Current	Continuous Surge		50 100	mA mA
I <sub>BB</sub>	V <sub>BB</sub> Sink/Source			± 0.5	mA
T <sub>A</sub>	Operating Temperature Range			-40 to +85	°C
T <sub>stg</sub>	Storage Temperature Range			-65 to +150	°C
θ <sub>JA</sub>	Thermal Resistance (Junction-to-Ambient)	0 LFPM 500 LFPM	SO-8 SO-8	190 130	°C/W °C/W
θ <sub>JC</sub>	Thermal Resistance (Junction-to-Case)	Standard Board	SO-8	41 to 44 ± 5%	°C/W
θ <sub>JA</sub>	Thermal Resistance (Junction-to-Ambient)	0 LFPM 500 LFPM	TSSOP-8 TSSOP-8	185 140	°C/W °C/W
θ <sub>JC</sub>	Thermal Resistance (Junction-to-Case)	Standard Board	TSSOP-8	41 to 44 ± 5%	°C/W
T <sub>sol</sub>	Wave Solder	<2 to 3 sec @ 248°C		265	°C

2. Maximum Ratings are those values beyond which device damage may occur.

# MC100LEVEL16

## LVPECL DC CHARACTERISTICS $V_{CC} = 3.3\text{ V}$ ; $V_{EE} = 0.0\text{ V}$ (Note 3)

Symbol	Characteristic	-40 °C			25 °C			85 °C			Unit
		Min	Typ	Max	Min	Typ	Max	Min	Typ	Max	
$I_{EE}$	Power Supply Current		17	23		17	23		18	24	mA
$V_{OH}$	Output HIGH Voltage (Note 4)	2215	2295	2420	2275	2345	2420	2275	2345	2420	mV
$V_{OL}$	Output LOW Voltage (Note 4)	1470	1605	1745	1490	1595	1680	1490	1595	1680	mV
$V_{IH}$	Input HIGH Voltage (Single-Ended)	2135		2420	2135		2420	2135		2420	mV
$V_{IL}$	Input LOW Voltage (Single-Ended)	1490		1825	1490		1825	1490		1825	mV
$V_{BB}$	Output Voltage Reference	1.92		2.04	1.92		2.04	1.92		2.04	V
$V_{IHCMR}$	Input HIGH Voltage Common Mode Range (Differential) (Note 5) $V_{pp} < 500\text{ mV}$ $V_{pp} \geq 500\text{ mV}$	1.2		2.9	1.1		2.9	1.1		2.9	V
		1.5		2.9	1.4		2.9	1.4		2.9	V
$I_{IH}$	Input HIGH Current			150			150			150	$\mu\text{A}$
$I_{IL}$	Input LOW Current	D	0.5		0.5			0.5			$\mu\text{A}$
		$\bar{D}$	-600		-600			-600			$\mu\text{A}$

NOTE: Devices are designed to meet the DC specifications shown in the above table, after thermal equilibrium has been established. The circuit is in a test socket or mounted on a printed circuit board and transverse air flow greater than 500 lfm is maintained.

3. Input and output parameters vary 1:1 with  $V_{CC}$ .  $V_{EE}$  can vary  $\pm 0.3\text{ V}$ .

4. Outputs are terminated through a  $50\ \Omega$  resistor to  $V_{CC} - 2\text{ V}$ .

5.  $V_{IHCMR}$  min varies 1:1 with  $V_{EE}$ , max varies 1:1 with  $V_{CC}$ . The  $V_{IHCMR}$  range is referenced to the most positive side of the differential input signal. Normal operation is obtained if the HIGH level falls within the specified range and the peak-to-peak voltage lies between  $V_{ppmin}$  and  $1\text{ V}$ .

## LVNECL DC CHARACTERISTICS $V_{CC} = 0.0\text{ V}$ ; $V_{EE} = -3.3\text{ V}$ (Note 6)

Symbol	Characteristic	-40 °C			25 °C			85 °C			Unit
		Min	Typ	Max	Min	Typ	Max	Min	Typ	Max	
$I_{EE}$	Power Supply Current		17	23		17	23		18	24	mA
$V_{OH}$	Output HIGH Voltage (Note 7)	-1085	-1005	-880	-1025	-955	-880	-1025	-955	-880	mV
$V_{OL}$	Output LOW Voltage (Note 7)	-1830	-1695	-1555	-1810	-1705	-1620	-1810	-1705	-1620	mV
$V_{IH}$	Input HIGH Voltage (Single-Ended)	-1165		-880	-1165		-880	-1165		-880	mV
$V_{IL}$	Input LOW Voltage (Single-Ended)	-1810		-1475	-1810		-1475	-1810		-1475	mV
$V_{BB}$	Output Voltage Reference	-1.38		-1.26	-1.38		-1.26	-1.38		-1.26	V
$V_{IHCMR}$	Input HIGH Voltage Common Mode Range (Differential) (Note 8) $V_{pp} < 500\text{ mV}$ $V_{pp} \geq 500\text{ mV}$	-2.1		-0.4	-2.2		-0.4	-2.2		-0.4	V
		-1.8		-0.4	-1.9		-0.4	-1.9		-0.4	V
$I_{IH}$	Input HIGH Current			150			150			150	$\mu\text{A}$
$I_{IL}$	Input LOW Current	D	0.5		0.5			0.5			$\mu\text{A}$
		$\bar{D}$	-600		-600			-600			$\mu\text{A}$

NOTE: Devices are designed to meet the DC specifications shown in the above table, after thermal equilibrium has been established. The circuit is in a test socket or mounted on a printed circuit board and transverse air flow greater than 500 lfm is maintained.

6. Input and output parameters vary 1:1 with  $V_{CC}$ .  $V_{EE}$  can vary  $\pm 0.3\text{ V}$ .

7. Outputs are terminated through a  $50\ \Omega$  resistor to  $V_{CC} - 2\text{ V}$ .

8.  $V_{IHCMR}$  min varies 1:1 with  $V_{EE}$ , max varies 1:1 with  $V_{CC}$ . The  $V_{IHCMR}$  range is referenced to the most positive side of the differential input signal. Normal operation is obtained if the HIGH level falls within the specified range and the peak-to-peak voltage lies between  $V_{ppmin}$  and  $1\text{ V}$ .

# MC100LVEL16

**AC CHARACTERISTICS**  $V_{CC}= 3.3\text{ V}$ ;  $V_{EE}= 0.0\text{ V}$  or  $V_{CC}= 0.0\text{ V}$ ;  $V_{EE}= -3.3\text{ V}$  (Note 9)

Symbol	Characteristic	-40 °C			25 °C			85 °C			Unit
		Min	Typ	Max	Min	Typ	Max	Min	Typ	Max	
$f_{\max}$	Maximum Toggle Frequency		1.75			1.75			1.75		GHz
$t_{PLH}$ $t_{PHL}$	Propagation Delay to Output Differential Single-Ended	150 100	275 275	400 450	225 175	300 300	375 425	240 190	315 315	390 440	ps
$t_{SKEW}$	Duty Cycle Skew (Differential) (Note 10)		5	30		5	20		5	20	ps
$t_{JITTER}$	Random Clock Jitter (RMS)		0.7			0.7			0.7		ps
$V_{PP}$	Input Swing (Note 11)	150		1000	150		1000	150		1000	mV
$t_r$ $t_f$	Output Rise/Fall Times Q (20% - 80%)	120	220	320	120	220	320	120	220	320	ps

9.  $V_{EE}$  can vary  $\pm 0.3\text{ V}$ .

10. Duty cycle skew is the difference between a  $t_{PLH}$  and  $t_{PHL}$  propagation delay through a device.

11.  $V_{PP(\min)}$  is minimum input swing for which AC parameters guaranteed. The device has a DC gain of  $\approx 40$ .

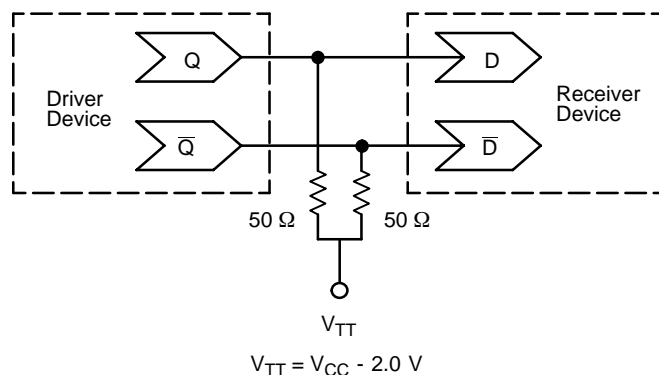

**Figure 2. Typical Termination for Output Driver and Device Evaluation  
(See Application Note AND8020 - Termination of ECL Logic Devices.)**

## Resource Reference of Application Notes

- AN1404** - ECLinPS Circuit Performance at Non-Standard  $V_{IH}$  Levels
- AN1405** - ECL Clock Distribution Techniques
- AN1406** - Designing with PECL (ECL at +5.0 V)
- AN1503** - ECLinPS I/O SPICE Modeling Kit
- AN1504** - Metastability and the ECLinPS Family
- AN1560** - Low Voltage ECLinPS SPICE Modeling Kit
- AN1568** - Interfacing Between LVDS and ECL
- AN1596** - ECLinPS Lite Translator ELT Family SPICE I/O Model Kit
- AN1650** - Using Wire-OR Ties in ECLinPS Designs
- AN1672** - The ECL Translator Guide
- AND8001** - Odd Number Counters Design
- AND8002** - Marking and Date Codes
- AND8020** - Termination of ECL Logic Devices
- AND8090** - AC Characteristics of ECL Devices

# MC100LVEL16

## PACKAGE DIMENSIONS

**SO-8**  
**D SUFFIX**  
 PLASTIC SOIC PACKAGE  
 CASE 751-07  
 ISSUE AA

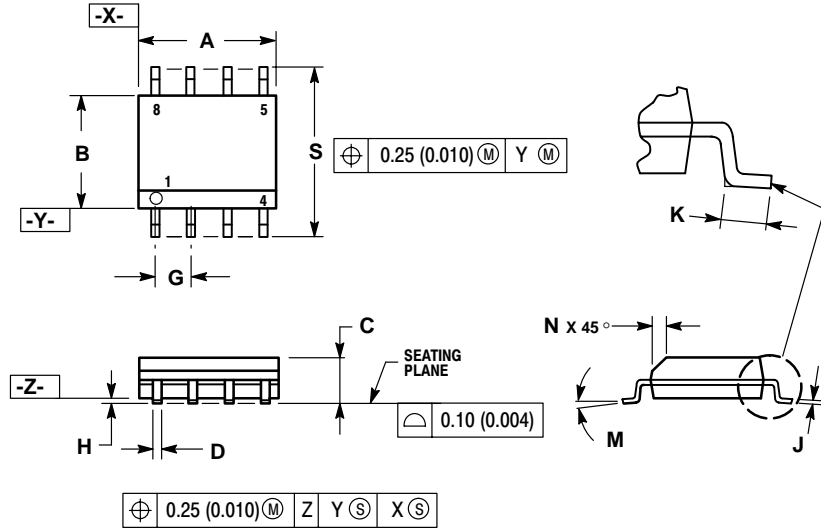

**NOTES:**

1. DIMENSIONING AND TOLERANCING PER ANSI Y14.5M, 1982.
2. CONTROLLING DIMENSION: MILLIMETER.
3. DIMENSION A AND B DO NOT INCLUDE MOLD PROTRUSION.
4. MAXIMUM MOLD PROTRUSION 0.15 (0.006) PER SIDE.
5. DIMENSION D DOES NOT INCLUDE DAMBAR PROTRUSION. ALLOWABLE DAMBAR PROTRUSION SHALL BE 0.127 (0.005) TOTAL IN EXCESS OF THE D DIMENSION AT MAXIMUM MATERIAL CONDITION.
6. 751-01 THRU 751-06 ARE OBSOLETE. NEW STANDARD IS 751-07.

DIM	MILLIMETERS		INCHES	
	MIN	MAX	MIN	MAX
A	4.80	5.00	0.189	0.197
B	3.80	4.00	0.150	0.157
C	1.35	1.75	0.053	0.069
D	0.33	0.51	0.013	0.020
G	1.27 BSC		0.050 BSC	
H	0.10	0.25	0.004	0.010
J	0.19	0.25	0.007	0.010
K	0.40	1.27	0.016	0.050
M	0°	8°	0°	8°
N	0.25	0.50	0.010	0.020
S	5.80	6.20	0.228	0.244

# MC100LVEL16

## PACKAGE DIMENSIONS

TSSOP-8  
DT SUFFIX  
PLASTIC TSSOP PACKAGE  
CASE 948R-02  
ISSUE A

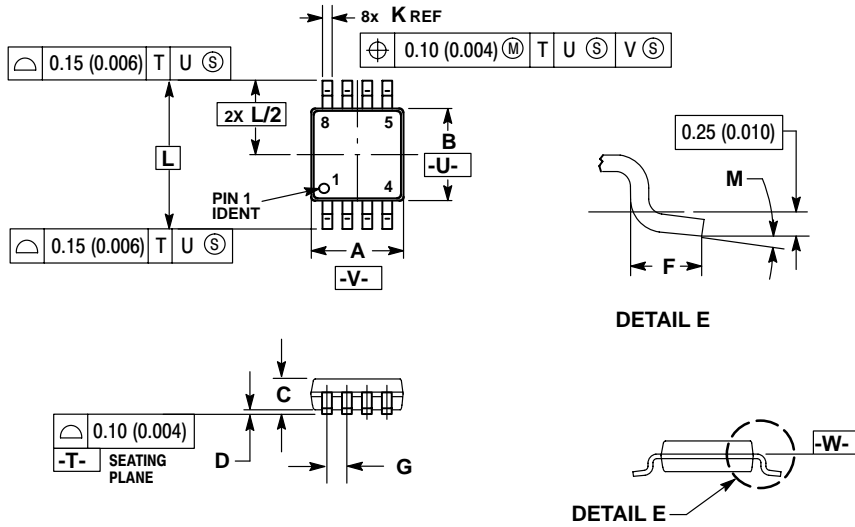

### NOTES:

1. DIMENSIONS AND TOLERANCING PER ASME Y14.5M, 1994.
2. CONTROLLING DIMENSION: MILLIMETER.
3. DIMENSION A DOES NOT INCLUDE MOLD FLASH. PROTRUSIONS OR GATE BURRS. MOLD FLASH OR GATE BURRS SHALL NOT EXCEED 0.15 (0.006) PER SIDE.
4. DIMENSION B DOES NOT INCLUDE INTERLEAD FLASH OR PROTRUSION. INTERLEAD FLASH OR PROTRUSION SHALL NOT EXCEED 0.25 (0.010) PER SIDE.
5. TERMINAL NUMBERS ARE SHOWN FOR REFERENCE ONLY.
6. DIMENSION A AND B ARE TO BE DETERMINED AT DATUM PLANE -W-.

DIM	MILLIMETERS		INCHES	
	MIN	MAX	MIN	MAX
A	2.90	3.10	0.114	0.122
B	2.90	3.10	0.114	0.122
C	0.80	1.10	0.031	0.043
D	0.05	0.15	0.002	0.006
F	0.40	0.70	0.016	0.028
G	0.65 BSC		0.026 BSC	
K	0.25	0.40	0.010	0.016
L	4.90 BSC		0.193 BSC	
M	0°	6°	0°	6°

ON Semiconductor and  are registered trademarks of Semiconductor Components Industries, LLC (SCILLC). SCILLC reserves the right to make changes without further notice to any products herein. SCILLC makes no warranty, representation or guarantee regarding the suitability of its products for any particular purpose, nor does SCILLC assume any liability arising out of the application or use of any product or circuit, and specifically disclaims any and all liability, including without limitation special, consequential or incidental damages. "Typical" parameters which may be provided in SCILLC data sheets and/or specifications can and do vary in different applications and actual performance may vary over time. All operating parameters, including "Typicals" must be validated for each customer application by customer's technical experts. SCILLC does not convey any license under its patent rights nor the rights of others. SCILLC products are not designed, intended, or authorized for use as components in systems intended for surgical implant into the body, or other applications intended to support or sustain life, or for any other application in which the failure of the SCILLC product could create a situation where personal injury or death may occur. Should Buyer purchase or use SCILLC products for any such unintended or unauthorized application, Buyer shall indemnify and hold SCILLC and its officers, employees, subsidiaries, affiliates, and distributors harmless against all claims, costs, damages, and expenses, and reasonable attorney fees arising out of, directly or indirectly, any claim of personal injury or death associated with such unintended or unauthorized use, even if such claim alleges that SCILLC was negligent regarding the design or manufacture of the part. SCILLC is an Equal Opportunity/Affirmative Action Employer.

### PUBLICATION ORDERING INFORMATION

#### Literature Fulfillment:

Literature Distribution Center for ON Semiconductor  
P.O. Box 5163, Denver, Colorado 80217 USA  
Phone: 303-675-2175 or 800-344-3860 Toll Free USA/Canada  
Fax: 303-675-2176 or 800-344-3867 Toll Free USA/Canada  
Email: ONlit@hibbertco.com

N. American Technical Support: 800-282-9855 Toll Free USA/Canada

JAPAN: ON Semiconductor, Japan Customer Focus Center  
2-9-1 Kamimeguro, Meguro-ku, Tokyo, Japan 153-0051  
Phone: 81-3-5773-3850

ON Semiconductor Website: <http://onsemi.com>

For additional information, please contact your local Sales Representative.