

FEATURES

- Permits multiplexing from N lines to 1 line
- Performs parallel-to-serial conversion
- Strobe (Enable) line provided for cascading (N lines to n lines)
- Non-inverting
- Higher Speed compared to 9LS/54LS and 9LS/74LS
- 8mA sink current over full military temperature range
- 50mV improved V_{OL} compared to 9LS/74LS
- 440 μ A source current
- 100% reliability assurance testing in compliance with MIL-STD-883

DESCRIPTION

The 25LS153 is a high speed Dual 4-Line to 1-Line Multiplexer with common select inputs and separate strobe (enable) inputs for each half. Each half can select one bit of four and present it at the output in non-inverted form.

LOGIC DIAGRAM

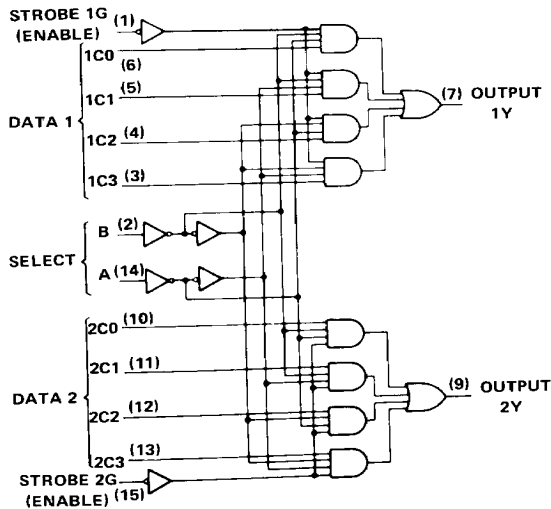

PIN-OUT DIAGRAM

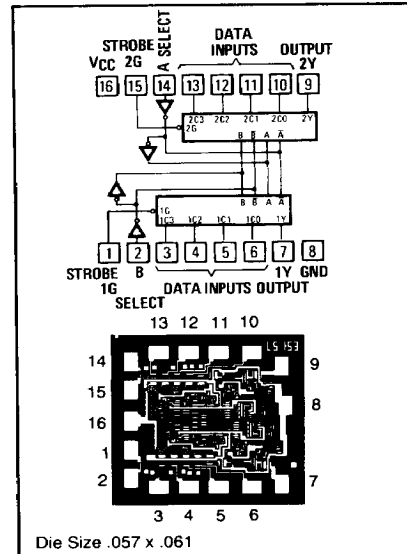

FUNCTION TABLE

SELECT INPUTS		DATA INPUTS				STROBE	OUTPUT
B	A	C0	C1	C2	C3	G	Y
X	X	X	X	X	X	H	L
L	L	L	X	X	X	L	L
L	L	H	X	X	X	L	H
L	H	X	L	X	X	L	L
L	H	X	H	X	X	L	H
H	L	X	X	L	X	L	L
H	L	X	X	H	X	L	H
H	H	X	X	X	L	L	L
H	H	X	X	X	H	L	H

Select inputs A and B are common to both sections.
H = high level, L = low level, X = don't care



Recommended Operating Conditions

	Military			Commercial			Unit
	Min	Nom	Max	Min	Nom	Max	
Supply voltage, V_{CC}	4.5	5	5.5	4.75	5	5.5	V
High-level output current, I_{OH}			-440			-440	μA
Low-level output current, I_{OL}	4		8	4		8	mA
Operating free-air temperature, T_A	-55		125	0		70	$^{\circ}C$

Electrical Characteristics Over Recommended Free-Air Temperature Range (Unless Otherwise Noted)

Parameter	Test Conditions*	Military			Commercial			Unit
		Min	Typ**	Max	Min	Typ**	Max	
V_{IH}		2			2			V
V_{IL}				0.7			0.8	V
V_I	$V_{CC} = \text{MIN}, I_I = -18\text{mA}$			-1.5			-1.5	V
V_{OH}	$V_{CC} = \text{MIN}, V_{IH} = 2\text{V}, V_{IL} = V_{IL\text{max}}, I_{OH} = -440\mu A$	2.5	3.4		2.7	3.4		V
V_{OL}	$V_{CC} = \text{MIN}, V_{IH} = 2\text{V}, V_{IL} = V_{IL\text{max}}$							V
	$I_{OL} = 4\text{mA}$		0.25	0.40			0.40	
	$I_{OL} = 8\text{mA}$		0.3	0.45		0.35	0.45	
I_I	$V_{CC} = \text{MAX}, V_I = 7.0\text{V}$			0.1			0.1	mA
I_{IH}	$V_{CC} = \text{MAX}, V_I = 2.7\text{V}$			20			20	μA
I_{IL}	$V_{CC} = \text{MAX}, V_I = 0.4\text{V}$			-0.36			-0.36	mA
$I_{OS}\dagger$	$V_{CC} = \text{MAX}$	-15		-85	-15		-85	mA
$I_{CCL}\dagger\dagger$	$V_{CC} = \text{MAX}$		6.2	10		6.2	10	mA

*For conditions shown as MIN or MAX, use the appropriate value specified under recommended operating conditions for the applicable device type.

**All typical values are at $V_{CC} = 5\text{V}, T_A = 25^{\circ}C$.

†Not more than one output should be shorted at a time.

†† I_{CCL} is measured with the outputs open and all inputs grounded.

Switching Characteristics, $V_{CC} = 5\text{V}, T_A = +25^{\circ}C$

Parameter	From (input)	To (output)	+25 $^{\circ}C$			Unit
			Min	Typ	Max	
Test Conditions: $C_L = 15\text{pF}, R_L = 2\text{k}\Omega$ (See Fig. A, page 2-174)						
t_{PLH}	Data	Y		7	13	ns
t_{PLH}	Data	Y		10	16	ns
t_{PLH}	Select	Y		16	24	ns
t_{PLH}	Select	Y		20	25	ns
t_{PLH}	Strobe	Y		13	n,20	ns
t_{PLH}	Strobe	Y		15	20	ns

