

74ACT715•74ACT715-R Programmable Video Sync Generator

General Description

The ACT715 and ACT715-R are 20-pin TTL-input compatible devices capable of generating Horizontal, Vertical and Composite Sync and Blank signals for televisions and monitors. All pulse widths are completely definable by the user. The devices are capable of generating signals for both interlaced and noninterlaced modes of operation. Equalization and serration pulses can be introduced into the Composite Sync signal when needed.

Four additional signals can also be made available when Composite Sync or Blank are used. These signals can be used to generate horizontal or vertical gating pulses, cursor position or vertical Interrupt signal.

These devices make no assumptions concerning the system architecture. Line rate and field/frame rate are all a function of the values programmed into the data registers, the status register, and the input clock frequency.

The ACT715 is mask programmed to default to a Clock Disable state. Bit 10 of the Status Register, Register 0, defaults to a logic "0". This facilitates (re)programming before operation.

The ACT715-R is the same as the ACT715 in all respects except that the ACT715-R is mask programmed to default

to a Clock Enabled state. Bit 10 of the Status Register defaults to a logic "1". Although completely (re)programmable, the ACT715-R version is better suited for applications using the default 14.31818 MHz RS-170 register values. This feature allows power-up directly into operation, following a single CLEAR pulse.

Features

- Maximum Input Clock Frequency > 130 MHz
- Interlaced and non-interlaced formats available
- Separate or composite horizontal and vertical Sync and Blank signals available
- Complete control of pulse width via register programming
- All inputs are TTL compatible
- 8 mA drive on all outputs
- Default RS170/NTSC values mask programmed into registers
- ACT715-R is mask programmed to default to a Clock Enable state for easier start-up into 14.31818 MHz RS170 timing

Ordering Code:

Order Number	Package Number	Package Description
74ACT715SC	M20B	20-Lead Small Outline Integrated Circuit (SOIC), JEDEC MS-013, 0.300" Wide
74ACT715PC	N20A	20-Lead Plastic Dual-In-Line Package (PDIP), JEDEC MS-001, 0.300" Wide
74ACT715-RSC	M20B	20-Lead Small Outline Integrated Circuit (SOIC), JEDEC MS-013, 0.300" Wide
74ACT715-RPC	N20A	20-Lead Plastic Dual-In-Line Package (PDIP), JEDEC MS-001, 0.300" Wide

Device also available in Tape and Reel. Specify by appending suffix letter "X" to the ordering code.

Connection Diagram

Pin Assignment for DIP and SOIC

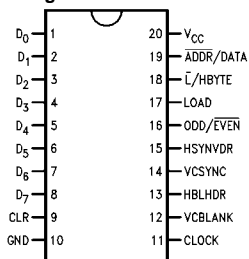

FACT™ is a trademark of Fairchild Semiconductor Corporation.

Logic Block Diagram

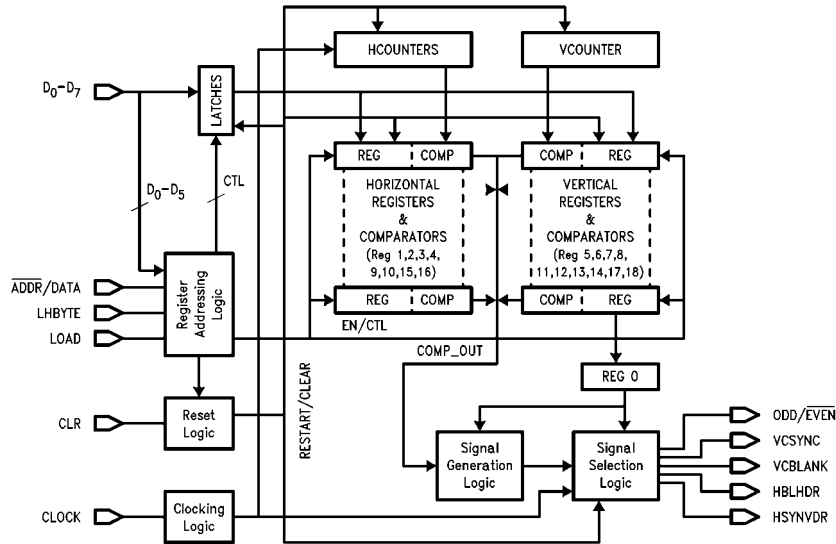

Pin Description

There are a Total of 13 inputs and 5 outputs on the ACT715.

Data Inputs D0–D7: The Data Input pins connect to the Address Register and the Data Input Register.

ADDR/DATA: The ADDR/DATA signal is latched into the device on the falling edge of the LOAD signal. The signal determines if an address (0) or data (1) is present on the data bus.

L/HBYTE: The L/HBYTE signal is latched into the device on the falling edge of the LOAD signal. The signal determines if data will be read into the 8 LSB's (0) or the 4 MSB's (1) of the Data Registers. A 1 on this pin when an ADDR/DATA is a 0 enables Auto-Load Mode.

LOAD: The LOAD control pin loads data into the Address or Data Registers on the rising edge. ADDR/DATA and L/HBYTE data is loaded into the device on the falling edge of the LOAD. The LOAD pin has been implemented as a Schmitt trigger input for better noise immunity.

CLOCK: System CLOCK input from which all timing is derived. The clock pin has been implemented as a Schmitt trigger for better noise immunity. The CLOCK and the LOAD signal are asynchronous and independent. Output state changes occur on the falling edge of CLOCK.

CLR: The CLEAR pin is an asynchronous input that initializes the device when it is HIGH. Initialization consists of setting all registers to their mask programmed values, and

initializing all counters, comparators and registers. The CLEAR pin has been implemented as a Schmitt trigger for better noise immunity. A CLEAR pulse should be asserted by the user immediately after power-up to ensure proper initialization of the registers—even if the user plans to (re)program the device.

Note: A CLEAR pulse will disable the CLOCK on the ACT715 and will enable the CLOCK on the ACT715-R.

ODD/EVEN: Output that identifies if display is in odd (HIGH) or even (LOW) field of interlace when device is in interlaced mode of operation. In noninterlaced mode of operation this output is always HIGH. Data can be serially scanned out on this pin during Scan Mode.

VCSYNC: Outputs Vertical or Composite Sync signal based on value of the Status Register. Equalization and Serration pulses will (if enabled) be output on the VCSYNC signal in composite mode only.

VCBLANK: Outputs Vertical or Composite Blanking signal based on value of the Status Register.

HBLHDR: Outputs Horizontal Blanking signal, Horizontal Gating signal or Cursor Position based on value of the Status Register.

HSYNVDR: Outputs Horizontal Sync signal, Vertical Gating signal or Vertical Interrupt signal based on value of Status Register.

Register Description

All of the data registers are 12 bits wide. Width's of all pulses are defined by specifying the start count and end count of all pulses. Horizontal pulses are specified with-respect-to the number of clock pulses per line and vertical pulses are specified with-respect-to the number of lines per frame.

REG0—STATUS REGISTER

The Status Register controls the mode of operation, the signals that are output and the polarity of these outputs. The default value for the Status Register is 0 (000 Hex) for the ACT715 and is "1024" (400 Hex) for the ACT715-R.

Bits 0–2

B ₂	B ₁	B ₀	VCBLANK	VCSYNC	HBLHDR	HSYNVDR
0	0	0	CBLANK	CSYNC	HGATE	VGATE
(DEFAULT)						
0	0	1	VBLANK	CSYNC	HBLANK	VGATE
0	1	0	CBLANK	VSYNC	HGATE	HSYNC
0	1	1	VBLANK	VSYNC	HBLANK	HSYNC
1	0	0	CBLANK	CSYNC	CUSOR	VINT
1	0	1	VBLANK	CSYNC	HBLANK	VINT
1	1	0	CBLANK	VSYNC	CUSOR	HSYNC
1	1	1	VBLANK	VSYNC	HBLANK	HSYNC

Bits 3–4

B ₄	B ₃	Mode of Operation
0	0	Interlaced Double Serration and Equalization
(DEFAULT)		
0	1	Non Interlaced Double Serration
1	0	Illegal State
1	1	Non Interlaced Single Serration and Equalization

Double Equalization and Serration mode will output equalization and serration pulses at twice the HSYNC frequency (i.e., 2 equalization or serration pulses for every HSYNC pulse). Single Equalization and Serration mode will output an equalization or serration pulse for every HSYNC pulse. In Interlaced mode equalization and serration pulses will be output during the VBLANK period of every odd and even field. Interlaced Single Equalization and Serration mode is not possible with this part.

Bits 5–8

Bits 5 through 8 control the polarity of the outputs. A value of zero in these bit locations indicates an output pulse active LOW. A value of 1 indicates an active HIGH pulse.

B5—	VCBLANK Polarity
B6—	VCSYNC Polarity
B7—	HBLHDR Polarity
B8—	HSYNVDR Polarity

Bits 9–11

Bits 9 through 11 enable several different features of the device.

B9—	Enable Equalization/Serration Pulses (0)
	Disable Equalization/Serration Pulses (1)

B10—	Disable System Clock (0)
	Enable System Clock (1)
	Default values for B10 are "0" in the ACT715 and "1" in the ACT715-R.

B11—	Disable Counter Test Mode (0)
	Enable Counter Test Mode (1)
	This bit is not intended for the user but is for internal testing only.

HORIZONTAL INTERVAL REGISTERS

The Horizontal Interval Registers determine the number of clock cycles per line and the characteristics of the Horizontal Sync and Blank pulses.

REG1—	Horizontal Front Porch
REG2—	Horizontal Sync Pulse End Time
REG3—	Horizontal Blanking Width
REG4—	Horizontal Interval Width # of Clocks per Line

VERTICAL INTERVAL REGISTERS

The Vertical Interval Registers determine the number of lines per frame, and the characteristics of the Vertical Blank and Sync Pulses.

REG5—	Vertical Front Porch
REG6—	Vertical Sync Pulse End Time
REG7—	Vertical Blanking Width
REG8—	Vertical Interval Width # of Lines per Frame

EQUALIZATION AND SERRATION PULSE SPECIFICATION REGISTERS

These registers determine the width of equalization and serration pulses and the vertical interval over which they occur.

REG 9—	Equalization Pulse Width End Time
REG10—	Serration Pulse Width End Time
REG11—	Equalization/Serration Pulse Vertical Interval Start Time
REG12—	Equalization/Serration Pulse Vertical Interval End Time

VERTICAL INTERRUPT SPECIFICATION REGISTERS

These Registers determine the width of the Vertical Interrupt signal if used.

REG13—	Vertical Interrupt Activate Time
REG14—	Vertical Interrupt Deactivate Time

CUSOR LOCATION REGISTERS

These 4 registers determine the cursor position location, or they generate separate Horizontal and Vertical Gating signals.

REG15—	Horizontal Cursor Position Start Time
REG16—	Horizontal Cursor Position End Time
REG17—	Vertical Cursor Position Start Time
REG18—	Vertical Cursor Position End Time

Signal Specification

HORIZONTAL SYNC AND BLANK SPECIFICATIONS

All horizontal signals are defined by a start and end time. The start and end times are specified in number of clock cycles per line. The start of the horizontal line is considered pulse 1 not 0. All values of the horizontal timing registers are referenced to the falling edge of the Horizontal Blank signal (see Figure 1). Since the first CLOCK edge, CLOCK #1, causes the first falling edge of the Horizontal Blank ref-

erence pulse, edges referenced to this first Horizontal edge are $n + 1$ CLOCKS away, where "n" is the width of the timing in question. Registers 1, 2, and 3 are programmed in this manner. The horizontal counters start at 1 and count until HMAX. The value of HMAX must be divisible by 2. This limitation is imposed because during interlace operation this value is internally divided by 2 in order to generate serration and equalization pulses at $2 \times$ the horizontal frequency. Horizontal signals will change on the falling edge of the CLOCK signal. Signal specifications are shown below.

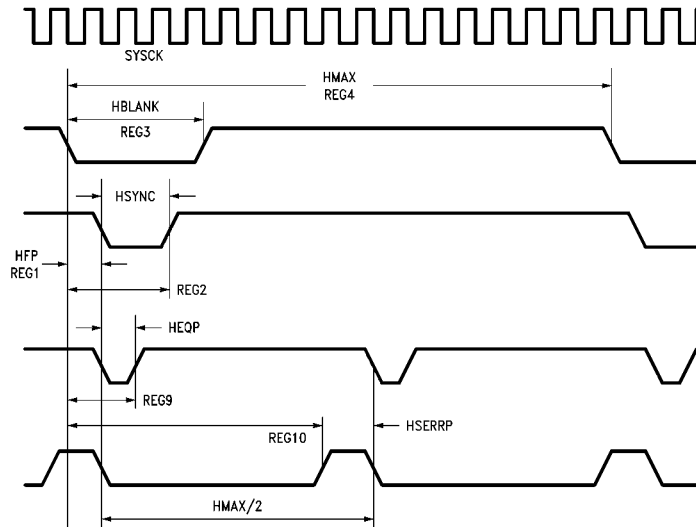

FIGURE 1. Horizontal Waveform Specification

Horizontal Period (HPER) = $\text{REG}(4) \times \text{ckper}$
 Horizontal Blanking Width: = $[\text{REG}(3) - 1] \times \text{ckper}$
 Horizontal Sync Width: = $[\text{REG}(2) - \text{REG}(1)] \times \text{ckper}$
 Horizontal Front Porch: = $[\text{REG}(1) - 1] \times \text{ckper}$

Vertical Syncing Width = $[\text{REG}(6) - \text{REG}(5)] \times \text{hper}/n$
 Vertical Front Porch = $[\text{REG}(5) - 1] \times \text{hper}/n$
 where $n = 1$ for noninterlaced
 $n = 2$ for interlaced

VERTICAL SYNC AND BLANK SPECIFICATION

All vertical signals are defined in terms of number of lines per frame. This is true in both interlaced and noninterlaced modes of operation. Care must be taken to not specify the Vertical Registers in terms of lines per field. Since the first CLOCK edge, CLOCK #1, causes the first falling edge of the Vertical Blank (first Horizontal Blank) reference pulse, edges referenced to this first edge are $n + 1$ lines away, where "n" is the width of the timing in question. Registers 5, 6, and 7 are programmed in this manner. Also, in the interlaced mode, vertical timing is based on half-lines. Therefore registers 5, 6, and 7 must contain a value twice the total horizontal (odd and even) plus 1 (as described above). In non-interlaced mode, all vertical timing is based on whole-lines. Register 8 is always based on whole-lines and does not add 1 for the first clock. The vertical counter starts at the value of 1 and counts until the value of VMAX. No restrictions exist on the values placed in the vertical registers. Vertical Blank will change on the leading edge of HBLANK. Vertical Sync will change on the leading edge of HSYNC. (See Figure 2.) Vertical Frame Period (VPER) = $\text{REG}(8) \times \text{hper}$

Vertical Field Period (VPER/n) = $\text{REG}(8) \times \text{hper}/n$
 Vertical Blanking Width = $[\text{REG}(7) - 1] \times \text{hper}/n$

COMPOSITE SYNC AND BLANK SPECIFICATION

Composite Sync and Blank signals are created by logically ANDing (ORing) the active LOW (HIGH) signals of the corresponding vertical and horizontal components of these signals. The Composite Sync signal may also include serration and/or equalization pulses. The Serration pulse interval occurs in place of the Vertical Sync interval. Equalization pulses occur preceding and/or following the Serration pulses. The width and location of these pulses can be programmed through the registers shown below. (See Figure 3.)

Horizontal Equalization PW = $[\text{REG}(9) - \text{REG}(1)] \times \text{ckper}$
 $\text{REG } 9 = (\text{HFP}) + (\text{HEQP}) + 1$

Horizontal Serration PW: = $[\text{REG}(4)/n + \text{REG}(1) - \text{REG}(10)] \times \text{ckper}$
 $\text{REG } 10 = (\text{HFP}) + (\text{HPER}/2) - (\text{HSERR}) + 1$

Where $n = 1$ for noninterlaced single serration/equalization
 $n = 2$ for noninterlaced double serration/equalization
 $n = 2$ for interlaced operation

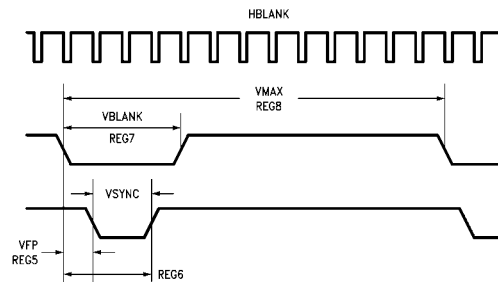

FIGURE 2. Vertical Waveform Specification

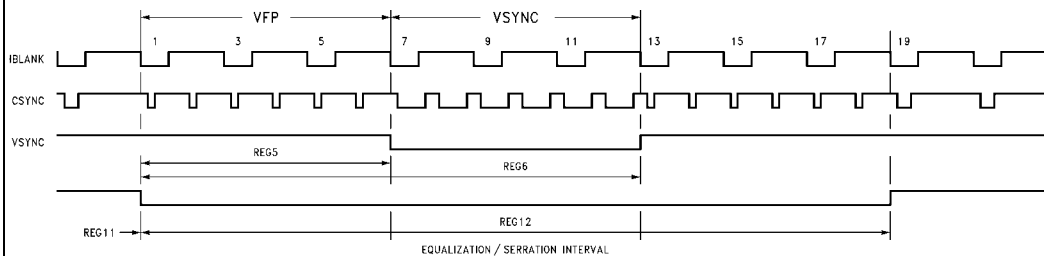

FIGURE 3. Equalization/Serration Interval Programming

HORIZONTAL AND VERTICAL GATING SIGNALS

Horizontal Drive and Vertical Drive outputs can be utilized as general purpose Gating Signals. Horizontal and Vertical Gating Signals are available for use when Composite Sync and Blank signals are selected and the value of Bit 2 of the Status Register is 0. The Vertical Gating signal will change in the same manner as that specified for the Vertical Blank.

Horizontal Gating Signal Width = $[\text{REG}(16) - \text{REG}(15)] \times \text{ckper}$

Vertical Gating Signal Width: = $[\text{REG}(18) - \text{REG}(17)] \times \text{hper}$

CURSOR POSITION AND VERTICAL INTERRUPT

The Cursor Position and Vertical Interrupt signal are available when Composite Sync and Blank signals are selected and Bit 2 of the Status Register is set to the value of 1. The Cursor Position generates a single pulse of n clocks wide during every line that the cursor is specified. The signals are generated by logically ORing (ANDing) the active LOW (HIGH) signals specified by the registers used for generating Horizontal and Vertical Gating signals. The Vertical Interrupt signal generates a pulse during the vertical interval specified. The Vertical Interrupt signal will change in the same manner as that specified for the Vertical Blanking signal.

Horizontal Cursor Width = $[\text{REG}(16) - \text{REG}(15)] \times \text{ckper}$

Vertical Cursor Width = $[\text{REG}(18) - \text{REG}(17)] \times \text{hper}$

Vertical Interrupt Width = $[\text{REG}(14) - \text{REG}(13)] \times \text{hper}$

Addressing Logic

The register addressing logic is composed of two blocks of logic. The first is the address register and counter (ADDRCNTR), and the second is the address decode (ADDRDEC).

ADDRCNTR LOGIC

Addresses for the data registers can be generated by one of two methods. Manual addressing requires that each byte of each register that needs to be loaded needs to be addressed. To load both bytes of all 19 registers would require a total of 57 load cycles (19 address and 38 data cycles). Auto Addressing requires that only the initial register value be specified. The Auto Load sequence would require only 39 load cycles to completely program all registers (1 address and 38 data cycles). In the auto load sequence the low order byte of the data register will be

written first followed by the high order byte on the next load cycle. At the time the High Byte is written the address counter is incremented by 1. The counter has been implemented to loop on the initial value loaded into the address register. For example: If a value of 0 was written into the address register then the counter would count from 0 to 18 before resetting back to 0. If a value of 15 was written into the address register then the counter would count from 15 to 18 before looping back to 15. If a value greater than or equal to 18 is placed into the address register the counter will continuously loop on this value. Auto addressing is initiated on the falling edge of LOAD when ADDRDATA is 0 and LHBYTE is 1. Incrementing and loading of data registers will not commence until the falling edge of LOAD after ADDRDATA goes to 1. The next rising edge of LOAD will load the first byte of data. Auto Incrementing is disabled on the falling edge of LOAD after ADDRDATA and LHBYTE goes low.

Manual Addressing Mode

Cycle #	Load Falling Edge	Load Rising Edge
1	Enable Manual Addressing	Load Address m
2	Enable Lbyte Data Load	Load Lbyte m
3	Enable Hbyte Data Load	Load Hbyte m
4	Enable Manual Addressing	Load Address n
5	Enable Lbyte Data Load	Load Lbyte n
6	Enable Hbyte Data Load	Load Hbyte n

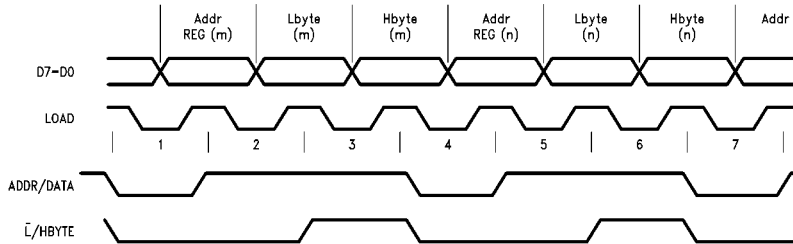

Auto Addressing Mode

Cycle #	Load Falling Edge	Load Rising Edge
1	Enable Auto Addressing	Load Start Address n
2	Enable Lbyte Data Load	Load Lbyte (n)
3	Enable Hbyte Data Load	Load Hbyte (n); Inc Counter
4	Enable Lbyte Data Load	Load Lbyte (n+1)
5	Enable Hbyte Data Load	Load Hbyte (n+1); Inc Counter
6	Enable Manual Addressing	Load Address

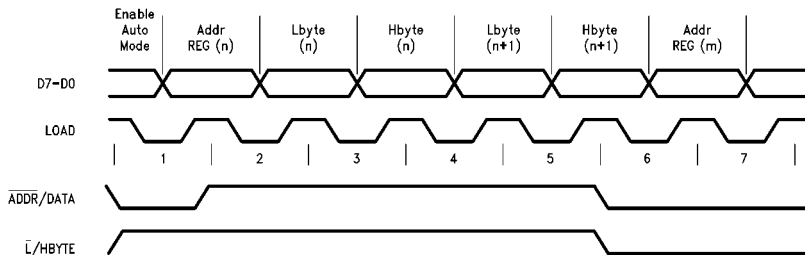

ADDRDEC LOGIC

The ADDRDEC logic decodes the current address and generates the enable signal for the appropriate register. The enable values for the registers and counters change on the falling edge of LOAD. Two types of ADDRDEC logic is enabled by 2 pair of addresses, Addresses 22 or 54 (Vectored Restart logic) and Addresses 23 or 55 (Vectored Clear logic). Loading these addresses will enable the appropriate logic and put the part into either a Restart (all counter registers are reinitialized with preprogrammed data) or Clear (all registers are cleared to zero) state. Reloading the same ADDRDEC address will not cause any change in the state of the part. The outputs during these states are frozen and the internal CLOCK is disabled. Clocking the part during a Vectored Restart or Vectored Clear state will have no effect on the part. To resume operation in the new state, or disable the Vectored Restart or Vectored Clear state, another non-ADDRDEC address must be loaded. Operation will begin in the new state on the rising edge of the non-ADDRDEC load pulse. It is recommended that an unused address be loaded following an ADDRDEC operation to prevent data registers from accidentally being corrupted. The following Addresses are used by the device.

Address 0	Status Register REG0
Address 1–18	Data Registers REG1–REG18
Address 19–21	Unused
Address 22/54	Restart Vector (Restarts Device)
Address 23/55	Clear Vector (Zeros All Registers)
Address 24–31	Unused
Address 32–50	Register Scan Addresses
Address 51–53	Counter Scan Addresses
Address 56–63	Unused

At any given time only one register at most is selected. It is possible to have no registers selected.

VECTORED RESTART ADDRESS

The function of addresses 22 (16H) or 54 (36H) are similar to that of the CLR pin except that the preprogramming of the registers is not affected. It is recommended but not required that this address is read after the initial device configuration load sequence. A 1 on the ADDRDATA pin (Auto Addressing Mode) will not cause this address to automatically increment. The address will loop back onto itself regardless of the state of ADDRDATA unless the address on the Data inputs has been changed with ADDRDATA at 0.

VECTORED CLEAR ADDRESS

Addresses 23 (17H) or 55 (37H) is used to clear all registers to zero simultaneously. This function may be desirable to use prior to loading new data into the Data or Status Registers. This address is read into the device in a similar fashion as all of the other registers. A 1 on the ADDRDATA pin (Auto Addressing Mode) will not cause this address to automatically increment. The address will loop back onto itself regardless of the state of ADDRDATA unless the address on the Data inputs has been changed with ADDRDATA at 0.

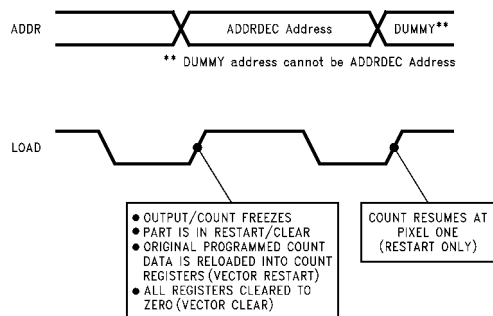

FIGURE 4. ADDRDEC Timing

GEN LOCKING

The ACT715 and ACT715-R is designed for master SYNC and BLANK signal generation. However, the devices can be synchronized (slaved) to an external timing signal in a limited sense. Using Vectored Restart, the user can reset the counting sequence to a given location, the beginning, at a given time, the rising edge of the LOAD that removes Vector Restart. At this time the next CLOCK pulse will be CLOCK 1 and the count will restart at the beginning of the first odd line.

Preconditioning the part during normal operation, before the desired synchronizing pulse, is necessary. However, since LOAD and CLOCK are asynchronous and independent, this is possible without interruption or data and performance corruption. If the defaulted 14.31818 MHz RS-170 values are being used, preconditioning and restarting can be minimized by using the CLEAR pulse instead of the Vectored Restart operation. The ACT715-R is better suited for this application because it eliminates the need to program a 1 into Bit 10 of the Status Register to enable the CLOCK. Gen Locking to another count location other than the very beginning or separate horizontal/vertical resetting is not possible with the ACT715 nor the ACT715-R.

SCAN MODE LOGIC

A scan mode is available in the ACT715 that allows the user to non-destructively verify the contents of the registers. Scan mode is invoked through reading a scan address into the address register. The scan address of a given register is defined by the Data register address + 32. The internal Clocking signal is disabled when a scan address is read. Disabling the clock freezes the device in its present state. Data can then be serially scanned out of the data registers through the ODD/EVEN Pin. The LSB will be scanned out first. Since each register is 12 bits wide, completely scanning out data of the addressed register will require 12 CLOCK pulses. More than 12 CLOCK pulses on the same register will only cause the MSB to repeat on the output. Re-scanning the same register will require that register to be reloaded. The value of the two horizontal counters and 1 vertical counter can also be scanned out by using address numbers 51–53. Note that before the part will scan out the data, the LOAD signal must be brought back HIGH.

Normal device operation can be resumed by loading in a non-scan address. As the scanning of the registers is a non-destructive scan, the device will resume correct operation from the point at which it was halted.

RS170 Default Register Values

The tables below show the values programmed for the RS170 Format (using a 14.31818 MHz clock signal) and how they compare against the actual EIA RS170 Specifications. The default signals that will be output are CSYNC, CBLANK, HDRIVE and VDRIVE. The device initially starts

at the beginning of the odd field of interlace. All signals have active low pulses and the clock is disabled at power up. Registers 13 and 14 are not involved in the actual signal information. If the Vertical Interrupt was selected so that a pulse indicating the active lines would be output.

Reg	D Value H		Register Description
REG0	0	000	Status Register (715)
REG0	1024	400	Status Register (715-R)
REG1	23	017	HFP End Time
REG2	91	05B	HSYNC Pulse End Time
REG3	157	09D	HBLANK Pulse End Time
REG4	910	38E	Total Horizontal Clocks
REG5	7	007	VFP End Time
REG6	13	00D	VSYNC Pulse End Time
REG7	41	029	VBLANK Pulse End Time
REG8	525	20D	Total Vertical Lines
REG9	57	039	Equalization Pulse End Time
REG10	410	19A	Serration Pulse Start Time
REG11	1	001	Pulse Interval Start Time
REG12	19	013	Pulse Interval End Time
REG13	41	029	Vertical Interrupt Activate Time
REG14	526	20E	Vertical Interrupt Deactivate Time
REG15	911	38F	Horizontal Drive Start Time
REG16	92	05C	Horizontal Drive End Time
REG17	1	001	Vertical Drive Start Time
REG18	21	015	Vertical Drive End Time

	Rate	Period
Input Clock	14.31818 MHz	69.841 ns
Line Rate	15.73426 kHz	63.556 μ s
Field Rate	59.94 Hz	16.683 ms
Frame Rate	29.97 Hz	33.367 ms

RS170 Horizontal Data

Signal	Width	μ s	%H	Specification (μ s)
HFP	22 Clocks	1.536		1.5 \pm 0.1
HSYNC Width	68 Clocks	4.749	7.47	4.7 \pm 0.1
HBLANK Width	156 Clocks	10.895	17.15	10.9 \pm 0.2
HDRIVE Width	91 Clocks	6.356	10.00	0.1H \pm 0.005H
HEQP Width	34 Clocks	2.375	3.74	2.3 \pm 0.1
HSERR Width	68 Clocks	4.749	7.47	4.7 \pm 0.1
HPER iod	910 Clocks	63.556	100	

RS170 Vertical Data

VFP	3 Lines	190.67		6 EQP Pulses
VSYNC Width	3 Lines	190.67		6 Serration Pulses
VBLANK Width	20 Lines	1271.12	7.62	0.075V \pm 0.005V
VDRIVE Width	11.0 Lines	699.12	4.20	0.04V \pm 0.006V
VEQP Intrvl	9 Lines		3.63	9 Lines/Field
VPERiod (field)	262.5 Lines	16.683 ms		16.683 ms/Field
VPERiod (frame)	525 Lines	33.367 ms		33.367 ms/Frame

Absolute Maximum Ratings (Note 1)		Junction Temperature (T_J)	
Supply Voltage (V_{CC})	-0.5V to +7.0V	PDIP	140°C
DC Input Diode Current (I_{IK})		Recommended Operating Conditions	
$V_I = -0.5V$	-20 mA	Supply Voltage (V_{CC})	4.5V to 5.5V
$V_I = V_{CC} + 0.5V$	+20 mA	Input Voltage (V_I)	0V to V_{CC}
DC Input Voltage (V_I)	-0.5V to $V_{CC} + 0.5V$	Output Voltage (V_O)	0V to V_{CC}
DC Output Diode Current (I_{OK})		Operating Temperature (T_A)	-40°C to +85°C
$V_O = -0.5V$	-20 mA	Minimum Input Edge Rate ($\Delta V/\Delta t$)	
$V_O = V_{CC} + 0.5V$	+20 mA	V_{IN} from 0.8V to 2.0V	
DC Output Voltage (V_O)	-0.5V to $V_{CC} + 0.5V$	V_{CC} @ 4.5V, 5.5V	125 mV/ns
DC Output Source		Note 1: Absolute maximum ratings are those values beyond which damage to the device may occur. The databook specifications should be met, without exception, to ensure that the system design is reliable over its power supply, temperature and output/input loading variables. Fairchild does not recommend operation of FACT™ circuits outside databook specifications.	
or Sink Current (I_O)	± 15 mA		
DC V_{CC} or Ground Current			
per Output Pin (I_{CC} or I_{GND})	± 20 mA		
Storage Temperature (T_{STG})	-65°C to +150°C		

DC Electrical Characteristics

For ACT Family Devices over Operating Temperature Range (unless otherwise specified)

Symbol	Parameter	V_{CC} (V)	$T_A = +25^\circ\text{C}$		$T_A = -40^\circ\text{C to } +85^\circ\text{C}$	Units	Conditions	
			$C_L = 50$ pF					
			Typ	Guaranteed Limits				
V_{IH}	Minimum HIGH Level Input Voltage	4.5	1.5	2.0	2.0	V	$V_{OUT} = 0.1V$ or $V_{CC} - 0.1V$	
		5.5	1.5	2.0	2.0			
V_{IL}	Maximum LOW Level Input Voltage	4.5	1.5	0.8	0.8	V	$V_{OUT} = 0.1V$ or $V_{CC} - 0.1V$	
		5.5	1.5	0.8	0.8			
V_{OH}	Minimum HIGH Level Output Voltage	4.5	4.49	4.4	4.4	V	$I_{OUT} = -50 \mu\text{A}$	
		5.5	5.49	5.4	5.4	V		
		4.5		3.86	3.76	V		$V_{IN} = V_{IL}/V_{IH}$ $I_{OH} = -8 \text{ mA}$ (Note 2)
		5.5		4.86	4.76	V		
V_{OL}	Maximum LOW Level Output Voltage	4.5	0.001	0.1	0.1	V	$I_{OUT} = 50 \mu\text{A}$	
		5.5	0.001	0.1	0.1	V		
		4.5		0.36	0.44	V		$V_{IN} = V_{IL}/V_{IH}$ $I_{OH} = +8 \text{ mA}$ (Note 2)
		5.5		0.36	0.44	V		
I_{OLD}	Minimum Dynamic Output Current	5.5			32.0	mA	$V_{OLD} = 1.65V$	
I_{OHD}	Minimum Dynamic Output Current	5.5			-32.0	mA	$V_{OHD} = 3.85V$	
I_{IN}	Maximum Input Leakage Current	5.5		± 0.1	± 1.0	μA	$V_I = V_{CC}, \text{GND}$	
I_{CC}	Supply Current Quiescent	5.5		8.0	80	μA	$V_{IN} = V_{CC}, \text{GND}$	
I_{CCT}	Maximum I_{CC}/Input	5.5	0.6		1.5	mA	$V_{IN} = V_{CC} - 2.1V$	

Note 2: All outputs loaded; thresholds on input associated with input under test.

Note 3: Test Load 50 pF, 500 Ω to Ground.

AC Electrical Characteristics

Symbol	Parameter	V _{CC} (V)	T _A = +25°C C _L = 50 pF			T _A = -40°C to +85°C C _L = 50 pF		Units
			Min	Typ	Max	Min	Max	
t _{MAX1}	Interlaced f _{max} (HMAX/2 is ODD)	5.0	170	190		150		MHz
f _{max}	Non-Interlaced f _{max} (HMAX/2 is EVEN)	5.0	190	220		175		MHz
t _{PLH1} t _{PHL1}	Clock to Any Output	5.0	4.0	13.0	15.5	3.5	18.5	ns
t _{PLH2} t _{PHL2}	Clock to ODDEVEN (Scan Mode)	5.0	4.5	15.0	17.0	3.5	20.5	ns
t _{PLH3}	Load to Outputs	5.0	4.0	11.5	16.0	3.0	19.5	ns

AC Operating Requirements

Symbol	Parameter	V _{CC} (V)	T _A = +25°C		T _A = -40°C to +85°C		Units
			Typ	Guaranteed Minimums			
t _{sc}	Control Setup Time ADDR/DATA to LOAD-	5.0	3.0	4.0	4.5		ns
t _{sc}	L/HBYTE to LOAD-		3.0	4.0	4.5		ns
t _{sd}	Data Setup Time D7-D0 to LOAD+	5.0	2.0	4.0	4.5		ns
t _{hc}	Control Hold Time LOAD- to ADDR/DATA LOAD- to L/HBYTE	5.0	0 0	1.0 1.0	1.0 1.0		ns ns
t _{hd}	Data Hold Time LOAD+ to D7-D0	5.0	1.0	2.0	2.0		ns
t _{rec}	LOAD+ to CLK (Note 4)	5.0	5.5	7.0	8.0		ns
t _{wld-} t _{wld+}	Load Pulse Width LOW HIGH	5.0 5.0	3.0 3.0	5.5 5.0	5.5 7.5		ns ns
t _{wclr}	CLR Pulse Width HIGH	5.0	5.5	6.5	9.5		ns
t _{wck}	CLOCK Pulse Width (HIGH or LOW)	5.0	2.5	3.0	3.5		ns

Note 4: Removal of Vectored Reset or Restart to Clock.

Capacitance

Symbol	Parameter	Typ	Units	Conditions
C _{IN}	Input Capacitance	7.0	pF	V _{CC} = 5.0V
C _{PD}	Power Dissipation Capacitance	17.0	pF	V _{CC} = 5.0V

Capacitance (Continued)

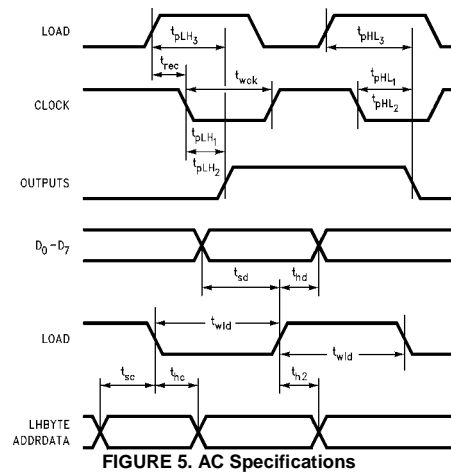

FIGURE 5. AC Specifications

Additional Applications Information

POWERING UP

The ACT715 default value for Bit 10 of the Status Register is 0. This means that when the CLEAR pulse is applied and the registers are initialized by loading the default values the CLOCK is disabled. Before operation can begin, Bit 10 must be changed to a 1 to enable CLOCK. If the default values are needed (no other programming is required) then Figure 6 illustrates a hardwired solution to facilitate the enabling of the CLOCK after power-up. Should control signals be difficult to obtain, Figure 7 illustrates a possible solution to automatically enable the CLOCK upon power-up. Use of the ACT715-R eliminates the need for most of this circuitry. Modifications of the Figure 7 circuit can be made to obtain the lone CLEAR pulse still needed upon power-up.

Note that, although during a Vectored Restart none of the preprogrammed registers are affected, some signals are affected for the duration of one frame only. These signals are the Horizontal and Vertical Drive signals. After a Vectored Restart the beginning of these signals will occur at the first CLK. The end of the signals will occur as programmed. At the completion of the first frame, the signals will resume to their programmed start and end time.

PREPROGRAMMING "ON-THE-FLY"

Although the ACT715 and ACT715-R are completely programmable, certain limitations must be set as to when and how the parts can be reprogrammed. Care must be taken when reprogramming any End Time registers to a new value that is lower than the current value. Should the reprogramming occur when the counters are at a count after the new value but before the old value, then the counters will continue to count up to 4096 before rolling over.

For this reason one of the following two precautions are recommended when reprogramming "on-the-fly". The first recommendation is to reprogram horizontal values during the horizontal blank interval only and/or vertical values during the vertical blank interval only. Since this would require delicate timing requirements the second recommendation may be more appropriate.

The second recommendation is to program a Vectored Restart as the final step of reprogramming. This will ensure that all registers are set to the newly programmed values and that all counters restart at the first CLK position. This will avoid overrunning the counter end times and will maintain the video integrity.

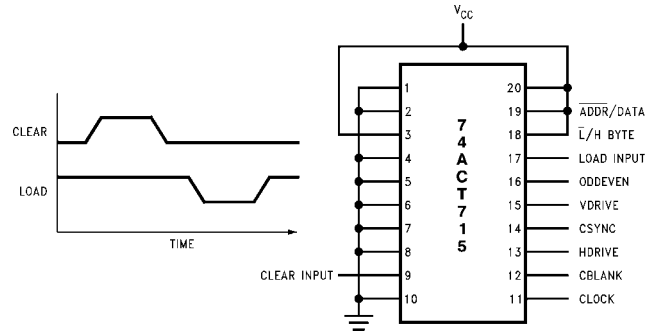
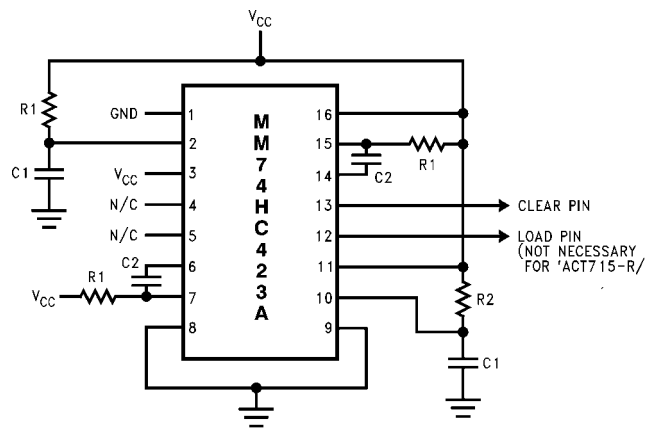

FIGURE 6. Default RS170 Hardware Configuration



Note: A 74HC221A may be substituted for the 74HC423A Pin 6 and Pin 14 must be hardwired to GND

Components

- R1: 4.7k C1: 10 μ F
- R2: 10k C2: 50 pF

FIGURE 7. Circuit for Clear and Load Pulse Generation

Physical Dimensions inches (millimeters) unless otherwise noted

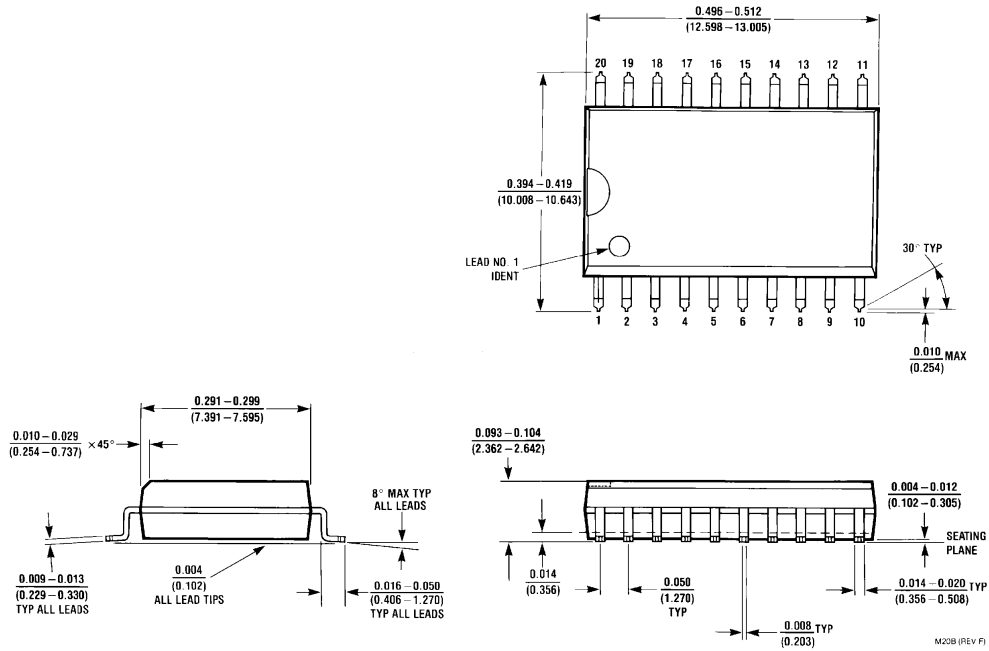

**20-Lead Small Outline Integrated Circuit (SOIC), JEDEC MS-013, 0.300" Wide Body
Package Number M20B**

Physical Dimensions inches (millimeters) unless otherwise noted (Continued)

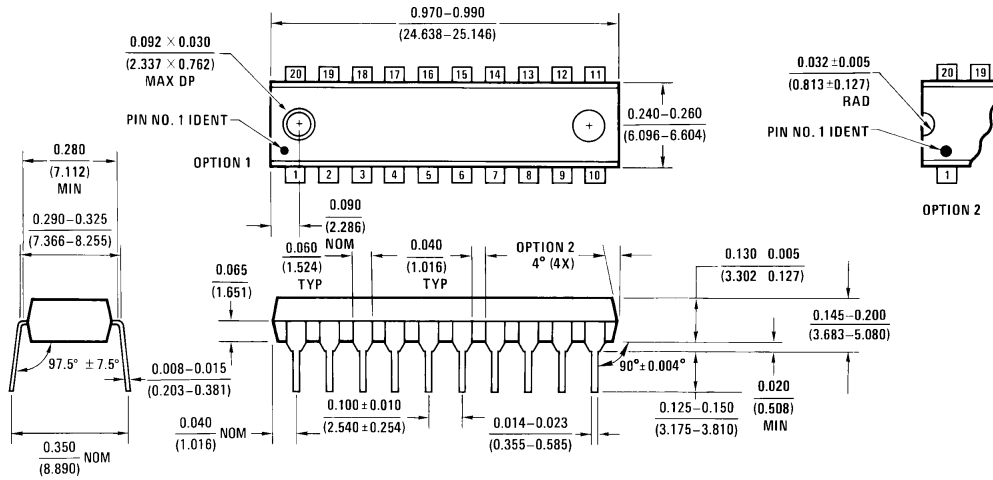

20-Lead Small Outline Integrated Circuit (SOIC), JEDEC MS-120, 0.150" Narrow Body
Package Number N20A

N20B (REV A)

LIFE SUPPORT POLICY

FAIRCHILD'S PRODUCTS ARE NOT AUTHORIZED FOR USE AS CRITICAL COMPONENTS IN LIFE SUPPORT DEVICES OR SYSTEMS WITHOUT THE EXPRESS WRITTEN APPROVAL OF THE PRESIDENT OF FAIRCHILD SEMICONDUCTOR CORPORATION. As used herein:

1. Life support devices or systems are devices or systems which, (a) are intended for surgical implant into the body, or (b) support or sustain life, and (c) whose failure to perform when properly used in accordance with instructions for use provided in the labeling, can be reasonably expected to result in a significant injury to the user.
2. A critical component in any component of a life support device or system whose failure to perform can be reasonably expected to cause the failure of the life support device or system, or to affect its safety or effectiveness.

www.fairchildsemi.com