

## 32-Segment CMOS LCD Driver

### FEATURES

- Drives up to 32 LCD segments of arbitrary configuration
- CMOS process for: wide supply voltage range, low-power operation, high-noise immunity, wide temperature range
- CMOS and TTL-compatible inputs
- Electrostatic discharge protection on all pins
- Cascadable
- On-chip oscillator
- Requires only three control lines

### APPLICATIONS

- Industrial displays
- Consumer product displays
- Telecom product displays
- Automotive dashboard displays

### DESCRIPTION

The AY0438 is a CMOS integrated device that drives a liquid crystal display, usually under microprocessor control. The part acts as a smart peripheral that drives up to 32 LCD segments. It needs only three control lines due to its serial input construction. It latches the data to be displayed and relieves the microprocessor from the task of generating the required waveforms.

The AY0438 can drive any standard or custom parallel drive LCD display, whether it be field effect or dynamic scattering; 7-, 9-, 14- or 16-segment characters; decimals; leading + or -; or special symbols. Several AY0438 devices can be cascaded. The AC frequency of the LCD waveforms can either be supplied by the user or generated by attaching a capacitor to the LCD input, which controls the frequency of an internal oscillator.

The AY0438 is available in 40-lead dual in-line plastic and 44-lead PLCC packages. Unpackaged dice are also available.

### PIN CONFIGURATION

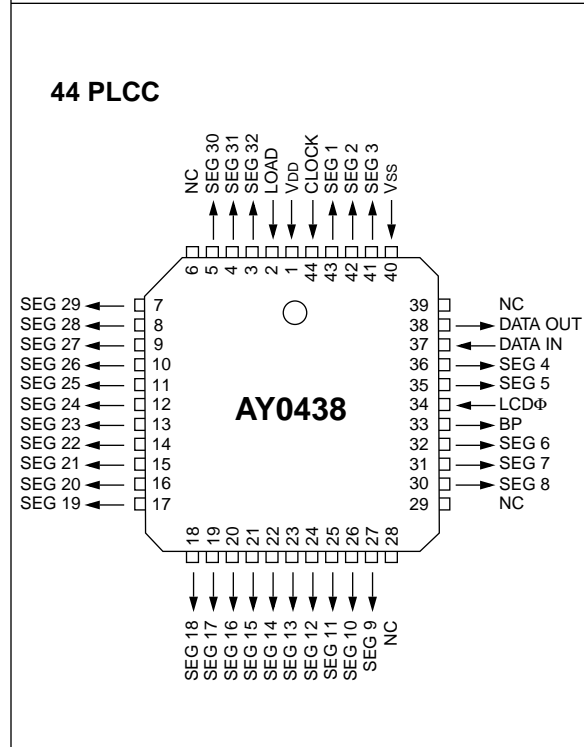
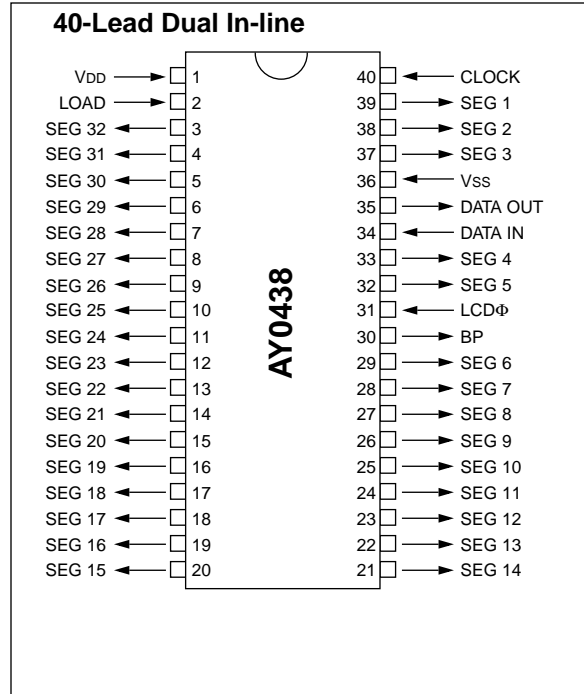

**FIGURE 1: PIN DESCRIPTIONS**

Pin # (PDIP Only)	Name	Direction	Description
1	VDD	-	Supply voltage
2	Load	Input	Latch data from registers
3-29, 32, 33, 37-39	Seg 1-32	Output	Direct drive outputs
30	BP	Output	Backplane drive output
31	LCDΦ	Input	Backplane drive input
34	Data In	Input	Data input to shift register
35	Data Out	Output	Data output from shift register
36	VSS	Ground	Ground
40	Clock	Input	System clock input

**FIGURE 2: BLOCK DIAGRAM**



**FIGURE 3: BACKPLANE AND SEGMENT OUTPUT**

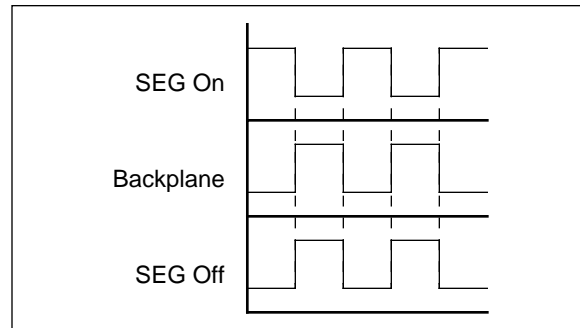

**FIGURE 4: TIMING DIAGRAM**

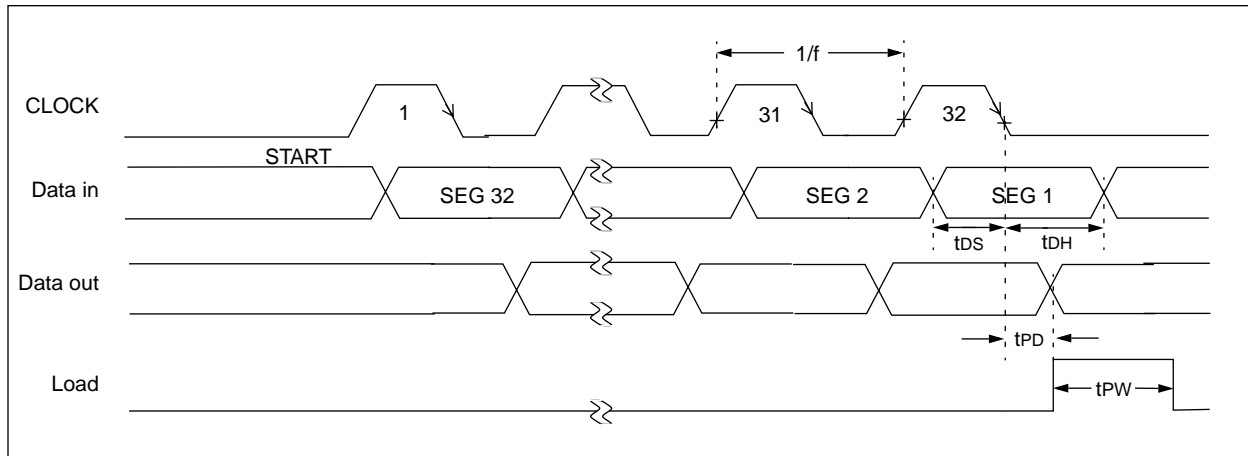

## 1.0 OPERATION:

### 1.1 Data In and Clock

The shift register shifts and outputs on the falling edge of the clock. Every clock falling edge does a logical left shift. As an example, if 32 clock pulses are supplied as in Figure 4, then the data input at the first clock will output at SEG 32, and the last data input (# 32) will output at SEG 1 when a LOAD signal is enabled (Figure 2). It is recommended that a complete 32 bit transfer be done every time the outputs are updated. A logic 1 at the Data In causes the corresponding segment to be

enabled or visible, i.e. the output at Segment Output is 180° out-of-phase with the Backplane output (Figure 3).

### 1.2 Load

A logic 1 at the Load input (Figure 2) causes the parallel load of the data in the shift register into the latches that control the segment drivers. If the Load signal is tied high, then the latches become transparent and the segment drivers are always connected to the shift registers.

## 1.3 LCD $\phi$

LCD $\phi$  can be driven by an external signal or by connecting a capacitor between LCD $\phi$  and ground (GND), which will enable the on-chip oscillator required to generate the backplane output voltage. Figure 5 shows the relationship between capacitance value and output frequency. Leaving the LCD $\phi$  input unconnected is not recommended. When driven by an external clock, the backplane output is in phase with the input clock. When cascading two AY0438 devices (Figure 6 and Figure 7), the backplane output can be generated using a capacitor to GND on the first AY0438. This backplane output can then be connected to the LCD $\phi$  input of the second AY0438. The backplane output of the second device is then used to drive the backplane of the LCD module.

**FIGURE 5: OSCILLATOR FREQUENCY GRAPH (TYPICAL @ 25°C)**

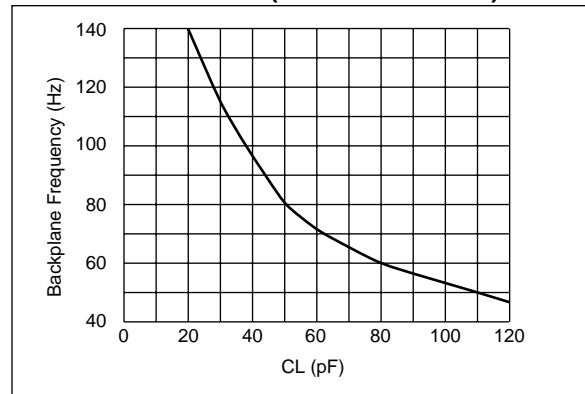

**FIGURE 6: CASCADING TWO AY0438 DEVICES**



**FIGURE 7: CASCADE TIMING DIAGRAM**



# AY0438

## 1.4 General

In order to avoid any race conditions, the Data In and Load signals should not be changed during a falling edge of the Clock. Figure 4 and Figure 7 show a typical timing diagram for a 32 segment and 64 segment LCD module.

## 1.5 Interfacing to a LCD Module and PIC16CXX Device

Figure 8 shows a typical layout of an AY0438 connected to a LCD module and interfaced to a PIC16CXX family device. Example 1 lists code used to program the PIC16CXX device. This code was compiled using MPASM.

**FIGURE 8: INTERFACING TO A LCD MODULE AND PIC16CXX DEVICE**

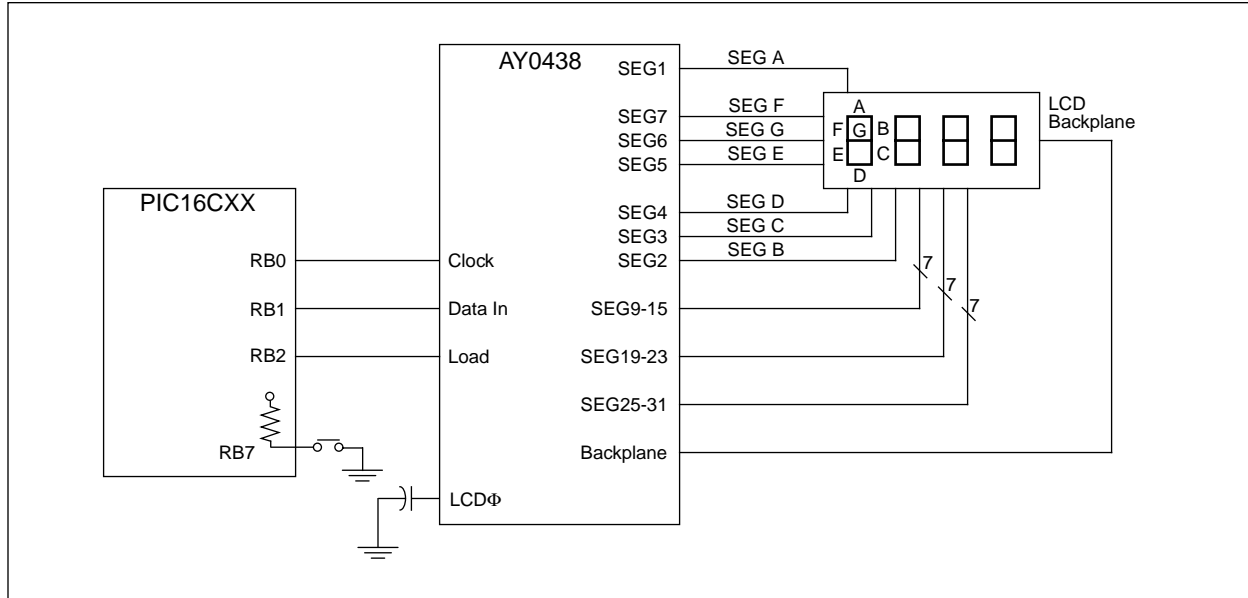

### EXAMPLE 1: EXAMPLE CODE

```

;*****
;This program shows an interface between a PIC16CXX device
;and the AY0438 LCD controller to control a 7 Segment
;4 digit LCD module.
;The PIC16CXX interface to the AY0438 Hardware:
;
;   PORTB bit 0 --> CLK
;   PORTB bit 1 --> DATA IN
;   PORTB bit 2 --> LOAD
;
;The LCD module is connected to the AY0438 as follows:
;   Most Significant digit --> seg1 to seg7
;   3rd Significant digit  --> seg9 to seg15
;   2nd Significant digit   --> seg17 to seg 23
;   Least Significant digit --> seg25 to seg 31
;

```

```

;The DP are not connected, but can be connected to seg8, 16, 24 & 32.
;For each digit, the segments are connected as:
;   Seg A --> seg(8*n + 1)
;   Seg B --> seg(8*n + 2)
;   Seg C --> seg(8*n + 3)
;   Seg D --> seg(8*n + 4)
;   Seg E --> seg(8*n + 5)
;   Seg F --> seg(8*n + 6)
;   Seg G --> seg(8*n + 7)
;where n = 0, 1, 2 and 3 for MSD, 3rdSD, 2ndSD and LSD respectively.
;The firmware uses the values in registers:
;   MSD, THRDSD, SCNDSD and LSD   to determine the values to be
;pulsed to the AY0438.
;In this example, a pushbutton connected to PORTB bit 7
;is checked periodically to see if it has been pressed. If so,
;the LCD values in locations MSD to LSD are updated.
;*****
;           list p=16c71,f=inhx8m
;
;
MSD      equ      0x20
THRDSD   equ      0x21
SCNDSD   equ      0x22
LSD      equ      0x23
count    equ      0x24
temp     equ      0x25
PORTB    equ      0x06
#define CLK      PORTB,0
#define DATAIN PORTB,1
#define LOAD     PORTB,2
#define UPDATELCD PORTB,7
w        equ      0
STATUS   equ      0x03
C        equ      0
RP0      equ      5
OPTION   equ      0x81
RBPU     equ      7
PCL      equ      0x02
PCLATH   equ      0x0A
;
;
;           org      0
;           goto    start
;           org      0x10
;
;This DecodeValue table must reside in page 0 for this program to work
;
DecodeValue
    addwf    PCL
    retlw   B'00111111'    ;decode for 0
    retlw   B'00000110'    ;decode for 1
    retlw   B'01011011'    ;decode for 2
    retlw   B'01001111'    ;decode for 3
    retlw   B'01100110'    ;decode for 4
    retlw   B'01101101'    ;decode for 5

```

# AY0438

```
        retlw  B'01111101'    ;decode for 6
        retlw  B'00000111'    ;decode for 7
        retlw  B'01111111'    ;decode for 8
        retlw  B'01101111'    ;decode for 9
;
;
start
        clrf   PORTB
        bsf   STATUS,RP0      ;set portb 0,1&2 as outputs
        movlw B'11111000'    ;
        movwf PORTB          ;
        bcf   OPTION,RBPU    ;enable pull-up for switch
        bcf   STATUS,RP0
wait
        btfsc UPDATELCD      ;see if update switch is low
        goto  wait           ;no then wait
        bcf   LOAD           ;make sure load is disabled
        movf  LSD,w          ;get least significant value
        clrf  PCLATH         ;PCH = 0
        call  DecodeValue    ;decode the value
        call  Send8          ;serially output the seg values
        movf  SCNDS,w        ;get 2nd significant digit
        call  DecodeValue    ;decode it
        call  Send8          ;serially output it
        movf  THRDSD,w       ;get 3rd significant digit
        call  DecodeValue    ;decode it
        call  Send8
        movf  MSD,w          ;get Most significant value
        call  DecodeValue    ;decode it
        call  Send8          ;serially send it
        bsf   LOAD           ;toggle the LOAD line
        bcf   LOAD           ;to enable the latches
KeyReleased
        btfss UPDATELCD      ;wait for key to be released
        goto  KeyReleased
        goto  wait           ;repeat loop.
;
;Send8, sends the 8 bits in the W register
Send8
        movwf temp           ;save in temp
        movlw .8             ;init count
        movwf count         ;to 8
sendloop
        bcf   DATAIN        ;make sure DATAIN is low
        rrf   temp            ;rotate value through carry
        btfsc STATUS,C       ;if bit clear then skip
        bsf   DATAIN        ;else set data bit
        bsf   CLK             ;toggle clock
        bcf   CLK             ;
        decfsz count         ;see if 8 done
        goto  sendloop       ;no then do all
        return                ;else return

        end
```

## 2.0 ELECTRICAL CHARACTERISTICS

### Maximum Ratings\*

VDD.....	-0.3V to +12V
Inputs (CLK, Data In, Load) .....	VCC to VDD +0.3V
LCDΦ Input .....	-0.3V to VDD +0.3V
Power Dissipation.....	250 mW
Storage Temperature.....	-65°C to +125°C
Operating Temperature Industrial.....	-40°C to +85°C

\* Exceeding these ratings could cause permanent damage to the device. This is a stress rating only and functional operation of this device at these conditions is not implied. Operating ranges are specified in Standard Conditions. Exposure to absolute maximum rating conditions for extended periods may affect device reliability.

Data labeled "typical" is presented for design guidance only and is not guaranteed.

**TABLE 2: DC CHARACTERISTICS**

VDD = +5V unless otherwise noted, TA = 40°C to +85°C						
Characteristics	Sym	Min	Typ	Max	Units	Conditions
Supply Voltage	VDD	+3.0	—	+8.5	V	
Supply Current	IDD	—	25	60	μA	LCDΦ OSC < 15 kHz
		—	13	30	μA	LCDΦ OSC < 100 Hz
Input High Level	VIH	0.5 VDD	—	VDD	V	
Input Low Level	VIH1	0	—	0.1 VDD	V	3.0V ≤ VDD ≤ 8.5V
	VIH2	0	—	0.1 VDD	V	3.0V ≤ VDD ≤ 8.5V
Input Leakage Current	IL	—	0.01	±10	μA	VIN = 0V and +5.0V
Input Capacitance	CI	—	—	5.0	pF	VDD = +5.0V
Segment Output Voltage	VOH	0.8 VDD	—	VDD	V	IOH = -100 μA
	VOL	0	—	0.1 VDD	V	IOH = 100 μA
LCDΦ Input High Level	VIN	0.9 VDD	—	VDD	V	
LCDΦ Input Low Level	VIL	0	—	0.1 VDD	V	
LCDΦ Input Leakage	IL	—	—	10	μA	VIN = 0V and +5.0V VDD = +5.0V

**TABLE 3: AC CHARACTERISTICS**

Characteristics	Sym	Min	Typ	Max	Units	Conditions
Clock Rate	f	DC	—	1.5	MHz	50% duty cycle
Data Set-up Time	tDS	150	—	—	nsec	Data change to Clk falling edge
Data Hold Time	tDH	50	—	—	nsec	
Load Pulse Width	tPW	175	—	—	nsec	
Data Out Prop. Delay	tPD	—	—	500	nsec	CL = 55 pF

NOTES:



# AY0438

## AY0438 Product Identification System

To order or to obtain information, e.g., on pricing or delivery, please use the listed part numbers, and refer to the factory or the listed sales offices.

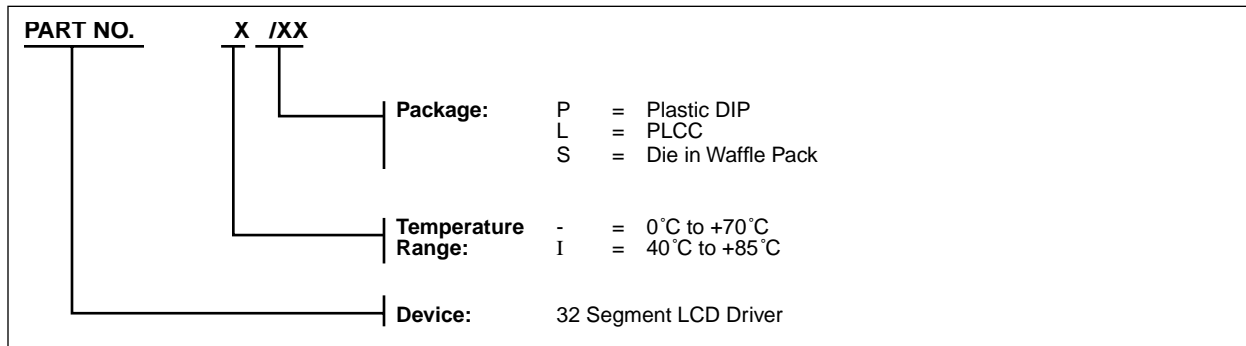

## Sales and Support

Products supported by a preliminary Data Sheet may possibly have an errata sheet describing minor operational differences and recommended workarounds. To determine if an errata sheet exists for a particular device, please contact one of the following:

1. Your local Microchip sales office.
2. The Microchip Corporate Literature Center U.S. FAX: (602) 786-7277
3. The Microchip's Bulletin Board, via your local CompuServe number (CompuServe membership NOT required).

Please specify which device, revision of silicon and Data Sheet (include Literature #) you are using.

For latest version information and upgrade kits for Microchip Development Tools, please call 1-800-755-2345 or 1-602-786-7302.

---

---

**Note the following details of the code protection feature on PICmicro® MCUs.**

- The PICmicro family meets the specifications contained in the Microchip Data Sheet.
- Microchip believes that its family of PICmicro microcontrollers is one of the most secure products of its kind on the market today, when used in the intended manner and under normal conditions.
- There are dishonest and possibly illegal methods used to breach the code protection feature. All of these methods, to our knowledge, require using the PICmicro microcontroller in a manner outside the operating specifications contained in the data sheet. The person doing so may be engaged in theft of intellectual property.
- Microchip is willing to work with the customer who is concerned about the integrity of their code.
- Neither Microchip nor any other semiconductor manufacturer can guarantee the security of their code. Code protection does not mean that we are guaranteeing the product as “unbreakable”.
- Code protection is constantly evolving. We at Microchip are committed to continuously improving the code protection features of our product.

If you have any further questions about this matter, please contact the local sales office nearest to you.

---

Information contained in this publication regarding device applications and the like is intended through suggestion only and may be superseded by updates. It is your responsibility to ensure that your application meets with your specifications. No representation or warranty is given and no liability is assumed by Microchip Technology Incorporated with respect to the accuracy or use of such information, or infringement of patents or other intellectual property rights arising from such use or otherwise. Use of Microchip's products as critical components in life support systems is not authorized except with express written approval by Microchip. No licenses are conveyed, implicitly or otherwise, under any intellectual property rights.

#### **Trademarks**

The Microchip name and logo, the Microchip logo, FilterLab, KEELOQ, microID, MPLAB, PIC, PICmicro, PICMASTER, PICSTART, PRO MATE, SEEVAL and The Embedded Control Solutions Company are registered trademarks of Microchip Technology Incorporated in the U.S.A. and other countries.

dsPIC, ECONOMONITOR, FanSense, FlexROM, fuzzyLAB, In-Circuit Serial Programming, ICSP, ICEPIC, microPort, Migratable Memory, MPASM, MPLIB, MPLINK, MPSIM, MXDEV, PICC, PICDEM, PICDEM.net, rPIC, Select Mode and Total Endurance are trademarks of Microchip Technology Incorporated in the U.S.A.

Serialized Quick Turn Programming (SQTP) is a service mark of Microchip Technology Incorporated in the U.S.A.

All other trademarks mentioned herein are property of their respective companies.

© 2002, Microchip Technology Incorporated, Printed in the U.S.A., All Rights Reserved.

 Printed on recycled paper.

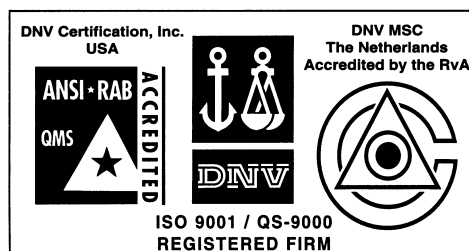

*Microchip received QS-9000 quality system certification for its worldwide headquarters, design and wafer fabrication facilities in Chandler and Tempe, Arizona in July 1999. The Company's quality system processes and procedures are QS-9000 compliant for its PICmicro® 8-bit MCUs, KEELOQ® code hopping devices, Serial EEPROMs and microperipheral products. In addition, Microchip's quality system for the design and manufacture of development systems is ISO 9001 certified.*



# MICROCHIP

## WORLDWIDE SALES AND SERVICE

### AMERICAS

#### Corporate Office

2355 West Chandler Blvd.  
Chandler, AZ 85224-6199  
Tel: 480-792-7200 Fax: 480-792-7277  
Technical Support: 480-792-7627  
Web Address: <http://www.microchip.com>

#### Rocky Mountain

2355 West Chandler Blvd.  
Chandler, AZ 85224-6199  
Tel: 480-792-7966 Fax: 480-792-7456

#### Atlanta

500 Sugar Mill Road, Suite 200B  
Atlanta, GA 30350  
Tel: 770-640-0034 Fax: 770-640-0307

#### Boston

2 Lan Drive, Suite 120  
Westford, MA 01886  
Tel: 978-692-3848 Fax: 978-692-3821

#### Chicago

333 Pierce Road, Suite 180  
Itasca, IL 60143  
Tel: 630-285-0071 Fax: 630-285-0075

#### Dallas

4570 Westgrove Drive, Suite 160  
Addison, TX 75001  
Tel: 972-818-7423 Fax: 972-818-2924

#### Detroit

Tri-Atria Office Building  
32255 Northwestern Highway, Suite 190  
Farmington Hills, MI 48334  
Tel: 248-538-2250 Fax: 248-538-2260

#### Kokomo

2767 S. Albright Road  
Kokomo, Indiana 46902  
Tel: 765-864-8360 Fax: 765-864-8387

#### Los Angeles

18201 Von Karman, Suite 1090  
Irvine, CA 92612  
Tel: 949-263-1888 Fax: 949-263-1338

#### New York

150 Motor Parkway, Suite 202  
Hauppauge, NY 11788  
Tel: 631-273-5305 Fax: 631-273-5335

#### San Jose

Microchip Technology Inc.  
2107 North First Street, Suite 590  
San Jose, CA 95131  
Tel: 408-436-7950 Fax: 408-436-7955

#### Toronto

6285 Northam Drive, Suite 108  
Mississauga, Ontario L4V 1X5, Canada  
Tel: 905-673-0699 Fax: 905-673-6509

### ASIA/PACIFIC

#### Australia

Microchip Technology Australia Pty Ltd  
Suite 22, 41 Rawson Street  
Epping 2121, NSW  
Australia  
Tel: 61-2-9868-6733 Fax: 61-2-9868-6755

#### China - Beijing

Microchip Technology Consulting (Shanghai)  
Co., Ltd., Beijing Liaison Office  
Unit 915  
Bei Hai Wan Tai Bldg.  
No. 6 Chaoyangmen Beidajie  
Beijing, 100027, No. China  
Tel: 86-10-85282100 Fax: 86-10-85282104

#### China - Chengdu

Microchip Technology Consulting (Shanghai)  
Co., Ltd., Chengdu Liaison Office  
Rm. 2401, 24th Floor,  
Ming Xing Financial Tower  
No. 88 TIDU Street  
Chengdu 610016, China  
Tel: 86-28-6766200 Fax: 86-28-6766599

#### China - Fuzhou

Microchip Technology Consulting (Shanghai)  
Co., Ltd., Fuzhou Liaison Office  
Unit 28F, World Trade Plaza  
No. 71 Wusi Road  
Fuzhou 350001, China  
Tel: 86-591-7503506 Fax: 86-591-7503521

#### China - Shanghai

Microchip Technology Consulting (Shanghai)  
Co., Ltd.  
Room 701, Bldg. B  
Far East International Plaza  
No. 317 Xian Xia Road  
Shanghai, 200051  
Tel: 86-21-6275-5700 Fax: 86-21-6275-5060

#### China - Shenzhen

Microchip Technology Consulting (Shanghai)  
Co., Ltd., Shenzhen Liaison Office  
Rm. 1315, 13/F, Shenzhen Kerry Centre,  
Renminnan Lu  
Shenzhen 518001, China  
Tel: 86-755-2350361 Fax: 86-755-2366086

#### Hong Kong

Microchip Technology Hongkong Ltd.  
Unit 901-6, Tower 2, Metroplaza  
223 Hing Fong Road  
Kwai Fong, N.T., Hong Kong  
Tel: 852-2401-1200 Fax: 852-2401-3431

#### India

Microchip Technology Inc.  
India Liaison Office  
Divyasree Chambers  
1 Floor, Wing A (A3/A4)  
No. 11, O'Shaugnessey Road  
Bangalore, 560 025, India  
Tel: 91-80-2290061 Fax: 91-80-2290062

### Japan

Microchip Technology Japan K.K.  
Benex S-1 6F  
3-18-20, Shinyokohama  
Kohoku-Ku, Yokohama-shi  
Kanagawa, 222-0033, Japan  
Tel: 81-45-471- 6166 Fax: 81-45-471-6122

### Korea

Microchip Technology Korea  
168-1, Youngbo Bldg. 3 Floor  
Samsung-Dong, Kangnam-Ku  
Seoul, Korea 135-882  
Tel: 82-2-554-7200 Fax: 82-2-558-5934

### Singapore

Microchip Technology Singapore Pte Ltd.  
200 Middle Road  
#07-02 Prime Centre  
Singapore, 188980  
Tel: 65-6334-8870 Fax: 65-6334-8850

### Taiwan

Microchip Technology Taiwan  
11F-3, No. 207  
Tung Hua North Road  
Taipei, 105, Taiwan  
Tel: 886-2-2717-7175 Fax: 886-2-2545-0139

### EUROPE

#### Denmark

Microchip Technology Nordic ApS  
Regus Business Centre  
Lautrup høj 1-3  
Ballerup DK-2750 Denmark  
Tel: 45 4420 9895 Fax: 45 4420 9910

#### France

Microchip Technology SARL  
Parc d'Activite du Moulin de Massy  
43 Rue du Saule Trapu  
Batiment A - 1er Etage  
91300 Massy, France  
Tel: 33-1-69-53-63-20 Fax: 33-1-69-30-90-79

#### Germany

Microchip Technology GmbH  
Gustav-Heinemann Ring 125  
D-81739 Munich, Germany  
Tel: 49-89-627-144 0 Fax: 49-89-627-144-44

#### Italy

Microchip Technology SRL  
Centro Direzionale Colleoni  
Palazzo Taurus 1 V. Le Colleoni 1  
20041 Agrate Brianza  
Milan, Italy  
Tel: 39-039-65791-1 Fax: 39-039-6899883

#### United Kingdom

Arizona Microchip Technology Ltd.  
505 Eskdale Road  
Winnersh Triangle  
Wokingham  
Berkshire, England RG41 5TU  
Tel: 44 118 921 5869 Fax: 44-118 921-5820

03/01/02