



32-Channel High Voltage Amplifier Array

Features

- ❑ 32 independent high voltage amplifiers
- ❑ Output voltage up to 250V
- ❑ 3V/μs output slew rate
- ❑ Fixed gain of 50V/V
- ❑ High value internal feedback resistors
- ❑ Very low operating current (typically 45μA per channel)
- ❑ Integrated silicon diode for temperature sensing

Application

- ❑ MEMS (microelectromechanical systems) driver
- ❑ Piezoelectric transducer driver
- ❑ Optical crosspoint switches (using MEMS technology)

General Description

The Supertex HV254 is a 32-channel high voltage amplifier array integrated circuit. It operates on a 275V high voltage supply and two low voltage supplies: +5.0V and -5.0V. Each channel has its own input and output. An integrated diode is included to help monitor die temperature.

The input voltage can be from a dac with a voltage range of 0V to the low voltage supply, V+. The output of the HV254FG will swing from 7V to 250V. It cannot swing to ground. With the internal gain set at 50V/V, a minimum input signal of 140mV will still maintain linearity. Input voltages below 140mV can be applied without damage to the device. The amplifier, however, will be saturated. Typical output load is equivalent to a 125Mohm resistor in parallel with a 100pF capacitor. The outputs have a guaranteed slew rate of at least 3V/μs. The internal closed loop gain is set at a nominal value of 34.0dB (50V/V).

The HV254 is designed to operate with minimal power consumption while maintaining a guaranteed slew rate of 3V/μs. High value resistors are used for the gain setting to minimize current on the feedback path.

Block Diagram

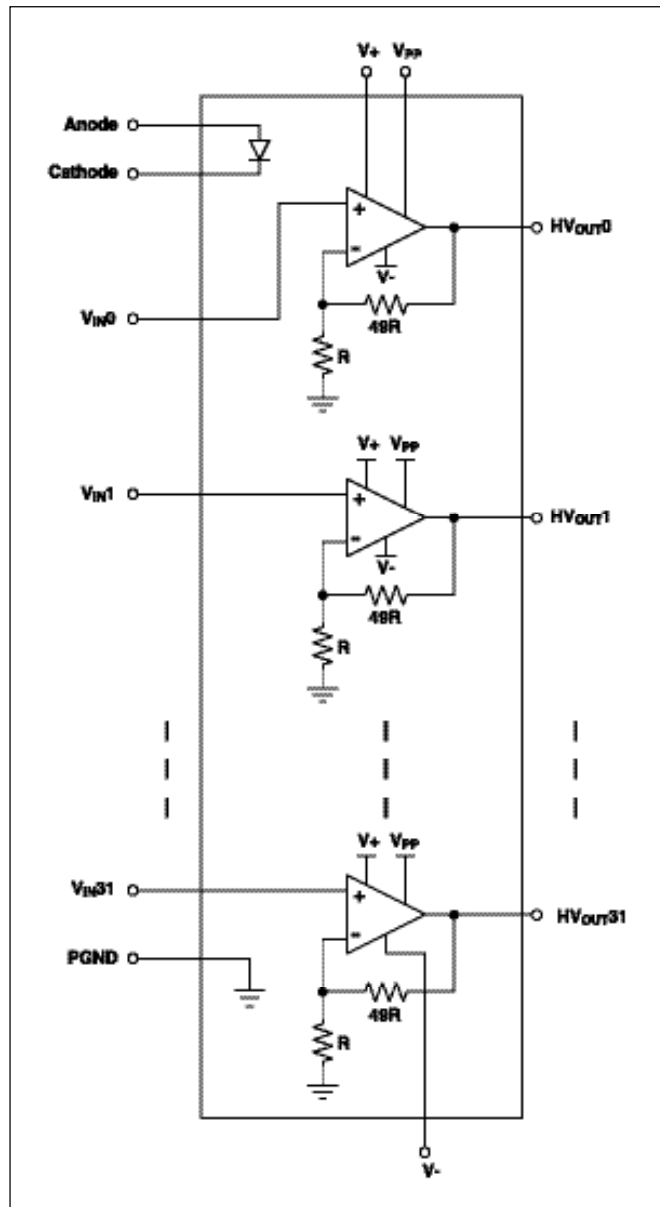

Ordering Information

Device	Maximum Output Voltage	Package Options	
		100 Lead MQFP	Die
HV254	250V	HV254FG	HV254X

Absolute Maximum Ratings*

V_{PP} , High voltage supply	275V
V_+ , Low voltage positive supply	7.0V
V_- , Low voltage negative supply	-7.0V
HV_{OUT} , Output voltage	0V to 275V
V_{IN} , Analog input signal	0V to 5.0V
Storage temperature range	-65°C to 150°C
Maximum junction temperature	150°C

* All voltages are referenced to device ground.

Electrical Characteristics (Over operating conditions unless otherwise noted.)

Symbol	Parameter	Min	Typ	Max	Units	Conditions
--------	-----------	-----	-----	-----	-------	------------

Operating Conditions

V_{PP}	High voltage positive supply	50		275	V	
V_+	Low voltage positive supply	4.75	5.0	5.25	V	
V_-	Low voltage negative supply	-4.75	-5.0	-5.25	V	
I_{PP}	V_{PP} supply current	1.0		2.5	mA	$V_{PP}=275V$, All inputs set at 140mV. Typically 45 μ A per channel
I_+	V_+ supply current			1.0	mA	$V_+ = 5.25V$
I_-	V_{NN} supply current			-3.0	mA	$V_- = -5.25V$
T_A	Ambient temperature range	-10		70	°C	
T_J	Junction temperature range	-10		TBD	°C	

High Voltage Amplifier Output

HV_{OUT}	HV_{OUT} voltage swing	7.0		250	V	$V_{PP} = 275V$, Load=125M Ω //100pF
V_{IN}	Input Voltage Range	0.14		V_+	V	
HV_{OS}	HV_{OUT} DC offset		± 1.5	± 1.52	V	$V_{PP} = 275V$. 30mV input offset
SR	HV_{OUT} slew rate	3.0			V/ μ s	$V_{PP} = 275V$, Load = 125M Ω //100pF
R_{FB}	Feedback impedance	8	12		M Ω	
A_V	Closed loop gain	47.5	50.0	52.5	V/V	
BW	HV_{OUT} -3dB channel bandwidth	5.0			KHz	$V_{PP} = 275V$
C_{LOAD}	HV_{OUT} capacitive load	0		100	pF	
	Stability (max drift)			500	mV	Measured at HV_{OUT}

Diode

Symbol	Parameter	Min	Typ	Max	Units	Conditions
PIV	Peak inverse voltage			5.0	V	cathode to anode
V_F	Forward diode drop			0.8	V	I _f =2.0mA, anode to cathode
I_F	Forward diode current			2.0	mA	anode to cathode
T_C	V_F temperature coefficient		TBD		mV/°C	anode to cathode

Power Up/Down Sequence

The device can be damaged due to improper power up / down sequence. To prevent damage, please follow the acceptable power up /down sequences and add two external diodes as shown in the diagram below. The first diode is a high voltage diode across V_{pp} and V+ where the anode of the diode is connected to V+ and the cathode of the diode is connected to V_{pp}. Any low current high voltage diode such as a 1N4004 will be adequate. The second diode is a schottky diode across V- and DGnd where the anode of the schottky diode is connected to V- and the cathode is connected to DGnd. Any low current schottky diode such as a 1N5817 will be adequate.

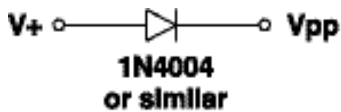

Acceptable Power Up Sequences

- | | | | |
|--------------------|-------|--------------------|-------------------|
| 1) V _{pp} | 2) V- | 3) V+ | 4) Inputs & Anode |
| 1) V+ | 2) V- | 3) V _{pp} | 4) Inputs & Anode |

Acceptable Power Down Sequences

- | | | | |
|-------------------|--------------------|-------|--------------------|
| 1) Inputs & Anode | 2) V _{pp} | 3) V+ | 4) V- |
| 1) Inputs & Anode | 2) V+ | 3) V- | 4) V _{pp} |

Pin Description

V _{pp}	High voltage positive supply.
V+	Analog low voltage positive supply.
V-	Analog low voltage negative supply.
PGND	Device ground.
Anode	Anode side of a low voltage silicon diode that can be used to monitor die temperature.
Cathode	Cathode side of a low voltage silicon diode that can be used to monitor die temperature.
V _{IN} 0 to V _{IN} 31	Amplifier inputs.
HV _{OUT} 0 to HV _{OUT} 31	Amplifier outputs.

Pin Configuration

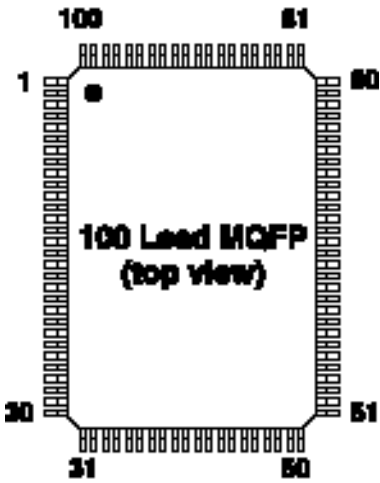

Pin Configuration

Pin #	Function
1	HV _{OUT} 29
2	HV _{OUT} 28
3	HV _{OUT} 27
4	HV _{OUT} 26
5	HV _{OUT} 25
6	HV _{OUT} 24
7	HV _{OUT} 23
8	HV _{OUT} 22
9	HV _{OUT} 21
10	HV _{OUT} 20
11	HV _{OUT} 19
12	HV _{OUT} 18
13	HV _{OUT} 17
14	HV _{OUT} 16
15	HV _{OUT} 15
16	HV _{OUT} 14
17	HV _{OUT} 13
18	HV _{OUT} 12
19	HV _{OUT} 11
20	HV _{OUT} 10
21	HV _{OUT} 9
22	HV _{OUT} 8
23	HV _{OUT} 7
24	HV _{OUT} 6
25	HV _{OUT} 5

Pin #	Function
26	HV _{OUT} 4
27	HV _{OUT} 3
28	HV _{OUT} 2
29	HV _{OUT} 1
30	HV _{OUT} 0
31	NC
32	NC
33	NC
34	NC
35	NC
36	V _{PP}
37	V _{PP}
38	NC
39*	Ibias
40	NC
41	V-
42	V-
43	Anode
44	Cathode
45	V+
46	V+
47	NC
48	PGND
49	V _{IN} 0
50	V _{IN} 1

Pin #	Function
51	V _{IN} 2
52	V _{IN} 3
53	V _{IN} 4
54	V _{IN} 5
55	V _{IN} 6
56	V _{IN} 7
57	V _{IN} 8
58	V _{IN} 9
59	V _{IN} 10
60	V _{IN} 11
61	V _{IN} 12
62	V _{IN} 13
63	V _{IN} 14
64	V _{IN} 15
65	V _{IN} 16
66	V _{IN} 17
67	V _{IN} 18
68	V _{IN} 19
69	V _{IN} 20
70	V _{IN} 21
71	V _{IN} 22
72	V _{IN} 23
73	V _{IN} 24
74	V _{IN} 25
75	V _{IN} 26

Pin #	Function
76	V _{IN} 27
77	V _{IN} 28
78	V _{IN} 29
79	V _{IN} 30
80	V _{IN} 31
81	PGND
82	NC
83	NC
84	NC
85	NC
86	NC
87	NC
88	NC
89	NC
90	NC
91	NC
92	NC
93	NC
94	NC
95	NC
96	NC
97	NC
98	NC
99	HV _{OUT} 31
100	HV _{OUT} 30

* For internal testing only. Leave floating.
 NC=No Connect.

Pad Configuration (Not Drawn to Scale)

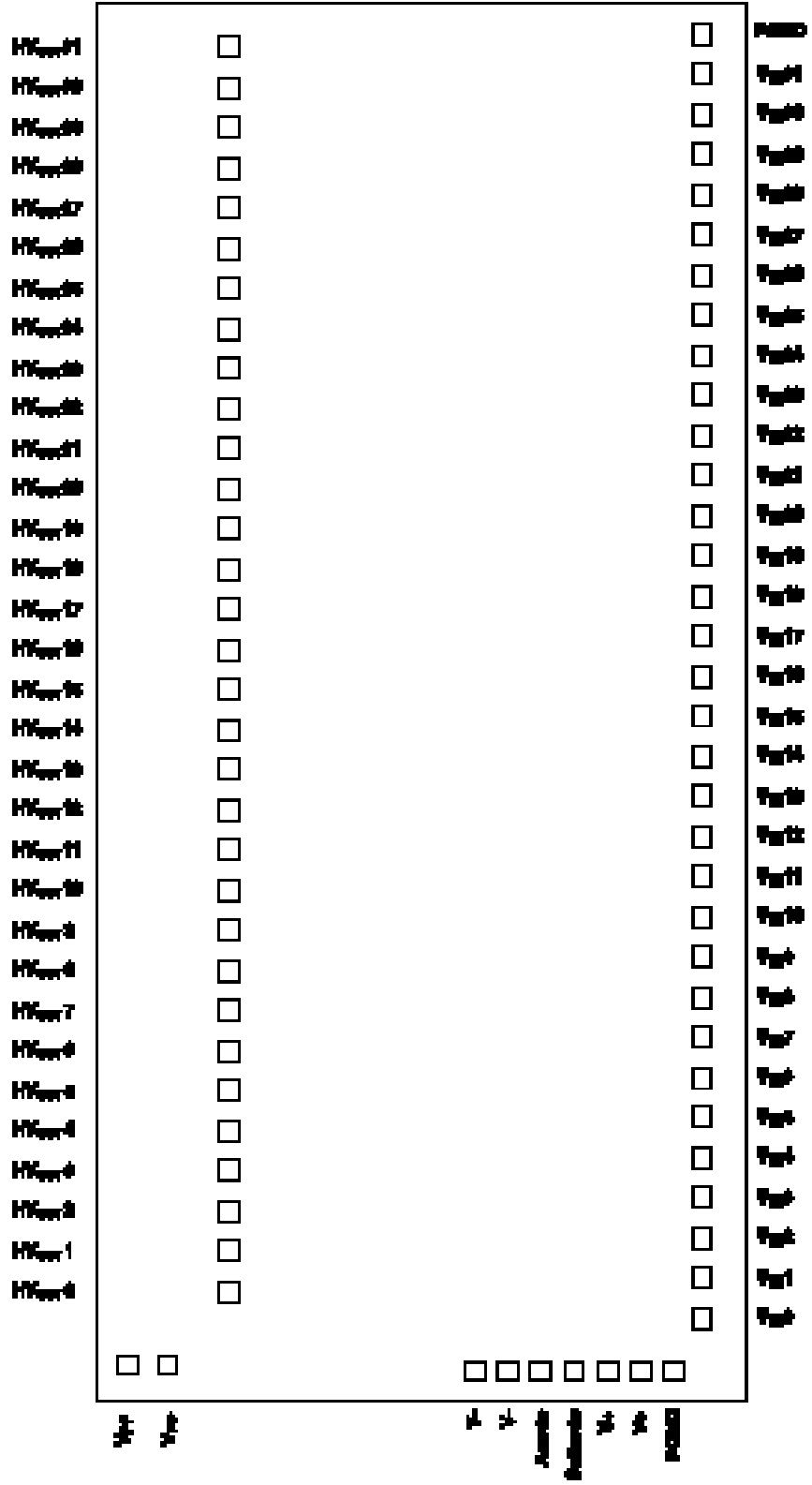

Die Size=4800µm X 11180µm (including scribes)

Center of the die is 0,0.

Coordinates for the four corners of the chip (not including scribe):

X (µm)	Y (µm)
-2402	5492
-2402	-5492
2335	5492
2335	-5492

Notes:

- 1) The two PGND pads are not electrically connected.
- 2) The two V_{PP} pads, V+ pads, and V- pads are electrically connected.
- 3) Backside potential is V_{PP}. Leave floating or connect to V_{PP}.
- 4) Anode and Cathode are connected to the P and N terminals (respectively) of a silicon diode which can be used to measure temperature.

Pad Description:

- V_{PP} High voltage positive supply. Two V_{PP} pads.
- V+ Low voltage positive supply. Two V+ pads.
- V- Low voltage negative supply. Two V- pads.
- V_{IN0} to V_{IN 31} Amplifier inputs.
- HV_{OUT0} to HV_{OUT31} Amplifier outputs.
- PGND Power ground. Two PGND pads. Need to be externally connected together.
- Anode Anode side of diode.
- Cathode Cathode side of diode.

Pad Coordinates

Pad Name	X (µm)	Y (µm)
HV _{OUT31}	-1447.5	5244
HV _{OUT30}	-1447.5	4926.5
HV _{OUT29}	-1447.5	4609
HV _{OUT28}	-1447.5	4291.5
HV _{OUT27}	-1447.5	3974
HV _{OUT26}	-1447.5	3656.5
HV _{OUT25}	-1447.5	3339
HV _{OUT24}	-1447.5	3021.5
HV _{OUT23}	-1447.5	2704
HV _{OUT22}	-1447.5	2386.5
HV _{OUT21}	-1447.5	2069
HV _{OUT20}	-1447.5	1751.5
HV _{OUT19}	-1447.5	1434
HV _{OUT18}	-1447.5	1116.5
HV _{OUT17}	-1447.5	799
HV _{OUT16}	-1447.5	481.5
HV _{OUT15}	-1447.5	164
HV _{OUT14}	-1447.5	-153.5
HV _{OUT13}	-1447.5	-471
HV _{OUT12}	-1447.5	-788.5
HV _{OUT11}	-1447.5	-1106
HV _{OUT10}	-1447.5	-1423.5
HV _{OUT9}	-1447.5	-1741
HV _{OUT8}	-1447.5	-2058.5
HV _{OUT7}	-1447.5	-2376

Pad Name	X (µm)	Y (µm)
HV _{OUT6}	-1447.5	-2693.5
HV _{OUT5}	-1447.5	-3011
HV _{OUT4}	-1447.5	-3328.5
HV _{OUT3}	-1447.5	-3646
HV _{OUT2}	-1447.5	-3963.5
HV _{OUT1}	-1447.5	-4281
HV _{OUT0}	-1447.5	-4598.5
V _{PP}	-2057	-4985
V _{PP}	-1897	-4985
V-	1030.5	-5018
V-	1190.5	-5018
Anode	1350.5	-5018
Cathode	1550.5	-5018
V+	1710.5	-5018
V+	1870.5	-5018
Pgnd	2034.5	-5018
V _{IN0}	2156.5	-4725
V _{IN1}	2156.5	-4411
V _{IN2}	2156.5	-4097
V _{IN3}	2156.5	-3783
V _{IN4}	2156.5	-3469
V _{IN5}	2156.5	-3155
V _{IN6}	2156.5	-2841
V _{IN7}	2156.5	-2527
V _{IN8}	2156.5	-2213

Pad Name	X (µm)	Y (µm)
V _{IN9}	2156.5	-1899
V _{IN10}	2156.5	-1585
V _{IN11}	2156.5	-1271
V _{IN12}	2156.5	-957
V _{IN13}	2156.5	-643
V _{IN14}	2156.5	-329
V _{IN15}	2156.5	-15
V _{IN16}	2156.5	299
V _{IN17}	2156.5	613
V _{IN18}	2156.5	927
V _{IN19}	2156.5	1241
V _{IN20}	2156.5	1555
V _{IN21}	2156.5	1869
V _{IN22}	2156.5	2183
V _{IN23}	2156.5	2497
V _{IN24}	2156.5	2811
V _{IN25}	2156.5	3125
V _{IN26}	2156.5	3439
V _{IN27}	2156.5	3753
V _{IN28}	2156.5	4067
V _{IN29}	2156.5	4381
V _{IN30}	2156.5	4695
V _{IN31}	2156.5	5009
Pgnd	2156.5	5315.5

07/24/03rev.6e



©2003 Supertex Inc. All rights reserved. Unauthorized use or reproduction prohibited.

1235 Bordeaux Drive, Sunnyvale, CA 94089
 TEL: (408) 222-8888 • FAX: (408) 222-4895

www.supertex.com