



High-Speed CMOS 16-Bit Transceivers in QVSOP™

QS74FCT2X245T
QS74FCT2X2245T

FEATURES/BENEFITS

- 16-bit Function compatible to the 74F245, 74ABT245 and 74FCT245T
- CMOS power levels: <15mW static
- Available in 40-pin QVSOP (Q2)
- TTL-compatible input and output levels
- Ground bounce controlled outputs
- Reduced output swing of 0-3.5V
- Undershoot clamp diodes on all inputs

FCT-T 2X245T

- JEDEC-FCT spec compatible
- Fastest CMOS logic family available
- A and C speed grades; 4.1ns t_{PD} for C
- $I_{OL} = 64\text{mA}$

FCT-T 2X2245T

- Built-in 25Ω series resistor outputs reduce reflection and other system noise
- A and C speed grades; 4.1ns t_{PD} for C
- $I_{OL} = 12\text{mA}$

DESCRIPTION

The FCT2X245T and FCT2X2245T are 16-bit non-inverting transceivers with three-state outputs that are useful for bus-oriented applications. The Transmit/Receive (T/R) inputs determine the direction of data flow, whether from A-to-B or B-to-A, and the Output Enable (\overline{OE}) inputs enable the selected port for output. The FCT2X2245T is a 25Ω resistor output version useful for driving transmission lines and reducing system noise. All inputs have clamp diodes for undershoot noise suppression. All outputs have ground bounce suppression (see QSI Application Note AN-001), and outputs will not load an active bus when V_{CC} is removed from the device.

Figure 1. Functional Block Diagram

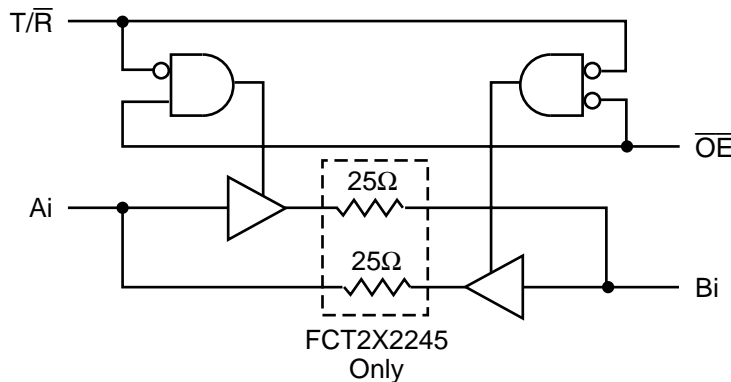

Figure 2. Pin Configuration (All Pins Top View)

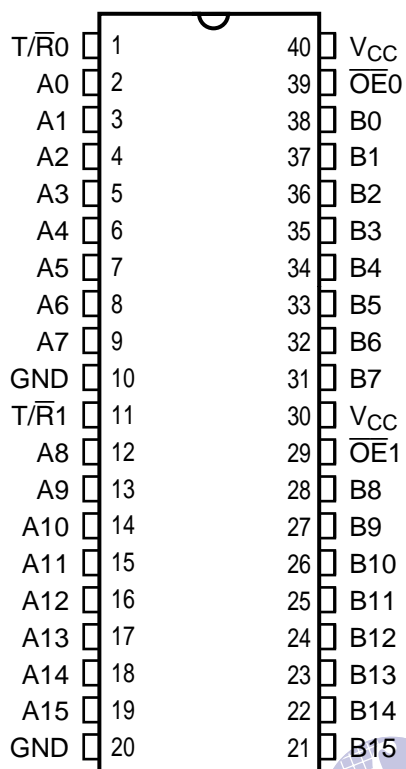

Table 1. Pin Description

| Name | I/O | Description |
|------------------|-----|-------------------------------|
| A _i | I/O | Data Bus A |
| B _i | I/O | Data Bus B |
| T/R0 | I | Direction for A/B7-A/B0 |
| T/R1 | I | Direction for A/B15-A/B8 |
| $\overline{OE}0$ | I | Output Enables for A/B7-A/B0 |
| $\overline{OE}1$ | I | Output Enables for A/B15-A/B8 |

Table 2. Function Table

| $\overline{OE}n$ | T/R _n | Bus A | Bus B | Function |
|------------------|------------------|--------|--------|----------------|
| H | X | Hi-Z | Hi-Z | Disable |
| L | L | Output | Input | Bus B to Bus A |
| L | H | Input | Output | Bus A to Bus B |

Table 3. Absolute Maximum Ratings

| | |
|---|----------------|
| Supply Voltage to Ground | -0.5V to +7.0V |
| DC Output Voltage V_{OUT} | -0.5V to +7.0V |
| DC Input Voltage V_{IN} | -0.5V to +7.0V |
| AC Input Voltage (for a pulse width ≤ 20 ns) | -3.0V |
| DC Input Diode Current with $V_{IN} < 0$ | -20mA |
| DC Output Diode Current with $V_{OUT} < 0$ | -50mA |
| DC Output Current Max. Sink Current/Pin | 120mA |
| Maximum Power Dissipation | 1.2 Watts |
| T_{STG} Storage Temperature | -65° to +150°C |

Note: Stresses greater than those listed under ABSOLUTE MAXIMUM RATINGS may cause permanent damage to this device resulting in functional or reliability type failures.

Table 4. Capacitance

$T_A = 25^\circ\text{C}$, $f = 1\text{MHz}$, $V_{IN} = 0\text{V}$, $V_{OUT} = 0\text{V}$

| Pins | Typ | Unit |
|--------------------------|-----|------|
| 1, 11, 29, 39 | 4 | pF |
| 2-9, 12-19, 21-28, 31-38 | 8 | pF |

Note: Capacitance is characterized but not tested.

Table 5. DC Electrical Characteristics Over Operating Range

Industral $T_A = -40^\circ\text{C}$ to 85°C , $V_{CC} = 5.0\text{V} \pm 5\%$

| Symbol | Parameter | Test Conditions | Min | Typ ⁽¹⁾ | Max | Unit |
|--------------------------|--|--|-----|--------------------|------|---------------|
| V_{IH} | Input HIGH Voltage | Logic HIGH for All Inputs | 2.0 | — | — | V |
| V_{IL} | Input LOW Voltage | Logic LOW for All Inputs | — | — | 0.8 | V |
| ΔV_T | Input Hysteresis | $V_{TLH} - V_{THL}$ for All Inputs ⁽³⁾ | — | 0.2 | — | V |
| $ I_{IH} $ $ I_{IL} $ | Input Current Input HIGH or LOW | $V_{CC} = \text{Max.}, 0 \leq V_{IN} < V_{CC}$ | — | — | 5 | μA |
| $ I_{OZ} $ | Off-State Output Current (Hi-Z) | $V_{CC} = \text{Max.}, 0 \leq V_{IN} \leq V_{CC}$ | — | — | 5 | μA |
| I_{OS} | Short Circuit Current FCT2X245 | $V_{CC} = \text{Max.}, V_{OUT} = \text{GND}^{(2,3)}$ | -60 | — | -225 | mA |
| I_{OR} | Current Drive FCT2X2245 (25 Ω) | $V_{CC} = \text{Max.}, V_{OUT} = 2.0\text{V}$ | 50 | — | — | mA |
| V_{IC} | Input Clamp Voltage | $V_{CC} = \text{Min.}, I_{IN} = -18\text{mA}^{(3)}$ | — | -0.7 | -1.2 | V |
| V_{OH} | Output HIGH Voltage | $V_{CC} = \text{Min.}, I_{OH} = -15\text{mA}$ | 2.4 | — | — | V |
| V_{OL} | Output LOW Voltage FCT2X245 | $V_{CC} = \text{Min.}, I_{OL} = 64\text{mA}$ | — | — | 0.55 | V |
| V_{OL} | Output LOW Voltage FCT2X2245 (25 Ω) | $V_{CC} = \text{Min.}, I_{OL} = 12\text{mA}$ | — | — | 0.50 | V |
| R_{OUT} | Output Resistance FCT2X2245 (25 Ω) | $V_{CC} = \text{Min.}, I_{OL} = 12\text{mA}$ | 20 | 28 | 40 | Ω |

Notes:

1. Typical values indicate $V_{CC} = 5.0\text{V}$ and $T_A = 25^\circ\text{C}$.
2. Not more than one output should be shorted and the duration is ≤ 1 second.
3. These parameters are guaranteed by design but not tested.

Table 6. Power Supply Characteristics

| Symbol | Parameter | Test Conditions ⁽¹⁾ | Min | Max | Unit |
|-----------------|-------------------------------------|--|-----|------|------------|
| I_{CC} | Quiescent Power Supply Current | $V_{CC} = \text{Max.}$, Freq = 0 $0V \leq V_{IN} \leq 0.2V$ or $V_{CC}-0.2V \leq V_{IN} \leq V_{CC}$ | — | 3.0 | mA |
| ΔI_{CC} | Supply Current per Input @ TTL HIGH | $V_{CC} = \text{Max.}$, $V_{IN} = 3.4V$, Freq = 0 ⁽²⁾ | — | 2.0 | mA |
| Q_{CCD} | Supply Current per Input per MHz | $V_{CC} = \text{Max.}$, Outputs Open and Enabled One Bit Toggling @ 50% Duty Cycle Other Inputs at GND or V_{CC} ^(3,4) | — | 0.25 | mA/ MHz |

Notes:

1. For conditions shown as Min. or Max., use the appropriate values specified under DC specifications.
2. Per TTL driven input ($V_{IN} = 3.4V$).
3. Q_{CCD} is a measurement of device power consumption only and does not include power to drive load capacitance or tester capacitance. This parameter is guaranteed by design but not tested.
4. I_C can be computed using the above parameters as explained in the Technical Overview section.

Table 7. Switching Characteristics Over Operating Range

Industrial: $T_A = -40^\circ\text{C}$ to 85°C , $V_{CC} = 5.0V \pm 5\%$

$C_{LOAD} = 50\text{pF}$, $R_{LOAD} = 500\Omega$ unless otherwise noted.

| Symbol | Description ⁽¹⁾ | 2X245A 2X2245A | | 2X245C 2X2245C | | Unit |
|------------------------|--|-------------------|-----|-------------------|-----|------|
| | | Min | Max | Min | Max | |
| t_{PHL} t_{PLH} | Propagation Delay Ai to Bi | 1.5 | 4.6 | 1.5 | 4.1 | ns |
| t_{PZH} t_{PZL} | Output Enable Time \overline{OE} , T/ \overline{R} to A/B | 1.5 | 6.2 | 1.5 | 5.8 | ns |
| t_{PHZ} t_{PLZ} | Output Disable Time ⁽²⁾ \overline{OE} , T/ \overline{R} to A/B | 1.5 | 5.0 | 1.5 | 4.5 | ns |

Notes:

1. Minimums guaranteed but not tested. See Test Circuit and Waveforms.
2. This parameter is guaranteed but not tested.