

FEATURES/BENEFITS

- 5V tolerant inputs and outputs
- Bus Hold feature holds last active state during 3-state operation
- 10 μ A I_{CCQ} quiescent power supply current
- Hot insertable
- 2.0V–3.6V V_{CC} supply operation
- \pm 24mA balanced output drive
- Power down high impedance inputs and outputs
- t_{PD} = 4.7ns max.
- Input hysteresis for noise immunity
- Meets or exceeds JEDEC Standard 36 specifications
- Multiple power and ground pins for low noise
- Operating temperature range:
 –40°C to 85°C
- Latch-up performance exceeds 500mA
- ESD performance:
 Human body model > 2000V
 Machine model > 200V
- Packages available:
 56-pin TSSOP
 56-pin SSOP

DESCRIPTION

The LVCH16601A is an 18-bit registered bus transceiver with three-state outputs that are ideal for driving address and data buses. These high-speed, low-power registered transceivers combine D-type latches and D-type flip-flops to allow data flow in transparent, latched and clocked modes. The clocks can be controlled by the active-low clock-enable inputs. The QS74LVCH16601A provides Bus Hold circuitry on the data inputs to retain the last active state during 3-state operation, eliminating the need for external pull-up resistors. The 3.3V LVC family features low power, low switching noise, and fast switching speeds for low power portable applications as well as high-end advanced workstations applications. 5V tolerant inputs and outputs allow this LVC product to be used in mixed 5V and 3.3V applications. Easy board layout is facilitated by the use of flow-through pinouts and byte enable controls provide architectural flexibility for systems designers. To accommodate hot-plug or live insertion applications, both versions of this product were designed not to load an active bus when V_{CC} is removed. However, during power up or power down sequence, \overline{OE} should be tied to V_{CC} to ensure high-impedance state on the outputs.

Figure 1. Functional Block Diagram

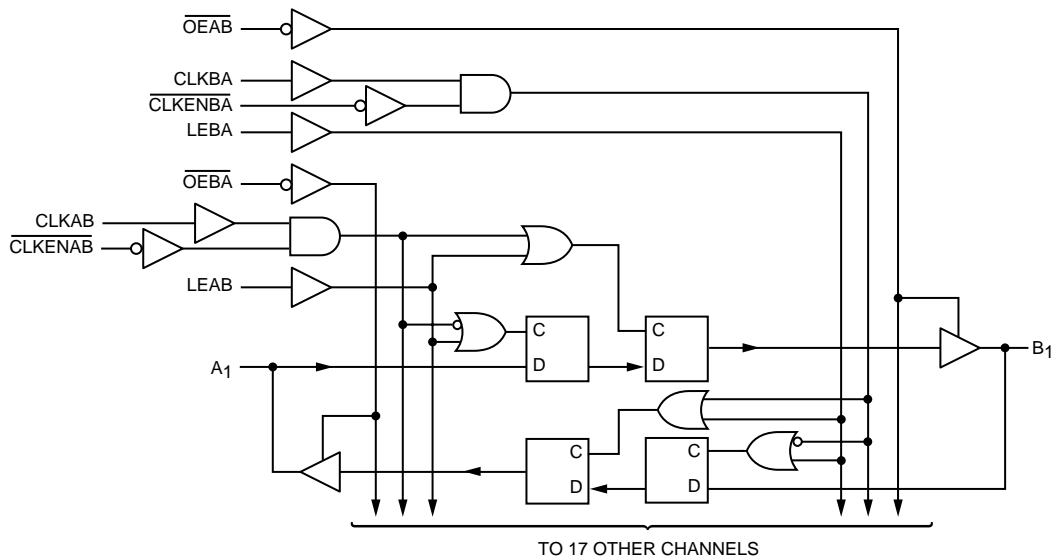

Figure 2. Pin Configuration
(All Pins Top View)

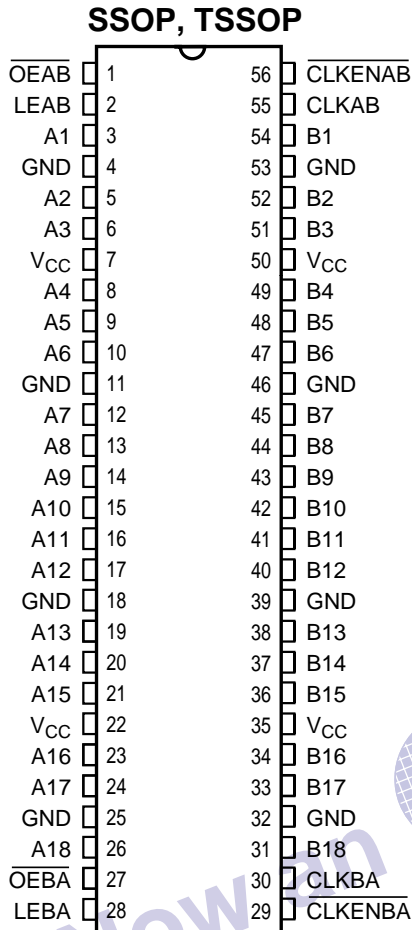

Table 1. Pin Description

Name	Description
\overline{OEAB}	A-to-B Output Enable Input (Active Low)
\overline{OEBA}	B-to-A Output Enable Input (Active Low)
LEAB	A-to-B Latch Enable Input
LEBA	B-to-A Latch Enable Input
CLKAB	A-to-B Clock Input
CLKBA	B-to-A Clock Input
Ax	A-to-B Data Inputs or B-to-A 3-State Outputs
Bx	B-to-A Data Inputs or A-to-B 3-State Outputs
$\overline{CLKENAB}$	A-to-B Clock Enable (Active Low)
$\overline{CLKENBA}$	B-to-A Clock Enable (Active Low)

Table 2. Function Table ⁽¹⁾

Inputs					Outputs
$\overline{CLKENAB}$	\overline{OEAB}	LEAB	CLKAB	Ax	Bx
X	H	X	X	X	Z
X	L	H	X	L	L
X	L	H	X	H	H
H	L	L	X	X	B ⁽²⁾
H	L	L	X	X	B ⁽²⁾
L	L	L	↑	L	L
L	L	L	↑	H	H
L	L	L	L	X	B ⁽²⁾
L	L	L	H	X	B ⁽³⁾

Notes:

1. A-to-B data flow is shown. B-to-A data flow is similar but uses \overline{OEBA} , LEBA, CLKBA and $\overline{CLKENBA}$.
2. Output level before the indicated steady-state input conditions were established.
3. Output level before the indicated steady-state input conditions were established, provided that CLKAB was HIGH before LEAB went LOW.

Table 3. Absolute Maximum Ratings

Supply Voltage to Ground	-0.5V to 7.0V
DC Output Voltage V_{OUT}	
Outputs HIGH-Z	-0.5V to 7.0V
Outputs Active	-0.5V to $V_{CC} + 0.5V$
DC Input Voltage V_{IN}	-0.5V to 7.0V
DC Input Diode Current with $V_{IN} < 0$	-50mA
DC Output Diode Current	
$V_O < 0$	-50mA
$V_O > V_{CC}$	50mA
DC Output Source/Sink Current (I_{OH}/I_{OL})	$\pm 50mA$
DC Supply Current per Supply Pin	$\pm 100mA$
DC Ground Current per Ground Pin	$\pm 100mA$
T_{STG} Storage Temperature	-65°C to 150°C

Note: Stresses greater than those listed under ABSOLUTE MAXIMUM RATINGS may cause permanent damage to this device resulting in functional or reliability type failures.

Table 4. Recommended Operating Conditions

Symbol	Parameter	Min	Max	Unit	
V_{CC}	Supply Voltage, Operating	2.0	3.6	V	
	Supply Voltage, Data Retention Only	1.5	3.6		
V_{IH}	Input HIGH Voltage	$V_{OL} = 2.7$ to 3.6V	2.0	—	V
V_{IL}	Input LOW Voltage	$V_{CC} = 2.7$ to 3.6V	—	0.8	V
V_{IN}	Input Voltage	0	5.5	V	
V_{OUT}	Output Voltage in Active State	0	V_{CC}	V	
	Output Voltage in "OFF" State	0	5.5		
I_{OH}	Output Current HIGH	$V_{CC} = 3.0-3.6V$	—	-24	mA
		$V_{CC} = 2.7V$		-12	
I_{OL}	Output Current LOW	$V_{CC} = 3.0-3.6V$	—	24	mA
		$V_{CC} = 2.7V$	—	12	
$\Delta t/\Delta v$	Input Transition Slew Rate	—	10	ns/V	
T_A	Operating Free Air Temperature	-40	85	°C	

QS74LVCH16601A ADVANCE INFORMATION

Table 5. DC Electrical Characteristics Over Operating Range

Industrial Temperature Range, $T_A = -40^{\circ}\text{C}$ to 85°C

Symbol	Parameter	Test Conditions	Min	Typ ⁽¹⁾	Max	Unit
V_{OH}	Output HIGH Voltage	$V_{CC} = 2.7\text{V}, I_{OH} = -100\mu\text{A}$ $V_{CC} = 2.7\text{V}, I_{OH} = -12\text{mA}$ $V_{CC} = 3.0\text{V}, I_{OH} = -12\text{mA}$ $V_{CC} = 3.0\text{V}, I_{OH} = -24\text{mA}$	$V_{CC} - 0.2$ 2.2 2.4 2.2	— — — —	— — — —	V
V_{OL}	Output LOW Voltage	$V_{CC} = 2.7\text{V}, I_{OL} = 100\mu\text{A}$ $V_{CC} = 2.7\text{V}, I_{OL} = 12\text{mA}$ $V_{CC} = 3.0\text{V}, I_{OL} = 24\text{mA}$	— — —	— — —	0.2 0.4 0.55	V
V_{IK}	Input Clamp Voltage	$V_{CC} = 2.7\text{V}, I_{IN} = -18\text{mA}$	—	-0.7	-1.2	V
I_I	Input Leakage Current	$V_I = 0\text{V}, V_I = 5.5\text{V}, V_{CC} = 3.6\text{V}$	—	—	± 1.0	μA
$ I_{BH} $	Bus Hold Inputs Overdrive Current ^(2,3)	$V_{CC} = 3.6\text{V}, V_{IN} = 0\text{V}$ or $V_{IN} = V_{CC}$ $V_{CC} = 3.6\text{V}, 0.8\text{V} < V_{IN} < 2.0\text{V}$	— —	— —	50 500 ⁽⁴⁾	μA
I_{BHH} I_{BHL}	Bus Hold Input Sustaining Current	$V_{CC} = 3\text{V}$ $V_{IN} = 2.0\text{V}$ $V_{IN} = 0.8\text{V}$	-75 75	— —	— —	μA
I_{OZ}	High-Z I/O Leakage	$V_O = 0\text{V}, V_O = 5.5\text{V},$ $V_I = V_{IH}$ or $V_{IL}, V_{CC} = 3.6\text{V}$	—	—	± 1.0	μA
I_{OFF}	Power Off Leakage	$V_{CC} = 0\text{V}, V_I$ or $V_O = 5.5\text{V}$	—	—	10	μA
I_{CC}	Quiescent Power Supply Current	$V_{CC} = 3.6\text{V}, V_{IN} = V_{CC}$ or GND	—	0.1	10	μA
ΔI_{CC}	Quiescent Power Supply Current per Control Inputs at TTL HIGH	$V_{CC} = 3.6\text{V}, V_{IN} = V_{CC} - 0.6\text{V}^{(5)}$	—	2.0	3.0	μA
	Quiescent Power Supply Current per Bus Hold Inputs at TTL HIGH	$V_{CC} = 3.6\text{V}, V_{IN} = V_{CC} - 0.6\text{V}^{(5)}$	—	75	500	μA

Notes:

1. Typical values are at $V_{CC} = 3.3\text{V}$ and $T_A = 25^{\circ}\text{C}$.
2. These parameters are guaranteed by characterization, but not production tested.
3. Pins with Bus Hold are identified in the pin description.
4. An external driver must provide at least $|I_{BH}|$ during transition to guarantee that the Bus Hold input will change state.
5. Per TTL driven input. All other inputs at V_{CC} or GND.

Table 6. Dynamic Switching Characteristics

Symbol	Parameter	Test Conditions	Typ ⁽¹⁾	Unit
V_{OLP}	Quiet Output Dynamic Peak V_{OL}	$C_L = 50\text{pF}, V_{CC} = 3.3\text{V}$ $V_{IH} = 3.3\text{V}, V_{IL} = 0\text{V}$	0.8	V
V_{OLV}	Quiet Output Dynamic Valley V_{OL}	$C_L = 50\text{pF}, V_{CC} = 3.3\text{V}$ $V_{IH} = 3.3\text{V}, V_{IL} = 0\text{V}$	0.8	V
C_{PD}	Power Dissipation	$C_L = 50\text{pF}, f = 10\text{MHz},$ $V_{CC} = 3.3 \pm 0.3\text{V}$	Output Enable Output Disable	35 6
				pF

Note:

1. Typical values are at $V_{CC} = 3.3\text{V}$, 25°C ambient.

Table 7. Capacitance⁽¹⁾

Symbol	Pins	Conditions	Typ	Unit
C _{IN}	Input Capacitance	V _{IN} = 0V, V _{OUT} = 0V, f = 1MHz	7.0	pF
C _{I/O}	I/O Capacitance	V _{IN} = 0V, V _{OUT} = 0V, f = 1MHz	8.0	pF

Note:

1. Capacitance is characterized but not production tested.

Table 8. Switching Characteristics Over Operating Range

Industrial Temperature Range, T_A = -40°C to 85°C.

C_{LOAD} = 50pF, R_{LOAD} = 500Ω unless otherwise noted.

Symbol	Description ⁽¹⁾	V _{CC} = 3.3 ± 0.3V		V _{CC} = 2.7V ⁽²⁾		Unit
		Min.	Max.	Min.	Max.	
f _{MAX}	CLKAB or CLKBA Frequency ⁽²⁾	150	—	150	—	MHz
t _{PD}	Propagation Delay Ax to Bx or Bx to Ax	1.5	4.7	1.5	5.7	ns
	Propagation Delay LEBA to Ax, LEAB to Bx	1.5	5.2	1.5	6.2	
	Propagation Delay CLKBA to Ax, CLKAB to Bx	1.5	5.2	1.5	6.2	
t _{EN}	Output Enable Time OEBA to Ax, OEAB to Bx	1.5	5.8	1.5	6.8	ns
t _{DIS}	Output Disable Time ⁽²⁾ OEBA to Ax, OEAB to Bx	1.5	5.0	1.5	6.0	ns
t _{SU}	Setup Time HIGH or LOW Ax to CLKAB, Bx to CLKBA	2.5	—	2.5	—	ns
t _H	Hold Time HIGH or LOW Ax to CLKAB, Bx to CLKBA	0	—	0	—	ns
t _{SU}	Setup Time HIGH or Low Ax to LEAB Bx to LEBA	Clock LOW	1.5	—	1.5	3ns
		Clock HIGH	2.0	—	2.0	ns
t _H	Hold Time HIGH or LOW Ax to LEAB, Bx to LEBA	1.5	—	1.5	—	ns
t _W	LEAB or LEBA Pulse Width HIGH ⁽²⁾	3.0	—	3.0	—	ns
t _W	CLKAB or CLKBA Pulse Width HIGH or LOW ⁽²⁾	3.0	—	3.0	—	ns
t _{SK(O)}	Output Skew ⁽³⁾	—	0.5	—	0.5	ns

Notes:

1. Minimums guaranteed but not tested. See Test Circuit and Waveforms.
2. Guaranteed by characterization.
3. Skew between any two outputs of the same package switching in the same direction. This parameter is guaranteed by characterization but not production tested.

TEST CIRCUIT AND WAVEFORMS

Figure 3. Test Circuit

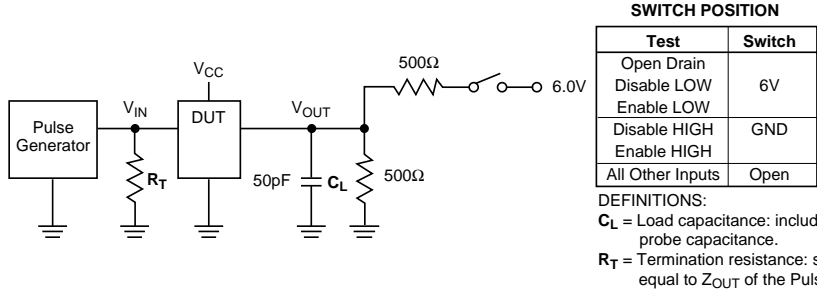

Figure 4. Setup, Hold, and Release Timing

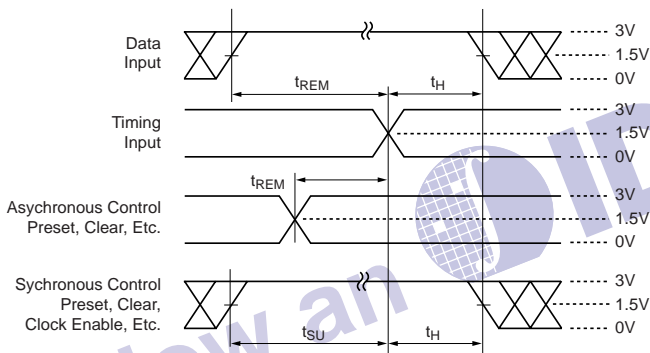

Figure 6. Pulse Width

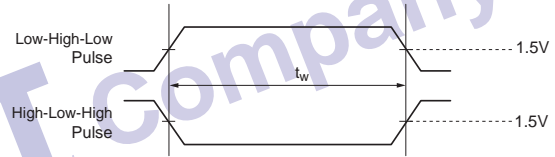

Figure 5. Enable and Disable Timing

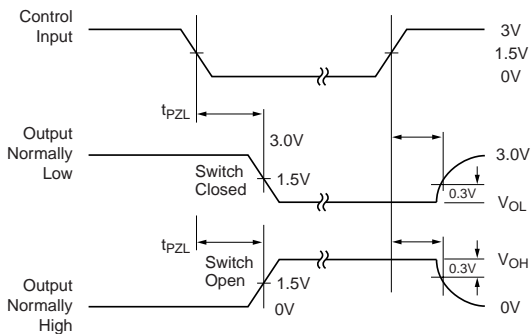
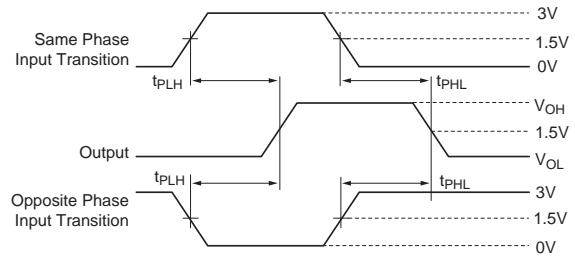

Figure 7. Propagation Delay



Notes:

1. Input Control Enable = LOW and Input Control Disable = HIGH.
2. Pulse Generator for All Pulses: Rate \leq 1.0MHz;
 $Z_{OUT} \leq 50\Omega$; t_F , $t_R \leq 2.5ns$.

ORDERING INFORMATION

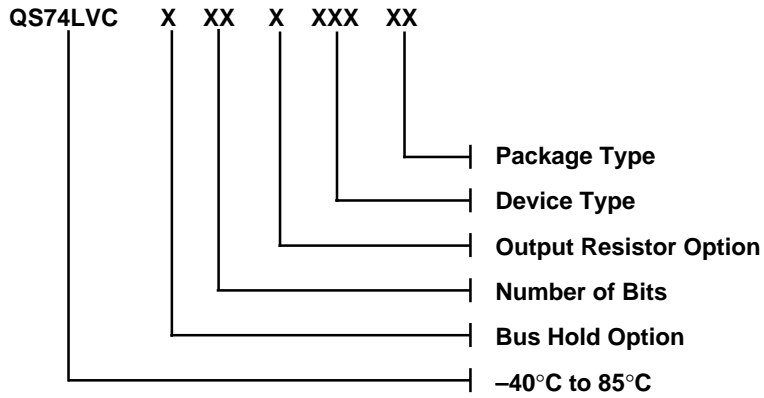

Bus Hold Option:
H – with Bus Hold

Number of Bits:
16 – 18-Bit

Output Resistor Option:
Blank – No Output Resistor

Device Type:
601

Package Type:
PV – SSOP, 300 mil
PA – TSSOP, 240 mil

Now an  IDT™ company