



## SYNCHRONOUS PRESETTABLE 4-BIT COUNTER

- HIGH SPEED:  
 $f_{MAX} = 180 \text{ MHz (TYP.) at } V_{CC} = 3.3 \text{ V}$
- COMPATIBLE WITH TTL OUTPUTS
- LOW POWER DISSIPATION:  
 $I_{CC} = 4 \mu\text{A (MAX.) at } T_A = 25^\circ\text{C}$
- LOW NOISE:  
 $V_{OLP} = 0.3\text{V (TYP.) at } V_{CC} = 3.3\text{V}$
- $75\Omega$  TRANSMISSION LINE DRIVING CAPABILITY
- SYMMETRICAL OUTPUT IMPEDANCE:  
 $|I_{OH}| = I_{OL} = 12\text{mA (MIN.) at } V_{CC} = 3.0 \text{ V}$
- PCI BUS LEVELS GUARANTEED AT 24 mA
- BALANCED PROPAGATION DELAYS:  
 $t_{PLH} \cong t_{PHL}$
- OPERATING VOLTAGE RANGE:  
 $V_{CC(OPR)} = 2\text{V to } 3.6\text{V (1.2V Data Retention)}$
- PIN AND FUNCTION COMPATIBLE WITH 74 SERIES 161
- IMPROVED LATCH-UP IMMUNITY

### DESCRIPTION

The 74LVQ161 is a low voltage CMOS SYNCHRONOUS PRESETTABLE COUNTER fabricated with sub-micron silicon gate and double-layer metal wiring C<sup>2</sup>MOS technology. It is ideal for low power and low noise 3.3V applications. It is a 4 bit binary counter with Asynchronous Clear.

The circuit have four fundamental modes of operation, in order of preference: synchronous

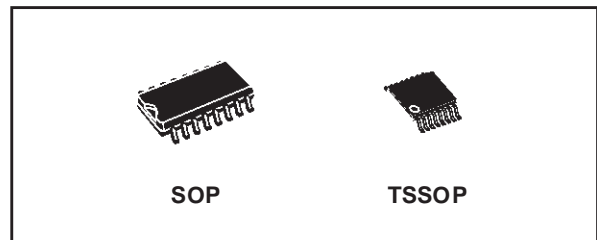

### ORDER CODES

PACKAGE	TUBE	T & R
SOP	74LVQ161M	74LVQ161MTR
TSSOP		74LVQ161TTR

reset, parallel load, count-up and hold. Four control inputs, Master Reset (CLEAR), Parallel Enable Input (PE) and Count Enable Carry Input (TE), determine the mode of operation as shown in the Truth Table. A LOW signal on CLEAR overrides counting and parallel loading and sets all outputs on LOW state. A LOW signal on LOAD overrides counting and allows information on Parallel Data Qn inputs to be loaded into the flip-flops on the next rising edge of CLOCK. With LOAD and CLEAR, PE and TE permit counting when both are high. Conversely, a LOW signal on either PE and TE inhibits counting. All inputs and outputs are equipped with protection circuits against static discharge, giving them 2KV ESD immunity and transient excess voltage.

### PIN CONNECTION AND IEC LOGIC SYMBOLS

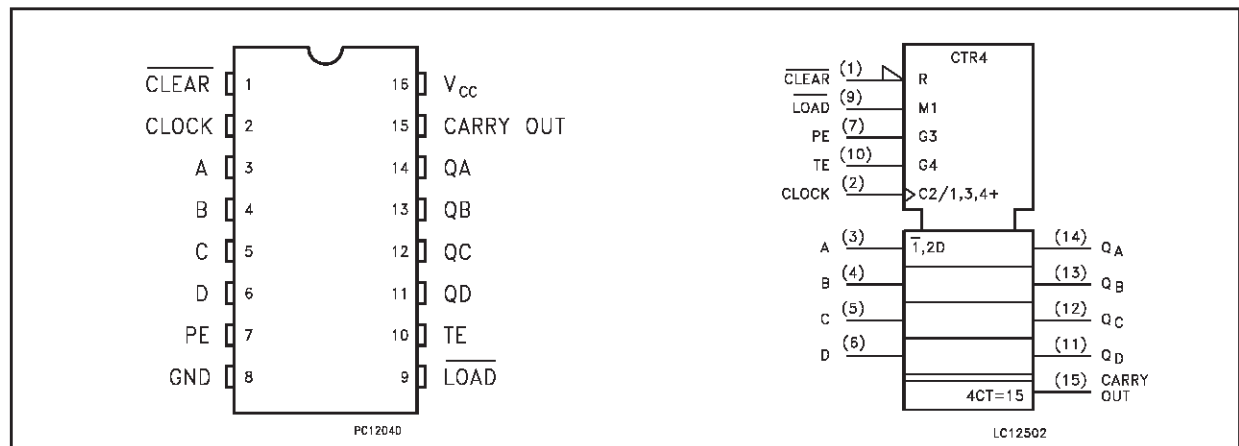

INPUT AND OUTPUT EQUIVALENT CIRCUIT

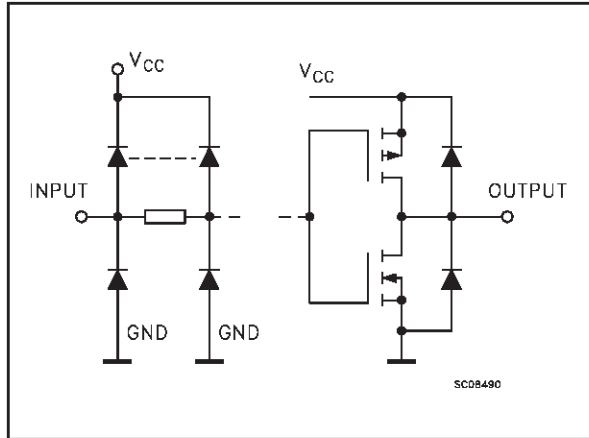

PIN DESCRIPTION

PIN No	SYMBOL	NAME AND FUNCTION
1	CLEAR	Asynchronous Master Reset
2	CLOCK	Clock Input (LOW to HIGH Edge Trigger)
3, 4, 5, 6	A, B, C, D	Data Inputs
7	PE	Count Enable Input
10	TE	Count Enable Carry Input
9	LOAD	Parallel Enable Input
14, 13, 12, 11	QA to QD	Flip-Flop Outputs
15	CARRY OUT	Terminal Count Output
8	GND	Ground (0V)
16	V <sub>CC</sub>	Positive Supply Voltage

TRUTH TABLE

INPUTS					OUTPUTS				FUNCTION
CLEAR	LOAD	PE	TE	CK					
L	X	X	X	X	L	L	L	L	RESET TO "0"
H	L	X	X		A	B	C	D	PRESET DATA
H	H	X	L		NO CHANGE				NO COUNT
H	H	L	X		NO CHANGE				NO COUNT
H	H	H	H		COUNT UP				COUNT
H	X	X	X		NO CHANGE				NO COUNT

X : Don't Care; A, B, C, D; Logic level of data input; CARRY OUT : TE x QA x QB x QC x QD

## LOGIC DIAGRAM

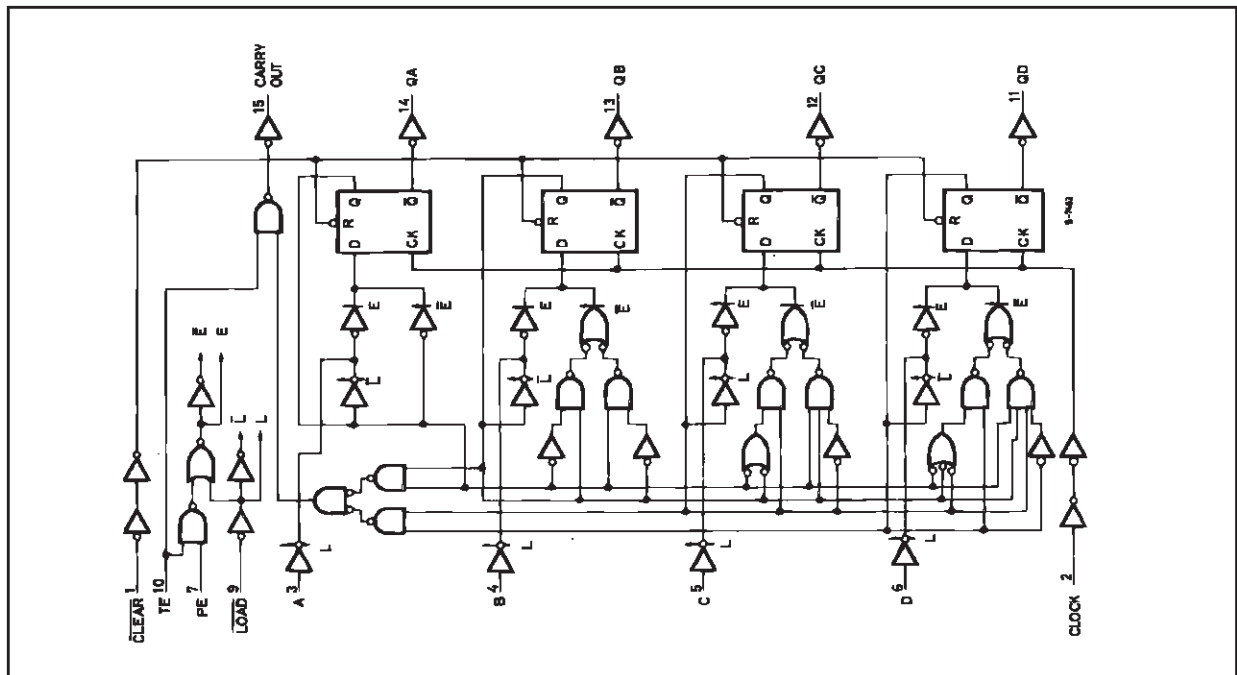

## TIMING CHART

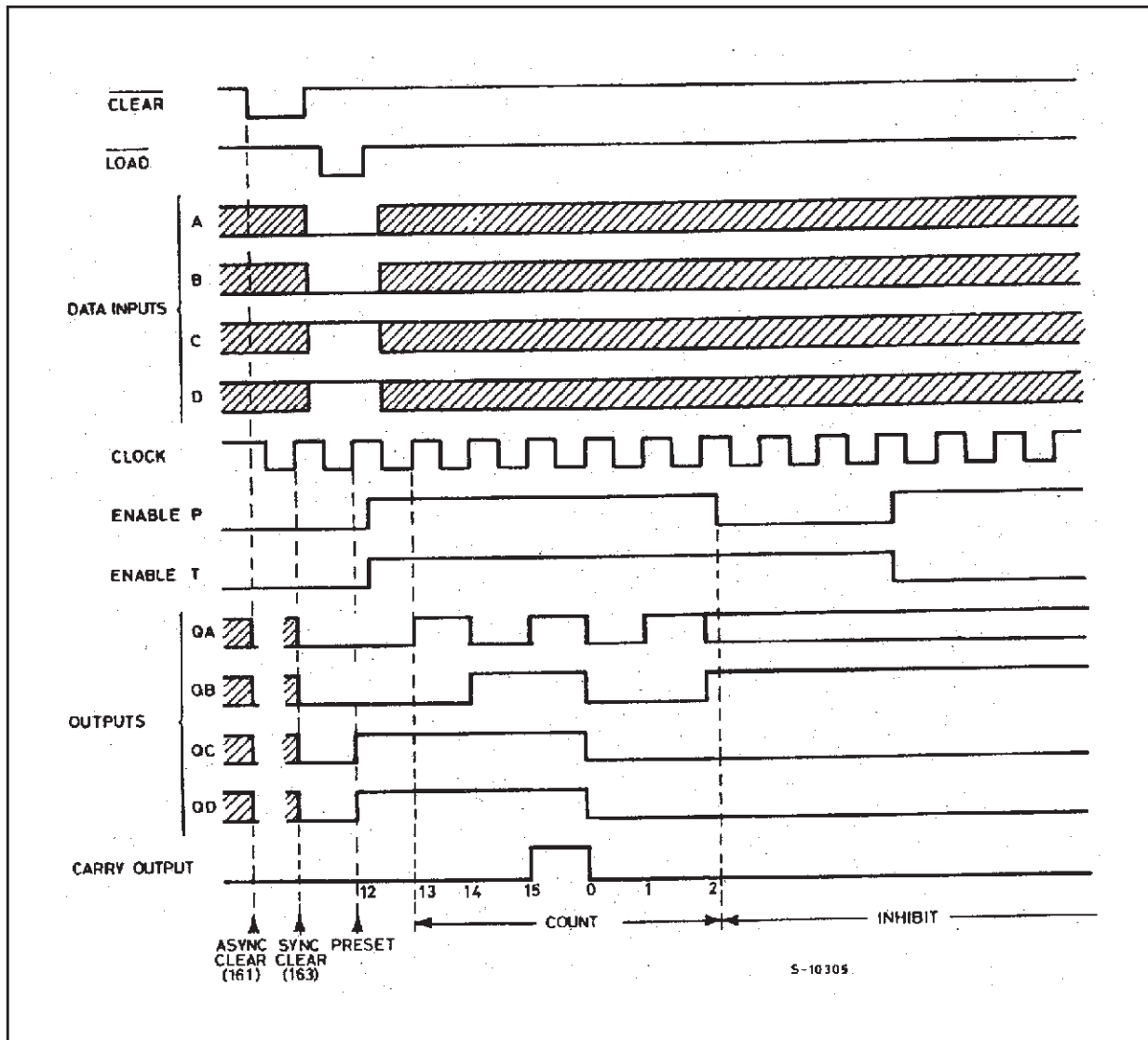

## ABSOLUTE MAXIMUM RATINGS

Symbol	Parameter	Value	Unit
$V_{CC}$	Supply Voltage	-0.5 to +7	V
$V_I$	DC Input Voltage	-0.5 to $V_{CC} + 0.5$	V
$V_O$	DC Output Voltage	-0.5 to $V_{CC} + 0.5$	V
$I_{IK}$	DC Input Diode Current	$\pm 20$	mA
$I_{OK}$	DC Output Diode Current	$\pm 20$	mA
$I_O$	DC Output Current	$\pm 50$	mA
$I_{CC}$ or $I_{GND}$	DC $V_{CC}$ or Ground Current	$\pm 300$	mA
$T_{stg}$	Storage Temperature	-65 to +150	$^{\circ}C$
$T_L$	Lead Temperature (10 sec)	300	$^{\circ}C$

Absolute Maximum Ratings are those values beyond which damage to the device may occur. Functional operation under these conditions is not implied.

## RECOMMENDED OPERATING CONDITIONS

Symbol	Parameter	Value	Unit
$V_{CC}$	Supply Voltage (note 1)	2 to 3.6	V
$V_I$	Input Voltage	0 to $V_{CC}$	V
$V_O$	Output Voltage	0 to $V_{CC}$	V
$T_{op}$	Operating Temperature	-55 to 125	°C
dt/dv	Input Rise and Fall Time $V_{CC} = 3.0V$ (note 2)	0 to 10	ns/V

1) Truth Table guaranteed: 1.2V to 3.6V

2)  $V_{IN}$  from 0.8V to 2V

## DC SPECIFICATIONS

Symbol	Parameter	Test Condition		Value						Unit	
				$T_A = 25^\circ C$			$-40$ to $85^\circ C$		$-55$ to $125^\circ C$		
		$V_{CC}$ (V)		Min.	Typ.	Max.	Min.	Max.	Min.		Max.
$V_{IH}$	High Level Input Voltage	3.0 to 3.6		2.0			2.0		2.0		V
$V_{IL}$	Low Level Input Voltage				0.8		0.8		0.8		V
$V_{OH}$	High Level Output Voltage	3.0	$I_O = -50 \mu A$	2.9	2.99		2.9		2.9		V
			$I_O = -12 mA$	2.58			2.48		2.48		
			$I_O = -24 mA$				2.2		2.2		
$V_{OL}$	Low Level Output Voltage	3.0	$I_O = 50 \mu A$		0.002	0.1		0.1		0.1	V
			$I_O = 12 mA$		0	0.36		0.44		0.44	
			$I_O = 24 mA$					0.55		0.55	
$I_I$	Input Leakage Current	3.6	$V_I = V_{CC}$ or GND			$\pm 0.1$		$\pm 1$		$\pm 1$	$\mu A$
$I_{CC}$	Quiescent Supply Current	3.6	$V_I = V_{CC}$ or GND			4		40		40	$\mu A$
$I_{OLD}$	Dynamic Output Current (note 1, 2)	3.6	$V_{OLD} = 0.8 V$ max				36		25		mA
$I_{OHD}$			$V_{OHD} = 2 V$ min				-25		-25		mA

1) Maximum test duration 2ms, one output loaded at time

2) Incident wave switching is guaranteed on transmission lines with impedances as low as 75 $\Omega$

## DYNAMIC SWITCHING CHARACTERISTICS

Symbol	Parameter	Test Condition		Value						Unit	
		V <sub>CC</sub> (V)		T <sub>A</sub> = 25°C			-40 to 85°C		-55 to 125°C		
				Min.	Typ.	Max.	Min.	Max.	Min.		Max.
V <sub>OLP</sub>	Dynamic Low Voltage Quiet Output (note 1, 2)	3.3	C <sub>L</sub> = 50 pF		0.3	0.8					V
V <sub>OLV</sub>				-0.8	-0.3						
V <sub>IHD</sub>	Dynamic High Voltage Input (note 1, 3)	3.3		2							V
V <sub>ILD</sub>	Dynamic Low Voltage Input (note 1, 3)	3.3				0.8					V

1) Worst case package.

2) Max number of outputs defined as (n). Data inputs are driven 0V to 3.3V, (n-1) outputs switching and one output at GND.

3) Max number of data inputs (n) switching. (n-1) switching 0V to 3.3V. Inputs under test switching: 3.3V to threshold (V<sub>ILD</sub>), 0V to threshold (V<sub>IHD</sub>), f=1MHz.

AC ELECTRICAL CHARACTERISTICS ( $C_L = 50 \text{ pF}$ ,  $R_L = 500 \Omega$ , Input  $t_r = t_f = 3\text{ns}$ )

Symbol	Parameter	Test Condition		Value						Unit	
		$V_{CC}$ (V)		$T_A = 25^\circ\text{C}$			$-40 \text{ to } 85^\circ\text{C}$		$-55 \text{ to } 125^\circ\text{C}$		
				Min.	Typ.	Max.	Min.	Max.	Min.		Max.
$t_{PLH}$ $t_{PHL}$	Propagation Delay Time CK to Q	2.7			8.0	13.0		15.0		17.0	ns
		3.3(*)			6.8	9.5		11.0		12.5	
$t_{PLH}$ $t_{PHL}$	Propagation Delay Time CK to CARRY OUT	2.7			9.1	14.0		16.0		18.5	ns
		3.3(*)			7.5	10.5		12.0		14.0	
$t_{PLH}$ $t_{PHL}$	Propagation Delay Time TE to CARRY OUT	2.7			5.6	10.0		11.5		13.0	ns
		3.3(*)			4.7	8.0		9.5		10.5	
$t_{PHL}$	Propagation Delay Time CLR to Q	2.7			8.0	12.0		15.0		17.0	ns
		3.3(*)			6.1	9.5		11.0		12.5	
$t_{PHL}$	Propagation Delay Time CLR to CARRY OUT	2.7			8.0	14.0		16.0		18.5	ns
		3.3(*)			6.7	10.5		12.0		14.0	
$t_{W(L)}$	CLR Pulse Width, LOW (LOAD)	2.7		4.0	1.9		4.0		4.0		ns
		3.3(*)		3.0	1.9		3.0		3.0		
$t_W$	CLOCK Pulse Width, HIGH or LOW	2.7		4.0	1.9		4.0		4.0		ns
		3.3(*)		3.0	1.9		3.0		3.0		
$t_s$	Setup Time HIGH or LOW (INPUT to CLOCK)	2.7		5.0	2.5		5.0		5.0		ns
		3.3(*)		4.0	2.1		4.0		4.0		
$t_h$	Hold Time HIGH or LOW (INPUT to CLOCK)	2.7		1	-1.3		1		1		ns
		3.3(*)		0.5	-1.0		0.5		0.5		
$t_s$	Setup Time HIGH or LOW (LOAD to CLOCK)	2.7		3.0	1.5		3.0		3.0		ns
		3.3(*)		2.5	1.2		2.5		2.5		
$t_h$	Hold Time HIGH or LOW (LOAD to CLOCK)	2.7		1	-0.6		1		1		ns
		3.3(*)		0.5	-0.5		0.5		0.5		
$t_s$	Setup Time HIGH or LOW (PE or TE to CLOCK)	2.7		7.0	3.4		7.0		7.0		ns
		3.3(*)		6.0	3.0		6.0		6.0		
$t_h$	Hold Time HIGH or LOW (PE or TE to CLOCK)	2.7		0	-2.6		0		0		ns
		3.3(*)		0	-2.2		0		0		
$t_{REM}$	Recovery Time CLR to CK	2.7		1	-0.8		1		1		ns
		3.3(*)		0.5	-0.6		0.5		0.5		
$f_{MAX}$	Maximum Clock Frequency	2.7		100	150		80		60		MHz
		3.3(*)		120	180		100		80		
$t_{OSLH}$ $t_{OSHL}$	Output To Output Skew Time (note1, 2)	2.7			0.5	1.0		1.0		1.0	ns
		3.3(*)			0.5	1.0		1.0		1.0	

1) Skew is defined as the absolute value of the difference between the actual propagation delay for any two outputs of the same device switching in the same direction, either HIGH or LOW ( $t_{OSLH} = |t_{PLHm} - t_{PLHn}|$ ,  $t_{OSHL} = |t_{PHLm} - t_{PHLn}|$ )

2) Parameter guaranteed by design

(\*) Voltage range is  $3.3V \pm 0.3V$

**CAPACITIVE CHARACTERISTICS**

Symbol	Parameter	Test Condition		Value						Unit	
		V <sub>CC</sub> (V)		T <sub>A</sub> = 25°C			-40 to 85°C		-55 to 125°C		
				Min.	Typ.	Max.	Min.	Max.	Min.		Max.
C <sub>IN</sub>	Input Capacitance	3.3			4						pF
C <sub>PD</sub>	Power Dissipation Capacitance (note 1)	3.3	f <sub>IN</sub> = 10MHz		16						pF

1) C<sub>PD</sub> is defined as the value of the IC's internal equivalent capacitance which is calculated from the operating current consumption without load. (Refer to Test Circuit). Average operating current can be obtained by the following equation. I<sub>CC(opr)</sub> = C<sub>PD</sub> × V<sub>CC</sub> × f<sub>IN</sub> + I<sub>CC</sub>/n (per circuit)

**TEST CIRCUIT**

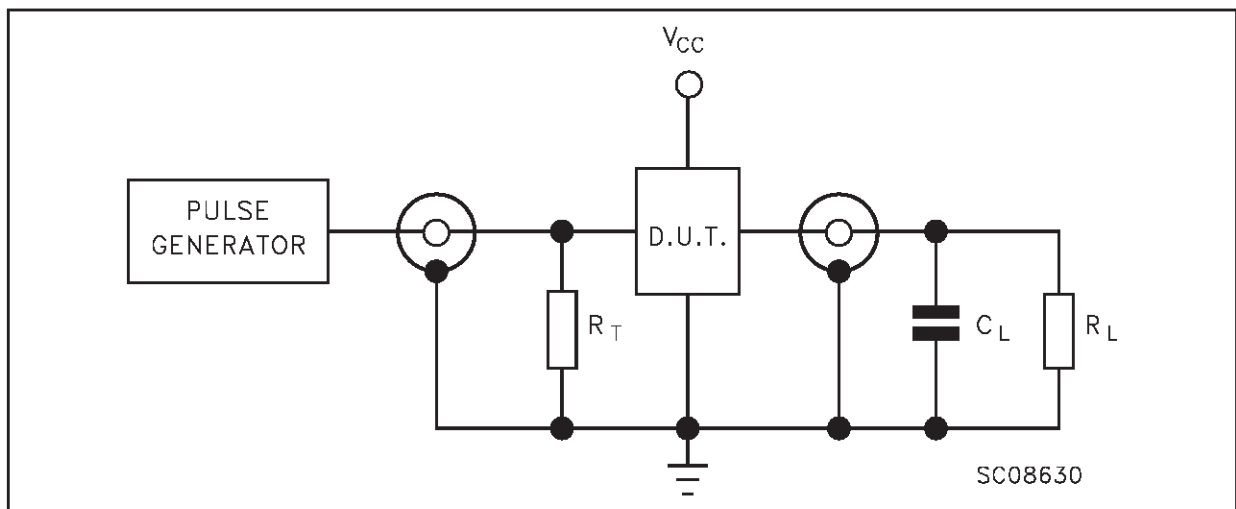

C<sub>L</sub> = 50pF or equivalent (includes jig and probe capacitance)  
 R<sub>L</sub> = 500Ω or equivalent  
 R<sub>T</sub> = Z<sub>OUT</sub> of pulse generator (typically 50Ω)

**WAVEFORM 1 : PROPAGATION DELAYS , COUNT MODE (f=1MHz; 50% duty cycle)**

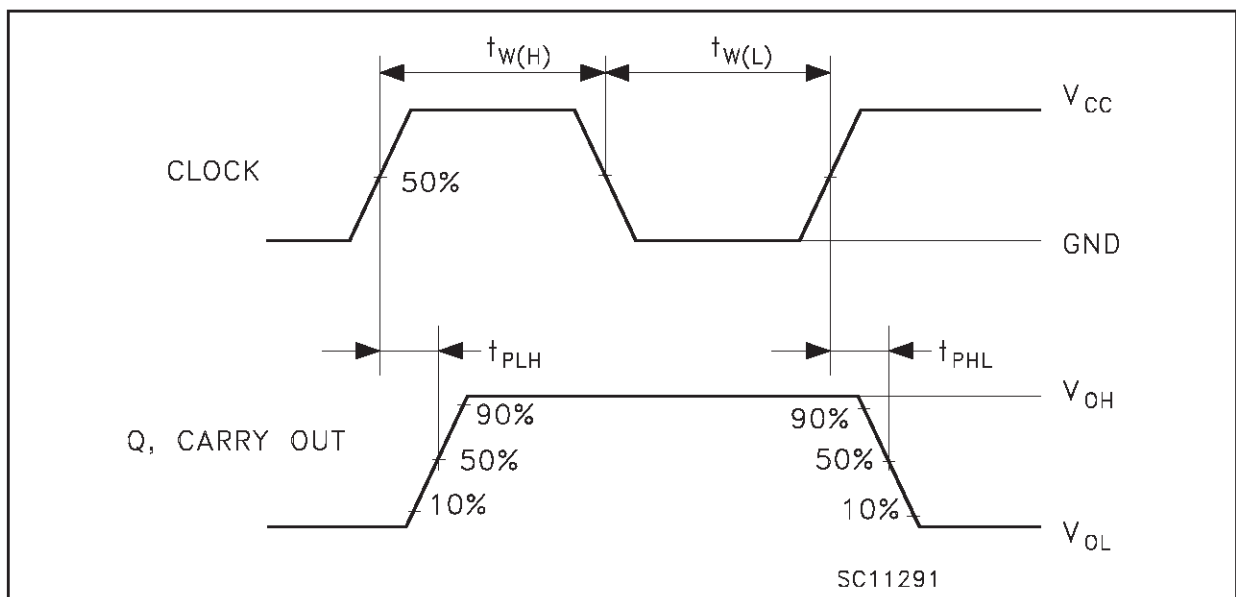

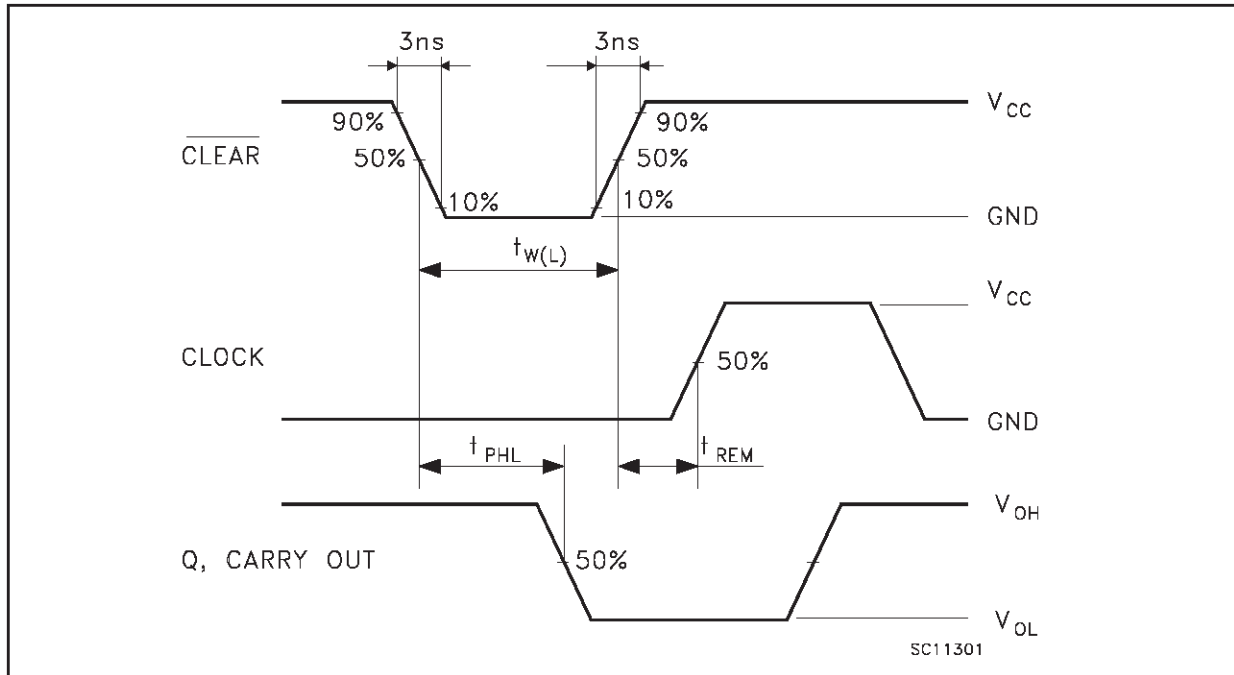
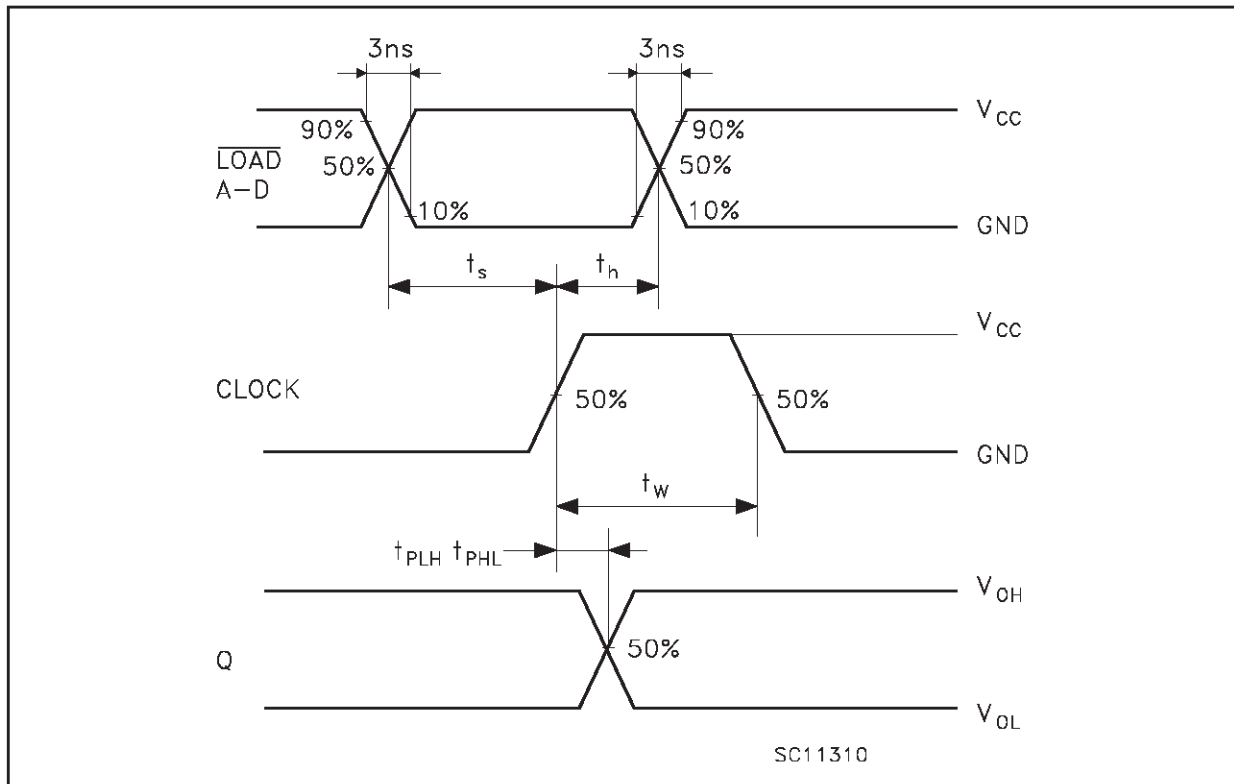

**WAVEFORM 2: PROPAGATION DELAYS CLEAR MODE** ( $f=1\text{MHz}$ ; 50% duty cycle)**WAVEFORM 3: PROPAGATION DELAYS PRESET MODE** ( $f=1\text{MHz}$ ; 50% duty cycle)

WAVEFORM 4: PROPAGATION DELAYS COUNTABLE MODE (f=1MHz; 50% duty cycle)

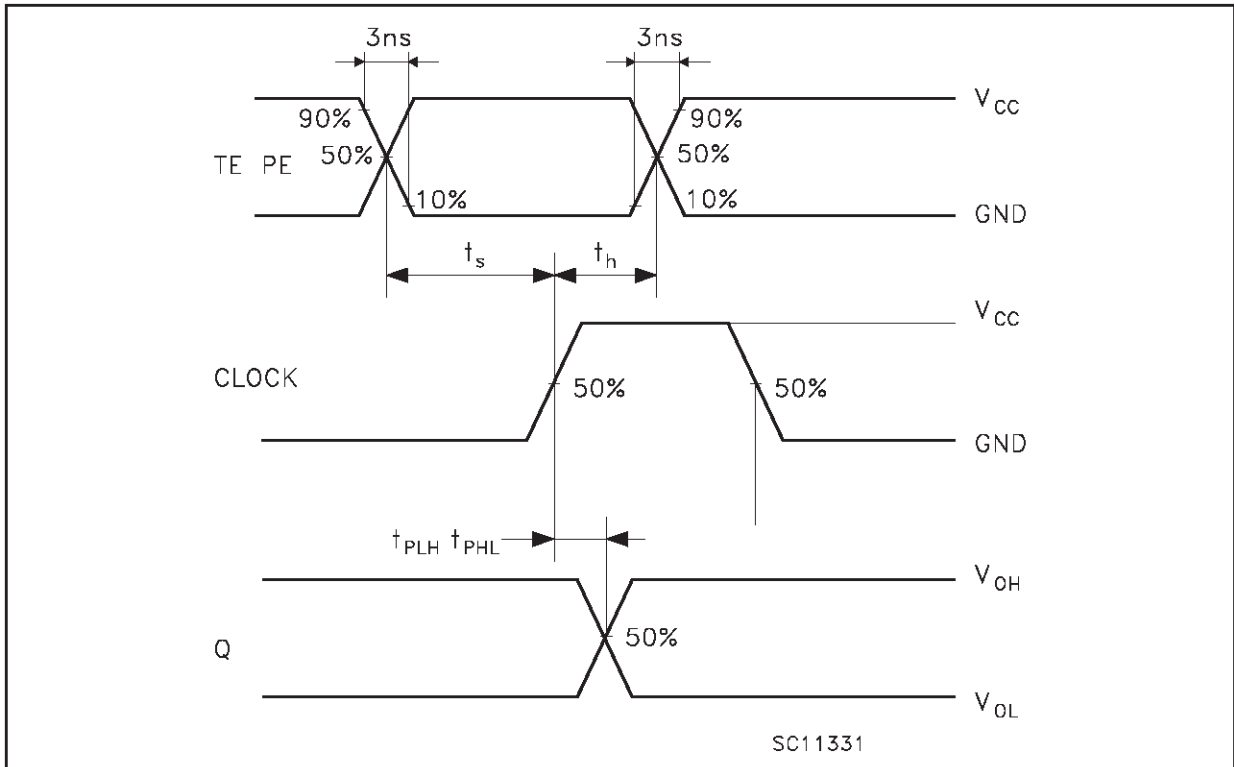

WAVEFORM 5: PROPAGATION DELAYS CASCADE MODE (f=1MHz; 50% duty cycle)

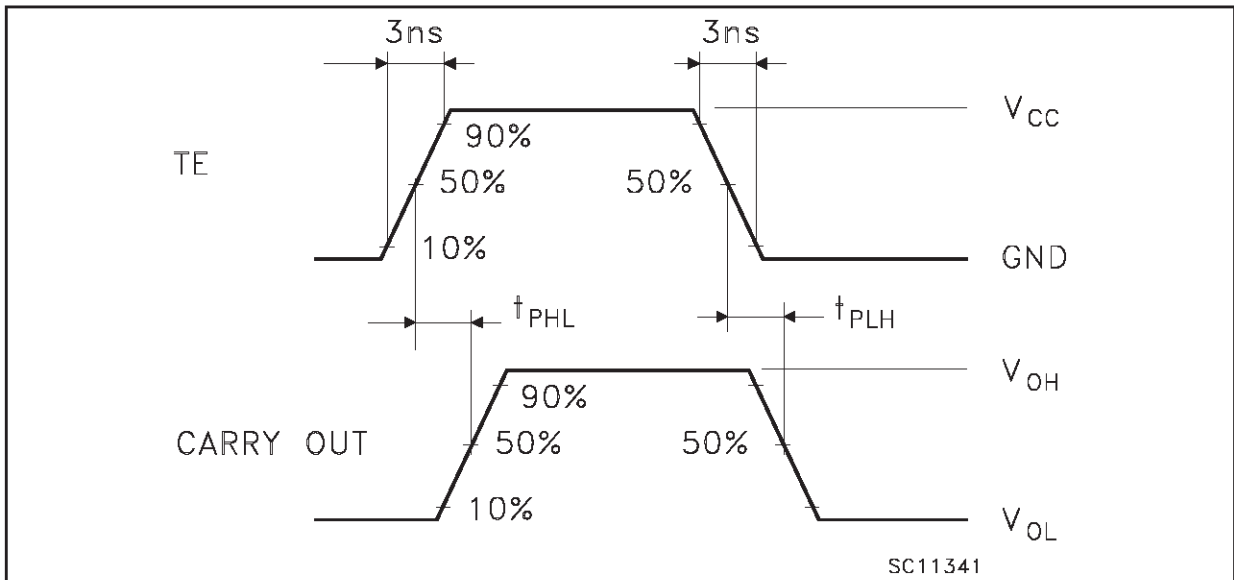

## SO-16 MECHANICAL DATA

DIM.	mm.			inch		
	MIN.	TYP.	MAX.	MIN.	TYP.	MAX.
A			1.75			0.068
a1	0.1		0.2	0.003		0.007
a2			1.65			0.064
b	0.35		0.46	0.013		0.018
b1	0.19		0.25	0.007		0.010
C		0.5			0.019	
c1	45° (typ.)					
D	9.8		10	0.385		0.393
E	5.8		6.2	0.228		0.244
e		1.27			0.050	
e3		8.89			0.350	
F	3.8		4.0	0.149		0.157
G	4.6		5.3	0.181		0.208
L	0.5		1.27	0.019		0.050
M			0.62			0.024
S	8° (max.)					

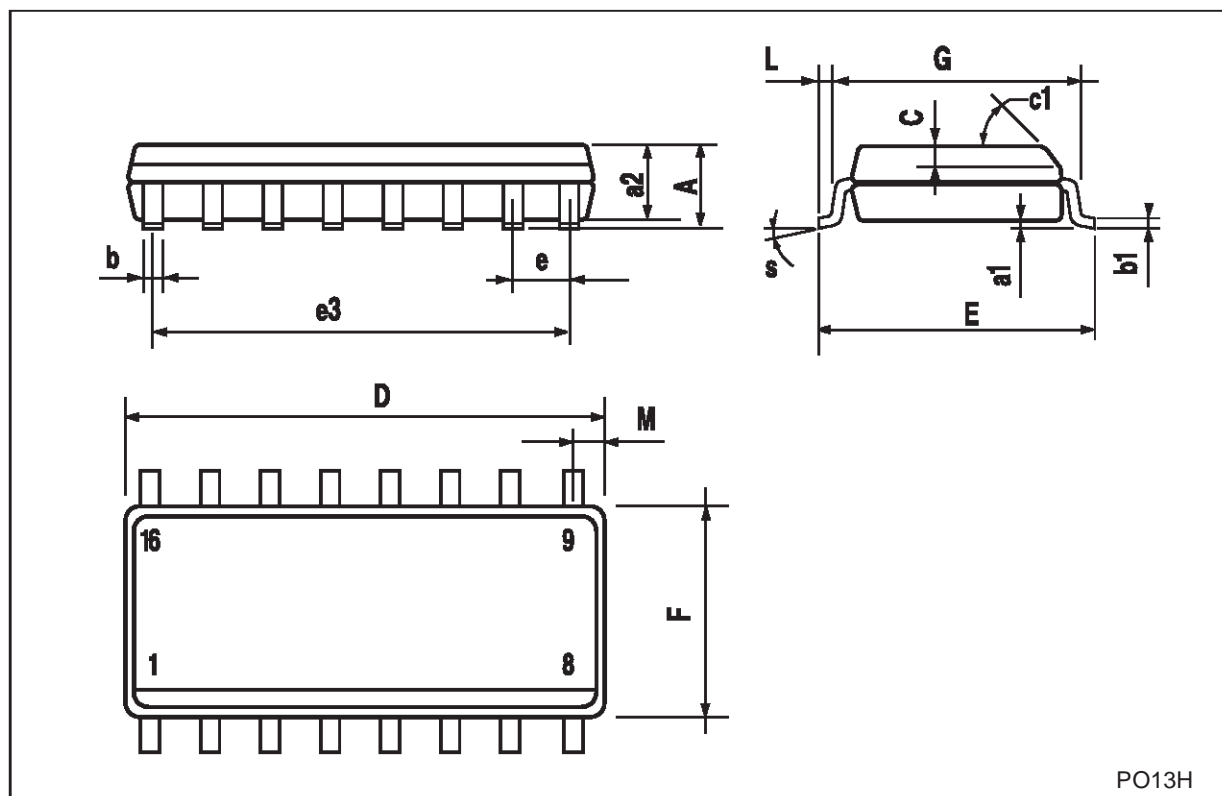

PO13H

## TSSOP16 MECHANICAL DATA

DIM.	mm.			inch		
	MIN.	TYP	MAX.	MIN.	TYP.	MAX.
A			1.2			0.047
A1	0.05		0.15	0.002	0.004	0.006
A2	0.8	1	1.05	0.031	0.039	0.041
b	0.19		0.30	0.007		0.012
c	0.09		0.20	0.004		0.0089
D	4.9	5	5.1	0.193	0.197	0.201
E	6.2	6.4	6.6	0.244	0.252	0.260
E1	4.3	4.4	4.48	0.169	0.173	0.176
e		0.65 BSC			0.0256 BSC	
K	0°		8°	0°		8°
L	0.45	0.60	0.75	0.018	0.024	0.030

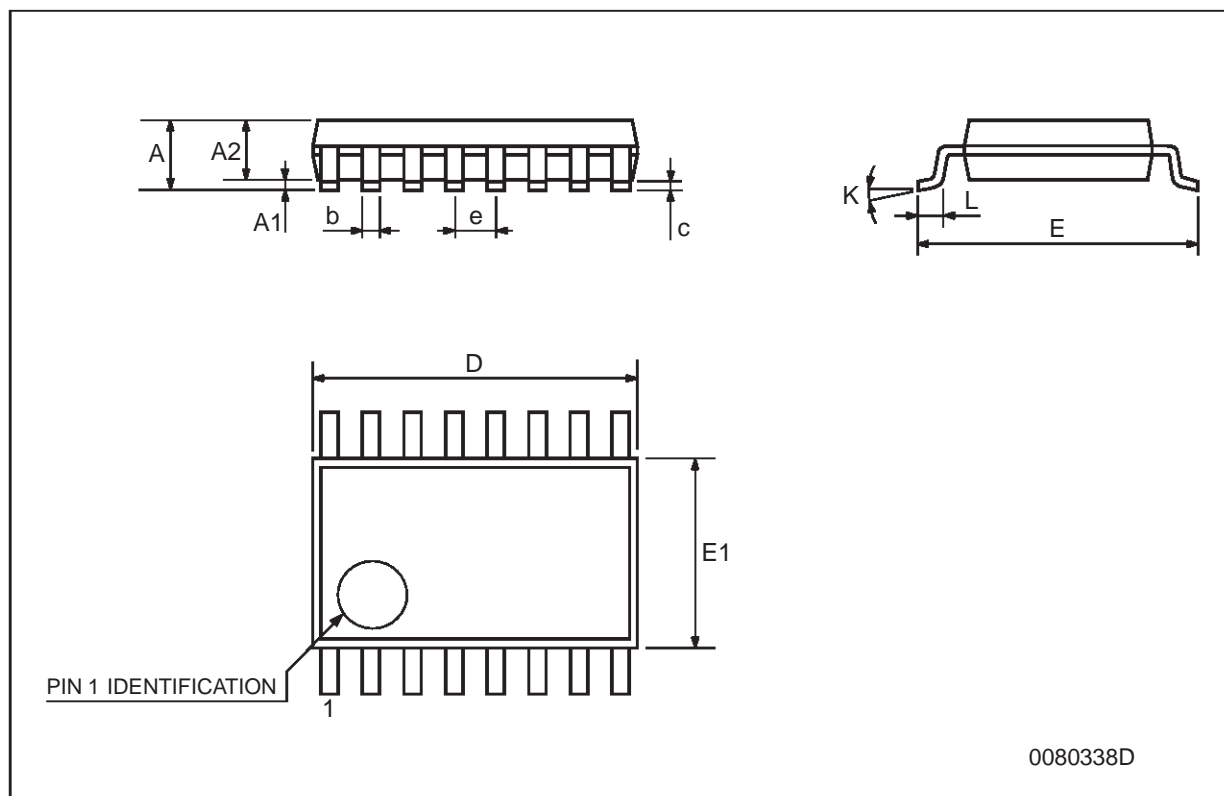

0080338D

Information furnished is believed to be accurate and reliable. However, STMicroelectronics assumes no responsibility for the consequences of use of such information nor for any infringement of patents or other rights of third parties which may result from its use. No license is granted by implication or otherwise under any patent or patent rights of STMicroelectronics. Specifications mentioned in this publication are subject to change without notice. This publication supersedes and replaces all information previously supplied. STMicroelectronics products are not authorized for use as critical components in life support devices or systems without express written approval of STMicroelectronics.

© The ST logo is a registered trademark of STMicroelectronics

© 2001 STMicroelectronics - Printed in Italy - All Rights Reserved  
STMicroelectronics GROUP OF COMPANIES

Australia - Brazil - China - Finland - France - Germany - Hong Kong - India - Italy - Japan - Malaysia - Malta - Morocco  
Singapore - Spain - Sweden - Switzerland - United Kingdom

© <http://www.st.com>

