

**SMALL SIGNAL SCHOTTKY DIODE**

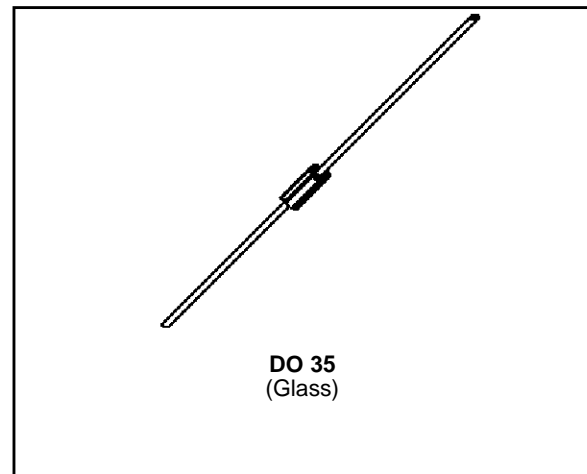

**DESCRIPTION**

Metal to silicon junction diode primarily intended for UHF mixers and ultrafast switching applications.

**ABSOLUTE RATINGS** (limiting values)

Symbol	Parameter		Value	Unit
$V_{RRM}$	Repetitive Peak Reverse Voltage		15	V
$I_F$	Forward Continuous Current	$T_a = 25^\circ\text{C}$	30	mA
$I_{FSM}$	Surge non Repetitive Forward Current	$t_p \leq 1\text{s}$	60	mA
$T_{stg}$ $T_j$	Storage and Junction Temperature Range		- 65 to +150 - 65 to +125	$^\circ\text{C}$ $^\circ\text{C}$
$T_L$	Maximum Temperature for Soldering during 10s at 4mm from Case		230	$^\circ\text{C}$

**THERMAL RESISTANCE**

Symbol	Test Conditions	Value	Unit
$R_{th(j-a)}$	Junction-ambient*	400	$^\circ\text{C}/\text{W}$

\* On infinite heatsink with 4mm lead length

## BAT 45

---

### ELECTRICAL CHARACTERISTICS

#### STATIC CHARACTERISTICS

Symbol	Test Conditions		Min.	Typ.	Max.	Unit
$V_{BR}$	$T_{amb} = 25^{\circ}C$	$I_R = 10\mu A$	15			V
$V_F$ (1)	$T_{amb} = 25^{\circ}C$	$I_F = 1mA$			0.38	V
	$T_{amb} = 25^{\circ}C$	$I_F = 10mA$			0.5	
	$T_{amb} = 25^{\circ}C$	$I_F = 30mA$			1	
$I_R$ (1)	$T_{amb} = 25^{\circ}C$	$V_R = 6V$			0.1	$\mu A$

#### DYNAMIC CHARACTERISTICS

Symbol	Test Conditions			Min.	Typ.	Max.	Unit
C	$T_{amb} = 25^{\circ}C$	$V_R = 1V$	$f = 1MHz$			1.1	pF
$\tau$	$T_{amb} = 25^{\circ}C$	$I_F = 20mA$	Krakauer Method			100	ps
F (2)	$T_{amb} = 25^{\circ}C$	$f = 1GHz$			6	7	dB

(1) Pulse test:  $t_p \leq 300\mu s$   $\delta < 2\%$ .

(2) Noise figure test :

- diode is inserted in a tuned stripline circuit
- local oscillator frequency 1GHz
- local oscillator power 1mW
- intermediate frequency amplifier, tuned on 300MHz, has a noise figure 1.5dB

Matched batches available on request. Test conditions (forward voltage and/or capacitance) according to customer specification.

Figure 1. Forward current versus forward voltage at different temperatures (typical values).

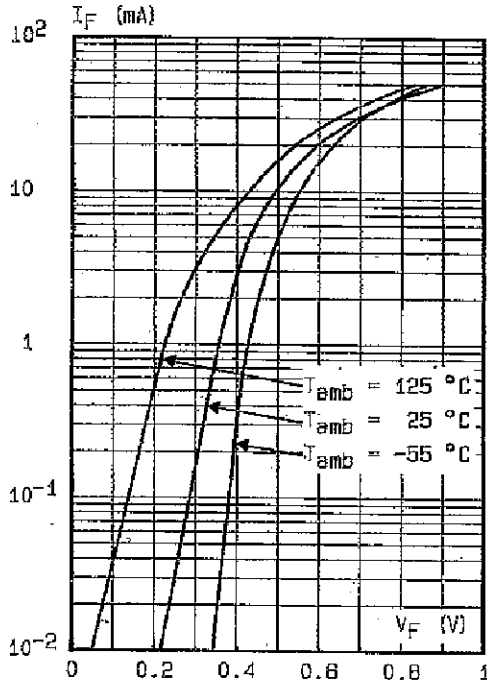

Figure 2. Forward current versus forward voltage (typical values).

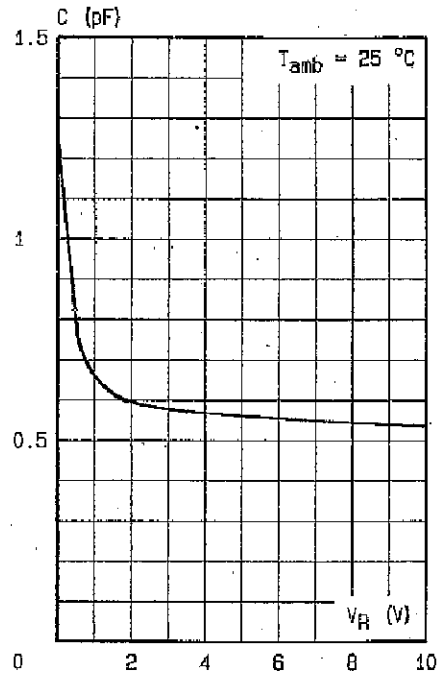

Figure 3. Reverse current versus junction temperature.

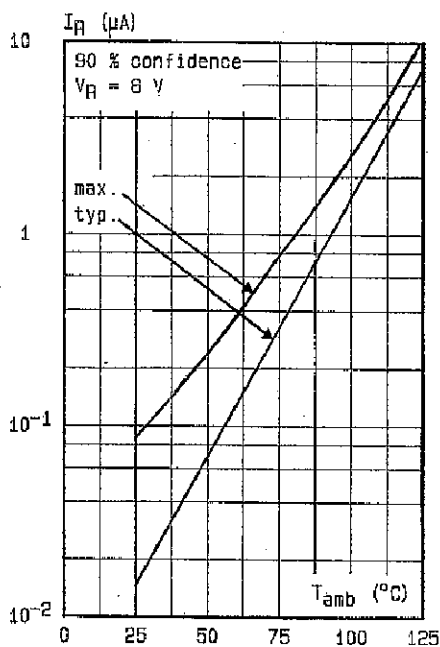
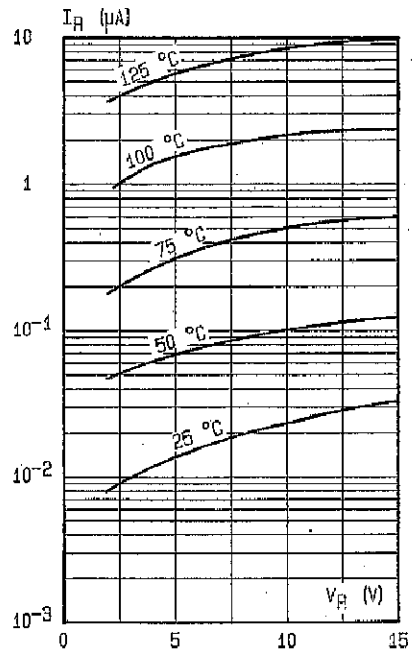

Figure 4. Reverse current versus continuous reverse voltage (typical values).



# BAT 45

## PACKAGE MECHANICAL DATA

DO 35 Glass

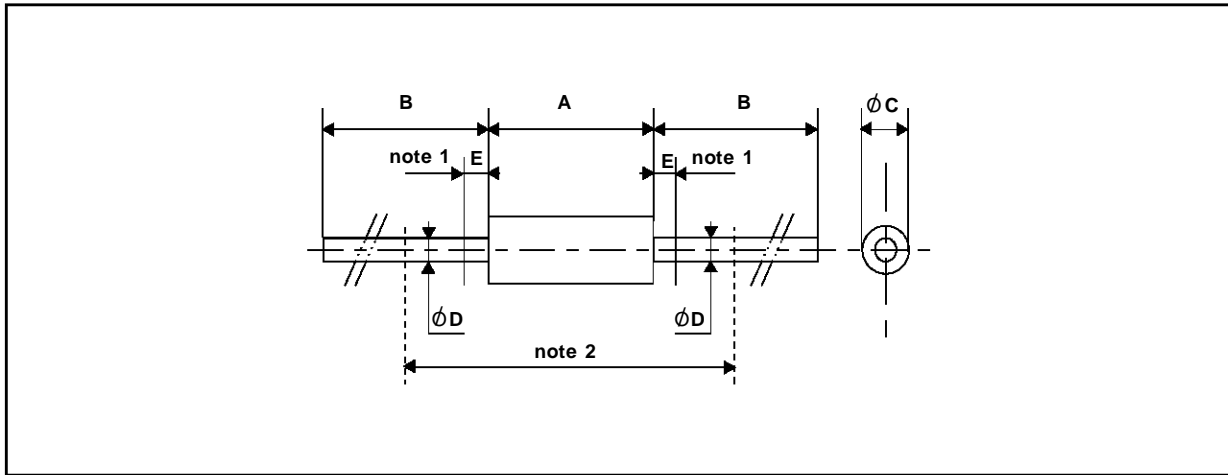

REF.	DIMENSIONS				NOTES
	Millimeters		Inches		
	Min.	Max.	Min.	Max.	
A	3.050	4.500	0.120	0.117	1 - The lead diameter $\varnothing D$ is not controlled over zone E 2 - The minimum axial length within which the device may be placed with its leads bent at right angles is 0.59" (15 mm)
B	12.7		0.500		
$\varnothing C$	1.530	2.000	0.060	0.079	
$\varnothing D$	0.458	0.558	0.018	0.022	
E		1.27		0.050	

Marking: clear, ring at cathode end.  
 Weight: 0.15g  
 Cooling method: by convection and conduction

Information furnished is believed to be accurate and reliable. However, SGS-THOMSON Microelectronics assumes no responsibility for the consequences of use of such information nor for any infringement of patents or other rights of third parties which may result from its use. No license is granted by implication or otherwise under any patent or patent rights of SGS-THOMSON Microelectronics. Specifications mentioned in this publication are subject to change without notice. This publication supersedes and replaces all information previously supplied. SGS-THOMSON Microelectronics products are not authorized for use as critical components in life support devices or systems without express written approval of SGS-THOMSON Microelectronics.

© 1994 SGS-THOMSON Microelectronics - Printed in Italy - All rights reserved.

SGS-THOMSON Microelectronics GROUP OF COMPANIES

Australia - Brazil - France - Germany - Hong Kong - Italy - Japan - Korea - Malaysia - Malta - Morocco - The Netherlands - Singapore - Spain - Sweden - Switzerland - Taiwan - United Kingdom - U.S.A.