

FEATURES

- 10-Bit, 1 kHz to 2.5 MSPS Analog-to-Digital Converter
- Monolithic CMOS
- Serial Output
- Internal Sample-and-Hold
- Analog Input Range: 0 to 2 V Nominal; 3.3 V Max
- Power Dissipation (Excluding Reference Ladder)
 - 45 mW at +5 V
 - 16 mW at +3.0 V
- Single Power Supply: +3 V to +5 V Range
- High ESD Protection: 3,000 V Minimum

APPLICATIONS

- Handheld and Desktop Scanners
- DSP Interface Applications
- Portable Digital Radios
- Portable and Handheld Applications
- Automotive Applications
- Remote Sensing

GENERAL DESCRIPTION

The SPT 10-bit, 2.5 MSPS, serial analog-to-digital converter delivers excellent high speed conversion performance with low cost and low power. The serial port protocol is compatible with the serial peripheral interface (SPI) or MICROWIRE™ industry standard, high-speed synchronous MPU interfaces. The large input bandwidth and fast transient response time allow for CCD applications operating up to 2.5 MSPS.

The device can operate with a power supply range from +3 V to +5 V with very low power dissipation. The small package size makes this part excellent for hand-held applications where board space is a premium. The SPT7830 is available in an 8-lead SOIC package over the commercial temperature range. Contact the factory for availability of die and industrial temperature range versions.

BLOCK DIAGRAM

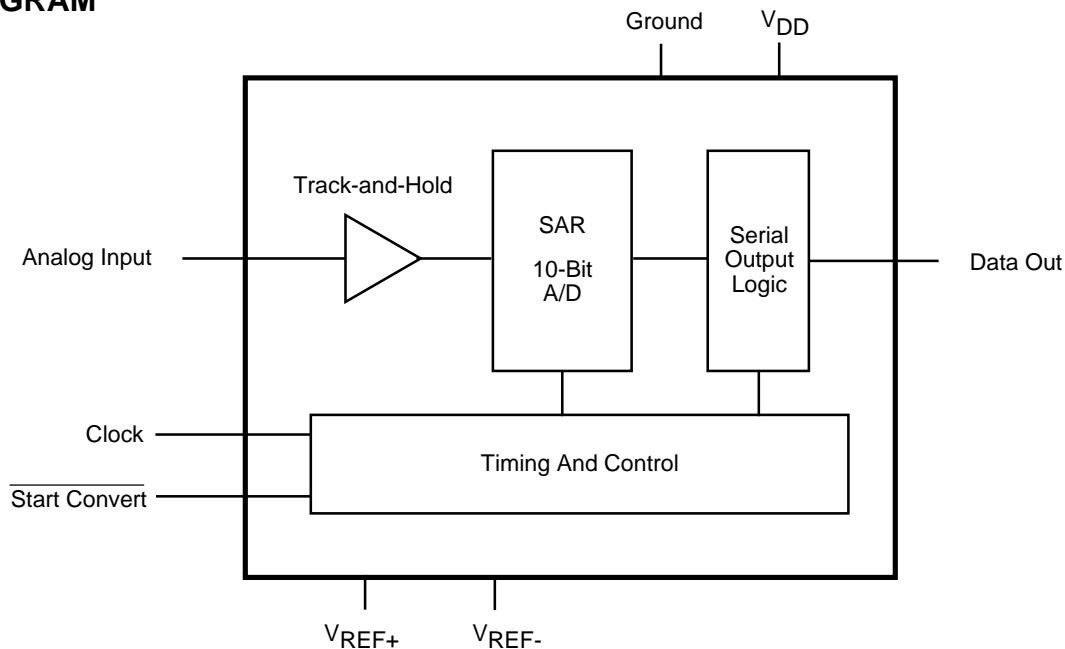

Signal Processing Technologies, Inc.

4755 Forge Road, Colorado Springs, Colorado 80907, USA

Phone: (719) 528-2300 FAX: (719) 528-2370

ABSOLUTE MAXIMUM RATING (Beyond which damage may occur)¹

Supply Voltages

V_{DD} +6 V

Output

Data Out 10 mA

Input Voltages

Analog Input -0.7 to +6 V
 V_{REF+} -0.7 to +6 V
 V_{REF-} -0.7 to +6 V
 Clock and \overline{SC} -0.7 to +6 V

Temperature

Operating, ambient 0 to +70 °C
 junction +175 °C
 Lead, Soldering (10 seconds) +300 °C
 Storage -65 to +150 °C

Note: 1. Operation at any Absolute Maximum Ratings is not implied. See Electrical Specifications for proper nominal applied conditions in typical applications.

ELECTRICAL SPECIFICATIONS

T_A = +25 °C, V_{DD} = +5.0 V, V_{IN} = 0 to +3 V, f_{CLK} = 35 MHz, f_S = 2.5 MSPS, V_{REF+} = +3.0 V, V_{REF-} = 0.0 V, unless otherwise specified.

PARAMETERS	TEST CONDITIONS	TEST LEVEL	MIN	TYP	MAX	UNITS
DC ELECTRICAL CHARACTERISTICS						
DC Performance						
Resolution				10		Bits
Differential Linearity		I		±0.5	±1.0	LSB
Integral Linearity		I		±1.0	±1.5	LSB
No Missing Codes		I		Guaranteed		
Analog Input						
Input Voltage Range ¹		IV	V _{REF-} +4%		V _{REF+} -6%	V
Input Resistance		I	5			MΩ
Input Capacitance		IV		5		pF
Input Bandwidth (Small Signal)		IV		30		MHz
Offset		IV	-2		+2	% of FSR
Gain Error		IV	-2		+2	% of FSR
Reference Input						
Resistance		IV	250	280	350	Ω
Voltage Range ¹						
V _{REF-} ²		IV	-4%	0	V _{REF+} -Δ	V
V _{REF+} ²		IV	V _{REF-} +Δ		2/3 V _{DD}	V
V _{REF+} -V _{REF-} (Δ)		IV	1/10 V _{DD}			V
Reference Settling Time		IV			90	ns
Timing Characteristics						
Maximum Conversion Rate		I	2.5	1.0		MSPS
Minimum Conversion Rate		IV	1			kSPS
Maximum External Clock Rate		I	35	14		MHz
Minimum External Clock Rate		IV	14			kHz
Aperture Delay Time		IV		5		ns
Aperture Jitter Time		IV		5		ps
Data Output LSB Hold Time	T _{MIN} to T _{MAX}	IV	6	8		ns

¹Percentages refer to percent of [(V_{REF+}) - (V_{REF-})]

²Δ = Minimum (V_{REF+} - V_{REF-})

ELECTRICAL SPECIFICATIONS

$T_A = +25\text{ }^\circ\text{C}$, $V_{DD} = +5.0\text{ V}$, $V_{IN} = 0\text{ to }+3\text{ V}$, $f_{CLK} = 35\text{ MHz}$, $f_S = 2.5\text{ MSPS}$, $V_{REF+} = +3.0\text{ V}$, $V_{REF-} = 0.0\text{ V}$, unless otherwise specified.

PARAMETERS	TEST CONDITIONS	TEST LEVEL	MIN	TYP	MAX	UNITS
Dynamic Performance						
Effective Number of Bits						
$f_{IN} = 500\text{ kHz}$		IV		8.9		Bits
$f_{IN} = 1\text{ MHz}$		IV		8.5		Bits
Signal-to-Noise Ratio						
$f_{IN} = 500\text{ kHz}$		IV		56		dB
$f_{IN} = 1\text{ MHz}$		IV		55		dB
Harmonic Distortion						
$f_{IN} = 500\text{ kHz}$		IV		63		dB
$f_{IN} = 1\text{ MHz}$		IV		58		dB
Power Supply Requirements						
+ V_{DD} Supply Voltage		IV	3		5.5	V
+ V_{DD} Supply Current	$V_{DD} = 3.0\text{ V}$	IV		5.4	7	mA
	$V_{DD} = 5.0\text{ V}$	I		9	10	mA
Power Dissipation ³	$V_{DD} = 3.0\text{ V}$	IV		16	22	mW
	$V_{DD} = 5.0\text{ V}$	I		45	50	mW

³Excluding reference ladder.

TEST LEVEL CODES

All electrical characteristics are subject to the following conditions:

All parameters having min/max specifications are guaranteed. The Test Level column indicates the specific device testing actually performed during production and Quality Assurance inspection. Any blank section in the data column indicates that the specification is not tested at the specified condition.

TEST LEVEL

TEST PROCEDURE

I	100% production tested at the specified temperature.
II	100% production tested at $T_A = 25\text{ }^\circ\text{C}$, and sample tested at the specified temperatures.
III	QA sample tested only at the specified temperatures.
IV	Parameter is guaranteed (but not tested) by design and characterization data.
V	Parameter is a typical value for information purposes only.
VI	100% production tested at $T_A = +25\text{ }^\circ\text{C}$. Parameter is guaranteed over specified temperature range.

GENERAL DESCRIPTION AND OPERATION

The SPT7830 is a 10-bit analog-to-digital converter that uses a successive approximation architecture to perform data conversion. Each conversion cycle is 14 clocks in length. When the Not Start Convert (\overline{SC}) line is held low, conversion begins on the next rising edge of the input clock. When the conversion cycle begins, the data output pin is forced low until valid data output begins.

The first two clock cycles are used to perform internal offset calibrations and tracking of the analog input. The analog input is then sampled using an internal track-and-hold amplifier on the falling edge of the third clock cycle. On clock cycles 4 through 14, a 10-bit successive approximation conversion is performed, and the data is output starting with the MSB.

Serial data output begins with output of the MSB. See the Data Output Timing section for details. Each bit of the data conversion is sequentially determined and placed on the data output pin at the clock rate. This process continues until the LSB has been determined and output. At this point, if the \overline{SC} line is high, the data output pin will be forced into a high impedance state, and the converter will go into an idle state waiting for the \overline{SC} line to go low. This is referred to as Single Shot Mode. See Modes of Operation for details.

If the \overline{SC} is either held low through the entire 14 clock conversion cycle (free run mode) or is brought low prior to the trailing edge of the fourteenth clock cycle (synchronous mode), the data output pin goes low and stays low until valid data output begins. Because the chip has either remained selected in the free run mode or has been immediately selected again in the synchronous mode, the next conversion cycle begins immediately after the fourteenth clock cycle of the previous conversion. See Modes of Operation for details.

TYPICAL INTERFACE CIRCUIT

CLOCK INPUT

The SPT7830 requires a 50% \pm 10% duty cycle clock running at 14 times the desired sample rate. The clock may be stopped in between conversion cycles without degradation of operation (single shot type of operation), however, the clock should remain running during a conversion cycle.

POWER SUPPLY

The SPT7830 requires only a single supply and operates from 3.0 V to 5.0 V. SPT recommends that a 0.01 μ F chip capacitor be placed as close as possible to the supply pin.

DATA OUTPUT SET UP AND HOLD TIMING

As figure 8 shows, all of the data output bits (except the LSB) remain valid for a duration equivalent to one clock period and delayed by 8 ns after the falling edge of clock. Because the data converter enters into a next conversion ready state at the leading edge of clock 14, **the LSB bit is valid for a duration equivalent to only the clock pulse width low and delayed**

by 8 ns after the falling edge of clock. Care should be taken to ensure that the LSB is latched into an external latch with the proper amount of set and hold time.

DATA OUTPUT CODING

The coding of the output is straight binary. (See table I.)

Table I - Data Output Coding

ANALOG INPUT	OUTPUT CODE D9 - DO		
+FS -1/2 LSB	1 1	1 1 1 1	1 1 1 \emptyset
+1/2 FS	\emptyset X	X X X X	X X X X
+1/2 LSB	00	0000	000 \emptyset
VREF-	00	0000	0000

\emptyset indicates the flickering bit between logic 0 and 1.
X indicates the flickering bit between logic 1 and 0.

ANALOG INPUT AND REFERENCE SETTling TRACK AND HOLD TIMING

Figure 9 shows the timing relationship between the input clock and \overline{SC} versus the analog input tracking and reference settling. The analog input is tracked from the fourteenth clock cycle of the previous conversion to the third clock cycle of the current conversion. On the falling edge of the third clock cycle, the analog input is held by the internal sample-and-hold. After this sample, the analog input may vary without affecting data conversion.

The reference ladder inputs (V_{REF+} and V_{REF-}) may be changed starting on the falling edge of the thirteenth clock cycle of the previous conversion and must be settled by the falling edge of the third clock cycle of the current conversion.

VOLTAGE REFERENCE AND ANALOG INPUT

The SPT7830 requires the use of a single external voltage reference for driving the high side of the reference ladder. The V_{REF+} can be a maximum of $2/3 V_{DD}$. For example, if $V_{DD} = +5$ V, then $V_{REF+} \text{ max} = (2/3) * 5 \text{ V} = +3.3 \text{ V}$. The lower side of the ladder is typically tied to AGND (0.0 V), but can be run up to a voltage that is 1/10th of V_{DD} below V_{REF+} :

$$V_{REF-} \text{ max.} = V_{REF+} - (1/10) * V_{DD}.$$

For example,
if $V_{DD} = +5$ V and $V_{REF+} = 3$ V, then
 $V_{REF-} \text{ max} = 3 \text{ V} - (1/10) * 5 \text{ V} = 2.5 \text{ V}$.

The +Full Scale (+FS) of the analog input is expected to be 6% of $[(V_{REF+}) - (V_{REF-})]$ below V_{REF+} and the -Full Scale (-FS) of the analog input is expected to be 4% of $[(V_{REF+}) - (V_{REF-})]$ above V_{REF-} . (See figure 1.)

Therefore,
Analog +FS = $V_{REF+} - 0.06 * [(V_{REF+}) - (V_{REF-})]$, and
Analog -FS = $V_{REF-} + 0.04 * [(V_{REF+}) - (V_{REF-})]$.

For example,
if $V_{REF+} = 3$ V and $V_{REF-} = 0$ V, then
Analog +FS = $3 \text{ V} - 0.06 * [3 \text{ V} - 0 \text{ V}] = 2.82 \text{ V}$, and
Analog -FS = $0 \text{ V} + 0.04 * [3 \text{ V} - 0 \text{ V}] = 0.12 \text{ V}$.

Figure 1 - Analog Input Full-Scale Range

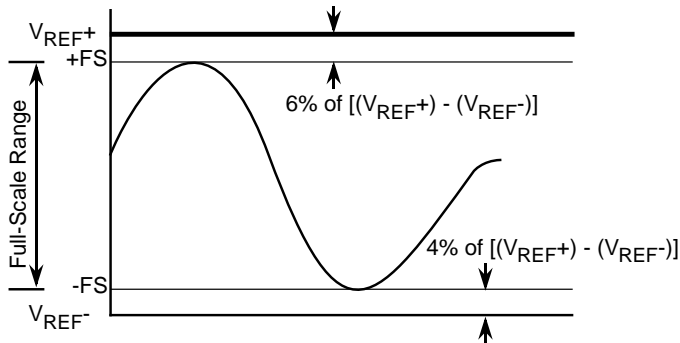

The drive requirements for the analog input are minimal when compared to most other converters due to the SPT7830's extremely low input capacitance of only 5 pF and very high input resistance of greater than 5 MΩ.

If the input buffer amplifier supply voltages are greater than $V_{DD} + 0.7\text{ V}$ or less than $\text{Ground} - 0.7\text{ V}$, the analog input should be protected through a series resistor and a diode clamping circuit as shown in figure 2.

Figure 2 - Recommended Input Protection Circuit

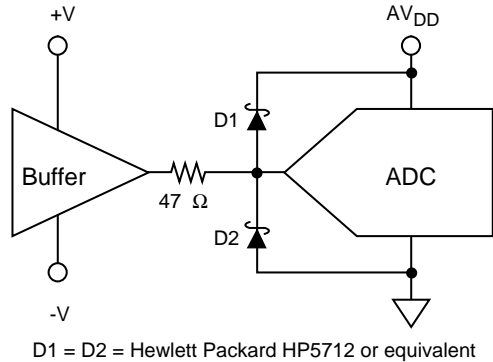

INPUT PROTECTION

All I/O pads are protected with an on-chip protection circuit shown in figure 3. This circuit provides ESD robustness to >3.0 kV and prevents latch-up under severe discharge conditions without degrading analog transition times.

Figure 3 - On-Chip Protection Circuit

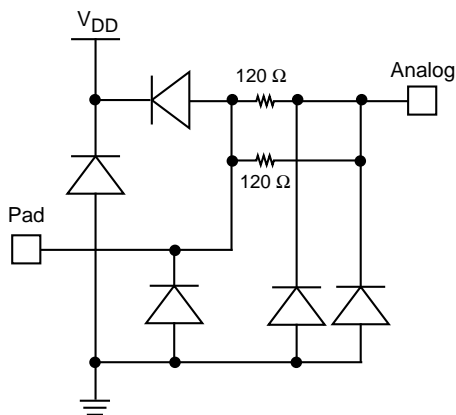

MODES OF OPERATION

The SPT7830 has three modes of operation. The mode of operation is based strictly on how the \overline{SC} is used.

SINGLE SHOT MODE

When \overline{SC} goes low, conversion starts on the next rising edge of the clock (defined as the first conversion clock). The MSB of data is valid 8 ns after the falling edge of the fourth conversion clock. (See figure 8, Data Output Timing.)

The conversion is complete after 14 clock cycles. At the falling edge of the fourteenth clock cycle, if \overline{SC} is high (not selected), the data output goes to a high impedance state, and no more conversions will take place until the next \overline{SC} low event. (See the single shot mode timing diagram in figure 4.)

SYNCHRONIZED MODE

When \overline{SC} goes low, conversion will start on the next rising edge of the clock (defined as the first conversion clock). The MSB is valid 8 ns after the falling edge of the fourth conversion clock.

The first conversion is complete after 14 clock cycles. At any time after the falling edge of the fourteenth clock cycle, \overline{SC} may go low again to initiate the next conversion. When the \overline{SC} goes low, the conversion starts on the rising edge of the next clock. (See the synchronized mode timing diagram in figure 5.)

The data output will go to a high impedance state until the next conversion is initiated.

FREE RUN MODE

When \overline{SC} goes low, conversion starts on the next rising edge of the clock (defined as the first conversion clock). The MSB data is valid 8 ns after the falling edge of the fourth conversion clock.

As long as \overline{SC} is held low, the device operates in the free run mode. New conversions start after every fourteenth cycle with valid data available 8 ns after the falling edge of the fourth clock within each new conversion cycle.

The data output remains low between conversion cycles. (See the free run mode timing diagram in figure 6.)

Figure 4 - Single Shot Mode Timing Diagram

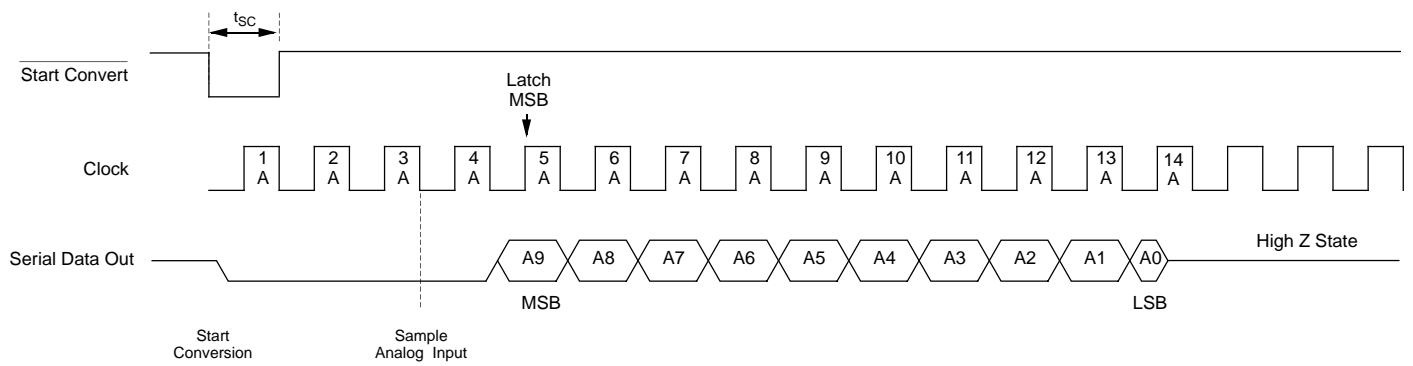

Figure 5 - Synchronous Mode Timing Diagram

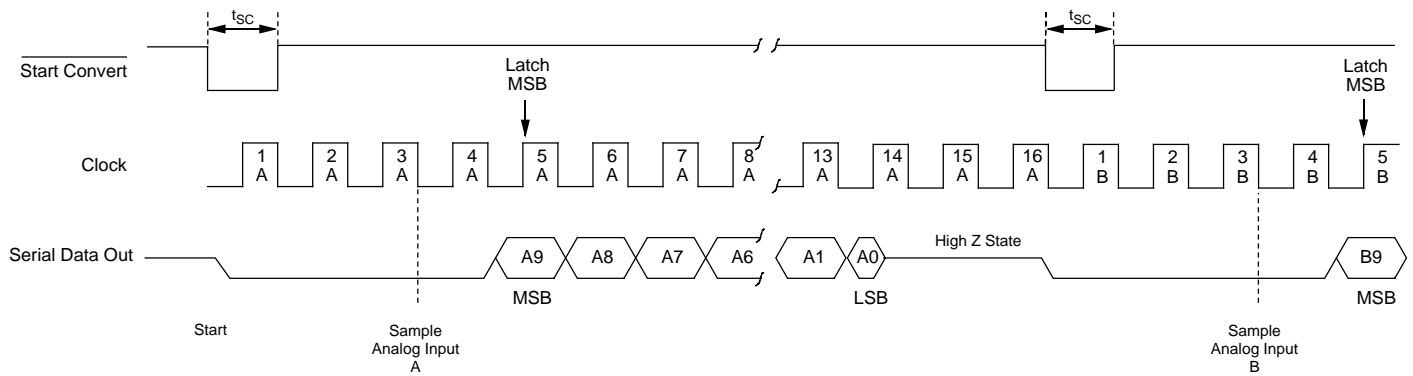

Figure 6 - Free Run Mode Timing Diagram

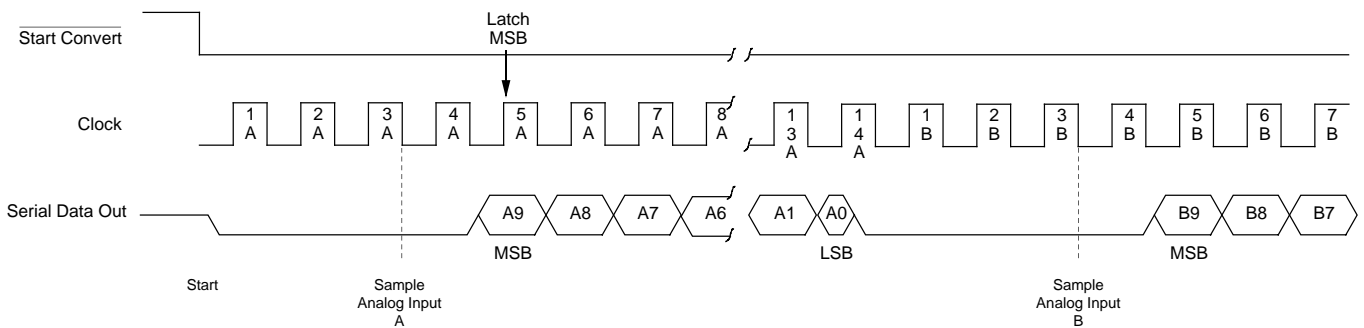

Figure 7 - Typical Interface Circuit

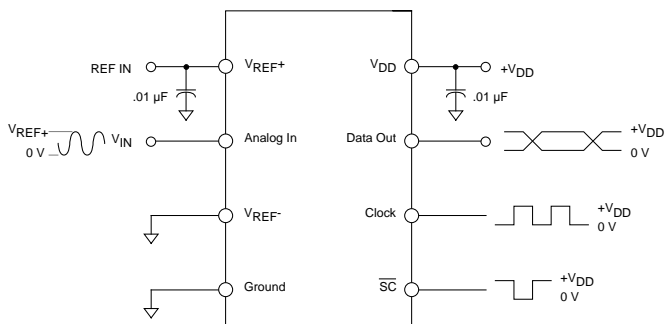

Figure 8 - Data Output Timing

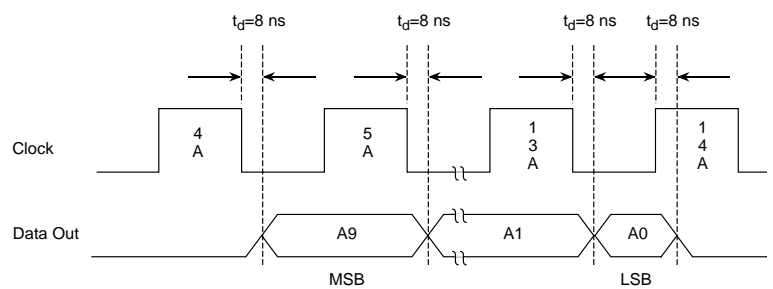
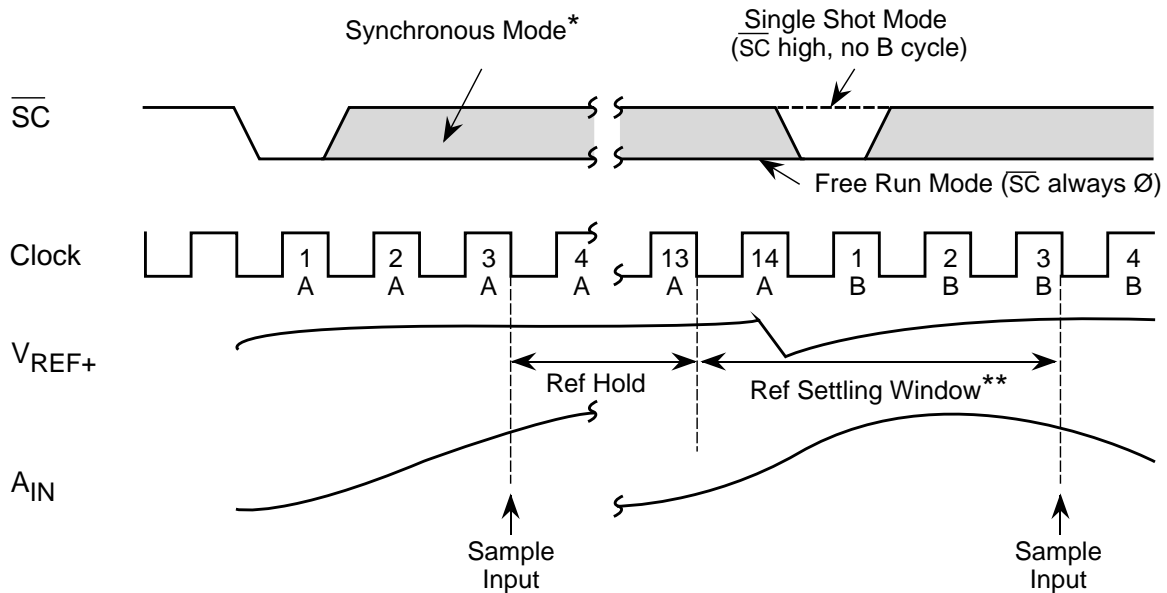

Figure 9 - Analog Input Track-and-Hold Timing and Reference Settling-and-Hold Timing



* The rising edge of the \overline{SC} line can occur any time between the rising edge of clock 1A and the falling edge of clock 14A.

** The reference settling window can be extended in the synchronous mode by adding extra clocks between conversion cycles. The example shown is the minimum number of clocks required (14) per conversion cycle.

PACKAGE OUTLINE

8-Lead SOIC

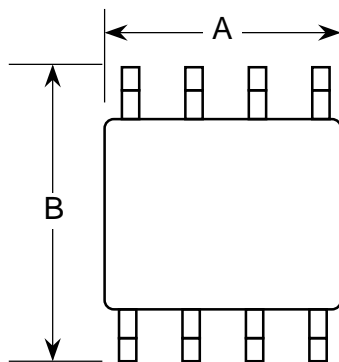

SYMBOL	INCHES		MILLIMETERS	
	MIN	MAX	MIN	MAX
A	0.187	0.194	4.80	4.98
B	0.228	0.242	5.84	6.20
C	0.050 typ		1.27 typ	
D	0.014	0.019	0.35	0.49
E	0.005	0.010	0.13	0.25
F	0.060	0.067	1.55	1.73
G	0.055	0.060	1.40	1.55
H	0.149	0.156	3.81	3.99
I	0°	8°	0°	8°
J	0.007	0.010	0.19	0.25
K	0.016	0.035	0.41	0.89

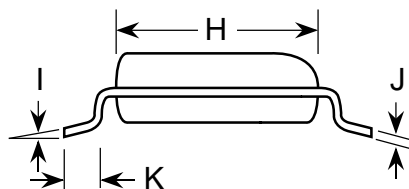
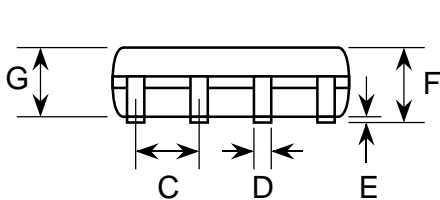

PIN ASSIGNMENTS

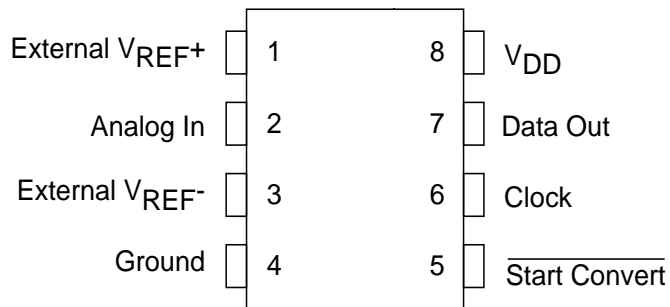

PIN FUNCTIONS

Name	Function
Analog In	Analog Signal Input
Start Convert	Start Convert. A high-to-low transition on this input begins the conversion cycle and enables serial data output.
Clock	Clock that drives A/D conversion cycle and the synchronous serial data output
Data Out	Serial Data. Tri-state serial data output for the A/D result driven by the CLOCK input
External V_{REF+}	External voltage reference for top of reference ladder
External V_{REF-}	External voltage reference for bottom of reference ladder
V_{DD}	Analog and Digital +3 V to +5 V Power Supply Input
GND	Analog and Digital Ground

ORDERING INFORMATION

PART NUMBER	TEMPERATURE RANGE	PACKAGE
SPT7830SCS	0 to +70 °C	8L SOIC
SPT7830SCU	+25 °C	Die*

*Please see the die specification for guaranteed electrical performance.

Covered by Patent Numbers 5262779 and 5272481.

Signal Processing Technologies, Inc. reserves the right to change products and specifications without notice. Permission is hereby expressly granted to copy this literature for informational purposes only. Copying this material for any other use is strictly prohibited.

WARNING - LIFE SUPPORT APPLICATIONS POLICY - SPT products should not be used within Life Support Systems without the specific written consent of SPT. A Life Support System is a product or system intended to support or sustain life which, if it fails, can be reasonably expected to result in significant personal injury or death.

Signal Processing Technologies believes that ultrasonic cleaning of its products may damage the wire bonding, leading to device failure. It is therefore not recommended, and exposure of a device to such a process will void the product warranty.