

Compensating for the 0 g Offset Drift of the ADXL50 Accelerometer

by Charles Kitchin and Paul Brokaw

INTRODUCTION

The ADXL50 accelerometer has a nominal sensitivity of 19 mV per g of applied acceleration. This is centered around a +1.8 volt offset. The offset will typically drift 35 mV over a 0 to +70 °C temperature range. This drift is very small compared with the amplitude of high g level signals but becomes more significant as the measured acceleration level decreases. For applications not needing a dc (i.e., gravity sensing) response, ac coupling between the preamplifier and the on-chip buffer amplifier will eliminate almost all of the 0 g drift. But, in cases where a dc response is needed, an external temperature compensation circuit will greatly improve the low g performance of the accelerometer.

This application note shows how to compensate for the linear component of the 0 g drift, using either a software or a hardware approach.

A Software Approach Using a μ P Interface

For those applications where the ADXL50 output drives a μ P, it can be used to subtract out the 0 g drift over temperature. This can be indirectly approximated by using the formula:

$$V_{0g} \text{ in } mV = ((1.3 \times 10^{-5}) T^3) + ((2.3 \times 10^{-3}) T^2) - (0.08 T) - 0.29$$

where T is the temperature in degrees centigrade, or by directly digitizing the output of a temperature sensor, using an ADC.

In the circuit of Figure 1, an AD590 temperature sensor and a 1 k Ω resistor are added to the board containing the accelerometer. The AD590 provides a 1 μ A/ $^{\circ}$ K current output which, together with the 1 k Ω resistor, provides a 1 mV/ $^{\circ}$ K output to the μ P. For best temperature tracking, the AD590 should be attached to the case of the ADXL50. The outputs of the ADXL50 and the AD590 both run to the μ P. The circuit is then placed in an oven and operated over temperature; the μ P then stores the drift curve in its memory and subtracts it out for all succeeding measurements.

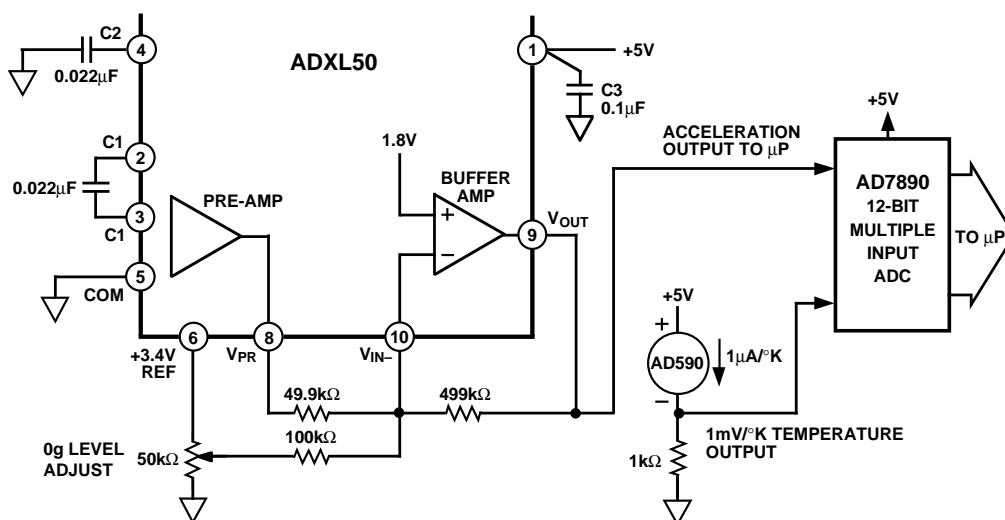

Figure 1. Acceleration & Temperature Outputs to μ P
for Software Correction of 0 g Drift

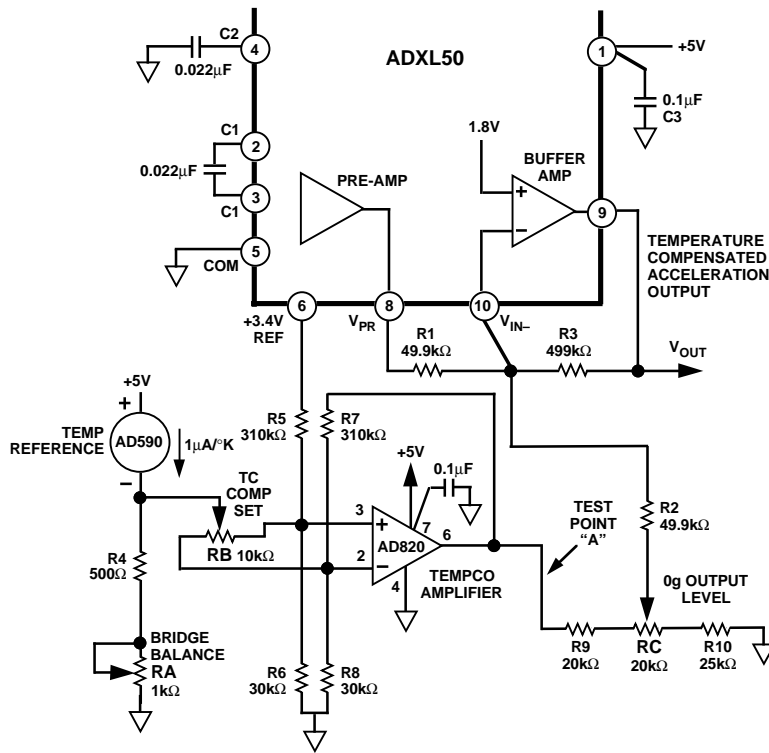

Figure 2. ADXL50 0 g Drift Compensation Circuit

A Hardware Approach

The circuit of Figure 2 provides a linear temperature compensation for the ADXL50. Figure 3 shows the 0 g drift over temperature for a typical ADXL50 with and without this circuit. As shown by Figure 3, the linear portion of the drift curve has been subtracted out. In effect, the curve has been rotated counter clockwise until it is horizontal, leaving just the bow of the curve: that portion which is not linear.

As shown in Figure 3, over a +25 °C to +70 °C range, a 10× reduction in drift is achieved. The circuit of Figure 2 is essentially a temperature sensor coupled to a forced-balance bridge. The AD590 provides a 1 µA/°K current output whose voltage scale factor is set by resistor RA. The bridge circuit subtracts out the nominal 298 mV output of the AD590 at +25 °C and leaves only the change in temperature, which is what is needed.

Resistors R5 and R6 form a resistor divider (one half of the bridge) which divides down the +3.4 V reference output of the ADXL50 to 0.3 V which appears at the noninverting input of the AD820 op amp. Resistors R7 and R8 form the other half of the bridge, and because they have the same ratio as R5 and R6 the op amp will have a +3.4 V output at room temperature. Therefore, the op amp is across the output of the bridge and any imbalance will cause its output to change enough to maintain the summing junction at 0.3 V, which keeps the bridge in balance.

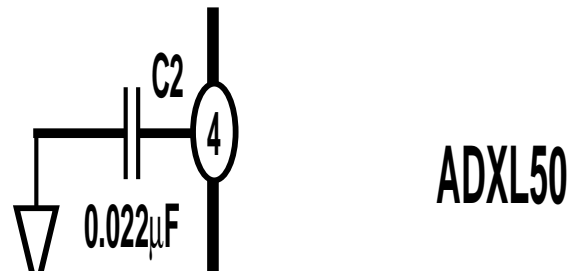

Figure 3. ADXL50 0 g Drift With & Without the Compensation Circuit of Figure 2

The output from the AD590 connects to the wiper of trim potentiometer R B. Since RB is across the input terminals of the op amp, the circuit can provide a variable output with temperature in either the positive or negative direction. The op amp output is divided down by resistors R9 and R10 which limit the range of trim potentiometer RC and increase its resolution. Resistors R1 and R3 set the ADXL50 accelerometer's gain at ten (190 mV/g) which is appropriate at low g levels, while R2 and R3 set the gain of the compensation circuit.

CALIBRATION PROCEDURE:

AT T_{MIN} OR LOWER TEMP CAL. POINT:

1. SET RB ALL THE WAY TO ONE SIDE.
2. ADJUST RA FOR +3.4V AT TEST POINT "A."
3. SET RC FOR +2.5V V_{OUT} (AT PIN 9 OF ADXL50).

TO TEST THE CIRCUIT:

4. TEMPORARILY CONNECT A 1.5kΩ RESISTOR BETWEEN THE WIPER OF RB AND COMMON.
5. ADJUST RB FOR +2.5V AT V_{OUT} .
6. REMOVE THE 1.5kΩ RESISTOR. V_{OUT} SHOULD NOT CHANGE.

AT T_{MAX} OR UPPER TEMP CAL. POINT:

7. GO TO T_{MAX} OR HIGH TEMP CAL. POINT.
8. READJUST RB FOR +2.5V @ V_{OUT} .
9. CALIBRATION COMPLETE.