

Acceleration to Frequency Circuits

by Charles Kitchin, Dave Quinn, and Steve Sherman

INTRODUCTION

Low cost monolithic accelerometers may be paired with a circuit whose output changes with frequency (V/F) to provide a TTL level frequency output. A microprocessor can be easily programmed to read this signal and directly compute the applied acceleration, and the output of a V/F circuit can be sent down a long transmission line and still be reliably recovered at the other end.

A High Performance Acceleration-to-Frequency Circuit

A circuit whose output frequency varies directly with applied acceleration is shown in Figure 1. The circuit operates from a single +9 V or +12 V power supply.

An ADXL05, $\pm 5 g$ accelerometer directly converts any applied acceleration into an analog output voltage which then controls the output frequency of an AD654 low cost voltage-to-frequency converter IC. The frequency output appears at Pin 1 of the AD654. Total chip cost for this circuit is approximately \$20.00 (in 1000s).

The voltage output at Pin 8 of the ADXL05 is +2.5 volts with no acceleration and varies 200 mV above or below that value for each 1 g (positive or negative) of applied acceleration.

0g FREQ	SF	C _T	R ₁	R ₂	R ₃
Hz	Hz/g	μF	kΩ	kΩ	kΩ
10	10	10	14.7	464	182
100	10	1	40.2	127	49.9
100	100	1	14.7	464	182
1000	10	0.1	133	42.2	16.5
1000	100	0.1	40.2	127	49.9
1000	1000	0.1	14.7	464	182
10,000	10	0.01	1370	43.2	16.9
10,000	100	0.01	137	43.2	16.9
10,000	1000	0.01	40.2	127	49.9
100,000	10	0.001	137	0.43	0.169
100,000	100	0.001	137	4.32	1.69
100,000	1000	0.001	137	43.2	16.9

DESIGN EQUATIONS

$$0g \text{ FREQUENCY} = \frac{0.25}{R_T C_T}$$

$$\text{SCALE FACTOR (Hz/g)} = \frac{\Delta \text{FREQ}}{g} = \frac{200 R_3}{1000 R_1 R_T C_T}$$

$$3\text{dB ACCELERATION BW} = \frac{1}{2\pi R_3 C_5}$$

$$R_2 \text{ FOR A } +2.5V \text{ } 0g \text{ LEVEL} = 2.57 R_3$$

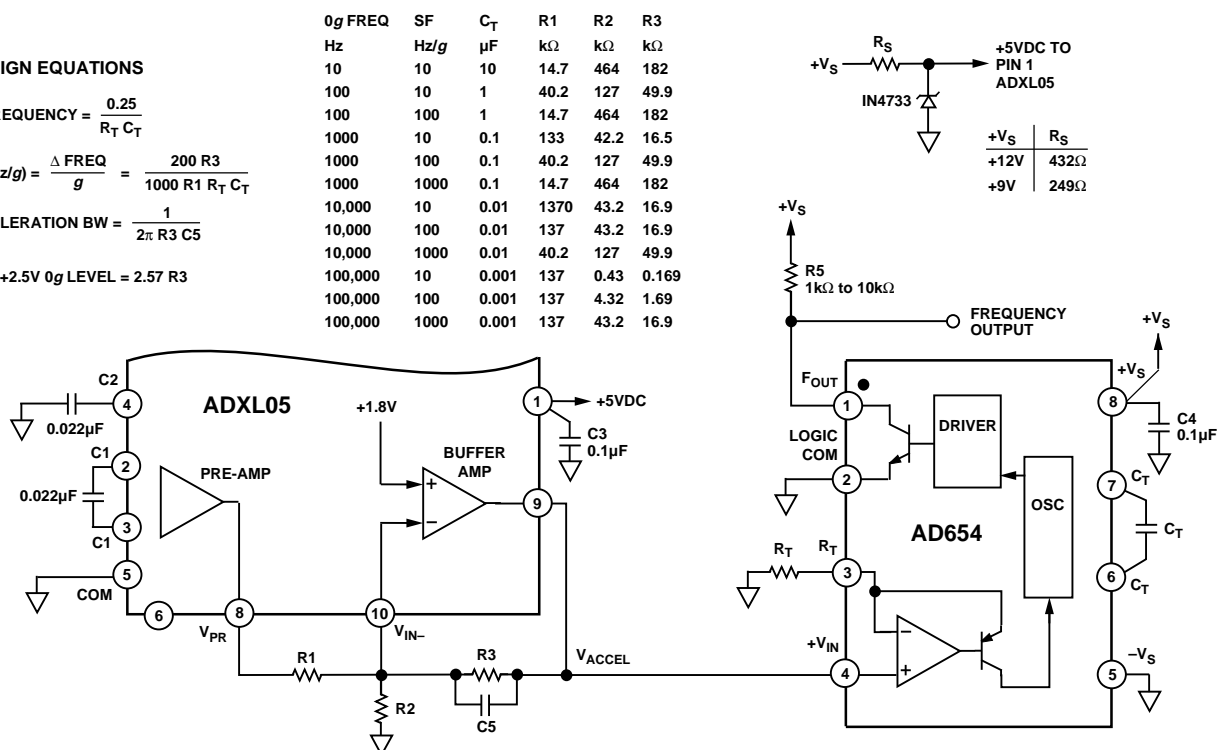

Figure 1. A High Performance Acceleration-to-Frequency Circuit

The output scale factor of the accelerometer (at Pin 9) is set by the resistors R3 & R1 of the on-chip buffer amplifier. Resistor R2 is used to change the 0 g output level to a convenient +2.5 V (which provides the maximum output voltage swing). Capacitor C5 and Resistor R3 form a low-pass filter which improves the circuit's signal-to-noise ratio.

Figure 2 shows the same circuit modified for use with the ADXL50, a ±50 g accelerometer. The accelerometer's 3 dB bandwidth is again set by R3 & C5. In Figure 2, both a zero g offset and a scale factor trim potentiometer have been added to allow the user to adjust the circuit to extremely high accuracy; trim potentiometers may also be added to the circuit of Figure 1. R1a should be approximately 50% the value of R1b (for a ±20% trim range). Note: for the best mechanical stability the trim potentiometers should be measured (after calibration is complete) and replaced with 1% resistors.

Design example: Circuit of Figure 2

Design example: Wanted . . . 0 g frequency = 10 kHz,
Scale Factor = 100 Hz/g, BW = 200 Hz.

A 50 g signal will cause a frequency variation of 5 kHz.

Therefore:

$$F_{OUT} \text{ for } \pm 50 \text{ g} = 10 \text{ kHz} \pm 5 \text{ kHz} = 5 \text{ kHz} - 15 \text{ kHz}$$

Let $C_T = 0.01 \mu\text{F}$, then for a 0 g frequency of 10 kHz:

$$R_T = \frac{0.25}{10 \text{ kHz } C_T} = 2.5 \text{ k}\Omega$$

Let $R_3 = 49.9 \text{ k}\Omega$, for a scale factor of 100 Hz/g:

$$R_1 = \frac{19 \text{ mV/g} \times R_3}{100 \text{ Hz/g } 10,000 R_T C_T} = 52.7 \text{ k}\Omega$$

For R_1 , use a 42.2 kΩ fixed resistor & a 20 kΩ trim potentiometer.

For a 200 Hz bandwidth:

$$C_5 = \frac{1}{2\pi \cdot 200 \cdot R_3} = 0.016 \mu\text{F}$$

The accelerometer may be self-calibrated by using the Earth's gravity. With the accelerometer's tab pointed 90° to the vertical (i.e., to either side), the accelerometer will measure 0 g, allowing the 0 g offset to be adjusted. With the accelerometer's tab pointing down, its output at Pin 9 will correspond to +1 g. If the accelerometer is rotated 180° it will then measure -1 g. The 2 g difference in the readings can then be used to set the circuit's over-

0g FREQ	SF	C_T	R1a	R1b	R2	R3
Hz	Hz/g	μF	kΩ	kΩ	kΩ	kΩ
10	10	10	5	12.1	100	2MΩ
100	10	1	10	34.8	100	499
100	100	1	5	12.1	100	2MΩ
1000	10	0.1	50	107	100	165
1000	100	0.1	10	34.8	100	499
1000	1000	0.1	5	12.1	100	2MΩ
10,000	10	0.01	500	1MΩ	100	169
10,000	100	0.01	50	107	100	169
10,000	1000	0.01	10	34.8	100	499
100,000	10	0.001	50	107	100	1.69
100,000	100	0.001	50	107	100	16.9
100,000	1000	0.001	50	107	100	169

DESIGN EQUATIONS

$$0g \text{ FREQUENCY} = \frac{0.25}{R_T C_T}$$

$$\text{SCALE FACTOR (Hz/g)} = \frac{\Delta \text{FREQ}}{g} = \frac{19 R_3}{1000 R_1 R_T C_T}$$

$$3dB \text{ ACCELERATION BW} = \frac{1}{2\pi R_3 C_5}$$

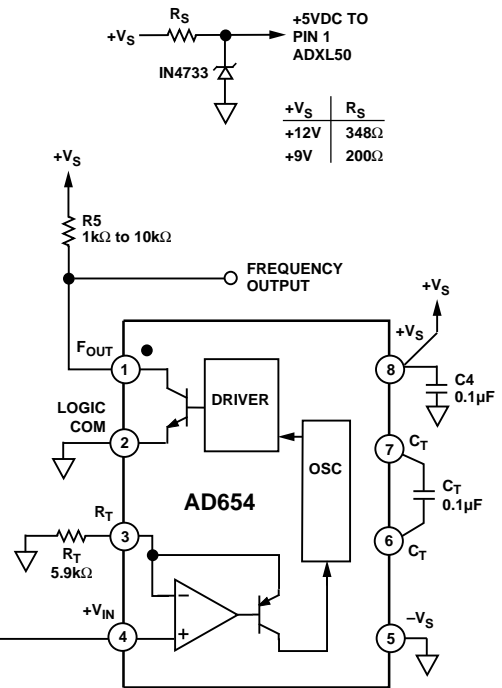
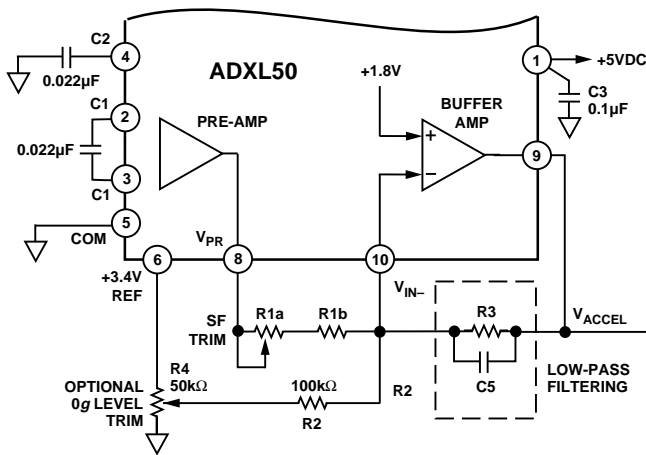

Figure 2. A ±50 g Acceleration-to-Frequency Circuit

all scale factor. The 0 g & full-scale frequency adjustments should be repeated a couple of times to get the highest accuracy.

An Accelerometer Tilt Sensor with a Frequency Output

Figure 3 shows how an ADXL05 accelerometer can be connected to a low cost CMOS 555 timer to provide a frequency output. The component values indicated were selected for a $\pm 1 g$ tilt application.

The nominal 200 mV/g output of the accelerometer appears at Pin 8 and is gained-up by a factor of 2 to a 400 mV/g level by the onboard buffer amplifier. The 0 g bias level at Pin 9 is approximately 1.8 V. Capacitor C4 and Resistor R3 form a 16 Hz low-pass filter to lower noise and improve the measurement resolution.

The CMOS 555 operates as a voltage controlled oscillator where R5, R6, and C5 set the nominal operating frequency where R5, R6, and C5 set the nominal operating frequency. Resistors R5 & R6 were chosen to give an approximate 50% duty cycle with a +1.8 V (0 g) input signal applied to Pin 5 of the 555. To prevent any change in frequency due to supply variations, the 555 operates from the accelerometer's +3.4 V reference rather than directly off the +5 V supply.

The output frequency of this circuit is determined by the charge and discharge times set by R5, R6, and C5.

Using the circuit and component values shown in Figure 3, the output scale factor at Pin 9 of the accelerometer will be $\pm 400 \text{ mV/g}$ so the voltage output will be $+1.8 \text{ V} \pm 0.4 \text{ V}$. The output scale factor at Pin 3 of the 555 will be approximately $16,500 \text{ Hz} \pm 2,600 \text{ Hz per } g$. Figure 4 shows the circuit's output frequency vs. the voltage occurring at Pin 5 of the 555.

Frequency stability of this circuit is quite good. With a 15.5 kHz 0 g frequency, the measured 0 g frequency drift over the 0°C to $+70^\circ\text{C}$ commercial temperature range was $5 \text{ Hz}/^\circ\text{C}$ which is $0.03\%/^\circ\text{C}$. The change in frequency vs. supply voltage is less than 10 Hz with a +5.0 volt to +9.0 volt supply range.

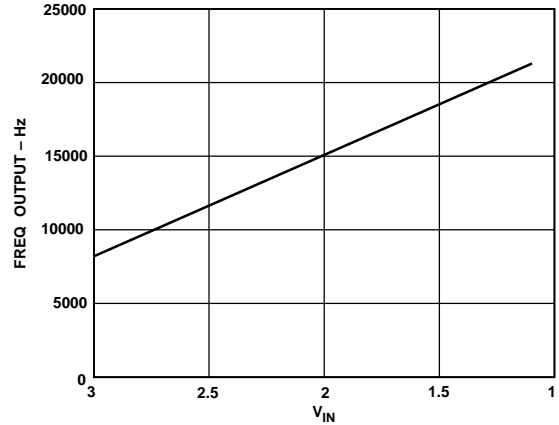

Figure 4. Frequency Output vs. Voltage Input for the Circuit of Figure 3

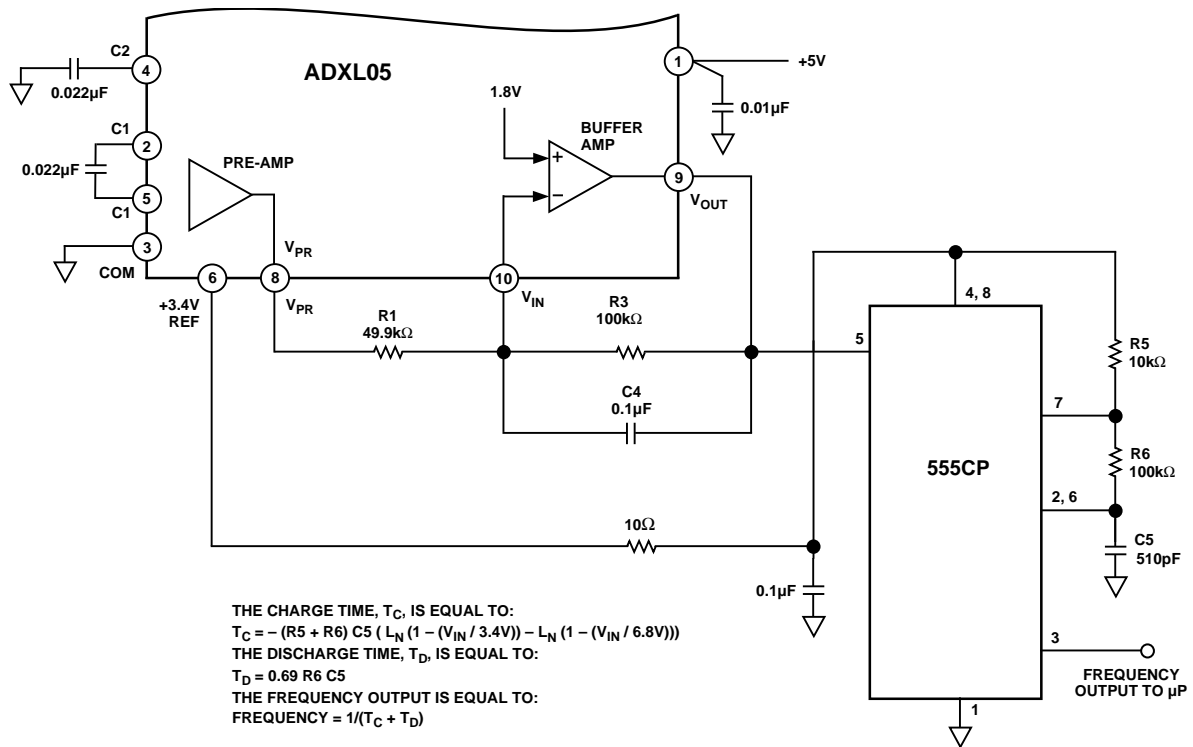

Figure 3. A Low Cost Accelerometer Tilt Sensor with a Frequency Output

