

10/100Mbps Ethernet Controller

General Description

TOSHIBA's TC35815CF is a high-speed 10/100BaseX CSMA/CD Local Area Network (LAN) Media Access Controller (MAC) for both the IEEE 802.3u / 802.3x 10Mbps ETHERNET and 100Mbps Fast ETHERNET standards. It provides a highly integrated and cost-effective ETHERNET solution for PC motherboards and Network Interface Cards (NIC), as well as embedded applications such as printers, LAN-ATM bridges, routers and hubs.

By supporting a direct connection to the 32-bit Peripheral Components Interconnect (PCI) Local Bus, the TC35815CF can be used with a physical layer device to provide a low cost solution. The controller uses burst transfer mode and a receive packing mode to efficiently move data to and from system memory. On-chip memory for buffering eliminates the need for external local buffer memory in NICs.

By keeping the MAC layer and CSMA/CD protocol unchanged, network administrators can quickly adapt newer and faster implementations. This approach also lowers cost of deployment, since it allows re-use of existing applications software. By supporting both 10Mbps and 100Mbps speeds, new products may be deployed into markets, which are in transition.

Features

- 10/100Mbps CSMA/CD MAC Controller (IEEE 802.3u)
- Media Independent Interface (MII) for 10/100Mbps
- IEEE 802.3x Flow Control
- 7-Wire Interface for low cost PHY controller 32-bit / 33MHz
- PCI Local Bus Interface requires no glue logic
- On-chip buffers eliminate the need for local memory
- Independent transmit and receive paths provide full-duplex operation
- On-chip processing of software queues reduces processor interrupts
- Buffer chaining supports scatter-gather DMA mode
- Large, on-chip CAM reduces processor and memory load
- External CAM Interface supports large CAM capability for bridges and routers
- 3.3V power supply (5Vtolerant inputs)
- Low power 0.3µm CMOS process (typically 50mA @ 3.3V / 33MHz)
- 0 +70 temperature range
- 144-pin QFP package

Block Diagram

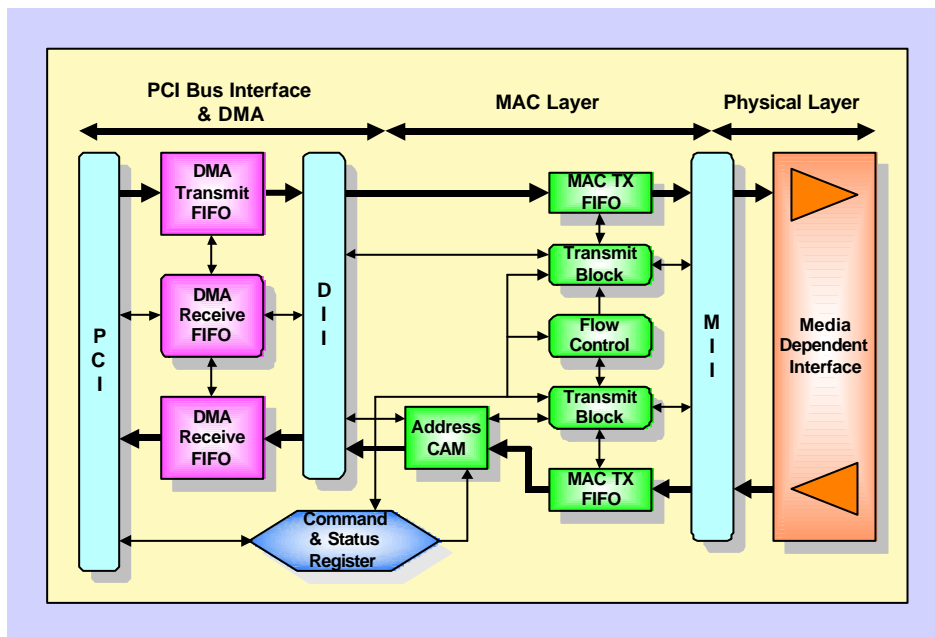

10/100Mbps Ethernet Controller**Applications**

- PC Motherboards
- Network Interface Cards
- Embedded applications
 - Printers, LAN-ATM bridges, Routers, Hubs

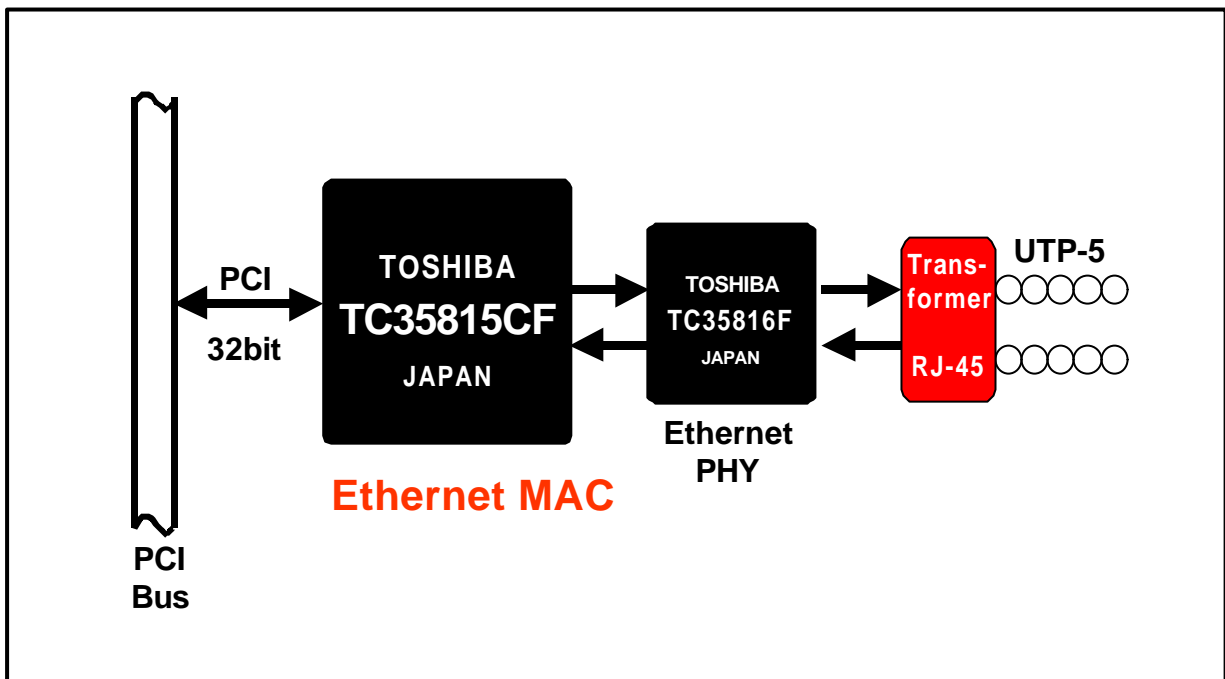
Application Examples**Demo board supporte NOS Software:**

- Netware ODI driver, Ver1.10, for DOS
- NDIS2.01 driver, Ver1.10, for Windows For Workgroups Ver3.11
- Packet driver, Ver1.10, for PC/TCP
- Netware ODI driver, Ver1.10, for OS2
- NDIS2.01 driver, Ver1.10 for OS2
- Netware ODI driver, Ver1.10, for Novell Server
- NDIS3.0 Miniport driver, Ver1.10, for Win95/NT

Copyright (C)1999 TOSHIBA CORPORATION. All Rights Reserved.

CAUTION

The information contained herein is presented only as a guide for the applications of our products. No responsibility is assumed by TOSHIBA CORPORATION for any infringements of intellectual property or other rights of third parties which may result from its use. Neither the implication nor any other use of the information contained in this document shall constitute an assignment of, or an agreement to assign, or a license of any Intellectual Property Rights of TOSHIBA CORPORATION or others.
The products described in this document are subject to trade laws and exchange and export control regulations.