

TOSHIBA BIPOLAR LINEAR INTEGRATED CIRCUIT SILICON MONOLITHIC

TA8162SN**DUAL PREAMPLIFIER**

The TA8162SN is dual preamplifier designed for car stereo tape deck.

This IC contains dual preamplifier and metal/normal tape equalizer control switches.

FEATURES

- High Open Loop Voltage Gain
: $G_{VO} = 98\text{dB}$ (Typ.) ($V_{CC} = 9\text{V}$, $f = 1\text{kHz}$)
- Low Distortion
: $\text{THD} = 0.035\%$ (Typ.) ($G_V = 40\text{dB}$, $f = 1\text{kHz}$, $V_{OUT} = 0.5V_{\text{rms}}$)
- Low Noise (Equivalent Input Noise Voltage)
: $V_{NI} = 0.9\mu\text{V}_{\text{rms}}$ (Typ.)
($R_g = 620\Omega$, $\text{BW} = 20\text{Hz} \sim 20\text{kHz}$, NAB EQ)
- No Input Coupling Capacitor
- Small Package : Shrink Pitch (1.78mm) Single In-line 12pin
- Operating Supply Voltage Range : $V_{CC(\text{opr.})} = 6 \sim 16\text{V}$

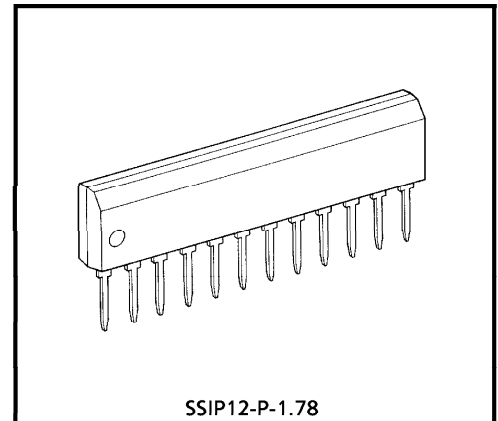

SSIP12-P-1.78
Weight : 0.65g (Typ.)

BLOCK DIAGRAM

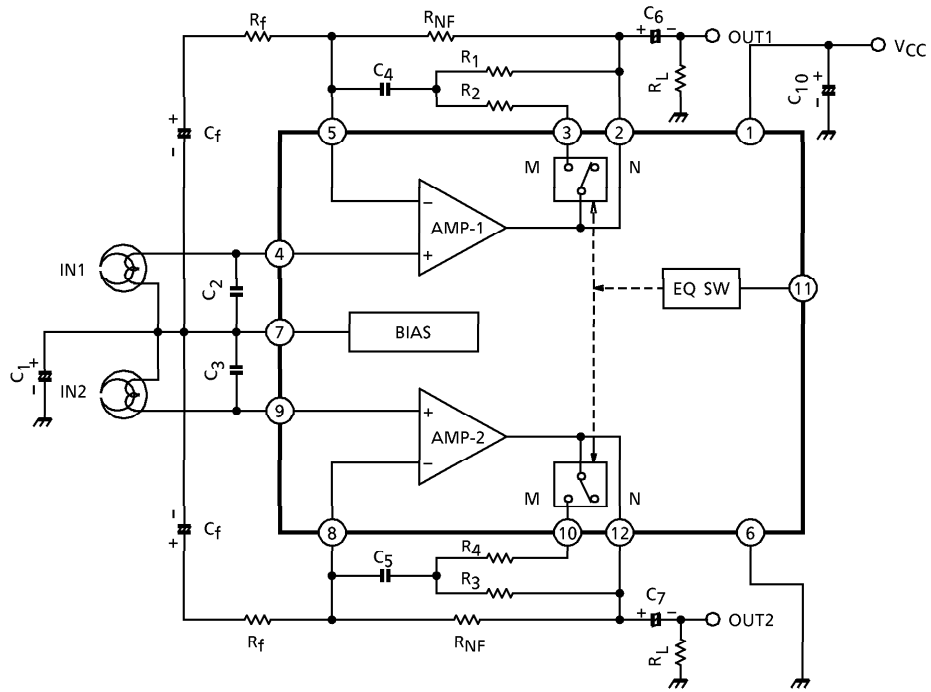

APPLICATION INFORMATION

(1) Equalizer control switch

Pin① is coupled to the base of Q₁ (PNP-Tr) as shown in Fig.1.

The emitter potential of Q₁ is 3.9Vdc.

Threshold voltage (pin①)

Metal	3.2~V _{CC}
Normal	0~2.4V

(2) C₂~3

Capacitor C₂/C₃ may be required for preventing a instability caused by the pattern layout or interference of external high frequency signal.

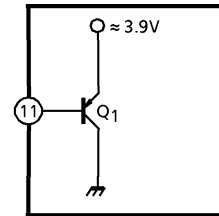

(Fig.1)

MAXIMUM RATINGS (Ta = 25°C)

CHARACTERISTIC	SYMBOL	RATING	UNIT
Supply Voltage	V _{CC}	16	V
Power Dissipation	P _D (Note)	750	mW
Operating Temperature	T _{opr}	- 30~75	°C
Storage Temperature	T _{stg}	- 55~150	°C

(Note) Derated above Ta = 25°C in the proportion of 6mW/°C.

TYP. DC VOLTAGE OF EACH TERMINAL
($V_{CC} = 9V$, $T_a = 25^\circ C$, Dual mode test circuit)

TERMINAL No.	1	2	3	4	5	6	7	8	9	10	11	12
DC-Voltage (V)	V_{CC}	3.0	3.0	3.0	3.0	GND	3.0	3.0	3.0	3.0	3.5	3.0

ELECTRICAL CHARACTERISTICS

(Unless otherwise specified, $V_{CC} = 9V$, $f = 1kHz$, $R_L = 10k\Omega$, $R_g = 600\Omega$, $T_a = 25^\circ C$, Normal EQ)

CHARACTERISTIC	SYMBOL	TEST CIRCUIT	TEST CONDITION	MIN.	TYP.	MAX.	UNIT
Quiescent Current	$I_{CCQ(1)}$	—	$V_{IN} = 0$, Normal EQ	—	5.0	—	mA
	$I_{CCQ(2)}$	—	$V_{IN} = 0$, Metal EQ	—	6.0	9.0	
Open Loop Voltage Gain	G_{VO}	—	$C_f = 100\mu F$, $R_f = 0$	—	98	—	dB
Maximum Output Voltage	V_{OM}	—	THD = 0.5%	1.5	2.0	—	V_{rms}
Total Harmonic Distortion	THD	—	$V_{OUT} = 0.5V_{rms}$	—	0.035	0.12	%
Equivalent Input Noise Voltage	V_{NI}	—	$R_g = 620\Omega$, NAB BW = 20Hz~20kHz	—	0.9	1.7	μV_{rms}
Input Resistance	R_{IN}	—	—	—	500	—	$k\Omega$
Ripple Rejection Ratio	R.R.	—	$f_{ripple} = 100Hz$, $V_{IN} = 1V_{rms}$	—	55	—	dB

TEST CIRCUIT

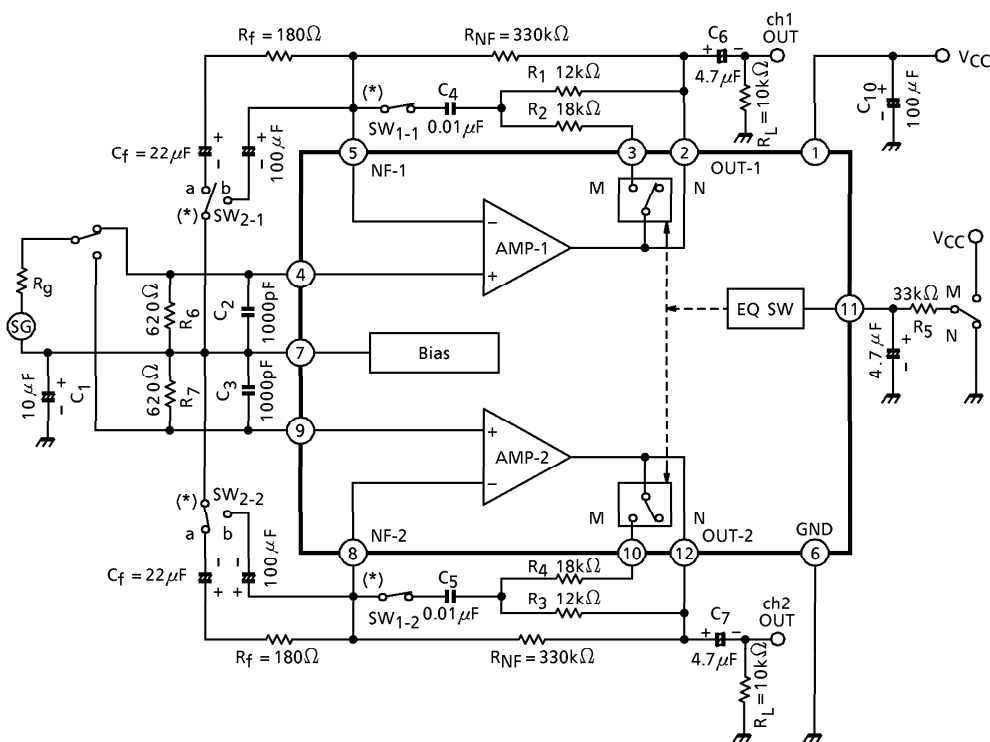

(*) G_{VO} Test : SW1-1, 2 = OFF, SW2-1, 2 = b

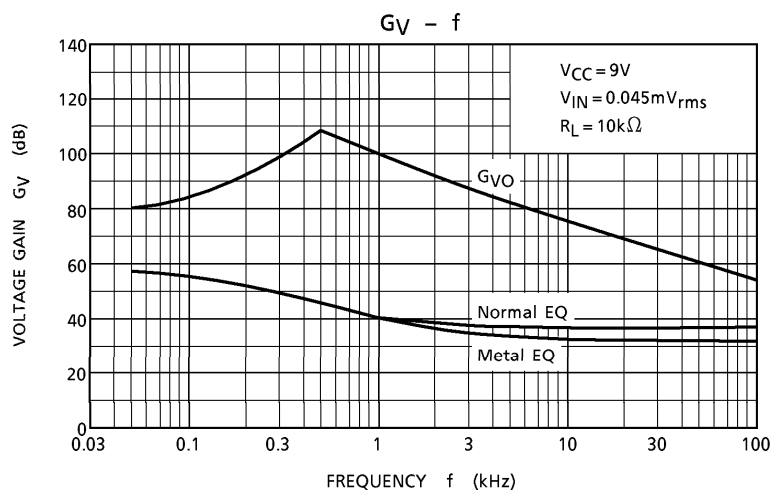
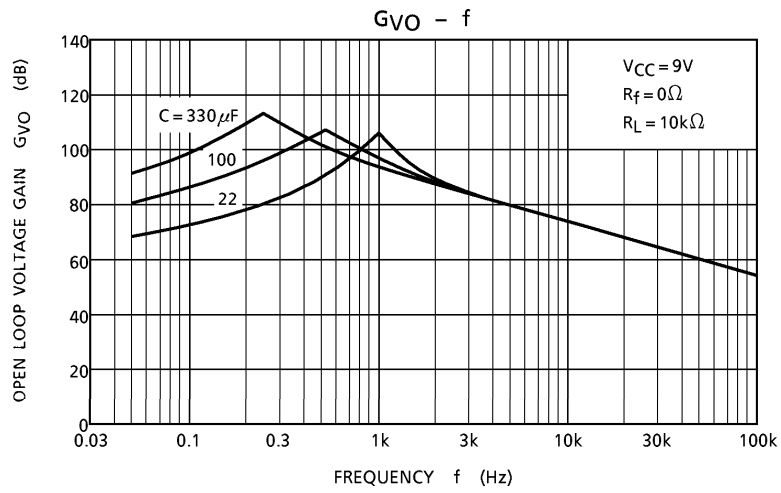
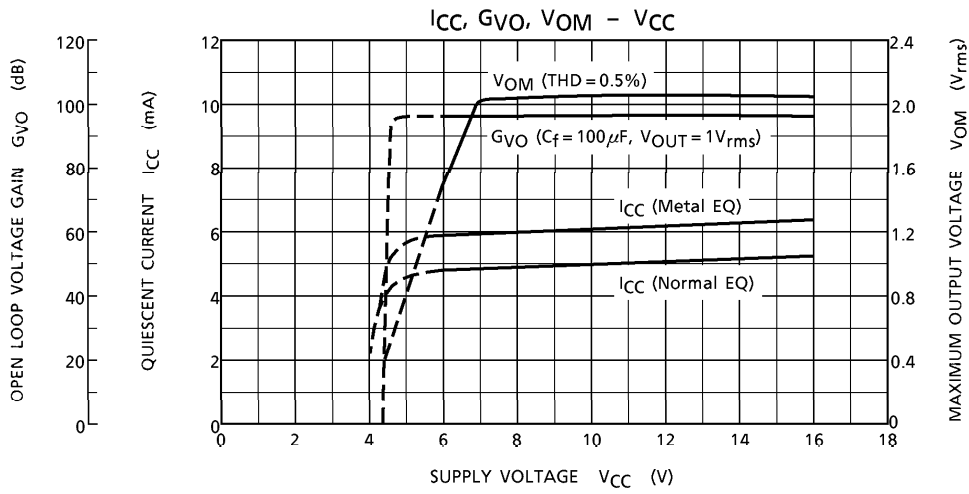

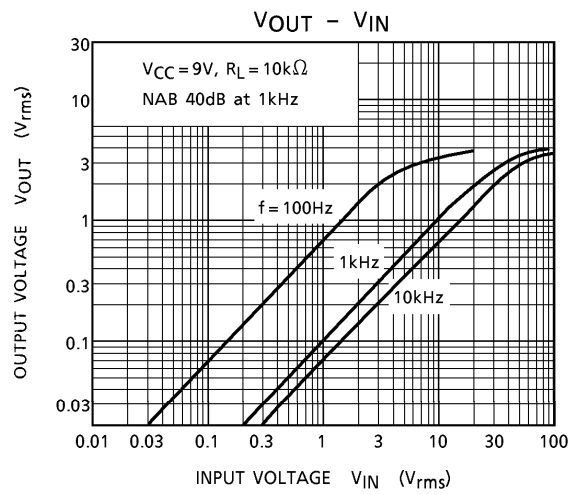
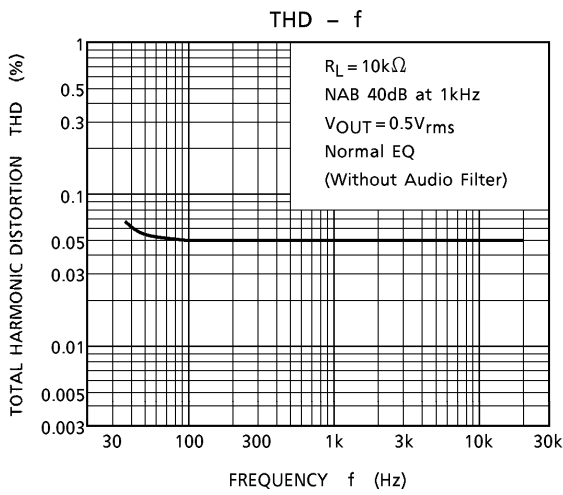
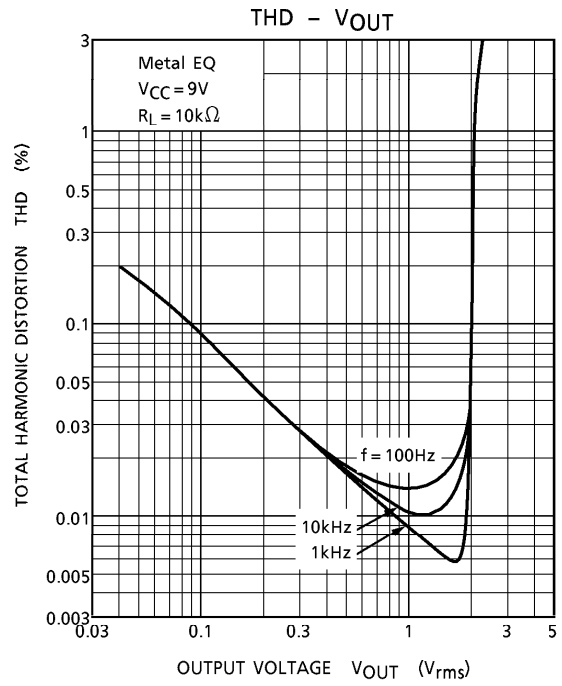
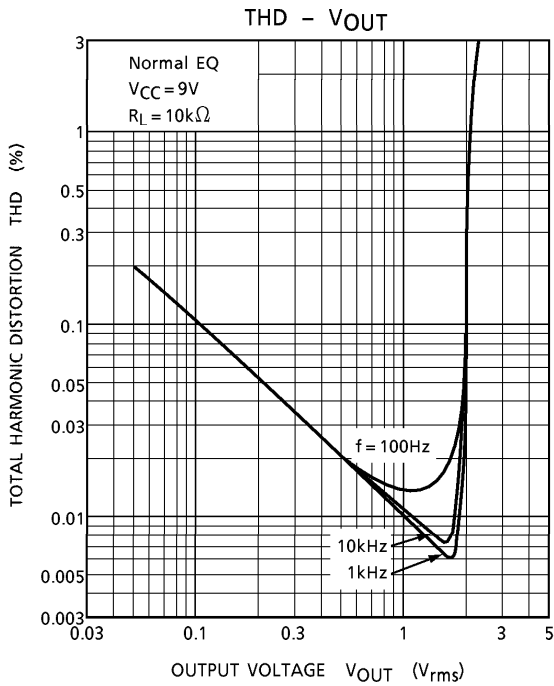

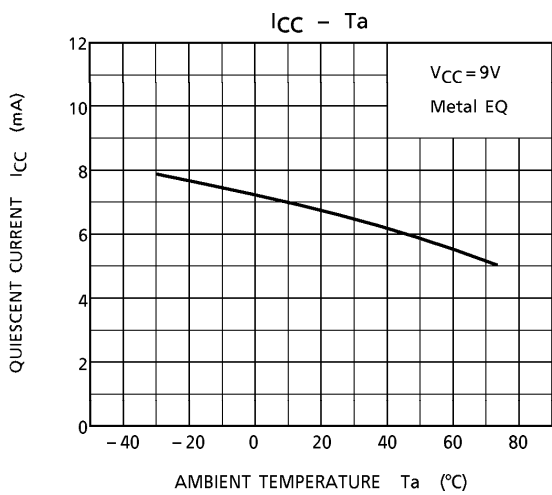
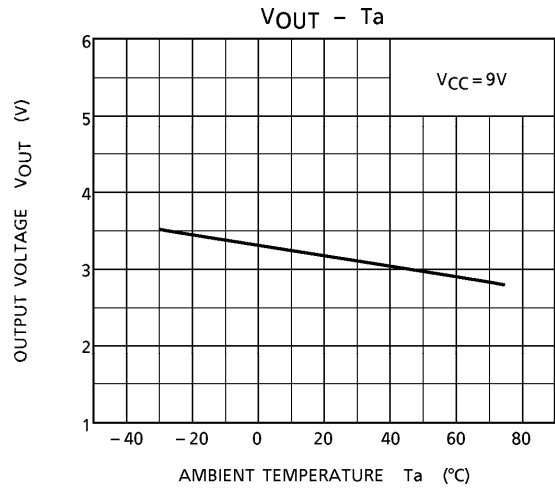
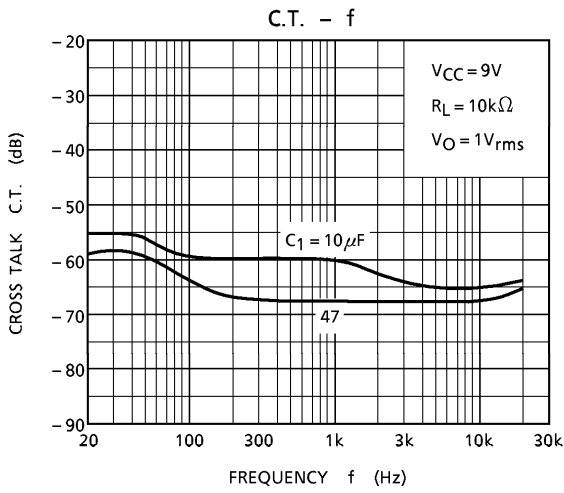
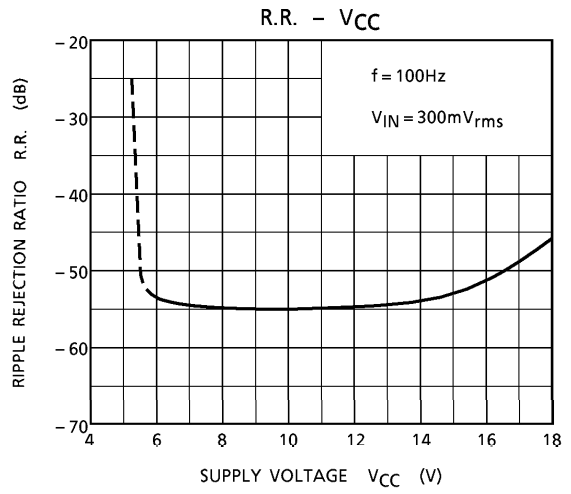
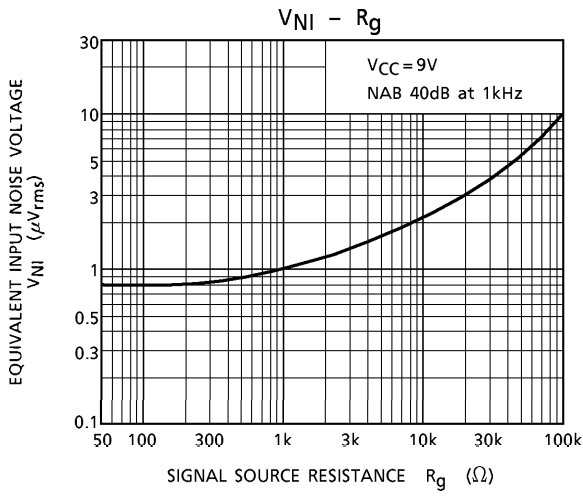

APPLICATION CIRCUIT

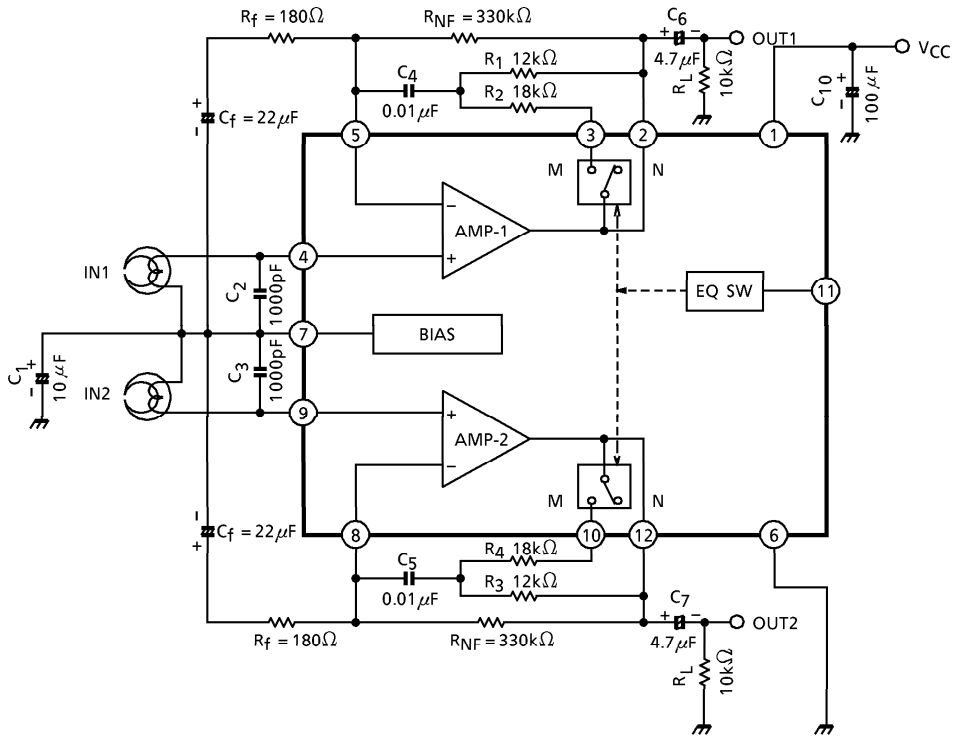

PACKAGE DIMENSIONS
SSIP12-P-1.78

Unit : mm

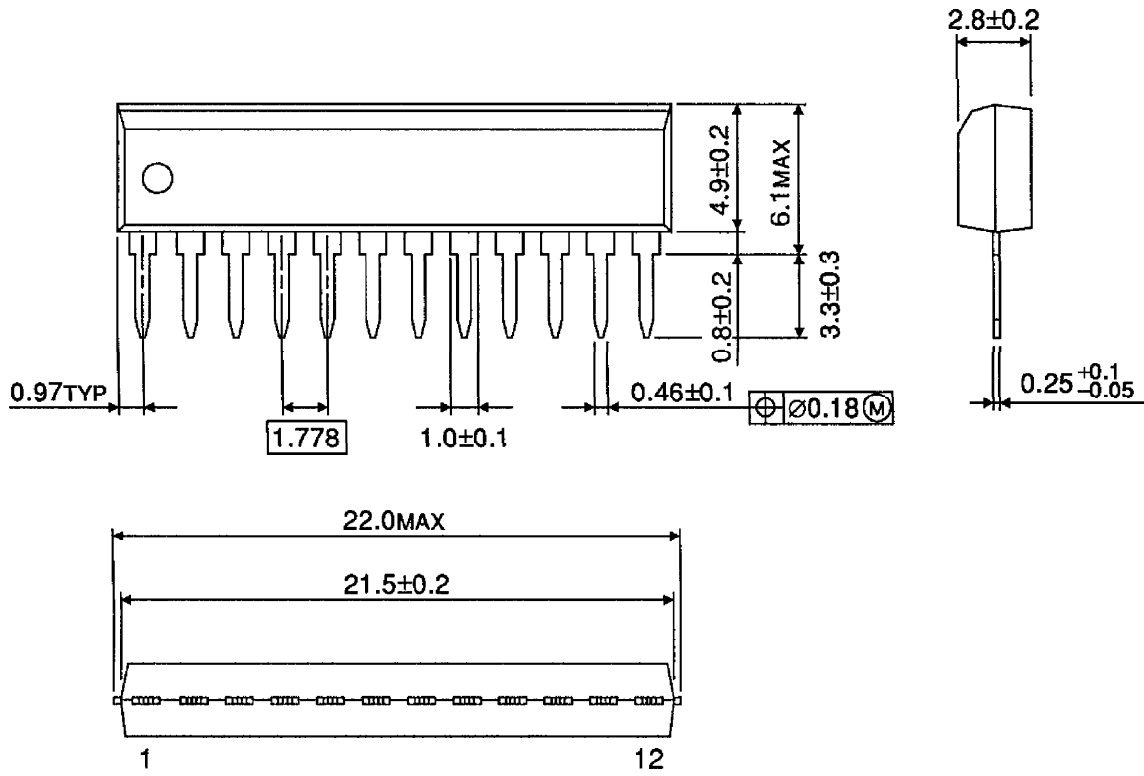

Weight : 0.65g (Typ.)

RESTRICTIONS ON PRODUCT USE

000707EBA

- TOSHIBA is continually working to improve the quality and reliability of its products. Nevertheless, semiconductor devices in general can malfunction or fail due to their inherent electrical sensitivity and vulnerability to physical stress. It is the responsibility of the buyer, when utilizing TOSHIBA products, to comply with the standards of safety in making a safe design for the entire system, and to avoid situations in which a malfunction or failure of such TOSHIBA products could cause loss of human life, bodily injury or damage to property. In developing your designs, please ensure that TOSHIBA products are used within specified operating ranges as set forth in the most recent TOSHIBA products specifications. Also, please keep in mind the precautions and conditions set forth in the "Handling Guide for Semiconductor Devices," or "TOSHIBA Semiconductor Reliability Handbook" etc..
- The TOSHIBA products listed in this document are intended for usage in general electronics applications (computer, personal equipment, office equipment, measuring equipment, industrial robotics, domestic appliances, etc.). These TOSHIBA products are neither intended nor warranted for usage in equipment that requires extraordinarily high quality and/or reliability or a malfunction or failure of which may cause loss of human life or bodily injury ("Unintended Usage"). Unintended Usage include atomic energy control instruments, airplane or spaceship instruments, transportation instruments, traffic signal instruments, combustion control instruments, medical instruments, all types of safety devices, etc.. Unintended Usage of TOSHIBA products listed in this document shall be made at the customer's own risk.
- The products described in this document are subject to the foreign exchange and foreign trade laws.
- The information contained herein is presented only as a guide for the applications of our products. No responsibility is assumed by TOSHIBA CORPORATION for any infringements of intellectual property or other rights of the third parties which may result from its use. No license is granted by implication or otherwise under any intellectual property or other rights of TOSHIBA CORPORATION or others.
- The information contained herein is subject to change without notice.