

TOSHIBA LED LAMP InGaAlP YELLOW LIGHT EMISSION

TLYH262

PANEL CIRCUIT INDICATOR

- 3.1mm DIAMETER (T1)
- InGaAlP YELLOW LED
- All Plastic Mold Type.
- Colorless Clear Lens
- Low Drive Current, High Intensity Yellow Light Emission
Recommended Forward Current : $I_F = 1 \sim 20\text{mA}$ (DC)
- All Plastic Molded Lens, Provides an Excellent ON-OFF Contrast Ratio.
- Fast Response Time, Capable of Pulse Operation.
- High Power Luminous Intensity
- APPLICATIONS : Suitable for Backlighting.

MAXIMUM RATINGS (Ta = 25°C)

CHARACTERISTIC	SYMBOL	RATING	UNIT
Forward Current (DC)	I_F	50	mA
Reverse Voltage	V_R	4	V
Power Dissipation	P_D	125	mW
Operating Temperature Range	T_{opr}	-30~85	°C
Storage Temperature Range	T_{stg}	-40~120	°C

Unit in mm

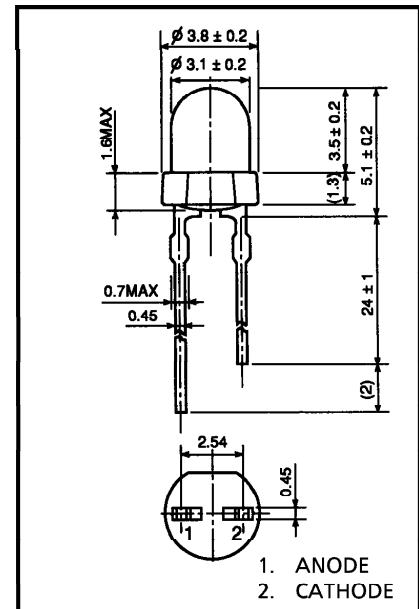

JEDEC	—
EIAJ	—
TOSHIBA	4-3H1

Weight : 0.14g

961001EAC2

- TOSHIBA is continually working to improve the quality and the reliability of its products. Nevertheless, semiconductor devices in general can malfunction or fail due to their inherent electrical sensitivity and vulnerability to physical stress. It is the responsibility of the buyer, when utilizing TOSHIBA products, to observe standards of safety, and to avoid situations in which a malfunction or failure of a TOSHIBA product could cause loss of human life, bodily injury or damage to property. In developing your designs, please ensure that TOSHIBA products are used within specified operating ranges as set forth in the most recent products specifications. Also, please keep in mind the precautions and conditions set forth in the TOSHIBA Semiconductor Reliability Handbook.
- Gallium arsenide (GaAs) is a substance used in the products described in this document. GaAs dust and fumes are toxic. Do not break, cut or pulverize the product, or use chemicals to dissolve them. When disposing of the products, follow the appropriate regulations. Do not dispose of the products with other industrial waste or with domestic garbage.
- The information contained herein is presented only as a guide for the applications of our products. No responsibility is assumed by TOSHIBA CORPORATION for any infringements of intellectual property or other rights of the third parties which may result from its use. No license is granted by implication or otherwise under any intellectual property or other rights of TOSHIBA CORPORATION or others.
- The information contained herein is subject to change without notice.

ELECTRO-OPTICAL CHARACTERISTICS (Ta = 25°C)

CHARACTERISTIC		SYMBOL	TEST CONDITION	MIN.	TYP.	MAX.	UNIT
Forward Voltage		V_F	$I_F = 20\text{mA}$	—	2.1	2.5	V
Reverse Current		I_R	$V_R = 4\text{V}$	—	—	50	μA
Luminous Intensity	TLYH262	I_V	$I_F = 20\text{mA}$ (Note)	85.0	300	—	mcd
	TLYH262 (PQ)			153	—	736	
Peak Emission Wavelength		λ_p	$I_F = 20\text{mA}$	—	590	—	nm
Spectral Line Half Width		$\Delta\lambda$	$I_F = 20\text{mA}$	—	13	—	nm
Dominant Wavelength		λ_d	$I_F = 20\text{mA}$	—	587	—	nm

(Note) Rank selection carried out under next range respectively, although it needs $\pm 15\%$ additional for guaranteed limits.

N : 100-200mcd, P : 180-360mcd, Q : 320-640mcd.

PRECAUTION

Please be careful of the followings

- Soldering temperature : 260°C MAX. Soldering time : 3s MAX.
(Soldering portion of lead : up to 2mm from the body of the device)
- If the lead is formed, the lead should be formed up to 5mm from the body of the device without forming stress to the resin. Soldering should be performed after lead forming.

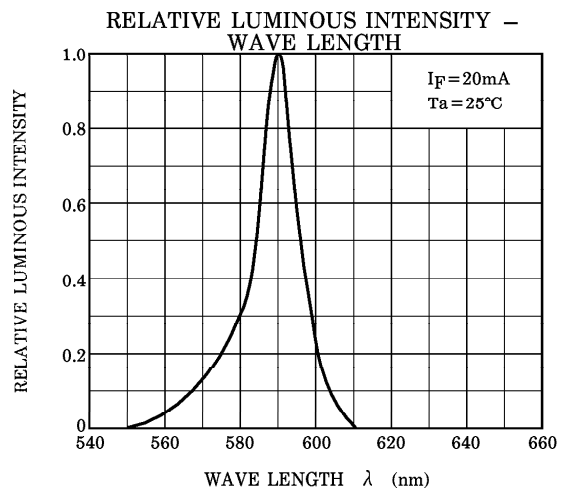
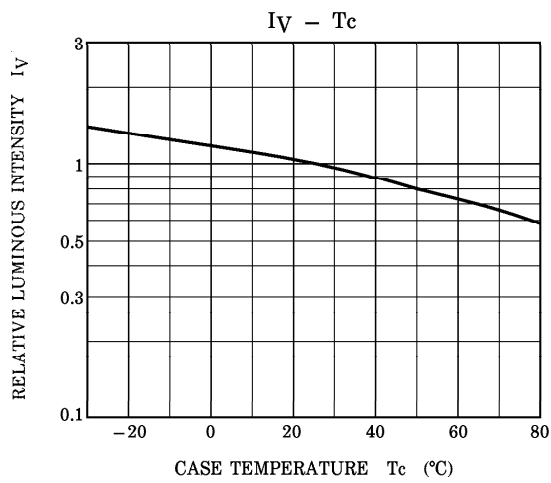
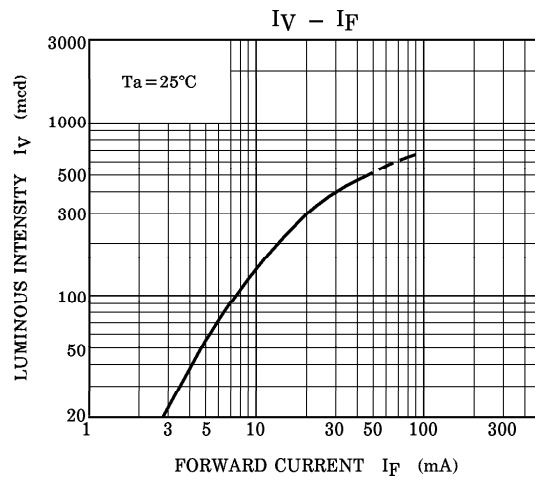
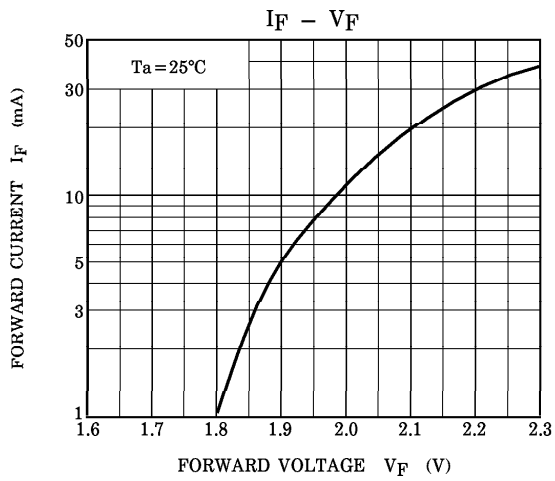

RADIATION PATTERN

