

## 14-BIT DIGITAL-TO-SYNCHRO CONVERTER HIGH EFFICIENCY: POWERED FROM REFERENCE INPUT

### FEATURES

#### DESCRIPTION

The DSC-544 digital-to-synchro (D/S) converter compliments DDC's low profile DSC-644 industry standard by providing additional features. The DSC-544 has a 0.82" high profile and standard pinouts. The need for +15 V and -15 V power supplies has been eliminated. The unit is powered from the reference input by an internal pulsating power supply, making it very efficient. The reduced heat dissipation has made it possible to increase the load at 400 Hz by a factor of three, and the power output at 60 Hz is limited only by the size of the internal power transformer.

The DSC-544 also retains the many improved features of the DSC-644. The output is fully protected against overloads, transients from load kick-backs, short circuits and overheating. An aluminum top plate in the module improves thermal dissipation. In addition, the circuit design provides a smoother, more accurate output with

improved transient response and negligible scale factor variation.

#### APPLICATIONS

The DSC-544 is the preferred D/S converter when its special features are required: elimination of external  $\pm 15$  V power supplies, elimination of an external transformer at 60 Hz, greater drive capability at 400 Hz, and less heat dissipation. The converter can be used in many applications where digitized shaft angle data must be converted to synchro form to drive control transformers, control differential transmitters, and angle indicators. Because these converters are very rugged, and meet the requirements of MIL-STD-202, they are suitable for the most severe industrial and military applications, including military ground support and avionics. They are very useful in computer-based systems where digital-to-synchro information is used, such as simulators, flight trainers, flight instrumentation, and fire control systems.

- **Power Dissipation Cut In Half:**
  - 4.5 VA at 400 Hz Dissipates 6 W
  - 1.5 VA at 60 Hz Dissipates 3 W
- **No External +15 V or -15 Supplies Required**
- **No External Transformer Required at 60 Hz**
- **Reliable:**
  - Rugged Power Amplifiers with Current Limiting
  - Short Circuit Protection
  - Overvoltage Transient Protection
  - Thermal Cutoff
- **Digital Input:**
  - CMOS and TTL Compatible
  - Parallel Binary Angle Input
- **Output:**
  - Transformer-Isolated
  - 90 V Synchro Output at 400 Hz and 60 Hz

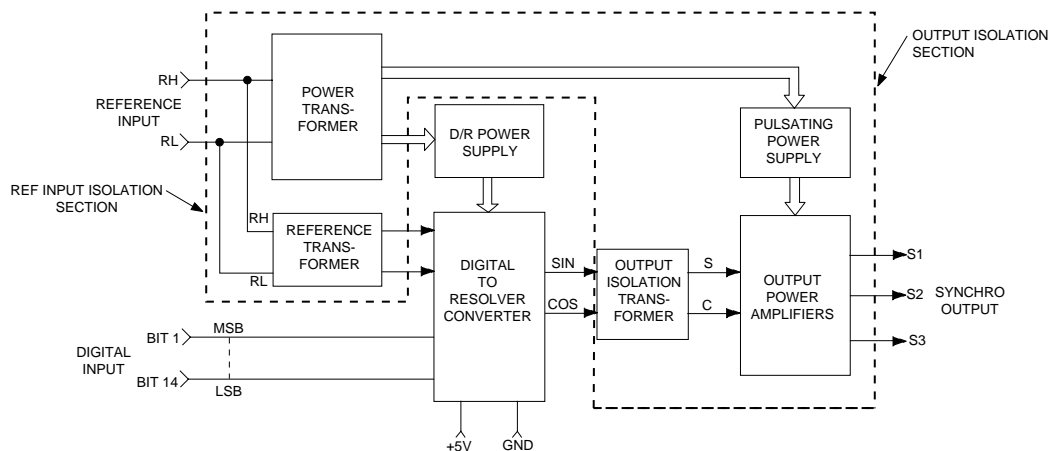

FIGURE 1. DSC-544 BLOCK DIAGRAM

TABLE 1. DSC-544 SPECIFICATIONS	
PARAMETER	VALUE
<b>RESOLUTION</b>	14 bits
<b>ACCURACY (TO FULL LOAD)</b> Output Accuracy Differential Linearity	±4 minutes ±1 LSB max
<b>ANALOG OUTPUT (TRANSFORMER-ISOLATED)</b> Drive Capability (L-L Balanced) Synchro Output 90V rms L-L, 360-440 Hz Option H 90V rms L-L, 57-63 Hz Option I Output Scale Factor Absolute (All Causes)  Variation With Digital Angle Output Quadrature	1.33 kΩ min  4.0 kΩ min  ±2% max simultaneous amplitude variation on all output lines, including variation with digital angle. Output amplitude tracks reference input amplitude. ±0.1% max ±0.2% max
<b>DIGITAL INPUT</b> Logic Type  Loading The output amplifiers will drive loads with any phase angle from -90° to +90°.	Natural binary angle. parallel positive logic TTL compatible Transient protected CMOS 33 kΩ pull-up to +5 V  0.13 Std TTL loads
<b>REFERENCE INPUT (TRANSFORMER-ISOLATED)</b> Reference Voltage Level Max Voltage Without Damage Current No Load Option H Option I Additional With Load	115V rms ±10% 138V rms  40 mA max 50 mA max 1 mA per mA of load
<b>POWER SUPPLY</b> Voltage Max Voltage Without Damage Current	+5 V±5% +7 V 20 mA max
<b>TEMPERATURE RANGES</b> Operating (Temperature Of Metal Plate On Top Of Case) -1 Option -3 Option Storage	-55°C to +85°C 0°C to +70°C -55°C to +125°C
<b>PHYSICAL CHARACTERISTICS</b> Size (Encapsulated Module)  Weight	3.125 x 2.625 x 0.82 inches (7.94 x 6.67 x 2.08 cm)  8 oz (227 gm)
<b>NOTE: These specifications apply over operating temperature and frequency range, ±5% power supply variation, ±10% reference amplitude variation, up to 10% harmonic distortion on reference input, and for any load up to full load.</b>	

## INTRODUCTION

The DSC-544 circuit is divided into three parts which are transformer-isolated from each other (see FIGURE 1). The first part contains the reference input, the second part contains the digital input and an internal digital-to-resolver (D/R) converter, and the third part contains output power amplifiers and an associated pulsating power supply.

Reference input isolation is provided by the reference transformer and by the power transformer. The converter output signals are proportional to the applied reference, and any distortion in the reference input will appear in the output signals. The power transformer has a voltage clamp which protects the power amplifiers against transients in the reference input.

The internal D/R converter in the DSC-544 operates from an internal power supply connected to the reference input. The circuit in the internal D/R is based on an algorithm whose theoretical math error is only ±3.5 arc-seconds (less than 5% of 1 LSB) and whose theoretical scale factor variation with angle is less than ±0.015%. The output is clean, with negligible glitches at major transition points. The accuracy and scale factor errors are not limited by the physical components, but by the algorithm.

The digital inputs are transient-protected CMOS switches with 33 kΩ pull-up resistors that are connected to the +5 V supply, and can be driven by all standard TTL gates. If the TTL gates drive other loads as well, the circuit must allow the 33 kΩ resistors to pull-up the logic 1 level to within 1.0 V of the +5 V supply. Bit weights for the 14 binary inputs are given in TABLE 2. The angle is determined by adding bits that are in the logic 1 state.

TABLE 2. BIT WEIGHT TABLE		
BIT	DEG/BIT	MIN/BIT
1 MSB	180	10,800
2	90	5,400
3	45	2,700
4	22.5	1,350
5	11.25	675
6	5.625	337.5
7	2.813	168.75
8	1.406	84.38
9	0.7031	42.19
10	0.3516	21.09
11	0.1758	10.55
12	0.0879	5.27
13	0.0439	2.64
14 LSB	0.0220	1.32

The output section of the DSC-544 offers the most benefits to its users. The pulsating power supply produces two unfiltered, full-wave-rectified positive and negative voltages (see FIGURE 2). These voltages are in phase with the amplifier output voltage because power is derived from the reference input. The amplitude of the two voltages only needs to be a few volts greater than the power amplifier voltage, since both will change together if the reference voltage level changes. As FIGURE 2 indicates, the

positive and negative pulsating power supply voltage levels will consistently be lower than the constant DC levels of the DC supply. Since the voltage levels are lower, the power consumed will be much less. The power dissipated as heat is equal to the amplifier current times the difference in voltage between the power supply and the output. For the DSC-544, the power dissipated is reduced by approximately 50% for reactive loads.

Another advantage of deriving power from the reference input is that the amplifier section power is easily transformer-isolated from the D/R converter. The converter output isolation transformer can therefore be located in front of the power amplifiers. Since it does not transfer power, it can be made smaller and an internal transformer can be used for 60 Hz.

Minimum load impedances are listed in TABLE 1, under Drive Capability. The DSC-544 is capable of driving the specified load impedances under worst case conditions. The minimum load impedances correspond to 4.5 VA at 400 Hz and 1.5 VA at 60 Hz when frequencies and voltage levels are at their nominal values.

Adequate air circulation is required over the metal top of the converter module. A thermal cutout will disable the converter's output amplifiers if its internal temperature reaches 125°C. The output is automatically restored when the temperature drops below 125°C.

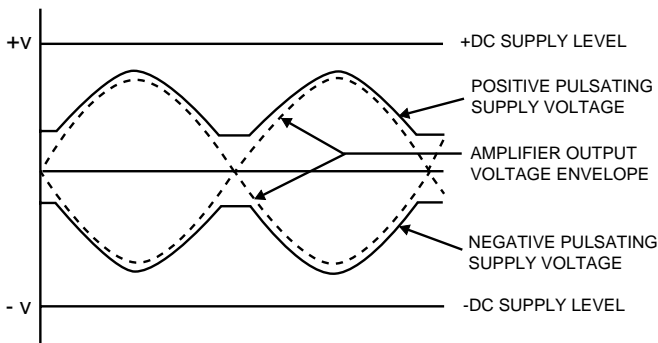

**FIGURE 2. PULSATING POWER SUPPLY VOLTAGE WAVEFORMS**

### OUTPUT PHASING AND SCALE FACTOR

The analog output signals have the following phase relationship and are shown in FIGURE 3.

$$\begin{aligned} S1-S3 &= (RH-RL) A_o [1 + A(\theta) \sin \theta] \\ S3-S2 &= (RH-RL) A_o [1 + A(\theta) \sin (\theta + 120^\circ)] \\ S2-S1 &= (RH-RL) A_o [1 + A(\theta) \sin (\theta + 240^\circ)] \end{aligned}$$

The output amplitudes simultaneously track the reference voltage fluctuations because they are proportional to (RH-RL). The amplitude factor  $A_o$  is 90/115 for 90V rms L-L output. The maximum variation in  $A_o$  from all causes is  $\pm 1.9\%$ . The term  $A(\theta)$  represents the variation of the amplitude with the digi-

tal input angle.  $A(\theta)$ , which is called the scale factor variation, is a smooth function of  $\theta$  without discontinuities and is less than  $\pm 0.001$  for all values of  $\theta$ . The total maximum variation of  $A_o (1 + A(\theta))$  is therefore  $\pm 2\%$ . Because  $A(\theta)$  is so small, the DSC-544 can be used to drive systems such as X-Y plotters or CRT displays in which the sine and cosine outputs are used independently (not ratiometrically as in a control transformer).

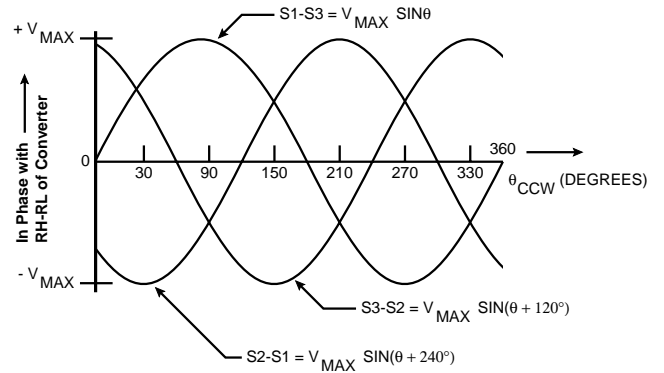

**FIGURE 3. SYNCHRO OUTPUT SIGNALS**

### DRIVING CT AND CDX LOADS

When driving CT and CDX loads the DSC-544 must have enough steady-state power capability to drive the  $Z_{so}$  of the load.  $Z_{so}$  (stator impedance with rotor open-circuited) is measured as shown in FIGURE 4.

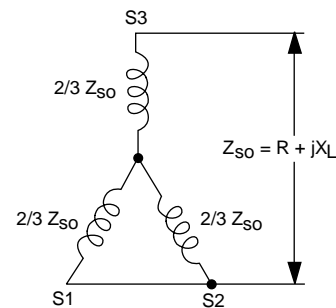

**FIGURE 4.  $Z_{SO}$  MEASUREMENT**

TABLE 3 lists the load impedance of some typical control transformers. Control transformers are highly inductive loads and it is possible to save power by tuning inductive loads. Three capacitors may be placed across the legs of the synchro stator in a delta configuration as shown in FIGURE 5.

TABLE 3. TYPICAL CONTROL TRANSFORMERS AND THEIR LOAD IMPEDANCES		
MILITARY PART NUMBER	SIZE	Z <sub>SO</sub>
26V 08CT4c	08	100 + j490
26V 11CT4d	11	21 + j132
11CT4e	11	838 + j4955
15CT4c	15	1600 + j9300
15CT6b	15	1170 + j6780
18CT4c	18	1420 + j13260
18CT6b	18	1680 + j5040
23CT4a	23	1460 + j11050
23CT6a	23	1250 + j3980

The correct value of the capacitance C in Farads is given by:

$$C = \frac{X_L}{4\pi f R^2 + X_L^2}$$

where f is the carrier frequency and R and X<sub>L</sub> are the series real and reactive components of Z<sub>SO</sub>. High grade capacitors must be used and they must be able to withstand the full AC output voltage.

When the load has been tuned more loads can be driven in parallel, the load impedance Z is increased to :

$$Z = \frac{R^2 + X_L^2}{R}$$

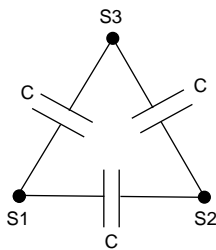

FIGURE 5. DELTA TUNING CONFIGURATION

## ACCURACY TESTS

The accuracy of the DSC-544 may be tested with a high accuracy synchro/resolver angle indicator and a load such as a control transformer (see FIGURE 6). The bits switched are set to the desired angle and the output angle is measured under load. The accuracy should conform to the specifications.

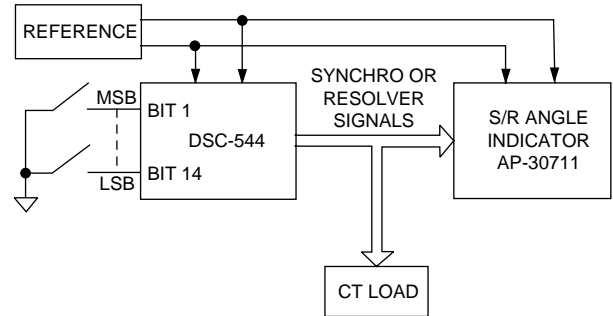

FIGURE 6. ACCURACY TEST CIRCUIT

## TEST METHODS

The DSC-544 converter modules are high-quality products whose semiconductor components are hermetically sealed. These modules will meet the specific test methods and conditions of MIL-STD-202E (see TABLE 4) unless alternative methods are specified by the customer in his procurement documentation.

TABLE 4. MIL-STD-202E TEST METHODS		
METHOD	CONDITION	COMMENT
204C	C	10G, 2000 Hz vibration
213B	A	50G, 11 ms shock
106D*	--	Moisture
107D	A	Thermal shock
101D	B	Salt spray
105C	B	50,000 ft, altitude
* when conformally coated on P.C. board		

Dimensions in inches (mm).

*Drawing not to scale.*

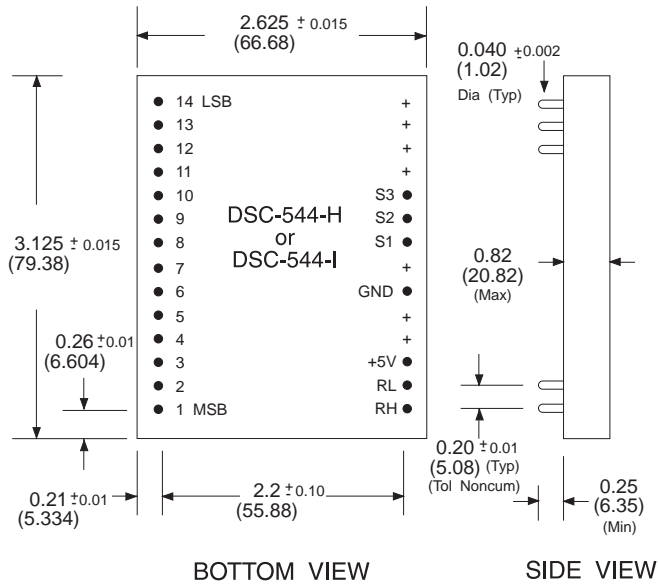

**Notes:**

1. Pin labels on bottom view are for reference only.
2. All dimensions shown are in inches (mm).
3. Pin material meets solderability requirements of MIL-STD-202, Method 208C.
4. Case material is glass filled Diallyl Phthalate per MIL-M-14, Type SDG-F, except top surface is black anodized aluminum plate for heat transfer.
5. Any LSB pins not used should be grounded.

**FIGURE 7. DSC-544 MECHANICAL OUTLINE**

**ORDERING INFORMATION**

DSC-544-X-X-R

**R = Enhanced Reliability**

**Operating Temperature Range of Case (Metal Top):**

1 = 55° to +85°C

3 = 0° to +70°C

**Synchro Output Voltage Level and Frequency:**

H = 90 V L-L, 360 - 440 Hz

I = 90 V L-L, 57 - 63 Hz

**Note:** If a socket is required, order part number 9010.

The information in this data sheet is believed to be accurate; however, no responsibility is assumed by Data Device Corporation for its use, and no license or rights are granted by implication or otherwise in connection therewith.  
Specifications are subject to change without notice.



105 Wilbur Place, Bohemia, New York 11716-2482

**For Technical Support - 1-800-DDC-5757 ext. 7389 or 7413**

**Headquarters** - Tel: (631) 567-5600 ext. 7389 or 7413, Fax: (631) 567-7358

**Southeast** - Tel: (703) 450-7900, Fax: (703) 450-6610

**West Coast** - Tel: (714) 895-9777, Fax: (714) 895-4988

**Europe** - Tel: +44-(0)1635-811140, Fax: +44-(0)1635-32264

**Asia/Pacific** - Tel: +81-(0)3-3814-7688, Fax: +81-(0)3-3814-7689

**World Wide Web** - <http://www.ddc-web.com>



ILC DATA DEVICE CORPORATION  
REGISTERED TO ISO 9001  
FILE NO. A5976