

Low Dropout Voltage Regulator with Reset

■ GENERAL DISCRIPTION

The NJM2800 is a low dropout voltage regulator with reset function.

It provides up to 150mA of logic supply, and the reset function monitors either input or output voltage of the regulator with 2% accuracy.

It is suitable for local power supply and reset for small micro controller and other logic chips.

■ FEATURES

- Output Voltage Accuracy $V_o = \pm 2.2\%$
- Reset Voltage Accuracy $V_{reset} = \pm 2.0\%$
- Reset Hold Time $t_d = 10\text{ms} \pm 2.5\text{ms}$
- Quiescent Current $I_Q = 300\mu\text{A (max.)}$
- Open Collector Output
- Bipolar Technology
- Input Voltage Monitor type
- Package Outline SOT89 (5Pin) / MTP5
- Protection Circuit
 - 1. Current limit circuit
 - 2. Thermal overload protection circuit

■ OUTPUT VOLTAGE/RESET VALIDATED VOLTAGE

PART NO	Output Voltage	Reset Validated Voltage
NJM2800-2528	2.5V	2.8V
NJM2800-3342	3.3V	4.2V

■ BLOCK DIAGLAM

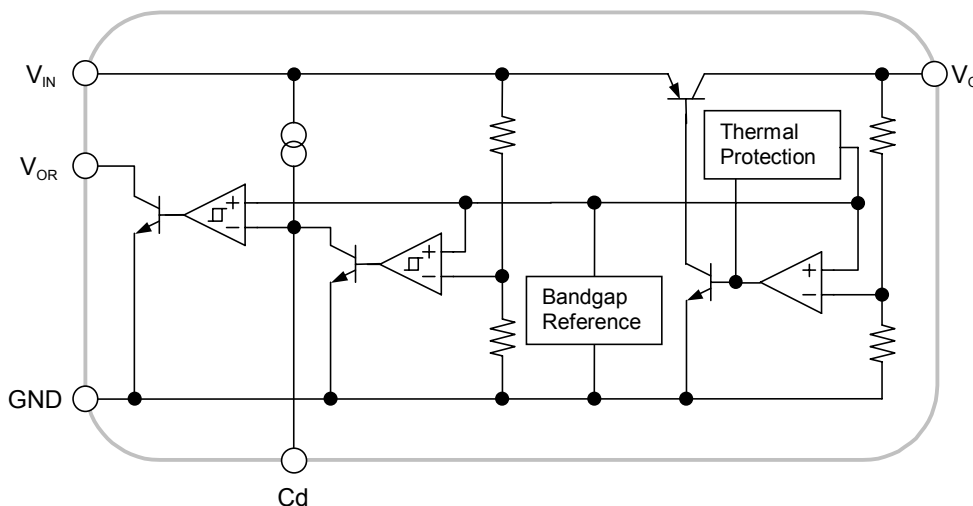

■ PACKAGE OUTLINE

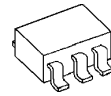

NJM2800F**



NJM2800U**

■ PIN CONFIGURATION

(MTP-5)

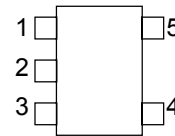

1. V_{IN}
2. GND
3. V_{OR}
4. C_d
5. V_{OUT}

(SOT-89)

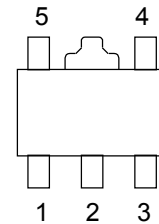

1. V_{OUT}
2. GND
3. C_d
4. V_{OR}
5. V_{IN}

■ ABSOLUTE MAXIMUM RATINGS

(Ta=25°C)

PARAMETER	SYMBOL	RATINGS	UNIT
Input Voltage	V _{IN}	+14	V
Power Dissipation	P _D	200 (MTP5)	mW
		350 (SOT-89)	
Operating Temperature	Topr	-40~+85	°C
Storage Temperature	Tstg	-40~+125	°C

■ ELECTRICAL CHARACTERISTICS (V_{IN}=V_O+1V, C_{IN}=0.1μF, C_O=1μF (V_O≤2.6V: C_O=2.2μF) Ta=25°C)

PARAMETER	SYMBOL	CONDITION	MIN.	TYP.	MAX.	UNIT
Quiescent Current	I _Q	I _O =0mA	-	250	350	μA
Regulator Block						
Output Voltage	V _O	I _O =30mA	-2.2%	-	+2.2%	V
Output Current	I _O	V _O -0.3V	150	200	-	mA
Line Regulation	ΔV _O /ΔV _{IN}	V _{IN} =V _O +1V~V _O +6V, I _O =30mA	-	-	0.10	%/V
Load Regulation	ΔV _O /ΔI _O	I _O =0~100mA	-	-	0.03	%/mA
Dropout Voltage	ΔV _{I_O}	I _O =60mA	-	0.10	0.18	V
Ripple Rejection	RR	E _{in} =200mV _{rms} , f=1kHz, I _O =10mA, V _O =3V	-	60	-	dB
Output Voltage Temperature Coefficient	ΔV _O /ΔT	Ta=0~85°C, I _O =10mA	-	±50	-	ppm/°C
Output Noise Voltage	V _{NO}	f=10Hz~100kHz, I _O =10mA, V _O =3V	-	45	-	μV _{rms}
Reset Block						
Voltage Detection	V _{RT}	V _{IN} =H→L	-2%	-	+2%	V
Hysteresis Voltage	V _{RTH}	V _{IN} =H→L→H	V _{RT} ×3	V _{RT} ×5	V _{RT} ×8	mV
Low Level Output	R _{ORL}	V _{IN} =V _{RT} -0.5V, R _L =100kΩ	-	100	300	mV
Output Leak Current	I _{ORH}	V _{IN} =V _{RT} -0.5V	-	-	0.1	μA
On time Output Current	I _{ORL}	V _{IN} =V _{RT} -0.5V, R _L =0Ω	5	-	-	mA
Reset Output Delay	t _d	V _{IN} =(V _{RT} -0.5V)→(V _{RT} +0.5V), C _d =0.1μF	9	10	11	mS
Operation Voltage Limit	V _{OPL}	V _{ORL} =0.4V	-	0.9	-	V

The above specification is a common specification for all output voltages.

Therefore, it may be different from individual specification for a specific output voltage.

■ TIMING CHART

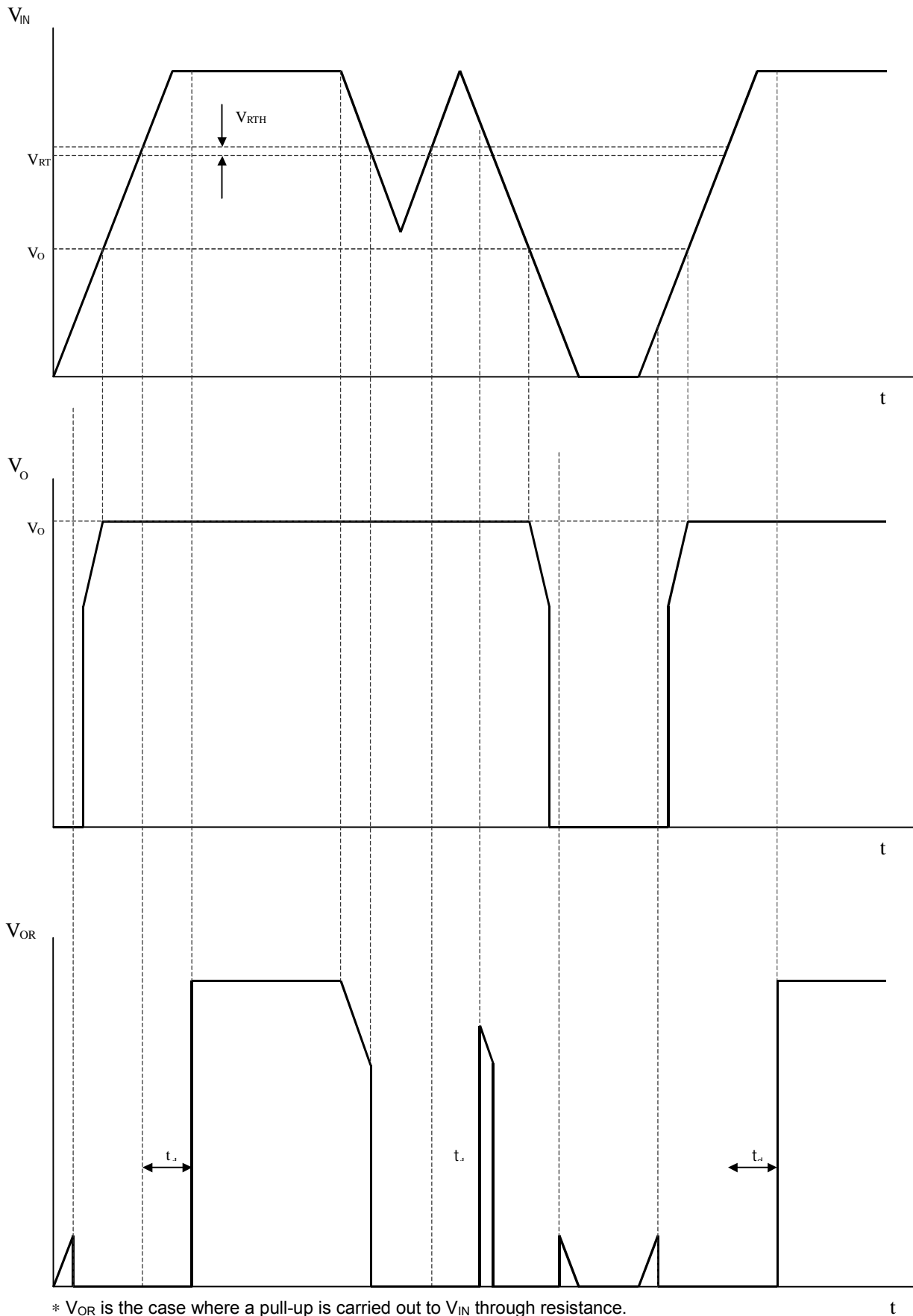

* V_{OR} is the case where a pull-up is carried out to V_{IN} through resistance.

■ TEST CIRCUIT

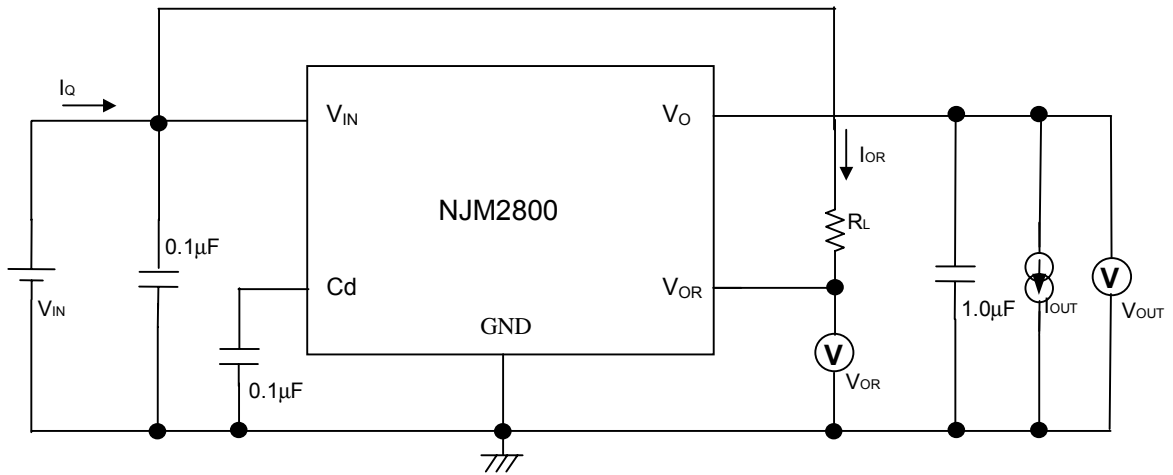

■ TYPICAL APPLICATIONS

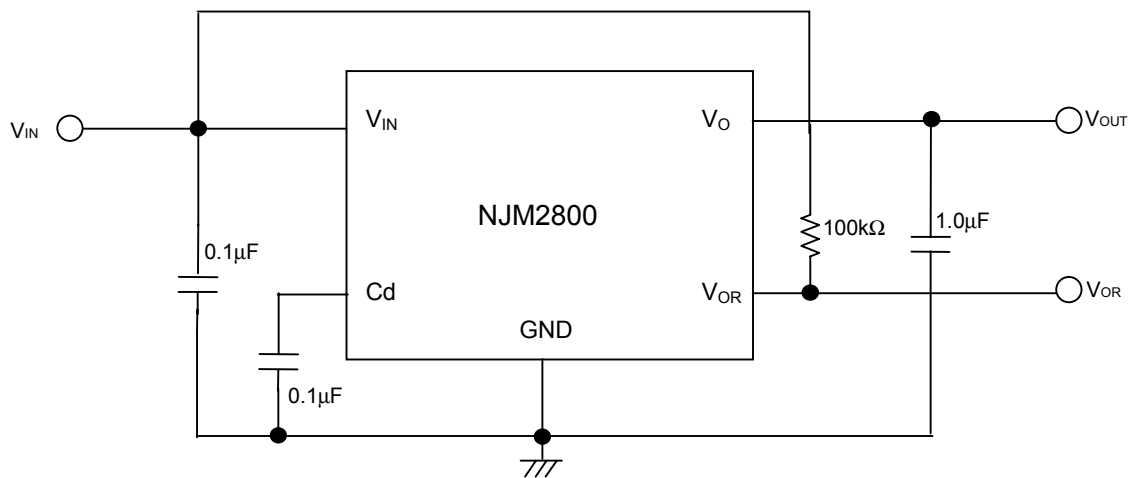

The specifications on this data book are only given for information, without any guarantee as regards either mistakes or omissions. The application circuit in this data book are described only to show representative usages of the product and not intended for the guarantee or permission of any right including the industrial rights.