

L1503SGx SUPER BRIGHT GREEN

L1503SRx SUPER BRIGHT RED

Features

- ULTRA BRIGHTNESS.
- BOTH DIFFUSED AND WATER CLEAR LENS ARE AVAILABLE.
- OUTSTANDING MATERIAL EFFICIENCY.
- RELIABLE AND RUGGED.
- IC COMPATIBLE/LOW CURRENT CAPABILITY.

Description

The Super Bright Green source color devices are made with Gallium Phosphide Green Light Emitting Diode.

The Super Bright Red source color devices are made with Gallium Aluminum Arsenide Red Light Emitting Diode.

Package Dimensions

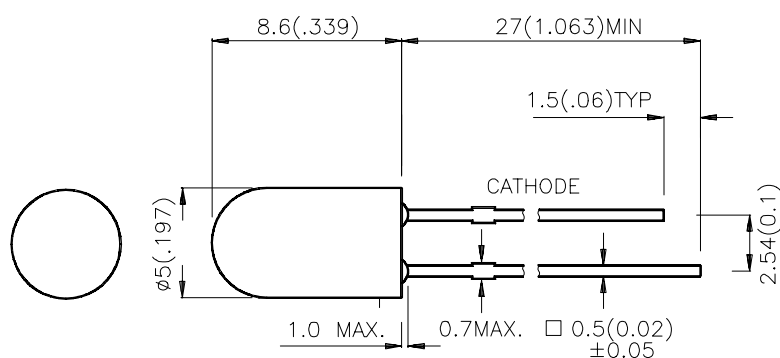

Notes:

1. All dimensions are in millimeters (inches).
2. Tolerance is $\pm 0.25 (0.01)$ unless otherwise noted.
3. Lead spacing is measured where the lead emerge package.
4. Specifications are subject to change without notice.

Selection Guide

Part No.	Dice	Lens Type	Iv (mcd) @ 20 mA		Viewing Angle
			Min.	Typ.	2θ1/2
L1503SGC	SUPER BRIGHT GREEN (GaP)	WATER CLEAR	70	200	30°
L1503SGT		GREEN TRANSPARENT	70	150	30°
L1503SRC/D	SUPER BRIGHT RED (GaAlAs)	WATER CLEAR	1000	1500	30°
L1503SRC/E			2000	2800	30°
L1503SRC/F			3500	4000	30°
L1503SRD		RED DIFFUSED	100	400	60°

Note:

1. θ1/2 is the angle from optical centerline where the luminous intensity is 1/2 the optical centerline value.

Electrical / Optical Characteristics at T_A=25°C

Symbol	Parameter	Device	Typ.	Max.	Units	Test Conditions
λ _{peak}	Peak Wavelength	Super Bright Red Super Bright Green	660 565		nm	IF=20mA
λ _D	Dominate Wavelength	Super Bright Red Super Bright Green	640 568		nm	IF=20mA
Δλ _{1/2}	Spectral Line Halfwidth	Super Bright Red Super Bright Green	20 30		nm	IF=20mA
C	Capacitance	Super Bright Red Super Bright Green	45 15		pF	VF=0V;f=1MHz
V _F	Forward Voltage	Super Bright Red Super Bright Green	1.85 2.2	2.5 2.5	V	IF=20mA
I _R	Reverse Current	All		10	μA	VR = 5V

Absolute Maximum Ratings at T_A=25°C

Parameter	Super Bright Red	Super Bright Green	Units
Power dissipation	100	105	mW
DC Forward Current	30	25	mA
Peak Forward Current [1]	155	140	mA
Reverse Voltage	5	5	V
Operating/Storage Temperature	-40°C To +85°C		
Lead Solder Temperature [2]	260°C For 5 Seconds		

Notes:

1. 1/10 Duty Cycle, 0.1ms Pulse Width.
2. 4mm below package base.

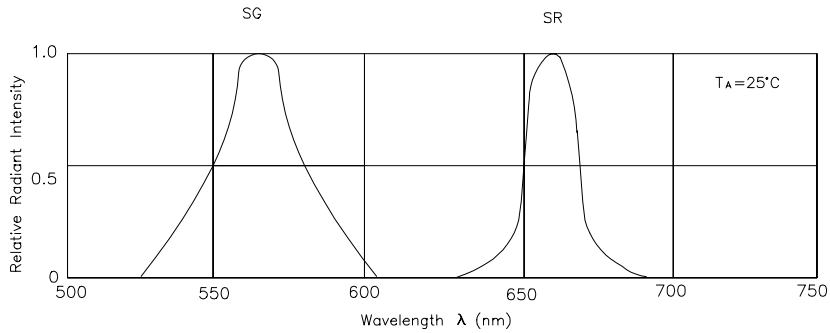

RELATIVE INTENSITY Vs. WAVELENGTH

Super Bright Green L1503SGC,L1503SGT

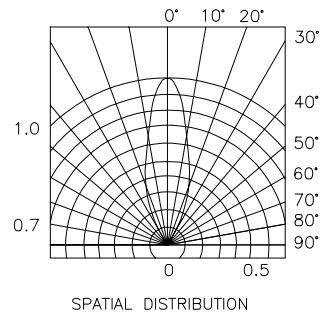
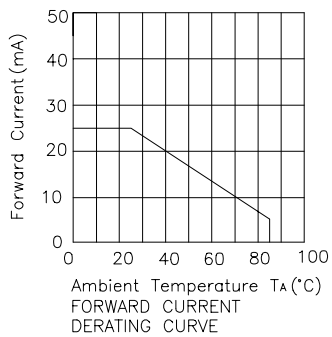
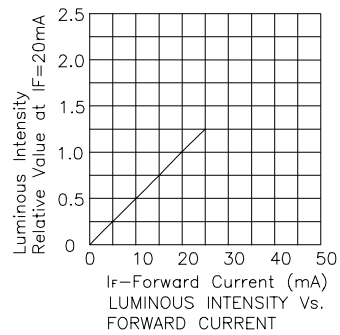
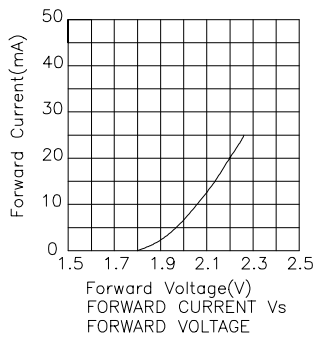

Super Bright Red L1503SRC/x,L1503SRD

