HB288064MM1

MultiMediaCard™
64 MByte

HITACHI

ADE-203-1191 (Z)
Preliminary
Rev. 0.0
Jul. 25, 2000

Description

The Hitachi MultiMediaCard™ HB288064MM1 is a highly integrated flash memory with serial and random access capability. It is accessible via a dedicated serial interface optimized for fast and reliable data transmission. This interface allows several cards to be stacked by through connecting their peripheral contacts. The HB288064MM1 is fully compatible to a new consumer standard, called the MultiMediaCard system standard defined in the MultiMediaCard system specification [1]. The MultiMediaCard system is a new mass-storage system based on innovations in semiconductor technology. It has been developed to provide an inexpensive, mechanically robust storage medium in card form for multimedia consumer applications. MultiMediaCard allows the design of inexpensive players and drives without moving parts. A low power consumption and a wide supply voltage range favors mobile, battery-powered applications such as audio players, organizers, palmtops, electronic books, encyclopedia and dictionaries. Using very effective data compression schemes such as MPEG, the MultiMediaCard will deliver enough capacity for all kinds of multimedia data: software/programs, text, music, speech, images, video etc.

Note: MultiMediaCard™ is a trademark of Siemens AG.

Features

- 64 MByte memory capacity
- On card error correction

Preliminary: The specifications of this device are subject to change without notice. Please contact your nearest Hitachi's Sales Dept. regarding specifications.



HB288064MM1

- MultiMediaCard system standard compatibility
 - System specification version 2.11 compliant
 - SPI interface supported
 - Block and partial block read supported (Command classes 0 and 2)
 - Stream read supported (Command class 1)
 - Block write and erase supported (Command classes 4 and 5)
 - Group write protection (Command classes 6)
 - Stream write supported (Command classes 3)
 - Password data access protection
 - Small erase block size of 512 bytes, tagged erase supported
 - Read block size programmable between 1 and 2048 bytes
 - $V_{CC} = 2.7\text{ V}$ to 3.6 V operation voltage range ($V_{CC} = 2.0\text{ V}$ to 3.6 V for the interface)
 - No external programming voltage required
 - Damage free powered card insertion and removal
 - 4kV ESD protection
- High speed serial interface with random access
 - Read speed: sustained: 13.7 Mbits/s (multi-block read)
 burst (one block): 20 Mbit/s
 - Write speed: sustained: 2.8 Mbit/s (multi-block write to pre-erased sectors)
 burst (one block): 20 Mbit/s
 - Up to 10 stacked card (at 20 MHz, $V_{CC} = 2.7$ to 3.6V)
 - Access time: 300 μs (max) (at 20 MHz, $V_{CC} = 2.7$ to 3.6V , random byte access (Typical case))
- Low power dissipation
 - High speed: 95 mW (max) (at 20 MHz, $V_{CC} = 2.7\text{ V}$)

Block Diagram

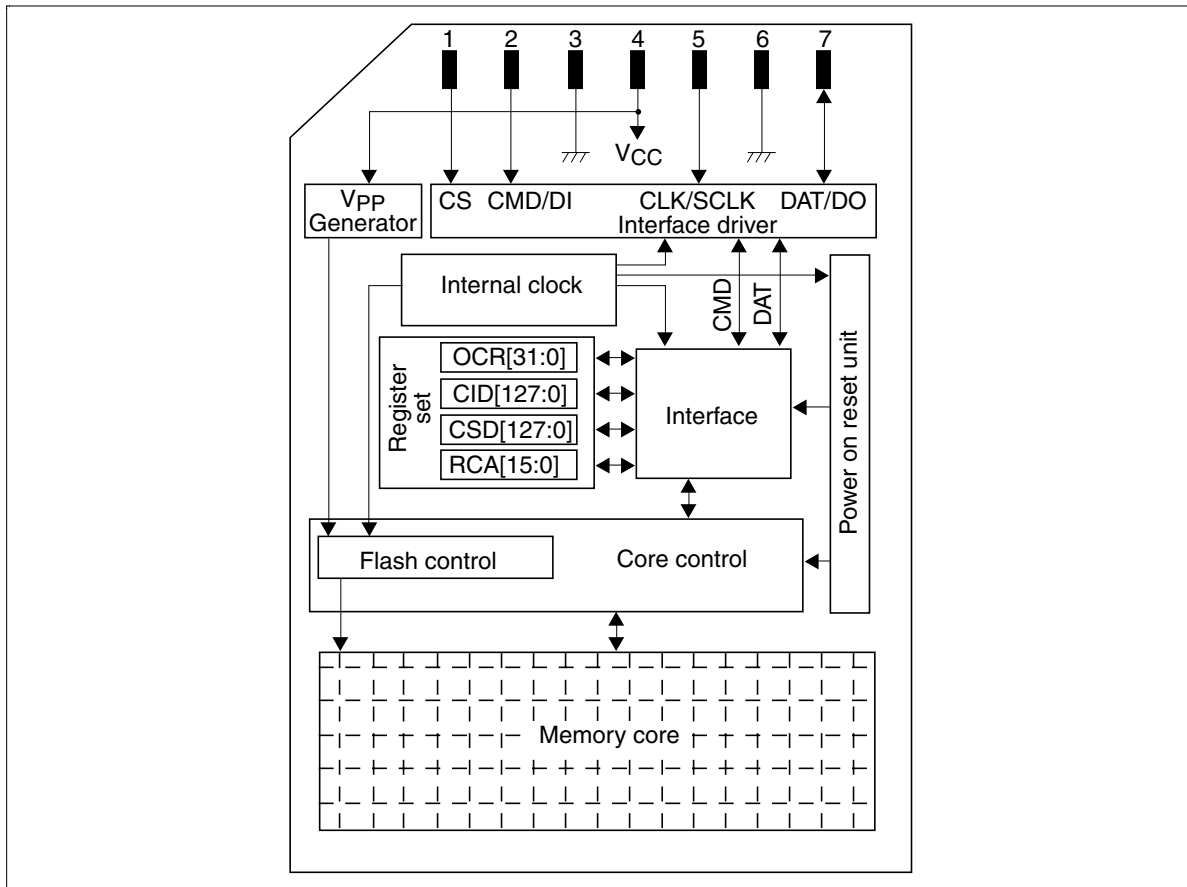

All units in the HB288064MM1 are clocked by an internal clock generator. The Interface driver unit synchronizes the DAT and CMD signals from external CLK to the internal used clock signal. The card is controlled by the three line MultiMediaCard interface containing the signals: CMD, CLK, DAT (refer to Chapter “Interfaces”). For the identification of the HB288064MM1 in a stack of MultiMediaCards a card identification register (CID) and a relative card address register (RCA) is foreseen. An additional register contains different types of operation parameters. This register is called card specific data register (CSD). The communication using the MultiMediaCard lines to access either the memory field or the registers is defined by the MultiMediaCard standard (refer to Chapter “Communication”). The card has its own power on detection unit. No additional master reset signal is required to setup the card after power on. It is protected against short circuit during insertion and removal while the MultiMediaCard system is powered up (refer to Chapter “Power Supply”). No external programming voltage supply is required. The programming voltage is generated on card. HB288064MM1 supports a second interface operation mode the SPI interface mode. The SPI mode is activated if the CS signal is asserted (negative) during the reception of the reset command (CMD0) (refer to Chapter “SPI Communication”).

HB288064MM1

Interface

The HB288064MM1 interface can operate in two different modes:

- MultiMediaCard mode
- SPI mode

Both modes are using the same pins. The default mode is the MultiMediaCard mode. The SPI mode is selected by activating (= 0) the CS signal (Pin1) and sending the CMD0.

MultiMediaCard Mode

In the HB288064MM1, all data is transferred over a minimal number of lines:

- CLK: with each cycle of this signal an one bit transfer on the command and data lines is done. The frequency may vary between zero and the maximum clock frequency. The MultiMediaCard bus master is free to generate these cycles without restrictions in the range of 0 to 20 MHz.
- CMD: is a bidirectional command channel used for card initialization and data transfer commands. The CMD signal has two operation modes: open drain for initialization mode and push pull for fast command transfer. Commands are sent from the MultiMediaCard bus master to the HB288064MM1 and responses vice versa.
- DAT: is a bidirectional data channel with a width of one line. The DAT signal of the HB288064MM1 operates in push pull mode.

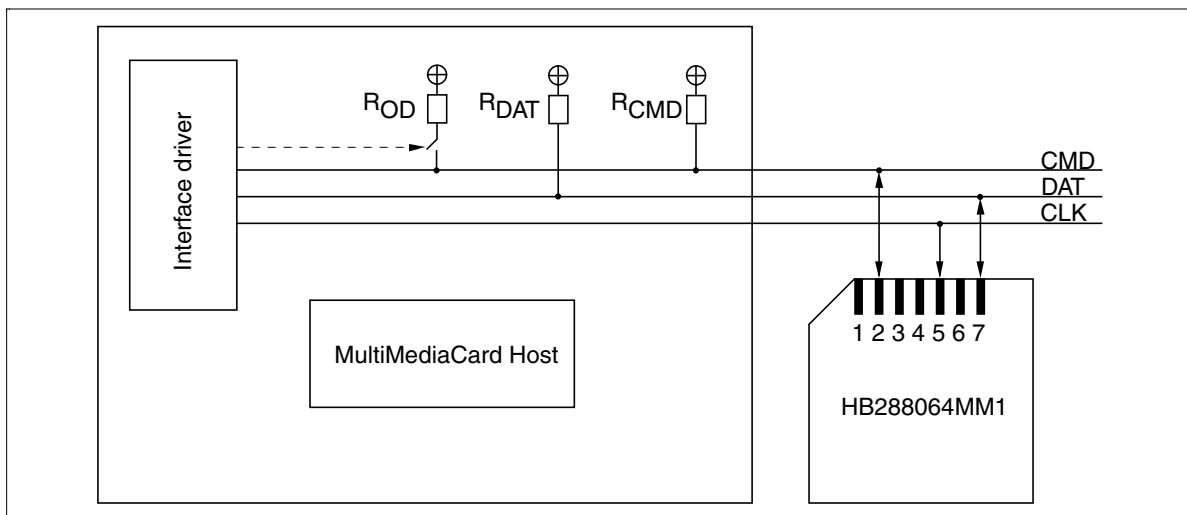

MultiMediaCard Mode Interface

All MultiMediaCards are connected directly to the lines of the MultiMediaCard bus. The following table defines the card contacts.

MultiMediaCard Mode Pad Definition

Pin No.	Name	Type ^{*1}	Description
1	RSV	NC	No connection
2	CMD	I/O/PP/OD	Command/Response
3	V _{SS1}	S	Ground
4	V _{CC}	S	Power supply
5	CLK	I	Clock
6	V _{SS2}	S	Ground
7	DAT	I/O/PP	Data

Note: 1. S: power supply; I: input; O: output; PP: push-pull; OD: open-drain; NC: No connection or V_{IH}

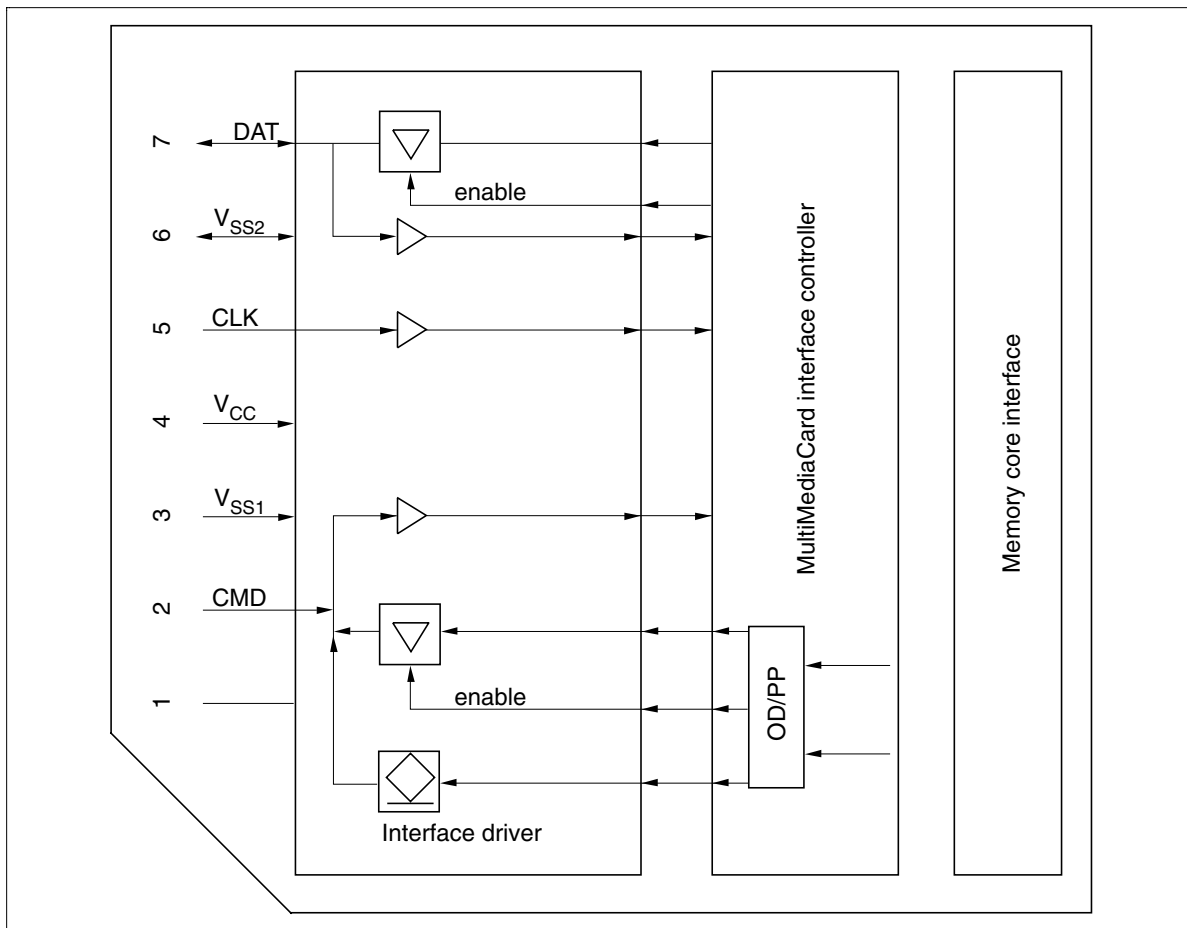

MultiMediaCard Mode I/O-drivers

HB288064MM1

SPI Mode

The Serial Peripheral Interface (SPI) is a general-purpose synchronous serial interface originally found on certain Motorola microcontrollers. The MultiMediaCard SPI interface is compatible with SPI hosts available on the market. As any other SPI device the MultiMediaCard SPI interface consists of the following four signals:

CS: Host to card Chip Select signal.

CLK: Host to card clock signal

Data in: Host to card data signal.

Data out: Card to host data signal.

The MultiMediaCard card identification and addressing methods are replaced by a hardware Chip Select (CS) signal. There are no broadcast commands. For every command, a card (slave) is selected by asserting (active low) the CS signal (refer to Figure “SPI Bus System”). The CS signal must be continuously active for the duration of the SPI transaction (command, response and data). The only exception occurs during card programming, when the host can de-assert the CS signal without affecting the programming process. The bidirectional CMD and DAT lines are replaced by unidirectional data in and data out signals. This eliminates the ability of executing commands while data is being read or written and, therefore, makes the sequential and multi block read/write operations obsolete. Only single block read/write commands are supported by the SPI channel. The SPI interface uses the same seven signals of the standard MultiMediaCard bus (refer to Table “SPI Interface Pin Configuration”).

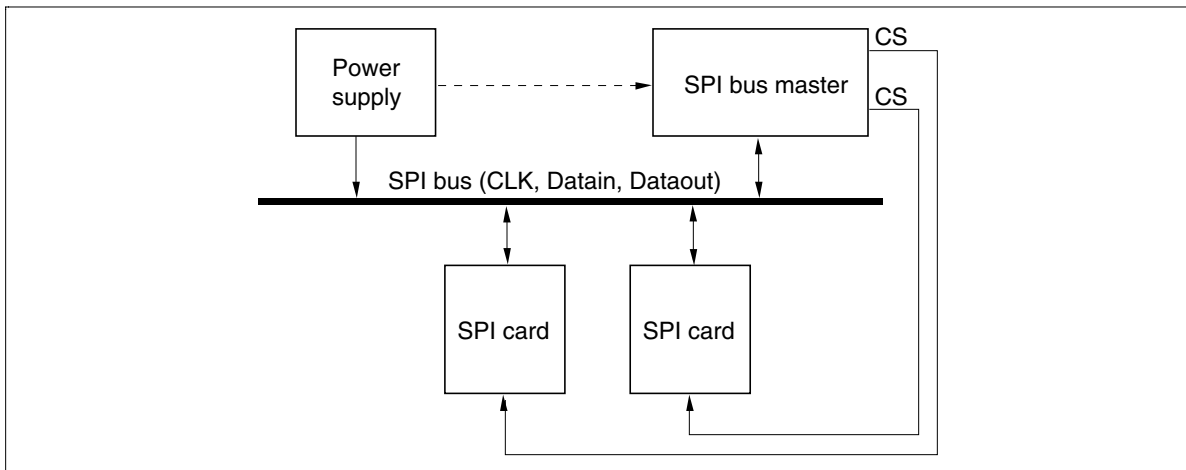

SPI Bus System

SPI Interface Pin Configuration

Pin No.	MultiMediaCard			SPI		
	Name	Type* ¹	Description	Name	Type	Description
1	RSV	NC	Reserved for future use	CS	I	Chip select (neg true)
2	CMD	I/O/PP/OD	Command/Response	DI	I	Data in
3	V _{SS1}	S	Ground	V _{SS}	S	Ground
4	V _{CC}	S	Power supply	V _{CC}	S	Power supply
5	CLK	I	Clock	SCLK	I	Clock
6	V _{SS2}	S	Ground	V _{SS2}	S	Ground
7	DAT	I/O/PP	Data	DO	O/PP	Data out

Note: 1. S: power supply; I: input; O: output; PP: push-pull; OD: open-drain; NC: No connection or V_{IH}

HB288064MM1

Registers

The HB288064MM1 contains the following information registers:

Name	Width	Type	Description
OCR	32	Programmed by the manufacturer. Read only for user	Supported voltage range, card power up status bit
CID	128	Programmed by the manufacturer. Read only for user	Card identification number, card individual number for identification.
RCA	16	Programmed during initialization, not readable	Relative card address, local system address of a card, dynamically assigned by the host during initialization.
CSD	128	Programmed by the manufacturer. Partially programmable by the user.	Card specific data, information about the card operation conditions.

CID and RCA are used for identifying and addressing the HB288064MM1. The third register contains the card specific data record. This record is a set of information fields to define the operation conditions of the HB288064MM1.

For the user the CID and the CSD are read only registers. They are read out by special commands (refer to Chapter “Commands”). The RCA registers are write only registers. Unlike CID and CSD, RCA loses its contents after powering down the card. Its value is reassigned in each initialization cycle. The MultiMediaCard registers usage in SPI mode is summarized in Table “MultiMediaCard Registers in SPI Mode”:

MultiMediaCard Registers in SPI Mode

Name	Available in SPI mode	Width (Bytes)	Description
OCR	Yes	32	Operation condition register.
CID	Yes	16	Card identification data (serial number, manufacturer ID etc.)
RCA	No		
CSD	Yes	16	Card specific data, information about the card operation conditions.

Card Identification (CID)

This register contains the card identification information used during the card identification procedure. It is a 128 bit wide register, one-time programmable by the provider. The CID is divided into eight slices:

CID Fields

Name	Field	Width	CID-slice
Manufacturer ID	MID	8	[127:120]
OEM/Application ID	OID	16	[119:104]
Product name	PNM	48	[103:56]
Product revision	PRV	8	[55:48]
Product serial number	PSN	32	[47:16]
Manufacturing date	MDT	8	[15:8]
CRC checksum	CRC	7	[7:1]
not used, always 1	—	1	[0:0]

The CID has to be error free. To ensure the correctness of the CID a CRC checksum is added to the end of the CID. The CRC checksum is computed by the following formula:

$$\text{CRC Calculation: } G(x) = x^7 + x^3 + 1$$

$$M(x) = \text{CID}[127] * x^{119} + \dots + \text{CID}[8] * x^0$$

$$\text{CRC}[6...0] = \text{Remainder} [(M(x) * x^7) / G(x)]$$

Relative Card Address (RCA)

The 16-bit relative card address register carries the card address assigned by the host during the card identification. This address is used for the addressed host to card communication after the card identification procedure. The default value of the RCA register is 0x0001. The value 0x0000 is reserved to set all cards in Standby State with the command SELECT_DESELECT_CARD (CMD7). The RCA is programmed with the command SET_RELATIVE_ADDRESS (CMD3) during the initialization procedure. The content of this register is lost after power down. The default value is assigned when an internal reset is applied by the power up detection unit of the HB288064MM1.

HB288064MM1

Card Specific Data (CSD)

The card specific data register describes how to access the card content. The CSD defines card operating parameters like maximum data access time, data transfer speed.

The CSD Fields

Name	Field	Width	CSD-slice	Value	Type
CSD structure	CSD_STRUCTURE	2	[127:126]	1	read only
Spec version	SPEC_VERS	4	[125:122]	2	read only
Reserved	—	2	[121:120]	0	read only
Data read access-time-1	TAAC	8	[119:112]	0x0E (1 ms)	read only
Data read access-time-2 in CLK cycles (NAC*100)	NSAC	8	[111:104]	0x01 (100 cycles)	read only
Max. data transfer rate	TRAN_SPEED	8	[103:96]	0x2A (20 Mbit/s)	read only
Card command classes	CCC	12	[95:84]	0x0FF (class 0, 1, 2, 3, 4, 5, 6, 7)	read only
Max. read data block length	READ_BLK_LEN	4	[83:80]	0x9 (512 bytes)	read only
Partial blocks for read allowed	READ_BLK_PARTIAL	1	[79:79]	'1'*1 (Enabled)	read only
Write block misalignment	WRITE_BLK_MISALIGN	1	[78:78]	'0' (Disabled)	read only
Read block misalignment	READ_BLK_MISALIGN	1	[77:77]	'0' (Disabled)	read only
DSR implemented	DSR_IMP	1	[76:76]	'0' (Disabled)	read only
Reserved	—	2	[75:74]	0	read only
Device size	C_SIZE	12	[73:62]	0x7A7 (64 MByte)*2	read only
Max. read current at V _{DD} min	VDD_R_CURR_MIN	3	[61:59]	0x5 (35 mA)	read only
Max. read current at V _{DD} max	VDD_R_CURR_MAX	3	[58:56]	0x5 (45 mA)	read only
Max. write current at V _{DD} min	VDD_W_CURR_MIN	3	[55:53]	0x5 (35 mA)	read only
Max. write current at V _{DD} max	VDD_W_CURR_MAX	3	[52:50]	0x5 (45 mA)	read only
Device size multiplier	C_SIZE_MULT	3	[49:47]	4 (64 MByte)*3	read only
Erase sector size	SECTOR_SIZE	5	[46:42]	0 (512 Bytes)	read only
Erase group size	ERASE_GRP_SIZE	5	[41:37]	0x0F (8 kByte)	read only

HB288064MM1

Name	Field	Width	CSD-slice	Value	Type
Write protect group size	WP_GRP_SIZE	5	[36:32]	0x01 (16 kByte)	read only
Write protect group enable	WP_GRP_ENABLE	1	[31:31]	'1'	read only
Manufacturer default ECC	DEFAULT_ECC	2	[30:29]	0	read only
Write speed factor	R2W_FACTOR	3	[28:26]	2 (4)	read only
Max. write data block length	WRITE_BLK_LEN	4	[25:22]	9 (512 Bytes)	read only
Partial blocks for write allowed	WRITE_BLK_PARTIAL	1	[21:21]	'0'	read only
Reserved	—	5	[20:16]	0	read only
File format group	FILE_FORMAT_GRP	1	[15:15]	×	read/write
Copy flag (OTP)	COPY	1	[14:14]	× ⁴	read/write
Permanent write protection	PERM_WRITE_PROTECT	1	[13:13]	×	read/write
Temporary write protection	TMP_WRITE_PROTECT	1	[12:12]	×	read/write/erase
File format	FILE_FORMAT	2	[11:10]	×	read/write
ECC code	ECC	2	[9:8]	×	read/write/erase
CRC	CRC	7	[7:1]	×	read/write/erase
Not used, always 1	—	0	[0:0]	1	read only

Notes: 1. Access time from block to block within sector is 1 μ s. For blocks smaller than 256 Byte, it is 62 μ s.

2. This field is depended on the model. Refer to also C_SIZE_MULT

3. This field is depended on the model. Refer to also C_SIZE

4. × means user programmable

Some of the CSD fields are one-time or multiple programmable by the customer or provider. All other field values are fixed. The following section describes the CSD fields and their values for the HB288064MM1:

- CSD_STRUCTURE

CSD Register Structure

CSD_STRUCTURE

CSD register structure

'01'

CSD version No. 1.1

The CSD version of the HB288064MM1 is related to the “MultiMediaCard system specification, Version 2.11”. The parameter CSD_STRUCTURE has permanently the value 1.

HB288064MM1

- SPEC_VERS

Defines the Spec version supported by the card. It includes the commands set definition and the definition of the card responses. The card identification procedure is compatible for all spec versions!

SPEC Version

SPEC_VERS	System specification version number
'0010'	System specification version 2.11

The Spec version of the HB288064MM1 is related to the “MultiMediaCard system specification, Version 2.11”. The parameter SPEC_VERS has permanently the value 2.

- TAAC

Defines the asynchronous data access time:

TAAC Access Time Definition

TAAC bit	Description	Values
2:0	time exponent	0 = 1 ns, 1 = 10 ns, 2 = 100 ns, 3 = 1 μ s, 4 = 10 μ s, 5 = 100 μ s, 6 = 1 ms, 7 = 10 ms
6:3	time mantissa	0 = reserved, 1 = 1.0, 2 = 1.2, 3 = 1.3, 4 = 1.5, 5 = 2.0, 6 = 2.5, 7 = 3.0, 8 = 3.5, 9 = 4.0, A = 4.5, B = 5.0, C = 5.5, D = 6.0, E = 7.0, F = 8.0
7	reserved	always '0'

The value for the asynchronous delay for the HB288064MM1 is 1 ms. The coded TAAC value is 0x0E (= 1 ms). For more details refer to Chapter “Operating Characteristics”.

- NSAC

Defines the worst case for the synchronous data access time. N_{AC} is defined as $100 \cdot NSAC$ clock cycles, where NSAC presents a binary value. Max. value for the data access time N_{AC} is 25.6k clock cycles. The total access time is the sum of both TAAC and $N_{AC} \cdot \text{clock period}$. The value of NSAC for the HB288064MM1 is 0x01 (100 cycles). For more details refer to Chapter “Operating Characteristics”.

- TRAN_SPEED

The following table defines the maximum data transfer rate TRAN_SPEED:

Maximum Data Transfer Rate Definition

TRAN_SPEED bit	Description
2:0	transfer rate exponent 0 = 100 kbit/s, 1 = 1 Mbit/s, 2 = 10 Mbit/s, 3 = 100 Mbit/s, 4...7 = reserved
6:3	time mantissa 0x0 = reserved, 0x1 = 1.0, 0x2 = 1.2, 0x3 = 1.3, 0x4 = 1.5, 0x5 = 2.0, 0x6 = 2.5, 0x7 = 3.0, 0x8 = 3.5, 0x9 = 4.0, 0xA = 4.5, 0xB = 5.0, 0xC = 5.5, 0xD = 6.0, 0xE = 7.0, 0xF = 8.0
7	reserved = '0'

The HB288064MM1 supports a transfer rate between 0 and 20 Mbit/s. The parameter TRAN_SPEED is 0x2A.

- CCC

The MultiMediaCard command set is divided into subsets (command classes). The card command class register CCC defines which command classes are supported by this card. A set CCC bit means that the corresponding command class is supported. For command class definition refer to Table “HB288064MM1 Command Classes”.

Supported Card Command Classes

CCC bit	Supported card command classes
0	class0
1	class1
.....
11	class11

The HB288064MM1 supports the command classes 0, 1, 2, 3, 4, 5, 6 and 7. The parameter CCC is permanently assigned to the value 0x0FF.

HB288064MM1

- READ_BLK_LEN

The data block length is computed as $2^{\text{READ_BLK_LEN}}$.

Data Block Length

READ_BLK_LEN	Block length	Remark
0	$2^0 = 1$ byte	
1	$2^1 = 2$ bytes	
.....	
11	$2^{11} = 2048$ bytes	
12–15	reserved	

The block length might therefore be in the range 1, 2, 4...2048 bytes. This parameter defines the block length if READ_BLK_PARTIAL is not set. If READ_BLK_PARTIAL is set this parameter contains the maximum allowed value of the block length in bytes. All block lengths between one and this value are permitted. The actual block size is programmed by the command SET_BLOCKLEN (CMD16). The HB288064MM1 supports block lengths from 1 byte up to 2048 bytes. The parameter READ_BLK_LEN is permanently assigned to the value 0x9.

- READ_BLK_PARTIAL

READ_BLK_PARTIAL defines whether partial block sizes can be used in block read and block write commands. READ_BLK_PARTIAL = 0 means that only the block size defined by READ_BLK_LEN can be used for block-oriented data transfers. READ_BLK_PARTIAL = 1 means that smaller blocks can be used as well. The minimum block size will be equal to minimum addressable unit (one byte). The HB288064MM1 supports partial block read. The parameter READ_BLK_PARTIAL is permanently assigned to the value '1'.

- WRITE_BLK_MISALIGN

Defines if the data block to be written by one command can be spread over more than one physical blocks of the memory device. The size of the memory block is defined in WRITE_BLK_LEN. WRITE_BLK_MISALIGN is permanently assigned to the value '0', signalling that crossing physical block boundaries is not allowed.

- READ_BLK_MISALIGN

Defines if the data block to be read by one command can be spread over more than one physical block of the memory device. The size of the data block is defined in READ_BLK_LEN. READ_BLK_MISALIGN = 0 signals that crossing physical block boundaries is not allowed. READ_BLK_MISALIGN = 1 signals that crossing physical block boundaries is allowed. The HB288064MM1 does not support read block operations with boundary crossing. The parameter READ_BLK_MISALIGN is permanently assigned to the value '0'.

- **DSR_IMP**

Defines if the configurable driver stage option is integrated on the card or not. If implemented a driver stage register (DSR) must be implemented also.

DSR Implementation

DSR_IMP	DSR type
0	no DSR implemented
1	DSR implemented

The HB288064MM1 output drivers are not configurable. The parameter DSR_IMP is permanently assigned to the value '0'.

- **C_SIZE**

This parameter is used to compute the card capacity. The memory capacity of the card is computed from the entries C_SIZE, C_SIZE_MULT and READ_BLK_LEN as follows:

$$\text{memory capacity} = \text{BLOCKNR} * \text{BLOCK_LEN}$$

Where

$$\text{BLOCKNR} = (\text{C_SIZE} + 1) * \text{MULT}$$

$$\text{MULT} = 2^{\text{C_SIZE_MULT} + 2} \quad (\text{C_SIZE_MULT} < 8)$$

$$\text{BLOCK_LEN} = 2^{\text{READ_BLK_LEN}} \quad (\text{READ_BLK_LEN} < 12)$$

Therefore, the maximal capacity which can be coded is $4096 * 512 * 512 = 1$ GBytes.

Example: A 64 MBytes card with BLOCK_LEN = 512 can be coded with C_SIZE_MULT = 4 and C_SIZE = 1959.

The card capacity is 64 MBytes.

The value of the parameter C_SIZE used in the formula above for the HB288064MM1 is 0x7A7.

HB288064MM1

- VDD_R_CURR_MIN, VDD_W_CURR_MIN

The maximum supply current at the minimum supply voltage V_{CC} (2.7 V) is coded as follows:

Maximum Supply Current Consumption at $V_{CC} = 2.7$ V

VDD_R_CURR_MIN VDD_W_CURR_MIN	Code for current consumption at 2.7 V
2:0	0 = 0.5 mA; 1 = 1 mA; 2 = 5 mA; 3 = 10 mA; 4 = 25 mA; 5 = 35 mA; 6 = 60 mA; 7 = 100 mA

The parameter VDD_R_CURR_MIN and VDD_W_CURR_MIN are permanently assigned to the value 5 (35 mA).

- VDD_R_CURR_MAX, VDD_W_CURR_MAX

The maximum supply current at the maximum supply voltage V_{CC} (3.6 V) is coded as follows:

Maximum Supply Current Consumption at $V_{CC} = 3.6$ V

VDD_R_CURR_MAX VDD_W_CURR_MAX	Code for current consumption at 3.6 V
2:0	0 = 1 mA; 1 = 5 mA; 2 = 10 mA; 3 = 25 mA; 4 = 35 mA; 5 = 45 mA; 6 = 80 mA; 7 = 200 mA

The parameter VDD_R_CURR_MAX and VDD_W_CURR_MAX are permanently assigned to the value 5 (45 mA). For more details refer to Chapter “Characteristics”.

- **C_SIZE_MULT**

This parameter is used for coding a factor **MULT** for computing the total device size (refer to “**C_SIZE**”). The factor **MULT** is defined as $2^{C_SIZE_MULT+2}$.

Multiply Factor for the Device Size

C_SIZE_MULT	MULT	Remark
0	$2^2 = 4$	
1	$2^3 = 8$	
2	$2^4 = 16$	
3	$2^5 = 32$	
4	$2^6 = 64$	
5	$2^7 = 128$	
6	$2^8 = 256$	
7	$2^9 = 512$	

The card capacity is 64 MBytes. The value of the parameter **C_SIZE_MULT** used in the formula to calculate the card capacity (refer to parameter “**C_SIZE**”) for the HB288064MM1 is 4 (multiplier = 64).

- **SECTOR_SIZE**

The size of an erasable or write protection sector. The content of this register is a binary coded value defining the number of write blocks (refer to “**WRITE_BLK_LEN**”) of a sector. The sector size of the HB288064MM1 is set to 0 (= one write block = 512 bytes).

- **ERASE_GROUP_SIZE**

The size of an erasable group. The content of this register is a binary coded value defining the number of sectors (refer to “**SECTOR_SIZE**”) of a group. This parameters value is 15 which means a group size of $(15+1)*512$ bytes = 8 kByte.

- **WP_GRP_SIZE**

The size of a write protection group. The content of this register is a binary coded value defining the number of sectors (refer to “**SECTOR_SIZE**”) of a group. This parameters value is 1 which means a group size of $(1+1)*(ERASE_GROUP_SIZE) = 16$ kByte.

- **WP_GRP_ENABLE**

The value is set to ‘1’, meaning group write protection is enabled.

HB288064MM1

- **DEFAULT_ECC**

Set by the card manufacturer and defines the ECC code which is recommended to use (e.g. the device is tested for). The value is set to '0', indicating that no designated ECC is recommended.

- **R2W_FACTOR**

Defines the typical block program time as a multiple of the read access time. The following table defines the field format.

R2W_FACTOR

R2W_FACTOR	Multiples of read access time
0	1
1	2 (write half as fast as read)
2	4
3	8
4	16
5	32
6, 7	reserved

This parameter value is 2 for the HB288064MM1.

- **WRITE_BLK_LEN**

The data block length is computed as $2^{\text{WRITE_BLK_LEN}}$.

Data Block Length

WRITE_BLK_LEN	Block length	Remark
0	$2^0 = 1$ byte	
1	$2^1 = 2$ bytes	
.....	
11	$2^{11} = 2048$ bytes	
12–15	reserved	

The block length might therefore be in the range 1, 2, 4...2048 bytes. This parameter defines the block length if WRITE_BLK_PARTIAL is not set. If WRITE_BLK_PARTIAL is set this parameter contains the maximum allowed value of the block length in bytes. All block lengths between one and this value are permitted. The actual block size is programmed by the command SET_BLOCKLEN (CMD16). The HB288064MM1 supports blocks with the length 512 bytes. The parameter WRITE_BLK_LEN is permanently assigned to the value 0x9.

- **WRITE_BLK_PARTIAL**

WRITE_BLK_PARTIAL defines whether partial block sizes can be used in block read and block write commands. WRITE_BLK_PARTIAL = 0 means that only the block size defined by WRITE_BLK_LEN can be used for block-oriented data transfers. WRITE_BLK_PARTIAL = 1 means that smaller blocks can be used as well. The minimum block size will be equal to minimum addressable unit (one byte). The HB288064MM1 supports no partial block write. The parameter WRITE_BLK_PARTIAL is permanently assigned to the value '0'.

- **FILE_FORMAT_GRP**

Indicates the selected group of file formats. This field is read-only for ROM. The usage of this field is shown in table "File_Formats".

- **COPY**

Defines if the contents are an original (COPY = "0") or a copy (= "1"). The COPY bit for OTP and MTP devices, sold to end consumers, is set to "1" which identifies the card content as a copy. The COPY bit is a one time programmable bit, being set by the customer

- **PERM_WRITE_PROTECT**

Permanently protects the whole card content against overwriting or erasing (all write and erase commands for this card is permanently disabled). This parameter is one-time programmable by the customer. The default value is '0' (not protected).

- **TMP_WRITE_PROTECT**

Temporarily protects the whole card content from being overwritten or erased (all write and erase commands for this card are temporarily disabled). This parameter is programmable by the customer. The default value is '0' (not protected).

- **FILE_FORMAT**

Indicates the file format on the card. This field is read-only for ROM. The following formats are defined:

File_Formats

FILE_FORMAT_GRP	FILE_FORMAT	Type
0	0	Hard disk-like file system with partition table
0	1	DOS FAT (floppy-like) with boot sector only (no partition table)
0	2	Universal File Format
0	3	Others/Unknown
1	0, 1, 2, 3	Reserved

HB288064MM1

- ECC

Defines the ECC code that was used for storing data on the card. This field is used by the host (or application) to decode the user data. The following table defines the field format.

ECC Type

ECC	ECC type	Maximum number of correctable bits
0	none (default)	none
1	BCH (542,512)	3
2–15	reserved	—

The content provider or customer defines which kind of error correction may be used to protect the contents of the HB288064MM1. This value is programmable.

- CRC

The CRC register contains the check sum for the CSD content. The check sum is computed by the following formulas: Generator polynomial:

$$G(x) = x^7 + x^3 + 1$$

$$M(x) = \text{CSD}[127] * x^{119} + \dots + \text{CSD}[8] * x^0 \quad \text{CRC}[6\dots0] = \text{Remainder} [(M(x) * x^7) / G(x)]$$

The user has to recalculate a new CRC after defining a new CSD.

MultiMediaCard Communication

All communication between host and cards is controlled by the host (master). The host sends commands and, depending on the command, receives a corresponding response from the selected card. In this chapter the commands to control the HB288064MM1, the card responses and the contents of the status and error field included in the responses, are defined.

Memory Array Partitioning

The basic unit of data transfer to/from the MultiMediaCard is one byte. All data transfer operations which require a block size always define block lengths as integer multiples of bytes. Some special functions need other partition granularity. For block-oriented commands, the following definition is used:

- **Block:** is the unit which is related to the block-oriented read and write commands. Its size is the number of bytes which will be transferred when one block command is sent by the host. The size of a block is either programmable or fixed. The information about allowed block sizes and the programmability is stored in the CSD.

For devices which have erasable memory cells, special erase commands are defined. The granularity of the erasable units is in general not the same as for the block-oriented commands:

- **Sector:** is the unit which is related to the erase commands. Its size is the number of blocks which will be erased in one portion. The size of a sector is fixed for each device. The information about the sector size (in blocks) is stored in the CSD.
- **Group:** is a number of sectors. Its size is the number of consecutive sectors which will be erased at once. The size of a group is fixed for each device. The information about the size is stored in the CSD.

For devices which include a write protection:

- **WP-Group:** is the minimal unit which may have individual write protection. Its size is the number of sectors which will be write protected by one bit. The size of a WP-group is fixed for each device. The information about the size is stored in the CSD.

Each erasable unit (group and sector) has a special “tag” bit. This bit may be set or cleared by special commands to tag the unit. All tagged units will be erased in parallel by one erase command following a number of tag commands. All tag bits are cleared by each command except a tag or untag command. Therefore, immediately after a sequence of tag commands an erase command has to be sent by the host. Commands others than tagging or erasing abort a tag-erase cycle irregularly.

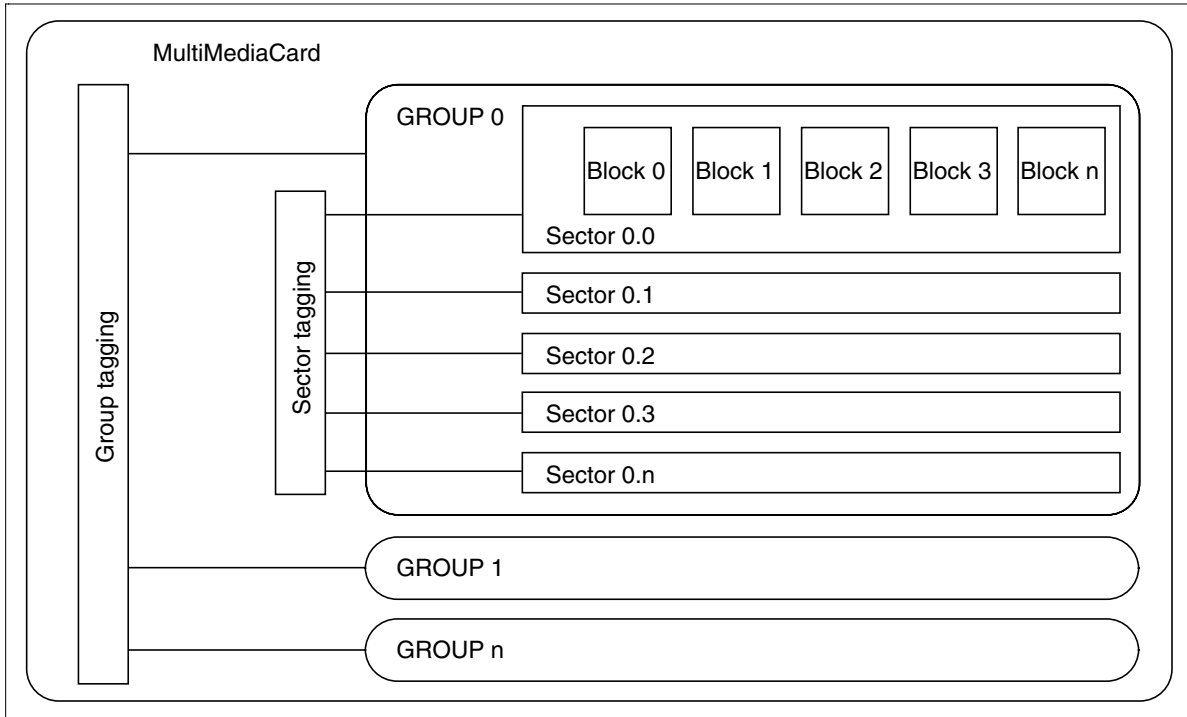

Erase Tagging Hierarchy

Each WP-group may have an additional write protection bit. The write protection bits are programmable via special commands (refer to Chapter “Commands”). Both functions are optional and only useful for writable/erasable devices. The write protection may also be useful for multi type MultiMediaCards (e.g. a ROM - Flash combination). The information about the availability is stored in the CSD.

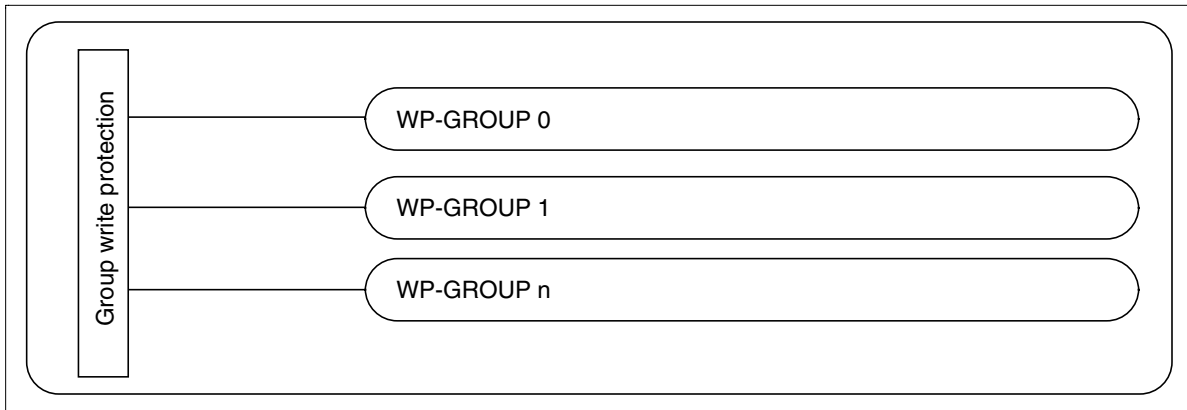

Write Protection

Commands

The command set of the MultiMediaCard system is divided into classes corresponding to the type of card (see also [1]). The HB288064MM1 supports the following command classes:

HB288064MM1 Command Classes (Class 0 to Class 2)

Card command class (CCC)	Class description	Supported commands													
		0	1	2	3	4	7	9	10	11	12	13	15	16	17
Class 0	basic	+	+	+	+	+	+	+	+		+	+	+		
Class 1	stream read									+					
Class 2	block read												+	+	+

HB288064MM1 Command Classes (Class 3 to Class 8)

Card command class (CCC)	Class description	Supported commands														
		20	24	25	26	27	28	29	30	32	33	34	35	36	37	38
Class 3	stream write	+														
Class 4	block write		+	+	+	+										
Class 5	erase									+	+	+	+	+	+	+
Class 6	write protection						+	+	+							
Class 7	lock card															+

Class 0 is mandatory and supported by all cards. It represents the card identification and initialization commands, which are intended to handle different cards and card types on the same bus lines. The Card Command Class (CCC) is coded in the card specific data register of each card, so that the host knows how to access the card. There are four kinds of commands defined on the MultiMediaCard bus:

- broadcast commands (bc) sent on CMD line, no response
- broadcast commands with response (bcr) sent on CMD line, response (all cards simultaneously) on CMD line
- addressed (point-to-point) commands (ac) sent on CMD line, response on CMD line
- addressed (point-to-point) data transfer commands (adtc) sent on CMD line, response on CMD line, data transfer on DAT line

HB288064MM1

The command transmission always starts with the MSB. Each command starts with a start bit and ends with a CRC command protection field followed by an end bit. The length of each command frame is fixed to 48 bits (2.4 μ s at 20 MHz):

0	1	bit5...bit0	bit31...bit0	bit6...bit0	1
start bit	host	command	argument	CRC*1	end bit

Note: 1. (Cyclic Redundancy Check)

The start bit is always '0' in command frames (sent from host to MultiMediaCard). The host bit is always '1' for commands. The command field contains the binary coded command number. The argument depends on the command (refer to Table "Basic Commands (class 0) and Table "Block-Oriented Read Commands (class 2)"). The CRC field is defined in Chapter "Cyclic Redundancy Check (CRC)". The HB288064MM1 supports the following MultiMediaCard commands:

Read, Write and Erase Time-out Conditions

The times after which a time-out condition for read/write/erase operations occurs are (card independent) 10 times longer than the access/program times for these operations given below. A card shall complete the command within this time period, or give up and return an error message. If the host does not get a response within the defined time-out it should assume the card is not going to respond anymore and try to recover (e.g. reset the card, power cycle, reject, etc.). The typical access and program times are defined as follows:

Read

The read access time is defined as the sum of the two times given by the CSD parameters TAAC and NSAC (refer to Table “Card Specific Data (CSD)”). These card parameters define the typical delay between the end bit of the read command and the start bit of the data block. This number is card dependent and should be used by the host to calculate throughput and the maximal frequency for stream read.

Write

The R2W_FACTOR field in the CSD is used to calculate the typical block program time obtained by multiplying the read access time by this factor. It applies to all write/erase commands (e.g. SET(CLEAR)_WRITE_PROTECT, PROGRAM_CSD(CID) and the block write commands). It should be used by the host to calculate throughput and the maximal frequency for stream write.

Erase

The duration of an erase command will be (order of magnitude) the number of sectors to be erased multiplied by the block write delay.

HB288064MM1

Basic Commands (class 0) and Read Stream Command (class 1)

CMD index	Type	Argument	Resp	Abbreviation	Command description
CMD0	bc	[31:0] stuff bits	—	GO_IDLE_STATE	resets all cards to Idle State
CMD1	bcr	[31:0] OCR without busy	R3	SEND_OP_COND	checks for cards not supporting the full range of 2.0 V to 3.6 V. After receiving CMD1 the card sends an R3 response (refer to Chapter “Responses”).
CMD2	bcr	[31:0] stuff bits	R2	ALL_SEND_CID	asks all cards in ready state to send their CID* ¹ numbers on CMD-line
CMD3	ac	[31:16] RCA [15:0] stuff bits	R1	SET_RELATIVE_A DDR	assigns relative address to the card in identification state.
CMD4	bc	[31:16] DSR [15:0] stuff bits	—	SET_DSR	programs the DSR of all cards in stand-by state.
CMD7	ac	[31:16] RCA [15:0] stuff bits	R1 (only the selected card)	SELECT/ DESELECT_CARD	command toggles a card between the standby and transfer states or between the programming and disconnect state. In both cases the card is selected by its own relative address while deselecting the prior selected card. Address 0 deselects all.
CMD9	ac	[31:16] RCA [15:0] stuff bits	R2	SEND_CSD	asks the addressed card to send its card-specific data (CSD)* ² on CMD-line.
CMD10	ac	[31:16] RCA [15:0] stuff bits	R2	SEND_CID	asks the addressed card to send its card identification (CID) on CMD- line.
CMD11	adtc	[31:0] data address	R1	READ_DAT_UNTIL _STOP	reads data stream from the card, starting at the given address, until a STOP_TRANSMISSION follows.
CMD12	ac	[31:0] stuff bits	R1b* ³	STOP_TRANSMISSION	forces the card to stop transmission
CMD13	ac	[31:16] RCA [15:0] stuff bits	R1	SEND_STATUS	Asks the addressed card to send its status register.
CMD15	ac	[31:16] RCA [15:0] stuff bits	—	GO_INACTIVE_STATE	Sets the card to inactive state in order to protect the card stack against communications breakdowns.

- Notes:
1. CID register consists of 128 bits (starting with MSB, it is preceded by an additional start bit, ends with an end bit)
 2. CSD register consists of 128 bits (starting with MSB, it is preceded by an additional start bit, ends with an end bit)
 3. This command is indicating the busy status of the MultiMediaCard via the data channel.

Block-Oriented Read Commands (class 2)

CMD index	Type	Argument	Resp	Abbreviation	Command description
CMD16	ac	[31:0] block length	R1	SET_BLOCKLEN	Selects a block length (in bytes) for all following block commands (read and write). ^{*1}
CMD17	adtc	[31:0] data address	R1	READ_SINGLE_BLOCK	Reads a block of the size selected by the SET_BLOCKLEN command. ^{*2}
CMD18	adtc	[31:0] data address	R1	READ_MULTIPLE_BLOCK	Continuously send blocks of data until interrupted by a stop.

- Notes: 1. The default block length is as specified in the CSD.
2. The data transferred must not cross a physical block boundary unless RD_BLK_MISALIGN is set in the CSD.

Stream Write Command (class 3)

CMD index	Type	Argument	Resp	Abbreviation	Command description
CMD20	adtc	[31:0] data address	R1	WRITE_DATA_UNTIL_STOP	writes data stream from the host, starting at the given address, until a STOP_TRANSMISSION follows.

Block-Oriented Write Commands (class 4)

CMD index	Type	Argument	Resp	Abbreviation	Command description
CMD24	adtc	[31:0] data address	R1	WRITE_BLOCK	Writes a block of the size selected by the SET_BLOCKLEN command. ^{*1}
CMD25	adtc	[31:0] data address	R1	WRITE_MULTIPLE_BLOCK	Continuously writes blocks of data until a STOP_TRANSMISSION follows.
CMD26	adtc	[31:0] stuff bits	R1	PROGRAM_CID	Programming of the card identification register. This command is only done once per MultiMediaCard card. The card has some hardware to prevent this operation after the first programming. Normally this command is reserved for the manufacturer.
CMD27	adtc	[31:0] stuff bits	R1	PROGRAM_CSD	Programming of the programmable bits of the CSD.

- Note: 1. The data transferred must not cross a physical block boundary unless WRITE_BLK_MISALIGN is set in the CSD.

HB288064MM1

Erase Commands (class 5)

CMD index	Type	Argument	Resp	Abbreviation	Command description
CMD32	ac	[31:0] data address	R1	TAG_SECTOR_ST ART	Sets the address of the first sector of the erase group.
CMD33	ac	[31:0] data address	R1	TAG_SECTOR_EN D	Sets the address of the last sector in a continuous range within the selected erase group to be selected for erase, or the address of a single sector to be selected.
CMD34	ac	[31:0] data address	R1	UNTAG_SECTOR	Removes one previously selected sector from the erase selection.
CMD35	ac	[31:0] data address	R1	TAG_ERASE_GRO UP_START	Sets the address of the first erase group within a range to be selected for erase
CMD36	ac	[31:0] data address	R1	TAG_ERASE_GRO UP_END	Sets the address of the last erase group within a continuous range to be selected for erase
CMD37	ac	[31:0] data address	R1	UNTAG_ERASE_G ROUP	Removes one previously selected erase group from the erase selection
CMD38	ac	[31:0] stuff bits	R1b	ERASE	Erases all previously selected sectors

Write Protection Commands (class 6)

CMD index	Type	Argument	Resp	Abbreviation	Command description
CMD28	ac	[31:0] data address	R1b	SET_WRITE_PROT	if the card has write protection features, this command sets the write protection bit of the addressed group. The properties of write protection are coded in the card specific data (WP_GRP_SIZE).
CMD29	ac	[31:0] data address	R1b	CLR_WRITE_PROT	if the card provides write protection features, this command clears the write protection bit of the addressed group.
CMD30	adtc	[31:0] write protect data address	R1	SEND_WRITE_PR OT	if the card provides write protection features, this command asks the card to send the status of the write protection bits.*1
CMD31	reversed				

Note: 1. 32 write protection bits (representing 32 write protect groups starting at the specified address) followed by 16 CRC bits are transferred in a payload format via the data line. The last (least significant) bit of the protection bits corresponds to the first addressed group. If the addresses of the last groups are outside the valid range, then the corresponding write protection bits shall be set to zero.

Lock Card Command (class 7)

CMD index	Type	Argument	Resp	Abbreviation	Command description
CMD42	adtc	[31:0] stuff bits	R1b	LOCK_UNLOCK	used to set/reset the password or lock/unlock the card. The size of the data block is set by the SET_BLOCK_LEN command.

Card identification mode

All the data communication in the card identification mode uses only the command line (CMD).

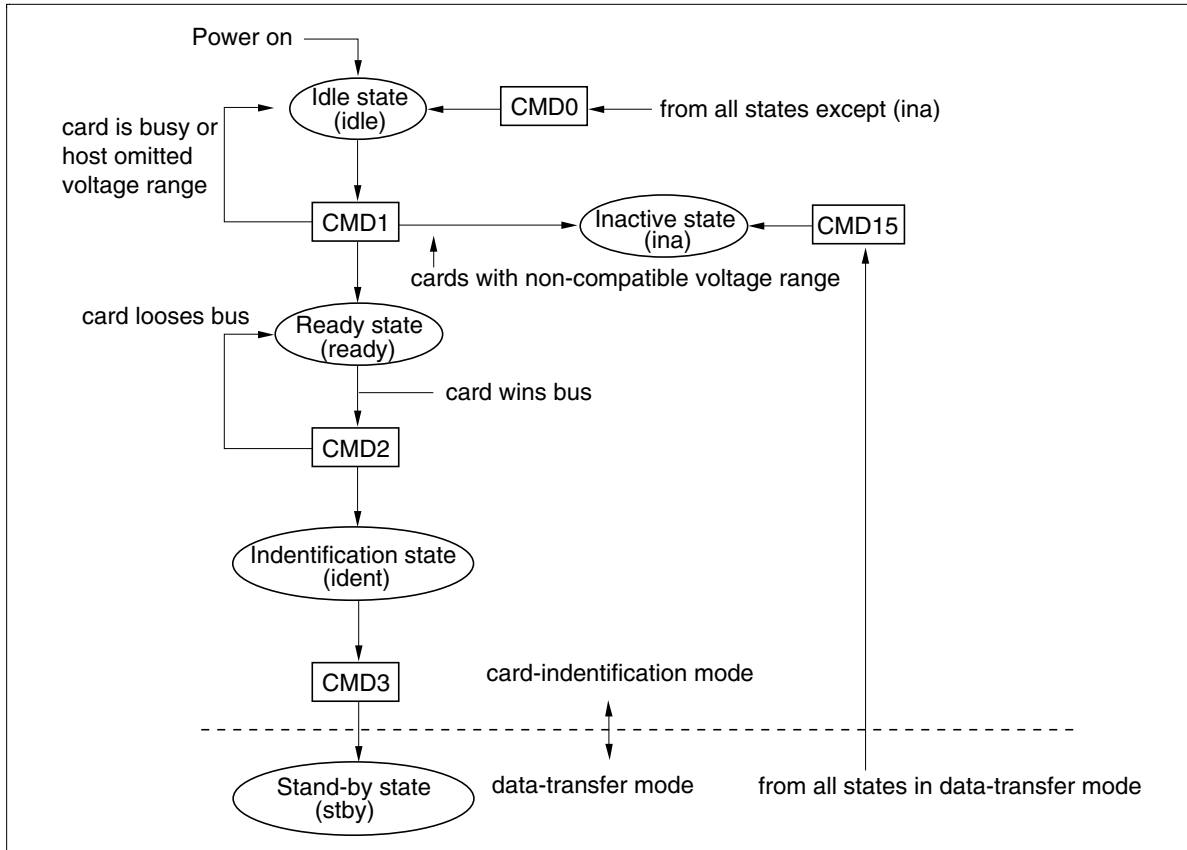

MultiMediaCard State Diagram (Card Identification Mode)

The host starts the card identification process in open drain mode with the identification clock rate f_{OD} (generated by a push pull driver stage). The open drain driver stages on the CMD line allow the parallel card operation during card identification. After the bus is activated the host will request the cards to send their valid operation conditions with the command SEND_OP_COND (CMD1). Since the bus is in open drain mode, as long as there is more than one card with operating conditions restrictions, the host gets in the response to the CMD1 a “wired or” operation condition restrictions of those cards. The host then must pick a common denominator for operation and notify the application that cards with out of range parameters (from the host perspective) are connected to the bus. Incompatible cards go into Inactive State (refer to also Chapter “Operating Voltage Range Validation”). The busy bit in the CMD1 response can be used by a card to tell the host that it is still working on its power-up/reset procedure (e.g. downloading the register information from memory field) and is not ready yet for communication. In this case the host must repeat CMD1 until the busy bit is cleared. After an operating mode is established, the host asks all cards for their unique card identification (CID) number with the broadcast command ALL_SEND_CID (CMD2). All not already identified cards (i.e. those which are in Ready State) simultaneously start sending their CID numbers serially, while bit-wise monitoring their outgoing bitstream. Those cards, whose outgoing CID

bits do not match the corresponding bits on the command line in any one of the bit periods, stop sending their CID immediately and must wait for the next identification cycle (cards stay in the Ready State). There should be only one card which successfully sends its full CID-number to the host. This card then goes into the Identification State. The host assigns to this card (using CMD3, SET_RELATIVE_ADDR) a relative card address (RCA, shorter than CID), which will be used to address the card in future communication (faster than with the CID). Once the RCA is received the card transfers to the Standby State and does not react to further identification cycles. The card also switches the output drivers from the open-drain to the push-pull mode in this state. The host repeats the identification process as long as it receives a response (CID) to its identification command (CMD2). When no card responds to this command, all cards have been identified. The time-out condition to recognize this, is waiting for the start bit for more than 5 clock periods after sending CMD2.

Operating Voltage Range Validation

The MultiMediaCard standards operating range validation is intended to support reduced voltage range MultiMediaCards. The HB288064MM1 supports the range of 2.7 V to 3.6V supply voltage. So the HB288064MM1 sends a R3 response to CMD1 which contains an OCR value of 0x80FF8000 if the busy flag is set to “ready” or 0x00FF8000 if the busy flag is active (refer to Chapter “Responses”). By omitting the voltage range in the command, the host can query the card stack and determine the common voltage range before sending out-of-range cards into the Inactive State. This bus query should be used if the host is able to select a common voltage range or if a notification to the application of non usable cards in the stack is desired. Afterwards, the host must choose a voltage for operation and reissue CMD1 with this condition, sending incompatible cards into the Inactive State.

HB288064MM1

Data Transfer Mode

When in Standby State, both CMD and DAT lines are in the push-pull mode. As long as the content of all CSD registers is not known, the $f^{pushPull}$ clock rate is equal to the slow $f^{openDrain}$ clock rate. SEND_CSD (CMD9) allows the host to get the Card Specific Data (CSD register), e.g. ECC type, block length, card storage capacity, maximum clock rate etc..

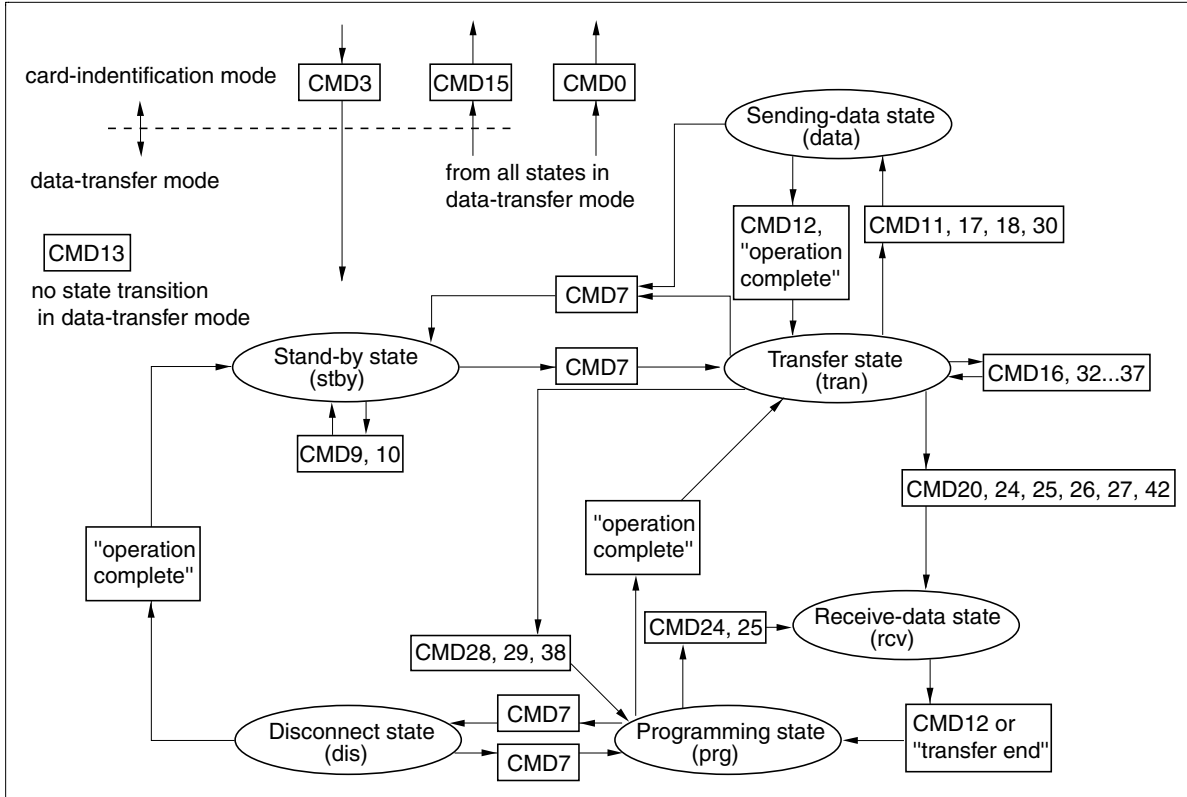

HB288064MM1 State Diagram (Data Transfer Mode)

The command SELECT_DESELECT_CARD (CMD7) is used to select one card and place it in the Transfer State. If a previously selected card is in the Transfer State its connection with the host is released and it will move back to the Stand-by State. Only one card can be, at any time, in the Transfer State. A selected card is responding the CMD7, the deselected one does not respond to this command. When CMD7 is sent including the reserved relative card address "0x0000", all cards transfer back to Stand-by State. This command is used to identify new cards without resetting other already acquired cards. Cards to which an RCA has already been assigned, do not respond to the identification command flow in this state. All the data communication in the Data Transfer Mode is consequently a point-to-point communication between the host and the selected card (using addressed commands). All addressed commands are acknowledged by a response on the CMD line. All read commands (data is sent from the card via data lines) can be interrupted at any time, by a stop command. The data transfer will terminate and the card will stop or start working on the next command. The DAT bus line signal level is high when no data is transmitted. A transmitted data block consists of a start bit (LOW), followed by a continuous data stream.

The data stream contains the net payload data (and error correction bits if an off-card ECC is used). The data stream ends with an end bit (HIGH). The data transmission is synchronous to the clock signal. The payload for block-oriented data transfer is preserved by a CRC check sum (refer to Chapter “Cyclic Redundancy Check (CRC)”).

- Stream read

There is a stream oriented data transfer controlled by READ_DAT_UNTIL_STOP (CMD11). This command instructs the card to send its payload, starting at a specified address, until the host sends a STOP_TRANSMISSION command (CMD12). The stop command has an execution delay due to the serial command transmission. The data transfer stops after the end bit of the stop command. If the end of the memory range is reached while sending data and no stop command has been sent yet by the host, the contents of the further transferred payload is undefined. The maximum clock frequency for stream read operation is given by the following formula:

$$\text{max. speed} = \min (\text{TRAN_SPEED}, (8 \cdot 2^{\text{READ_BL_LEN}} \cdot \text{NSAC}) / \text{TAAC}),$$

these parameters being defined in Chapter “Registers”. If the host attempts to use a higher frequency, the card may not be able to sustain data transfer. If this happens, the card will set the UNDERRUN error bit in the status register, abort the transmission and wait in the data state for a stop command.

- Block read

The basic unit of data transfer is a block whose maximum size is defined in the CSD (READ_BLK_LEN). READ_BLK_PARTIAL is set, thus smaller blocks whose starting and ending address are wholly contained within one physical block (as defined by READ_BLK_LEN) may also be transmitted. A CRC is appended to the end of each block ensuring data transfer integrity. READ_SINGLE_BLOCK (CMD17) starts a block read and after a complete transfer the card goes back to Transfer State. READ_MULTIPLE_BLOCK (CMD18) starts a transfer of several consecutive blocks. Blocks will be continuously transferred until a stop is issued.

- Stream write

Stream write (CMD20) starts the data transfer from the host to the card beginning from the starting address until the host issues a stop command. If partial blocks are allowed (if CSD parameter WRITE_BLK_PARTIAL is set) the data stream can start and stop at any address within the card address space, otherwise it shall start and stop only at block boundaries. Since the amount of data to be transferred is not determined in advance, CRC can not be used. If the end of the memory range is reached while sending data and no stop command has been sent by the host, all further transferred data is discarded. The maximum clock frequency for stream write operation is given by the following formula:

$$\text{max. speed} = \min (\text{TRAN_SPEED}, (8 \cdot 2^{\text{WRITE_BL_LEN}} \cdot \text{NSAC}) / (\text{TAAC} \cdot \text{R2W_FACTOR})),$$

these parameters being defined in Chapter “Registers”. If the host attempts to use a higher frequency, the card may not be able to process the data and will stop programming, set the OVERRUN error bit in the status register, and while ignoring all further data transfer, wait (in the Receive-data-State) for a stop command. The write operation shall also be aborted if the host tries to write over a write-protected area. In this case, however, the card shall set the WP_VIOLATION bit.

HB288064MM1

- Block write

Block write (CMD24 - 27) means that one or more blocks of data are transferred from the host to the card with a CRC appended to the end of each block by the host. A card supporting block write must always be able to accept a block of data defined by WRITE_BLK_LEN. If the CRC fails, the card will indicate the failure on the DAT line; the transferred data will be discarded and not written and all further transmitted blocks (in multiple block write mode) will be ignored. If the host uses partial blocks whose accumulated length is not block aligned and block misalignment is not allowed (CSD parameter WRITE_BLK_MISALIGN is not set), the card will detect the block misalignment error and abort programming before the beginning of the first misaligned block. The card will set the ADDRESS_ERROR error bit in the status register, and wait (in the Receive-data-State) for a stop command while ignoring all further data transfer. The write operation will also be aborted if the host tries to write over a write-protected area. In this case, however, the card will set the WP_VIOLATION bit. Programming of the CID and CSD register does not require a previous block length setting. The transferred data is also CRC protected. The HB288064MM1 write operation follows some special rules:

- Write to erased cells is done without automatic erase
 - Write to non-erased cells can be done by sending a previous erase command
 - Write to non-erased cells without a previous erase command enforces the card to erase before writing automatically (“rewrite”)
- Erase

It is desirable to erase as many sectors at a time as possible in order to enhance the data throughput. Identification of these sectors is accomplished with the TAG_* commands. Either an arbitrary set of sectors within a single erase group, or an arbitrary selection of erase groups may be erased at one time, but not both together. That is, the unit of measure for determining an erase is either a sector or an erase group, but if a sector, all selected sectors must lie within the same erase group. To facilitate selection, a first command with the starting address is followed by a second command with the final address, and all sectors within this range will be selected for erase. After a range is selected, an individual sector (or group) within that range can be removed using the UNTAG command. The host must adhere to the following command sequence; TAG_SECTOR_START, TAG_SECTOR_END, UNTAG_SECTOR (up to 16 untag sector commands can be sent for one erase cycle) and ERASE (or the same sequence for group tagging). The following exception conditions are detected by the card: An erase or tag/untag command is received out of sequence. The card will set the ERASE_SEQUENCE error bit in the status register and reset the whole sequence. An out of sequence command (except SEND_STATUS) is received. The card will set the ERASE_RESET status bit in the status register, reset the erase sequence and execute the last command. If the erase range includes write protected sectors, they will be left intact and only the non-protected sectors will be erased. The WP_ERASE_SKIP status bit in the status register will be set. The address field in the tag commands is a sector or a group address in byte units. The card will ignore all LSB's below the group or sector size. The number of untags commands (CMD34 and CMD37) which are used in a sequence is limited up to 16. As described above for block write, the card will indicate that an erase is in progress by holding DAT low. The actual erase time may be quite long, and the host may choose to deselect the card using CMD7.

- Write protect management

Card data may be protected against either erase or write. The entire card may be permanently write protected by the manufacturer or content provider by setting the permanent or temporary write protect bits in the CSD. Portions of the data may be protected (in units of WP_GRP_SIZE sectors as specified in the CSD), and the write protection may be changed by the application. The SET_WRITE_PROT command sets the write protection of the addressed write-protect group, and the CLR_WRITE_PROT command clears the write protection of the addressed write-protect group. The SEND_WRITE_PROT command is similar to a single block read command. The card shall send a data block containing 32 write protection bits (representing 32 write protect groups starting at the specified address) followed by 16 CRC bits. The address field in the write protect commands is a group address in byte units. The card will ignore all LSB's below the group size.

- Card lock/unlock operation

The password protection feature enables the host to lock a card while providing a password, which later will be used for unlocking the card. The password and its size are kept in a 128-bit PWD and 8-bit PWD_LEN registers, respectively. These registers are non-volatile so that a power cycle will not erase them. Locked cards respond to (and execute) all commands in the "basic" command class (class 0) and "lock card" command class. Thus the host is allowed to reset, initialize, select, query for status, etc., but not to access data on the card. If the password was previously set (the value of PWD_LEN is not '0') will be locked automatically after power on. Similar to the existing CSD and CID register write commands the lock/unlock command is available in "transfer state" only. This means that it does not include an address argument and the card has to be selected before using it. The card lock/unlock command has the structure and bus transaction type of a regular single block write command. The transferred data block includes all the required information of the command (password setting mode, PWD itself, card lock/unlock etc.). The following table describes the structure of the command data block.

Lock Card Data Structure

Byte#	Bit7	Bit6	Bit5	Bit4	Bit3	Bit2	Bit1	Bit0
0	Reserved				ERASE	LOCK_	CLR_	SET_
						UNLOCK	PWD	PWD
1	PWD_LEN							
2	Password data							
...								
PWD_LEN + 1								

- ERASE: 1 Defines Forced Erase Operation (all other bits shall be '0') and only the cmd byte is sent.
- LOCK/UNLOCK: 1 = Locks the card. 0 = Unlock the card (note that it is valid to set this bit together with SET_PWD but it is not allowed to set it together with CLR_PWD).
- CLR_PWD: 1 = Clears PWD.
- SET_PWD: 1 = Set new password to PWD
- PWD_LEN: Defines the following password length (in bytes).

HB288064MM1

- PWD: The password (new or currently used depending on the command).

The data block size shall be defined by the host before it sends the card lock/unlock command. This will allow different password sizes. The following paragraphs define the various lock/unlock command sequences:

- Setting the Password
 - Select a card (CMD7), if not previously selected already
 - Define the block length (CMD16), given by the 8bit card lock/unlock mode, the 8-bit password size (in bytes), and the number of bytes of the new password. In case that a password replacement is done, then the block size shall consider that both passwords, the old and the new one, are sent with the command.
 - Send Card Lock/Unlock command with the appropriate data block size on the data line including 16 bit CRC. The data block shall indicate the mode (SET_PWD), the length (PWD_LEN) and the password itself. In case that a password replacement is done, then the length value (PWD_LEN) shall include both passwords, the old and the new one, and the PWD field shall include the old password (currently used) followed by the new password.
 - In case that the sent old password is not correct (not equal in size and content) then LOCK_UNLOCK_FAILED error bit will be set in the status register and the old password password and its size will be saved in the PWD and PWD_LEN fields, respectively.

Note that the password length register (PWD_LEN) indicates if a password is currently set. When it equals '0' there is no password set. If the value of PWD_LEN is not equal to zero the card will lock itself after power up. It is possible to lock the card immediately in the current power session by set-ting the LOCK/UNLOCK bit (while setting the password) or sending additional command for card lock.

- Reset the Password:
 - Select a card (CMD7), if not previously selected already
 - Define the block length (CMD16), given by the 8 bit card lock/unlock mode, the 8 bit password size (in bytes), and the number of bytes of the currently used password.
 - Send the card lock/unlock command with the appropriate data block size on the data line including 16 bit CRC. The data block shall indicate the mode CLR_PWD, the length (PWD_LEN) and the password (PWD) itself (LOCK/UNLOCK bit is don't care). If the PWD and PWD_LEN content match the sent password and its size, then the content of the PWD register is cleared and PWD_LEN is set to 0. If the password is not correct then the LOCK_UNLOCK_FAILED error bit will be set in the status register.
- Locking a card:
 - Select a card (CMD7), if not previously selected already
 - Define the block length (CMD16), given by the 8 bit card lock/unlock mode, the 8 bit password size (in bytes), and the number of bytes of the currently used password.

—Send the card lock/unlock command with the appropriate data block size on the data line including 16 bit CRC. The data block shall indicate the mode LOCK, the length (PWD_LEN) and the password (PWD) itself.

If the PWD content equals to the sent password then the card will be locked and the card-locked status bit will be set in the status register. If the password is not correct then LOCK_UNLOCK_FAILED error bit will be set in the status register. Note that it is possible to set the password and to lock the card in the same sequence. In such case the host shall perform all the required steps for setting the password (as described above) including the bit LOCK set while the new password command is sent. If the password was previously set (PWD_LEN is not '0'), then the card will be locked automatically after power on reset. An attempt to lock a locked card or to lock a card that does not have a password will fail and the LOCK_UNLOCK_FAILED error bit will be set in the status register.

- Unlocking the card:

—Select a card (CMD7), if not previously selected already.

—Define the block length (CMD16), given by the 8 bit card lock/unlock mode, the 8 bit password size (in bytes), and the number of bytes of the currently used password.

—Send the card lock/unlock command with the appropriate data block size on the data line including 16 bit CRC. The data block shall indicate the mode UNLOCK, the length (PWD_LEN) and the password (PWD) itself.

If the PWD content equals to the sent password then the card will be unlocked and the card-locked status bit will be cleared in the status register. If the password is not correct then the LOCK_UNLOCK_FAILED error bit will be set in the status register. Note that the unlocking is done only for the current power session. As long as the PWD is not cleared the card will be locked automatically on the next power up. The only way to unlock the card is by clearing the password. An attempt to unlock an unlocked card will fail and LOCK_UNLOCK_FAILED error bit will be set in the status register.

- Forcing Erase:

In case that the user forgot the password (the PWD content) it is possible to erase all the card data content along with the PWD content. This operation is called Forced Erase.

—Select a card (CMD7), if not previously selected already.

—Define the block length (CMD16) to 1 byte (8bit card lock/unlock command). Send the card lock/unlock command with the appropriate data block of one byte on the data line including 16 bit CRC. The data block shall indicate the mode ERASE (the ERASE bit shall be the only bit set).

If the ERASE bit is not the only bit in the data field then the LOCK_UNLOCK_FAILED error bit will be set in the status register and the erase request is rejected. If the command was accepted then ALL THE CARD CONTENT WILL BE ERASED including the PWD and PWD_LEN register content and the locked card will get unlocked. An attempt to force erase on an unlocked card will fail and LOCK_UNLOCK_FAILED error bit will be set in the status register.

HB288064MM1

- State transition summary

Table “Card State Transition Table” defines the card state transitions as a function of received command

Card State Transition Table

Command	Current state										
	idle	ready	ident	stby	tran	data	rcv	prg	dis	ina	
CRC fail	—*1	—	—	—	—	—	—	—	—	—	—
Commands out of the supported class(es)	—	—	—	—	—	—	—	—	—	—	—
Class0 CMD0	idle	idle	idle	idle	idle	idle	idle	idle	idle	idle	—
CMD1, card V _{cc} range compatible	ready	—	—	—	—	—	—	—	—	—	—
CMD1, card is busy	idle	—	—	—	—	—	—	—	—	—	—
CMD1, card V _{cc} range not compatible	ina	—	—	—	—	—	—	—	—	—	—
CMD2, card wins bus	—	ident	—	—	—	—	—	—	—	—	—
CMD2, card loses bus	—	ready	—	—	—	—	—	—	—	—	—
CMD3	—	—	stby	—	—	—	—	—	—	—	—
CMD4	—	—	—	stby	—	—	—	—	—	—	—
CMD7, card is addressed	—	—	—	tran	×*2	×	×	×	prg	—	—
CMD7, card is not addressed	—	—	—	—	stby	stby	—	dis	—	—	—
CMD9	—	—	—	stby	—	—	—	—	—	—	—
CMD10	—	—	—	stby	—	—	—	—	—	—	—
CMD12	—	—	—	—	×	tran	prg	×	×	—	—
CMD13	—	—	—	stby	tran	data	rcv	prg	dis	—	—
CMD15	—	—	—	ina	ina	ina	ina	ina	ina	ina	—
Class1 CMD11	—	—	—	—	data	—	—	—	—	—	—
Class2 CMD16	—	—	—	—	tran	×	×	×	—	—	—
CMD17	—	—	—	—	data	×	×	×	—	—	—
CMD18	—	—	—	—	data	×	×	×	—	—	—
Class3 CMD20	—	—	—	—	rcv	—	—	—	—	—	—

Command	Current state										
	idle	ready	ident	stby	tran	data	rcv	prg	dis	ina	
Class4	CMD24	—	—	—	—	rcv	×	×	rcv	—	—
	CMD25	—	—	—	—	rcv	×	×	rcv	—	—
	CMD26	—	—	—	—	rcv	×	×	×	—	—
	CMD27	—	—	—	—	rcv	×	×	×	—	—
Class5	CMD32	—	—	—	—	tran	×	×	×	—	—
	CMD33	—	—	—	—	tran	×	×	×	—	—
	CMD34	—	—	—	—	tran	×	×	×	—	—
	CMD35	—	—	—	—	tran	×	×	×	—	—
	CMD36	—	—	—	—	tran	×	×	×	—	—
	CMD37	—	—	—	—	tran	×	×	×	—	—
	CMD38	—	—	—	—	prg	×	×	×	—	—
Class6	CMD28	—	—	—	—	prg	×	×	×	—	—
	CMD29	—	—	—	—	prg	×	×	×	—	—
	CMD30	—	—	—	—	data	×	×	×	—	—
Class7	CMD42	—	—	—	—	rcv	—	—	—	—	—

- Notes: 1. “—” means command is ignored, no state change and no response.
 2. “×” means “illegal command”, no state change and bit 22 (ILLEGAL_COMMAND) of the status word de-fined in Chapter “Status” is set in the corresponding response.

HB288064MM1

Responses

All responses are sent via command line (CMD), all data starts with the MSB.

Format R1 (response command): response length 48 bit.

0	0	bit5...bit0	bit31...bit0	bit6...bit0	1
start bit	card	command	status	CRC	end bit

The contents of the status field are described in Chapter “Status”

Format R1b (response command with busy signal):

R1b is identical to R1 with an optional busy signal transmitted on the data line. The card may become busy after receiving these commands based on its state prior to the command reception.

Format R2 (CID, CSD register): response length 136 bits.

Note: Bit 127 down to bit 1 of CID and CSD are transferred, the reserved bit [0] is replaced by the end bit.

0	0	bit5...bit0	bit127...bit1	1
start bit	card	reserved	CID or CSD register including internal CRC	end bit

CID register is sent as a response to commands CMD2 and CMD10.

CSD register is sent as a response to the CMD9.

Format R3 (OCR): response length 48 bits.

0	0	bit5...bit0	bit31...bit0	bit6...bit0	1
start bit	card	reserved	OCR field	reserved	end bit

The OCR is sent as a response to the CMD1 to signalize the supported voltage range. The HB288064MM1 supports the range from 2.7 V to 3.6 V. Respectively the value of all bits of the OCR field of the HB288064MM1 is set to 0x80FF8000. So the R3 frame of the HB288064MM1 contains the value 0x3F80FF8000FF if the card is ready and 0x3F00FF8000FF if the card is busy.

Status

The response format R1 contains a 32-bit field with the name card status. This field is intended to transmit status information which is stored in a local status register of each card to the host. The following table defines the status register structure. The Type and Clear-Condition fields in the table are coded as follows:

- Type:
 - E: Error bit.
 - S: Status bit.
 - R: Detected and set for the actual command response.
 - X: Detected and set during command execution. The host must poll the card by sending status command in order to read these bits.

- Clear Condition:
 - A: According to the card state.
 - B: Always related to the previous command. Reception of a valid command will clear it (with a delay of one command).
 - C: Clear by read.

HB288064MM1

Status

Bits	Identifier	Type	Value	Description	Clear condition
31	OUT_OF_RANGE	E R	'0'= no error '1'= error	The commands argument was out of allowed range for this card.	C
30	ADDRESS_ERROR	E R X	'0'= no error '1'= error	A misaligned address, which did not match the block length was used in the command.	C
29	BLOCK_LEN_ERROR	E R	'0'= no error '1'= error	The transferred block length is not allowed for this card or the number of transferred bytes does not match the block length	C
28	ERASE_SEQ_ERROR	E R	'0'= no error '1'= error	An error in the sequence of erase commands occurred.	C
27	ERASE_PARAM	E X	'0'= no error '1'= error	An invalid selection, sectors or groups, for erase.	C
26	WP_VIOLATION	E R X	'0'= not protected '1'= protected	The command tried to write a write protected block.	C
25	CARD_IS_LOCKED	S X	'0'= card unlocked '1'= card locked	When set, signals that the card is locked by the host.	A
24	LOCK_UNLOCK_FAILED	E R X	'0'= no error '1'= error	Set when a sequence or password error has been detected in lock/unlock card command or it there was an attempt to access a locked card.	C
23	COM_CRC_ERROR	E R	'0'= no error '1'= error	The CRC check of the previous command failed.	B
22	ILLEGAL_COMMAND	E R	'0'= no error '1'= error	Command not legal for the current state	B
21	CARD_ECC_FAILED	E X	'0'= success '1'= failure	Card internal ECC was applied but the correction of data is failed.	C
20	CC_ERROR	E R X	'0'= no error '1'= error	Internal card controller error	C
19	ERROR	E R X	'0'= no error '1'= error	A general or an unknown error occurred during the operation.	C
18	UNDERRUN	E X	'0'= no error '1'= error	The card could not sustain data transfer in stream read mode.	C
17	OVERRUN	E X	'0'= no error '1'= error	The card could not sustain data programming in stream write mode.	C

HB288064MM1

Bits	Identifier	Type	Value	Description	Clear Condition
16	CID_OVERWRITE/ CSD_OVERWRITE	E R X	'0'= no error '1'= error	can be either one of the following errors: <ul style="list-style-type: none"> • The CID register is already written and can not be overwritten. • The read only section of the CSD does not match the card content. • An attempt to reversecopy (set as original) or permanent WP (unprotect) bits was done. 	C
15	WP_ERASE_SKIP	S X	'0'= not protected '1'= protected	Only partial address space was erased due to existing WP blocks.	C
14	CARD_ECC_ DISABLED	S X	'0'= enabled '1'= disabled	The command has been executed without using the internal ECC.	A
13	ERASE_RESET	S R	'0'= cleared '1'= set	An erase sequence was cleared before executing because an out of erase sequence command was received	C
12:9	CURRENT_STATE	S X	0 = idle 1 = ready 2 = ident 3 = stby 4 = tran 5 = data 6 = rcv 7 = prg 8 = dis 9-15 = reserved	Current state of the card.	B
8	BUFFER_EMPTY	S X	'0'= not empty '1'= empty	corresponds to buffer empty signalling on the bus	A
7:6	reserved		Permanently 0		
5	APP_CMD	S R	'0'= disabled '1'= enabled	The card will expect ACMD or indication that the command has been interpreted as ACMD.	C
4	reserved		Permanently 0		
3:2	reserved for application specific commands				
1:0	reserved for manufacturer test mode				

HB288064MM1

Command Response Timings

All timing diagrams use the following schematics and abbreviations:

S: Start bit (= 0)

T: Transmitter bit (Host = 1, Card = 0)

P: One-cycle pull-up (= 1)

E: End bit (= 1)

Z: high impedance state (-> = 1)

D: Data bits

*: repeater

CRC: Cyclic redundancy check bits (7 bits)

The difference between the P-bit and Z-bit is that a P-bit is actively driven to HIGH by the card respectively host output driver, while the Z-bit is driven to (respectively kept) HIGH by the pull-up resistors R_{CMD} respectively R_{DAT} . Actively driven P-bits are less sensitive to noise superposition. For the timing of the HB288064MM1, the following values are defined:

Timing Values

Symbol	Value [clock cycles]		Description
	Min	Max	
N_{CR}	2	64	Number of cycles between command and response
N_{ID}	5	5	Number of cycles between card identification or card operation conditions command and the corresponding response
N_{AC}	2^{*1}	TAAC + NSAC ^{*2}	Number of cycles between a command and the start of a related data block
N_{RC}	8	—	Number of cycles between the last response and a new command
N_{CC}	8	—	Number of cycles between two commands, if no response will be sent after the first command (e.g. broadcast)
N_{WR}	2	—	Number of cycles between a write command and the start of a related data block

Notes: 1. Refer to Chapter "Electrical Characteristics" for more details about the access time.
2. Refer to Chapter "Time-out Condition".

The host command and the card response are clocked out with the rising edge of the host clock. The delay between host command and card response is N_{CR} clock cycles. The following timing diagram is relevant for host command CMD3:

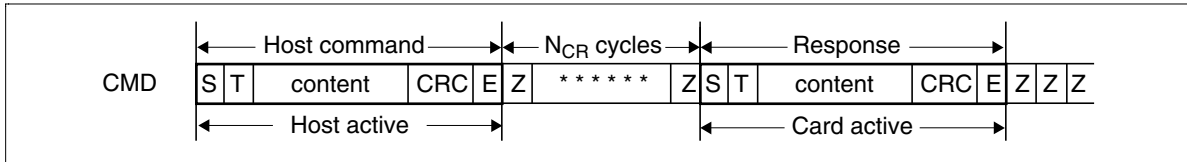

Command Response Timing (Identification Mode)

There is just one Z bit period followed by P bits pushed up by the responding card. The following timing diagram is relevant for all host commands followed by a response, except CMD1, CMD2 and CMD3:

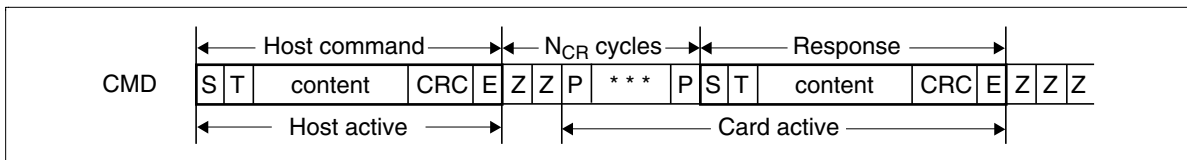

Command Response Timing (Data Transfer Mode)

- Card identification and card operation conditions timing

The card identification (CMD2) and card operation condition (CMD1) timing are processed in the open-drain mode. The card response to the host command starts after exactly N_{ID} clock cycles.

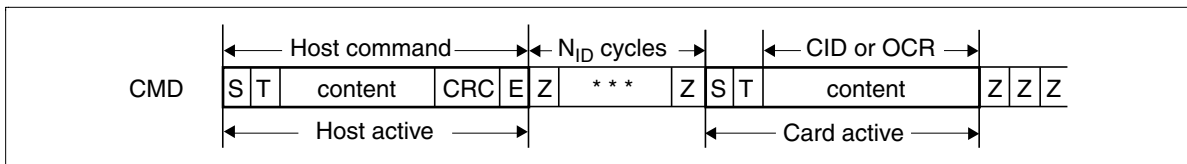

Identification Timing (Card Identification Mode)

- Last card response - next host command timing

After receiving the last card response, the host can start the next command transmission after at least N_{RC} clock cycles. This timing is relevant for any host command.

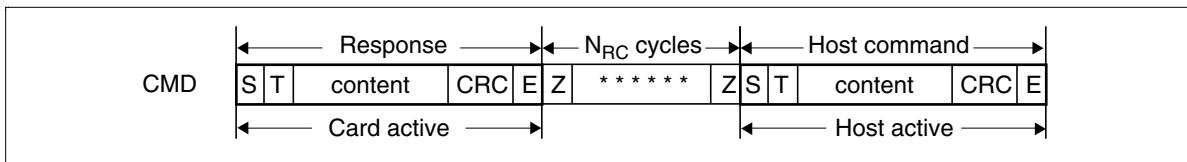

Timing Response End to Next CMD Start (Data Transfer Mode)

HB288064MM1

- Last host command - next host command timing diagram

After the last command, which does not force a response, has been sent, the host can continue sending the next command after at least N_{CC} clock periods.

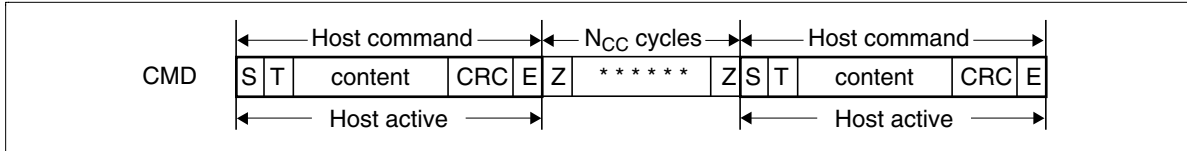

Timing CMD_n End to CMD_{n+1} Start (All Modes)

In the case the CMD_n command was a last identification command (no more response sent by a card), then the next CMD_{n+1} command is allowed to follow after at least $N_{CC} + 136$ (the length of the R2 response) clock periods.

- Data access timing

Data transmission starts with the access time delay t_{AC} (which corresponds to N_{AC}), beginning from the end bit of the data address command. The data transfer stops automatically in case of a data block transfer or by a transfer stop command.

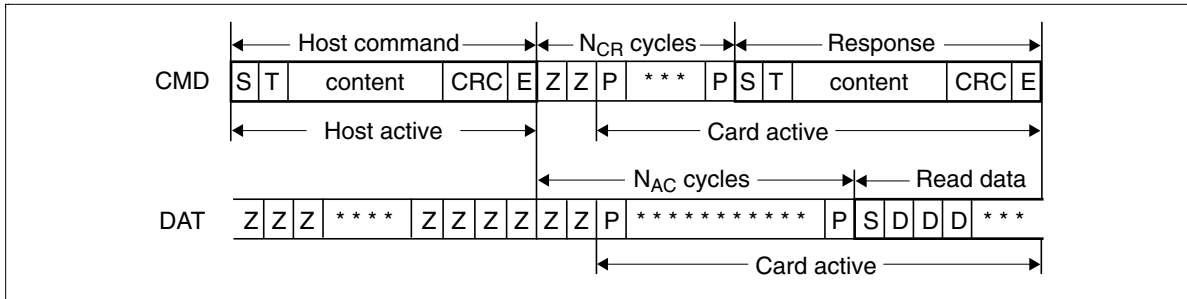

Data Read Timing (Data Transfer Mode)

- Data transfer stop command timing

The card data transmission can be stopped using the stop command. The data transmission stops immediately with the end bit of the stop command.

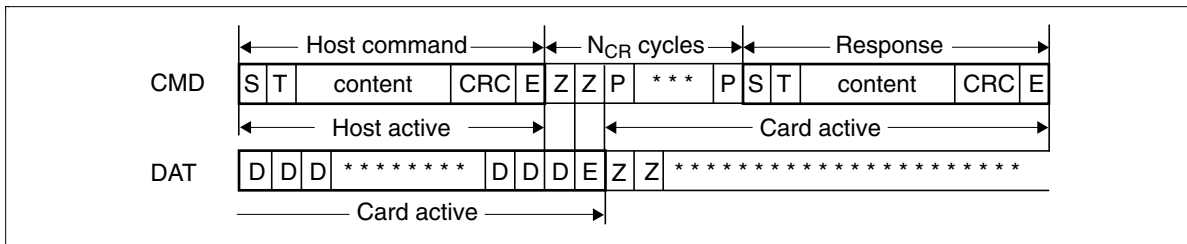

Timing of Stop Command (CMD12, Data Transfer Mode)

- Stream read

The data transfer starts N_{AC} clock cycles after the end bit of the host command. The bus transaction is identical to that of a read block command (refer to Figure “Data Read Timing”). As the data transfer is not block-oriented, the data stream does not include the CRC checksum. Consequently the host can not check for data validity. The data stream is terminated by a stop command. The corresponding bus transaction is identical to the stop command for the multiple read block (refer to Figure “Timing of Stop Command”).

- Single or multiple block write

The host selects one card for data write operation by CMD7. The host sets the valid block length for block-oriented data transfer by CMD16. The host transfers the data with CMD24. The address of the data block is determined by the argument of this command. This command is responded by the card on the CMD line as usual. The data transfer from the host starts N_{WR} clock cycles after the card response was received. The write data have CRC check bits to allow the card to check the transferred data for transmission errors. The card sends the CRC check information as a CRC status to the host (on the data line). The CRC status contains the information if the write data transfer was non-erroneous (the CRC check did not fail) or not. In the case of transmission error the card sends a negative CRC status (“101” bin) which forces the host to retransmit the data. In the case of non-erroneous transmission the card sends a positive CRC status (“010” bin) and starts the data programming procedure.

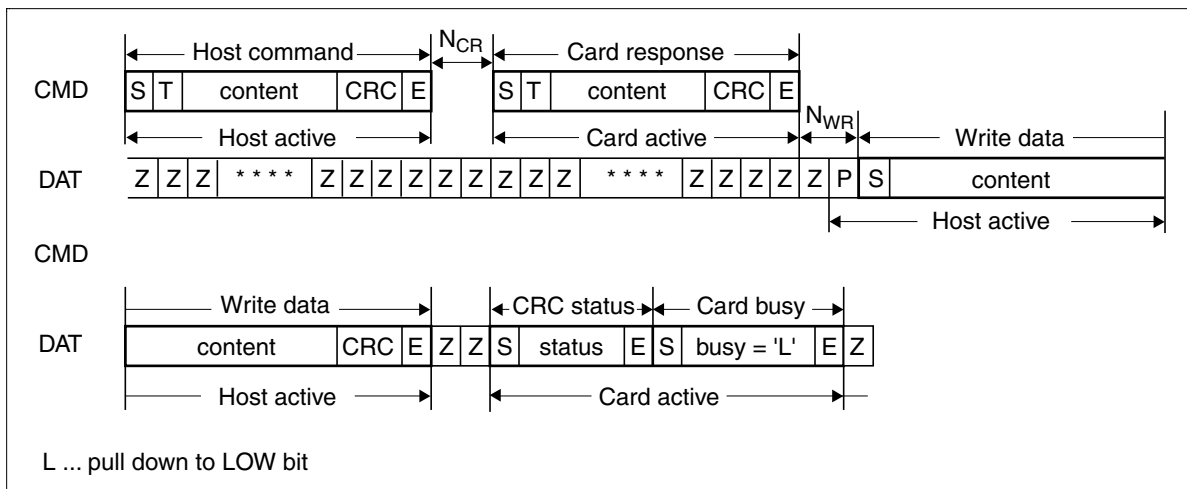

Timing of The Block Write Command

If the card does not have any more free data receive buffer, the card indicates it by pulling down the data line to LOW. The card stops pulling down the data line as soon as at least one receive buffer for the defined data transfer block length becomes free. This signalling does not give any information about the data write status. This information has to be polled by the status polling command.

HB288064MM1

- Stream write

The data transfer starts N_{WR} clock cycles after the card response to the sequential write command was received. The bus transaction is identical to that of a write block command (see Figure “Timing of The Block Write Command”). As the data transfer is not block-oriented, the data stream does not include the CRC checksum. Consequently the host can not receive any CRC status information from the card. The data stream is terminated by a stop command. The bus transaction is identical to the write block option when a data block is interrupted by the stop command (see Figure “Stop Transmission During Data Transfer From The Host”).

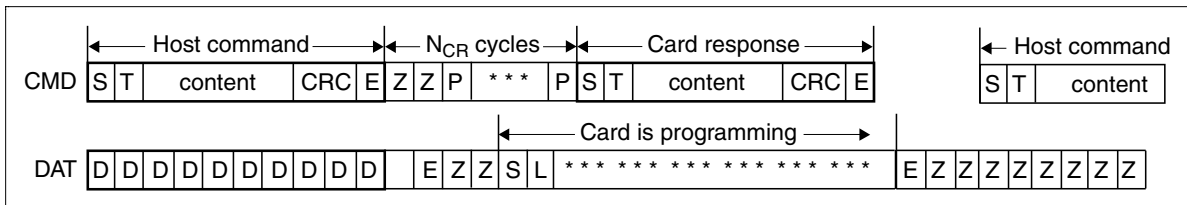

Stop Transmission During Data Transfer From The Host

- Erase block timing

The host must first tag the sector to erase. The tagged sector(s) are erased in parallel by using the CMD32-CMD38. The card busy signalling is also used for the indication of the card erase procedure duration. In this case the end of the card busy signalling also does mean that the erase of all tagged sectors has been finished. The host can (also) request the card to send the actual card state using the CMD13.

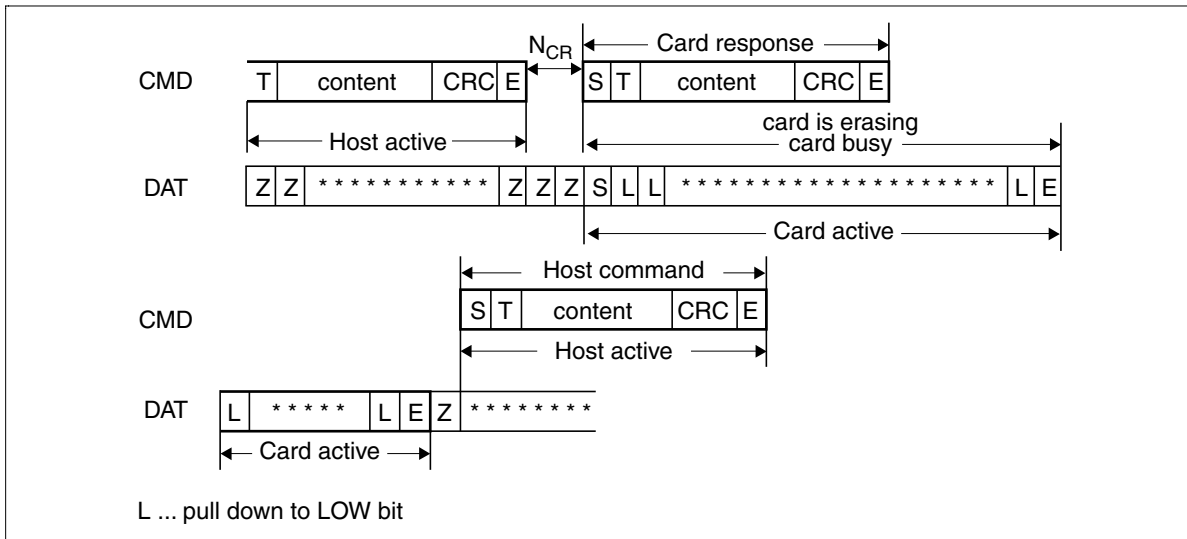

Timing of Erase Operation

Reset

GO_IDLE_STATE (CMD0) is the software reset command, which sets the HB288064MM1 into the Idle State independently of the current state. In the Inactive State the HB288064MM1 is not affected by this command. After power-on the HB288064MM1 is always in the Idle State. After power-on or command GO_IDLE_STATE (CMD0) all output bus drivers of the HB288064MM1 is in a high-impedance state and the card will be initialized with a default relative card address (“0x0001”). The host runs the bus at the identification clock rate f_{OD} generated by a push-pull driver stage (refer to also Chapter “Power on” for more details).

SPI Communication

The SPI mode consists of a secondary communication protocol. This mode is a subset of the MultiMediaCard protocol, designed to communicate with a SPI channel, commonly found in Motorola's (and lately a few other vendors') microcontrollers. The interface is selected during the first reset command after power up (CMD0) and cannot be changed once the part is powered on. The SPI standard defines the physical link only, and not the complete data transfer protocol. The MultiMediaCard SPI implementation uses a subset of the MultiMediaCard protocol and command set. It is intended to be used by systems which require a small number of card (typically one) and have lower data transfer rates (compared to MultiMediaCard protocol based systems). From the application point of view, the advantage of the SPI mode is the capability of using an off-the-shelf host, hence reducing the design-in effort to minimum. The disadvantage is the loss of performance of the SPI system versus MultiMediaCard (lower data transfer rate, fewer cards, hardware CS per card etc.). While the MultiMediaCard channel is based on command and data bitstreams which are initiated by a start bit and terminated by a stop bit, the SPI channel is byte oriented. Every command or data block is built of 8-bit bytes and is byte aligned to the CS signal (i.e. the length is a multiple of 8 clock cycles). Similar to the MultiMediaCard protocol, the SPI messages consist of command, response and data-block tokens (refer to Chapter "Commands" and Chapter "Responses" for a detailed description). All communication between host and cards is controlled by the host (master). The host starts every bus transaction by asserting the CS signal low. The response behavior in the SPI mode differs from the MultiMediaCard mode in the following three aspects:

- The selected card always responds to the command.
- An additional (8 bit) response structure is used
- When the card encounters a data retrieval problem, it will respond with an error response (which replaces the expected data block) rather than by a time-out as in the MultiMediaCard mode.

Only single block read write operations are supported in SPI mode. In addition to the command response, every data block sent to the card during write operations will be responded with a special data response token. A data block may be as big as one card sector and as small as a single byte. Partial block read/write operations are enabled by card options specified in the CSD register.

Mode Selection

The MultiMediaCard wakes up in the MultiMediaCard mode. It will enter SPI mode if the CS signal is asserted (negative) during the reception of the reset command (CMD0). If the card recognizes that the MultiMediaCard mode is required it will not respond to the command and remain in the MultiMediaCard mode. If SPI mode is required the card will switch to SPI and respond with the SPI mode R1 response. The only way to return to the MultiMediaCard mode is by entering the power cycle. In SPI mode the MultiMediaCard protocol state machine is not observed. All the MultiMediaCard commands supported in SPI mode are always available.

Bus Transfer Protection

Every MultiMediaCard token transferred on the bus is protected by CRC bits. In SPI mode, the MultiMediaCard offers a non protected mode which enables systems built with reliable data links to exclude the hardware or firmware required for implementing the CRC generation and verification functions. In the non-protected mode the CRC bits of the command, response and data tokens are still required in the tokens. However, they are defined as “don’t care” for the transmitter and ignored by the receiver. The SPI interface is initialized in the non protected mode. The host can turn this option on and off using the CRC_ON_OFF command (CMD59).

Data Read Overview

The SPI mode supports single block read operations only (CMD17 in the MultiMediaCard protocol). Upon reception of a valid read command the card will respond with a response token followed by a data token of the length defined in a previous SET_BLOCKLEN (CMD16) command (refer to Figure “Read Operation”).

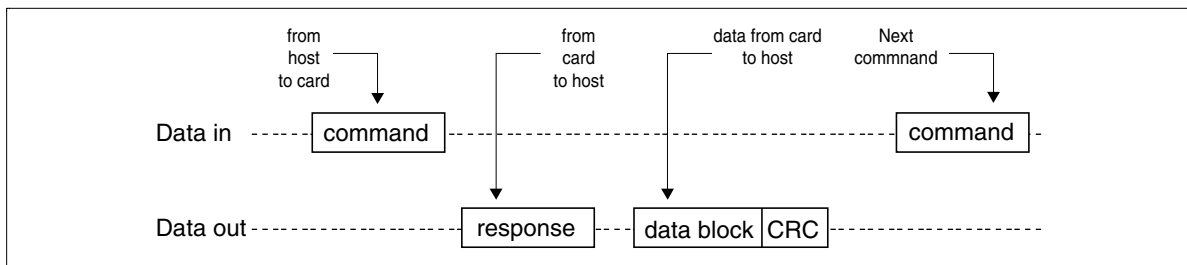

Read Operation

A valid data block is suffixed with a 16 bit CRC generated by the standard CCITT polynomial

$$x^{16} + x^{12} + x^5 + 1.$$

The maximum block length is given by READ_BL_LEN, defined in the CSD. If partial blocks are allowed (i.e. the CSD parameter READ_BL_PARTIAL equals 1), the block length can be any number between 1 and the maximum block size. Otherwise, the only valid block length for data read is given by READ_BL_LEN. The start address can be any byte address in the valid address range of the card. Every block, however, must be contained in a single physical card sector. In case of a data retrieval error, the card will not transmit any data. Instead, a special data error token will be sent to the host. Figure “Read Operation-Data Error” shows a data read operation which terminated with an error token rather than a data block.

HB288064MM1

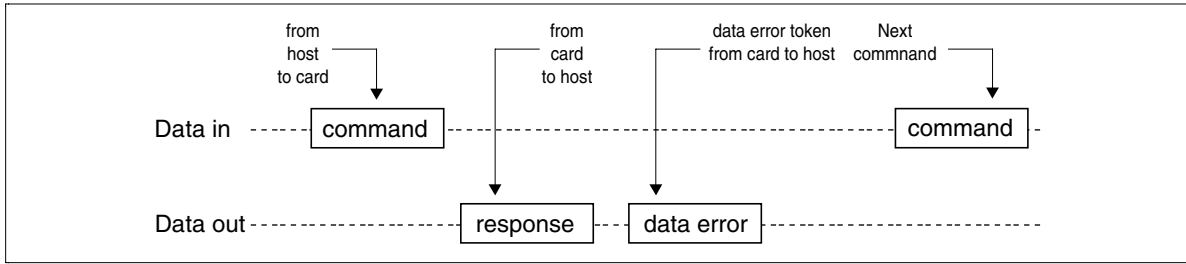

Read Operation-Data Error

Data Write Overview

As for the read operation, while in SPI mode the MultiMediaCard supports single block write commands only. Upon reception of a valid write command (CMD24 in the MultiMediaCard protocol), the card will respond with a response token and will wait for a data block to be sent from the host. CRC suffix, block length and start address restrictions are (with the exception of the CSD parameter WRITE_BL_PARTIAL controlling the partial block write option) identical to the read operation (refer to Figure “Write Operation”).

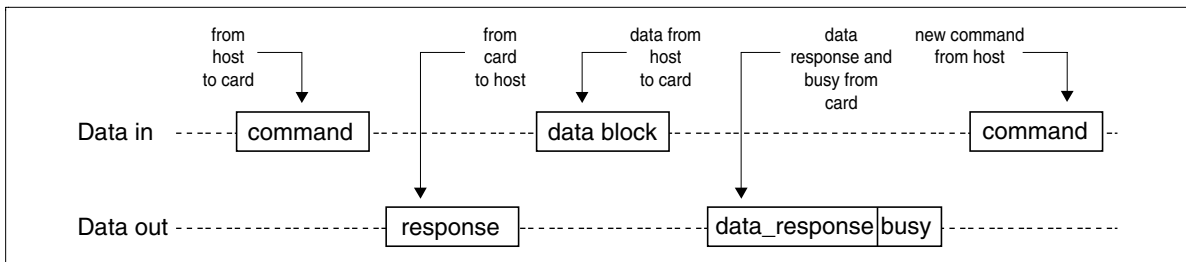

Write Operation

After a data block has been received, the card will respond with a data-response token. If the data block has been received without errors, it will be programmed. As long as the card is busy programming, a continuous stream of busy tokens will be sent to the host (effectively holding the DataOut line low). Once the programming operation is completed, the host must check the results of the programming using the SEND_STATUS command (CMD13). Some errors (e.g. address out of range, write protect violation etc.) are detected during programming only. The only validation check performed on the data block and communicated to the host via the data-response token is the CRC. While the card is busy, resetting the CS signal will not terminate the programming process. The card will release the DataOut line (tri-state) and continue with programming. If the card is reselected before the programming is finished, the DataOut line will be forced back to low and all commands will be rejected. Resetting a card (using CMD0) will terminate any pending or active programming operation. This may destroy the data formats on the card. It is in the responsibility of the host to prevent it.

Erase and Write Protect Management

The erase and write protect management procedures in the SPI mode are identical to those of the MultiMediaCard mode. While the card is erasing or changing the write protection bits of the predefined sector list, it will be in a busy state and hold the DataOut line low. Figure “No Data Operations” illustrates a ‘no data’ bus transaction with and without busy signalling.

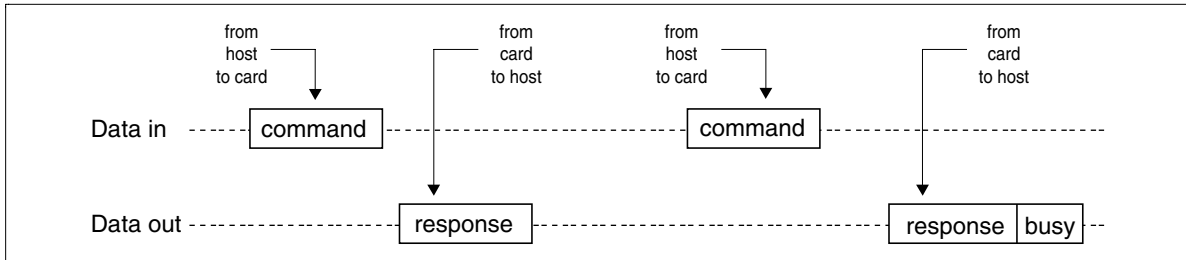

‘No Data’ Operations

Reading CID/CSD Registers

Unlike the MultiMediaCard protocol (where the register contents are sent as a command response), reading the contents of the CSD and CID registers in SPI mode is a simple read-block transaction. The card will respond with a standard response token (refer to Figure “Read Operation”) followed by a data block of 16 bytes suffixed with a 16 bit CRC. The data timeout for the CSD command cannot be set to the card TAAC since this value is stored in the CSD. Therefore the standard response timeout value (N_{CR}) is used for read latency of the CSD register.

Reset Sequence

The MultiMediaCard requires a defined reset sequence. After power on reset or CMD0 (software reset) the card enters an idle state. At this state the only legal host command is CMD1 (SEND_OP_COND) and CMD58 (READ_OCR). In SPI mode, as opposed to MultiMediaCard mode, CMD1 has no operands and does not return the contents of the OCR register. Instead, the host may use CMD58 (available in SPI mode only) to read the OCR register. Furthermore, it is in the responsibility of the host to refrain from accessing cards that do not support its voltage range. The usage of CMD58 is not restricted to the initializing phase only, but can be issued at any time. The host must poll the card (by repeatedly sending CMD1) until the ‘in-idle-state’ bit in the card response indicates (by being set to 0) that the card completed its initialization processes and is ready for the next command. The host must poll the card (by repeatedly sending CMD1) until the ‘in-idle-state’ bit in the card response indicates (by being set to 0) that the card completed its initialization processes and is ready for the next command.

HB288064MM1

Error Conditions

Unlike the MultiMediaCard protocol, in the SPI mode the card will always respond to a command. The response indicates acceptance or rejection of the command. A command may be rejected if it is not supported (illegal opcode), if the CRC check failed, if it contained an illegal operand, or if it was out of sequence during an erase sequence.

Memory Array Partitioning

Same as for MultiMediaCard mode.

Card Lock/Unlock

Usage of card lock and unlock commands in SPI mode is identical to MultiMediaCard mode. In both cases the command response is of type R1b. After the busy signal clears, the host should obtain the result of the operation by issuing a GET_STATUS command. Please refer to Chapter “Card lock/unlock operation” for details.

Commands

All the MultiMediaCard commands are 6 bytes long. The command transmission always starts with the left bit of the bitstring corresponding to the command codeword. All commands are protected by a CRC. The commands and arguments are listed in Table

Bit position	[47]	[46]	[45:40]	[39:8]	[7:1]	[0]
Width (bits)	1	1	6	32	7	1
Value	'0'	'1'	×	×	×	'1'
Description	start bit	transmission bit	command index	argument	CRC7	end bit

The following table provides a detailed description of the SPI bus commands. The responses are defined in Chapter “Responses”. The Table “Commands and Arguments” lists all MultiMediaCard commands. A “yes” in the SPI mode column indicates that the command is supported in SPI mode. With these restrictions, the command class description in the CSD is still valid. If a command does not require an argument, the value of this field should be set to zero. The reserved commands are reserved in MultiMediaCard mode as well. The binary code of a command is defined by the mnemonic symbol. As an example, the content of the command index field is (binary) ‘000000’ for CMD0 and ‘100111’ for CMD39.

Commands and Arguments

CMD index	SPI mode	Argument	Resp	Abbreviation	Command description
CMD0	Yes	None	R1	GO_IDLE_STATE	resets the MultiMediaCard
CMD1	Yes	None	R1	SEND_OP_COND	Activates the card's initialization process.
CMD2	No				
CMD3	No				
CMD4	No				
CMD5	reversed				
CMD6	reversed				
CMD7	No				
CMD8	reversed				
CMD9	Yes	None	R1	SEND_CSD	asks the selected card to send its card-specific data (CSD)
CMD10	Yes	None	R1	SEND_CID	asks the selected card to send its card identification (CID)
CMD11	No				
CMD12	No				
CMD13	Yes	None	R2	SEND_STATUS	asks the selected card to send its status register.
CMD14	reversed				
CMD15	No				
CMD16	Yes	[31:0] block length	R1	SET_BLOCKLEN	selects a block length (in bytes) for all following block commands (read and write). ^{*1}
CMD17	Yes	[31:0] data address	R1	READ_SINGLE_BLOCK	reads a block of the size selected by the SET_BLOCKLEN command. ^{*2}
CMD18	No				
CMD19	reversed				
CMD20	No				
CMD21... CMD23	reversed				

HB288064MM1

CMD index	SPI mode	Argument	Resp	Abbreviation	Command description
CMD24	Yes	[31:0] data address	R1b* ³	WRITE_BLOCK	writes a block of the size selected by the SET_BLOCKLEN command.* ⁴
CMD25	No				
CMD26	No				
CMD27	Yes	None	R1b	PROGRAM_CSD	programming of the programmable bits of the CSD.
CMD28	Yes	[31:0] data address	R1b	SET_WRITE_PROT	if the card has write protection features, this command sets the write protection bit of the addressed group. The properties of write protection are coded in the card specific data (WP_GRP_SIZE).
CMD29	Yes	[31:0] data address	R1b	CLR_WRITE_PROT	if the card has write protection features, this command clears the write protection bit of the addressed group.
CMD30	Yes	[31:0] write protect data address	R1	SEND_WRITE_PROT	if the card has write protection features, this command asks the card to send the status of the write protection bits.* ⁵
CMD31	reversed				
CMD32	Yes	[31:0] data address	R1	TAG_SECTOR_START	sets the address of the first sector of the erase group.
CMD33	Yes	[31:0] data address	R1	TAG_SECTOR_END	sets the address of the last sector in a continuous range within the selected erase group, or the address of a single sector to be selected for erase.
CMD34	Yes	[31:0] data address	R1	UNTAG_SECTOR	removes one previously selected sector from the erase selection.
CMD35	Yes	[31:0] data address	R1	TAG_ERASE_GROUP_START	sets the address of the first erase group within a range to be selected for erase
CMD36	Yes	[31:0] data address	R1	TAG_ERASE_GROUP_END	sets the address of the last erase group within a continuous range to be selected for erase
CMD37	Yes	[31:0] data address	R1	UNTAG_ERASE_GROUP	removes one previously selected erase group from the erase selection
CMD38	Yes	[31:0] stuff bits	R1b	ERASE	erases all previously selected sectors
CMD39	No				
CMD40	No				

HITACHI

HB288064MM1

CMD index	SPI mode	Argument	Resp	Abbreviation	Command description
CMD41	reserved				
CMD42	Yes	[31:0] stuff bits	R1b	LOCK/UNLOCK	Used to set/reset the password or lock/unlock the card. The structure of the data block is described in chapter "Card lock/unlock operation". The size of the Data Block is defined by the SET_BLOCK_LEN command.
CMD43...	reserved				
CMD57					
CMD58	Yes	None	R3	READ_OCR	Reads the OCR register of a card.
CMD59	Yes	[31:1] stuff bits [0:0] CRC option	R1	CRC_ON_OFF	Turns the CRC option on or off. A '1' in the CRC option bit will turn the option on, a '0' will turn it off
CMD60	No				

- Notes:
1. The default block length is as specified in the CSD.
 2. The data transferred must not cross a physical block boundary unless READ_BLK_MISALIGN is set in the CSD.
 3. R1b: R1 response with an optional trailing busy signal.
 4. The data transferred must not cross a physical block boundary unless WRITE_BLK_MISALIGN is set in the CSD.
 5. 32 write protection bits (representing 32 write protect groups starting at the specified address) followed by 16 CRC bits are transferred in a payload format via the data line. The last (least significant) bit of the protection bits corresponds to the first addressed group. If the addresses of the last groups are outside the valid range, then the corresponding write protection bits shall be set to zero.

HB288064MM1

Responses

There are several types of response tokens. As in the MultiMediaCard mode, all are transmitted MSB first:

- Format R1

This response token is sent by the card after every command with the exception of SEND_STATUS commands. It is one byte long, and the MSB is always set to zero. The other bits are error indications, an error being signaled by a '1'. The structure of the R1 format is given in Figure "R1 Response Format". The meaning of the flags is defined as following:

- **In idle state:** The card is in idle state and running the initializing process.
- **Erase reset:** An erase sequence was cleared before executing because an out of erase sequence command was received.
- **Illegal command:** An illegal command code was detected.
- **Communication CRC error:** The CRC check of the last command failed.
- **Erase sequence error:** An error in the sequence of erase commands occurred.
- **Address error:** A misaligned address, which did not match the block length, was used in the command.
- **Parameter error:** The command's argument (e.g. address, block length) was out of the allowed range for this card.

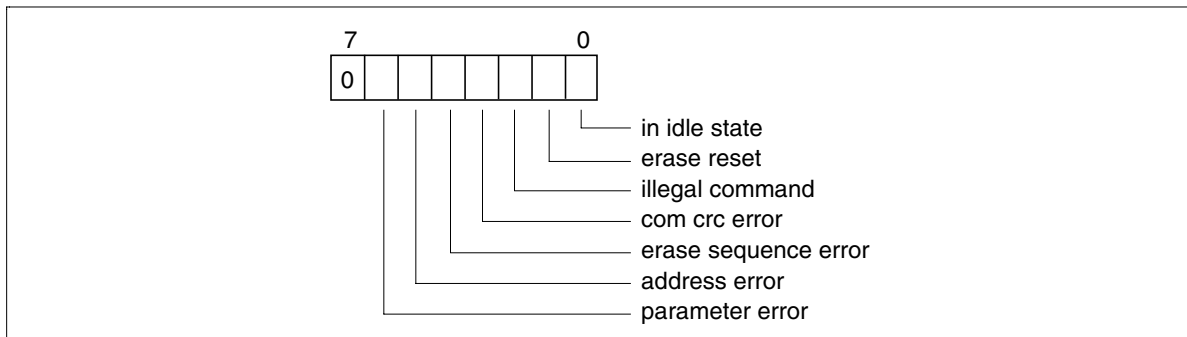

R1 Response Format

- Format R1b

This response token is identical to the R1 format with the optional addition of the busy signal. The busy signal token can be any number of bytes. A zero value indicates card is busy. A non-zero value indicates the card is ready for the next command.

- Format R2

This response token is two bytes long and sent as a response to the SEND_STATUS command. The format is given in Figure “R2 Response Format”.

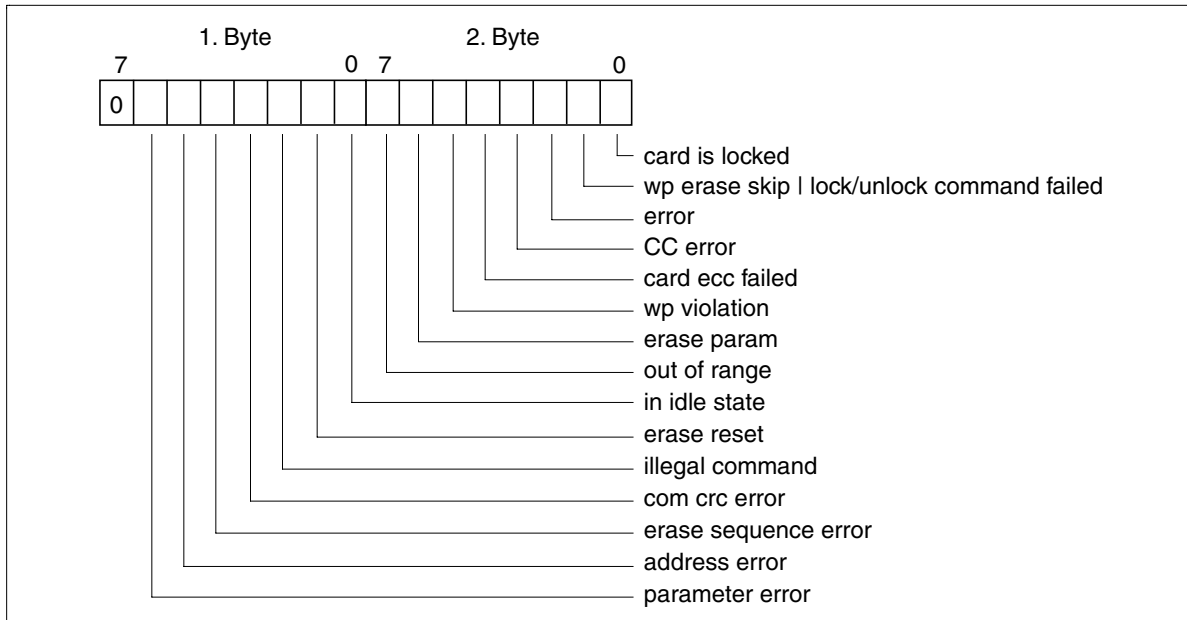

R2 Response Format

The first byte is identical to the response R1. The content of the second byte is described in the following:

- **Erase param:** An invalid selection, sectors or groups, for erase.
- **Write protect violation:** The command tried to write a write protected block.
- **Card ECC failed:** Card internal ECC was applied but failed to correct the data.
- **CC error:** Internal card controller error
- **Error:** A general or an unknown error occurred during the operation.
- **Write protect erase skip | lock/unlock command failed:** This status bit has two functions overloaded. It is set when the host attempts to erase a write protected sector or if a sequence or password error occurred during card lock/unlock operation.
- **Card is locked:** Set when the card is locked by the user. Reset when it is unlocked.

HB288064MM1

- Format R3

This response token is sent by the card when a READ_OCR command is received. The response length is 5 bytes (refer to Figure “R3 Response Format”). The structure of the first (MSB) byte is identical to response type R1. The other four bytes contain the OCR register.

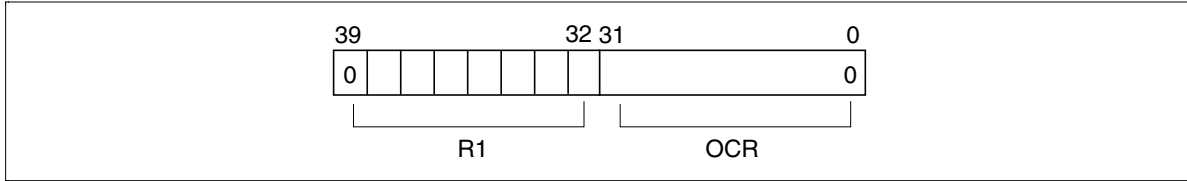

R3 Response Format

- Data Response

Every data block written to the card will be acknowledged by a data response token. It is one byte long and has the following format:

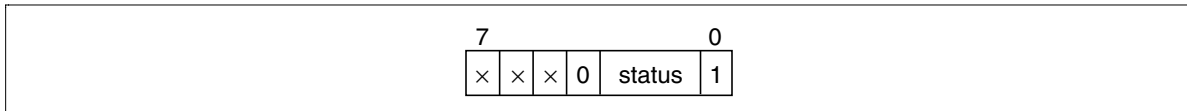

Data Response

The meaning of the status bits is defined as follows:

‘010’ - Data accepted.

‘101’ - Data rejected due to a CRC error.

Data Tokens

Read and write commands have data transfers associated with them. Data is being transmitted or received via data tokens. All data bytes are transmitted MSB first. Data tokens are 4 to 2051 bytes long and have the following format:

- First byte: Start Byte

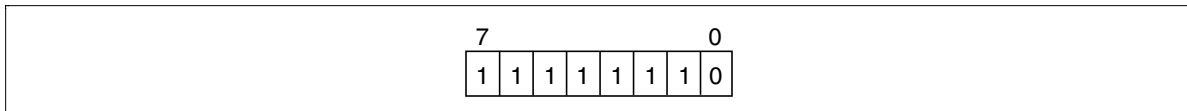

Data Tokens

- Bytes 2-2049 (depends on the data block length): User data
- Last two bytes: 16 bit CRC.

HITACHI

Data Error Token

If a read operation fails and the card cannot provide the required data, it will send a data error token instead. This token is one byte long and has the following format:

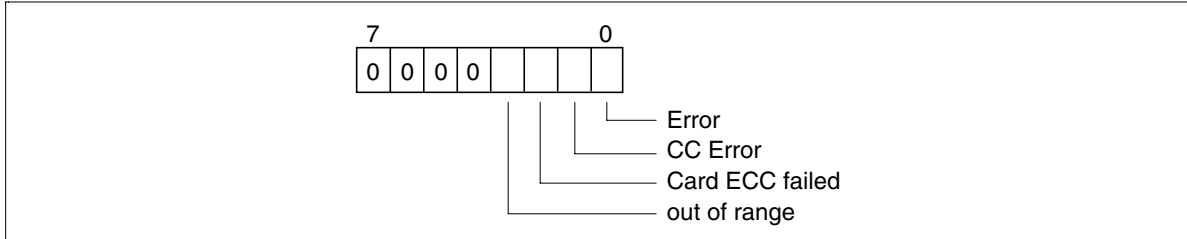
**Data Error Token**

The 4 least significant bits (LSB) are the same error bits as in the response format R2.

HB288064MM1

SPI Bus Timing

All timing diagrams use the following schematics and abbreviations:

H: Signal is high (logical '1')

L: Signal is low (logical '0')

X: Don't care

Z: High impedance state (-> = 1)

*: Repeater

Busy: Busy Token

Command: Command token

Response: Response token

Data block: Data token

All timing values are defined in Table "Timing Values". The host must keep the clock running for at least N_{CR} clock cycles after receiving the card response. This restriction applies to both command and data response tokens.

Command/Response

- Host Command to Card Response - Card is ready

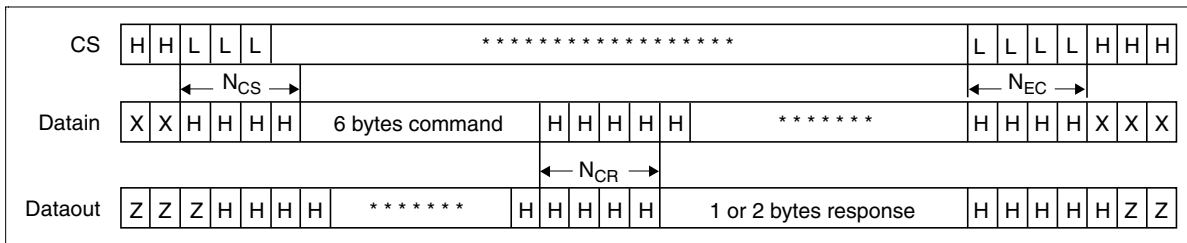

- Host Command to Card Response - Card is busy

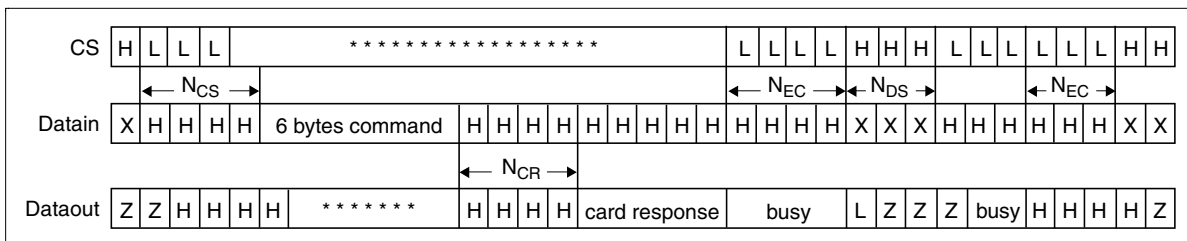

• Card Response to Host Command

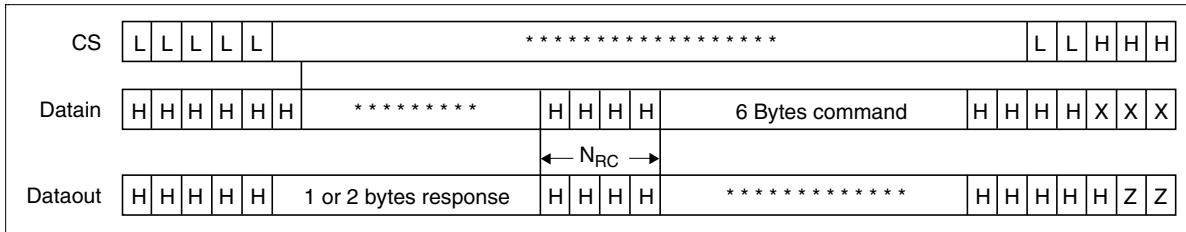

• Data Read

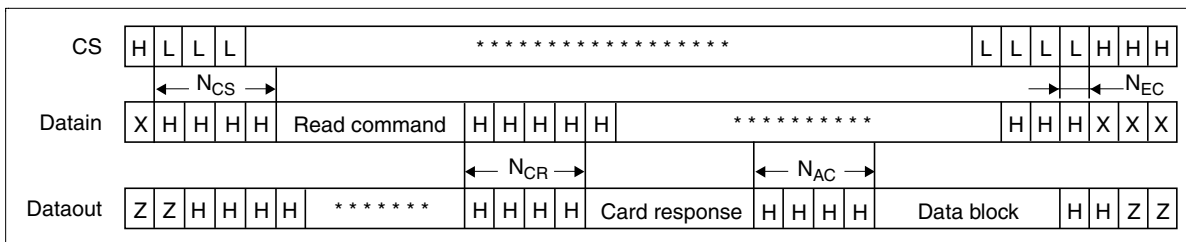

• Reading The CSD Register

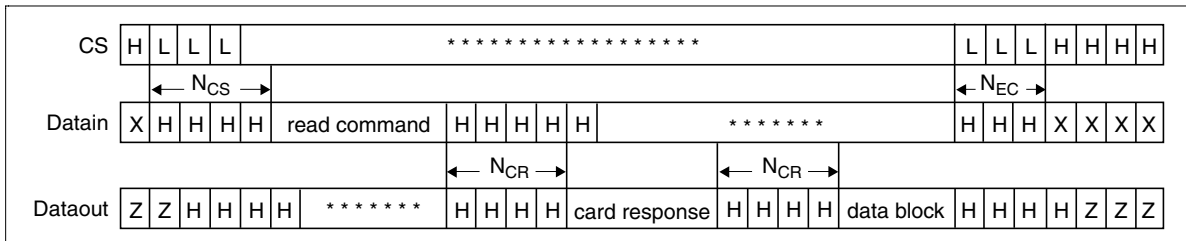

• Data Write

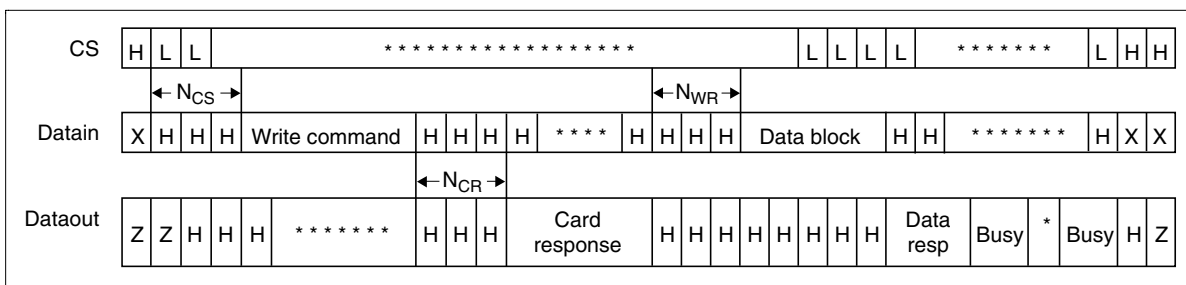

HB288064MM1

Timing Values

Symbol	Min	Max	Unit
N_{CS}	0	—	8 clock cycles
N_{CR}	1	8	8 clock cycles
N_{RC}	1	—	8 clock cycles
N_{AC}	1	spec. in the CSD* ¹	8 clock cycles
N_{WR}	1	—	8 clock cycles
N_{EC}	0	—	8 clock cycles
N_{DS}	0	—	8 clock cycles

Note: 1. Refer to Chapter “Time-out Condition”.

Error Handling

MultiMediaCards are defined as error free devices or as devices with a defined maximum bit error rate (with external error correction circuitry). To correct defects in the memory field of the cards the system may include error correction codes in the payload data (ECC). This correction is intended to correct static errors. Additionally two methods of detecting errors generated during the data transfer (dynamic errors) via a cyclic redundancy check (CRC) are implemented.

On Card Error Correction Code (ECC)

The HB288064MM1 is free of static errors. All errors are covered inside the card, even errors occurring during the lifetime of HB288064MM1 are covered for the user. The only effect which may be notified by the end user is, that the overall memory capacity may be reduced by small number of blocks. All flash handling is done on card, so that no external error correction is needed.

Cyclic Redundancy Check (CRC)

The intention of the ECC method is to protect the HB288064MM1 against permanent storage failures in the memory field of the card. To protect the data against errors generated during the transport over the MultiMediaCard bus dynamically, an additional feature is implemented: the cyclic redundancy check (CRC). Following the MultiMediaCard standard, the HB288064MM1 uses two different CRC codes to protect the data and the command/response transfer between card and host. Unlike the ECC, the CRC is intended only to detect transfer errors and not to correct them “on the fly”. When a CRC error is detected the host has to react. This is normally done by repeating the last command. The first CRC code is intended to protect the command and response frames. They are also used to synchronize the data stream. This CRC is generated with and checked against the following polynomial:

$$\text{CRC polynomial: } G(x) = x^7 + x^3 + 1$$

$$M(x) = (\text{start bit}) * x^{39} + \dots + (\text{last bit}) * x^0$$

$$\text{CRC}[6\dots0] = \text{Remainder} [(M(x) * x^7)/G(x)]$$

One CRC is checked in the HB288064MM1 for every command. For each response a CRC is generate in the HB288064MM1. Each data block read from the HB288064MM1 will be succeeded by redundancy bits generated with the second CRC. The code is usable for payload lengths of up to 2048 Bytes:

$$\text{CRC polynomial: } G(x) = x^{16} + x^{12} + x^5 + 1,$$

$$M(x) = (\text{start bit}) * x^n + x^{n-1} + \dots + (\text{last bit}) * x^0, \text{ with } n < 2048*8$$

$$\text{CRC}[15\dots0] = \text{Remainder} [(M(x) * x^{16}) / G(x)]$$

Both CRCs are mandatory for the card and the host.

Power Supply

Power Supply Decoupling

The V_{SS1} , V_{SS2} and V_{CC} lines supply the card with operating voltage. For this, decoupling capacitors for buffering current peak are used. These capacitors are placed on the bus side corresponding to Figure “Power Supply Decoupling”.

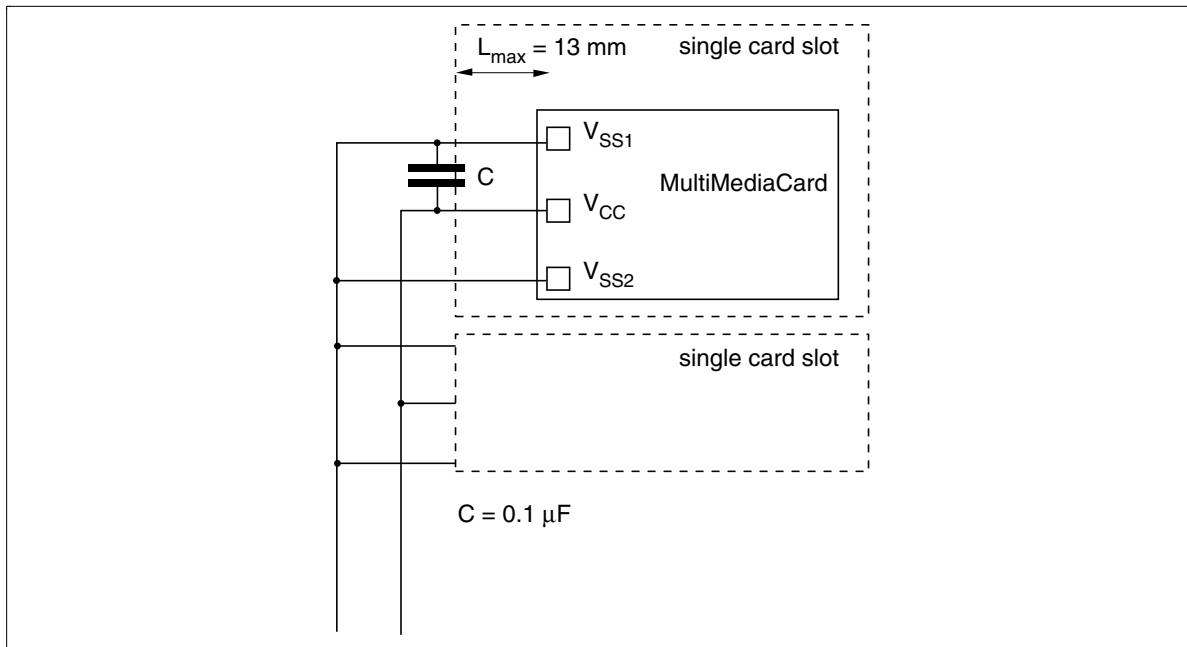

Power Supply Decoupling

The host controller includes a central buffer capacitor for V_{CC} . Its value is $C_{buf} = 1 \mu\text{F/slot}$

Power on

Each card has its own power on detection circuitry which puts the card into a defined state after the power-on. No explicit reset signal is necessary. The cards can also be reset by a special software command: GO_IDLE_STATE (CMD0). In case of emergency the host may also reset the cards by switching the power supply off and on again.

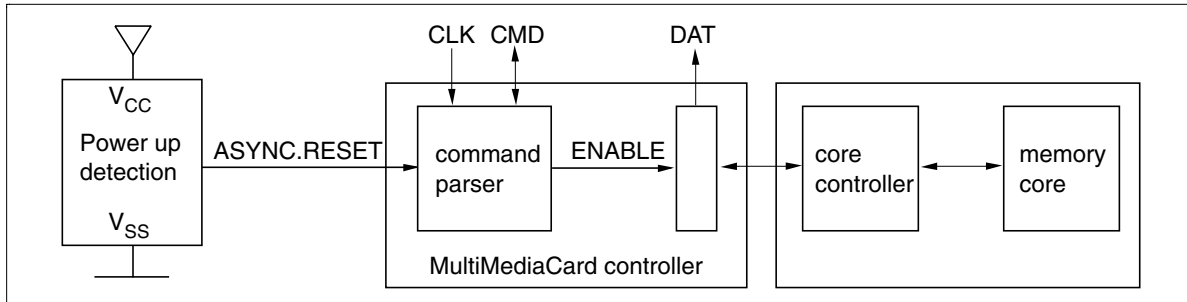
**Power on Detection**

A power on reset is generated on chip as long as V_{CC} is below a certain limit. After this reset the command parser of the HB288064MM1 works properly but the access to the memory core is not guaranteed. So in the power up phase (or when the HB288064MM1 is inserted during power up) the host has to wait after sending SEND_OP_COND (CMD1) for the identification delay before the ALL_SEND_CID (CMD2) can be interpreted by the card:

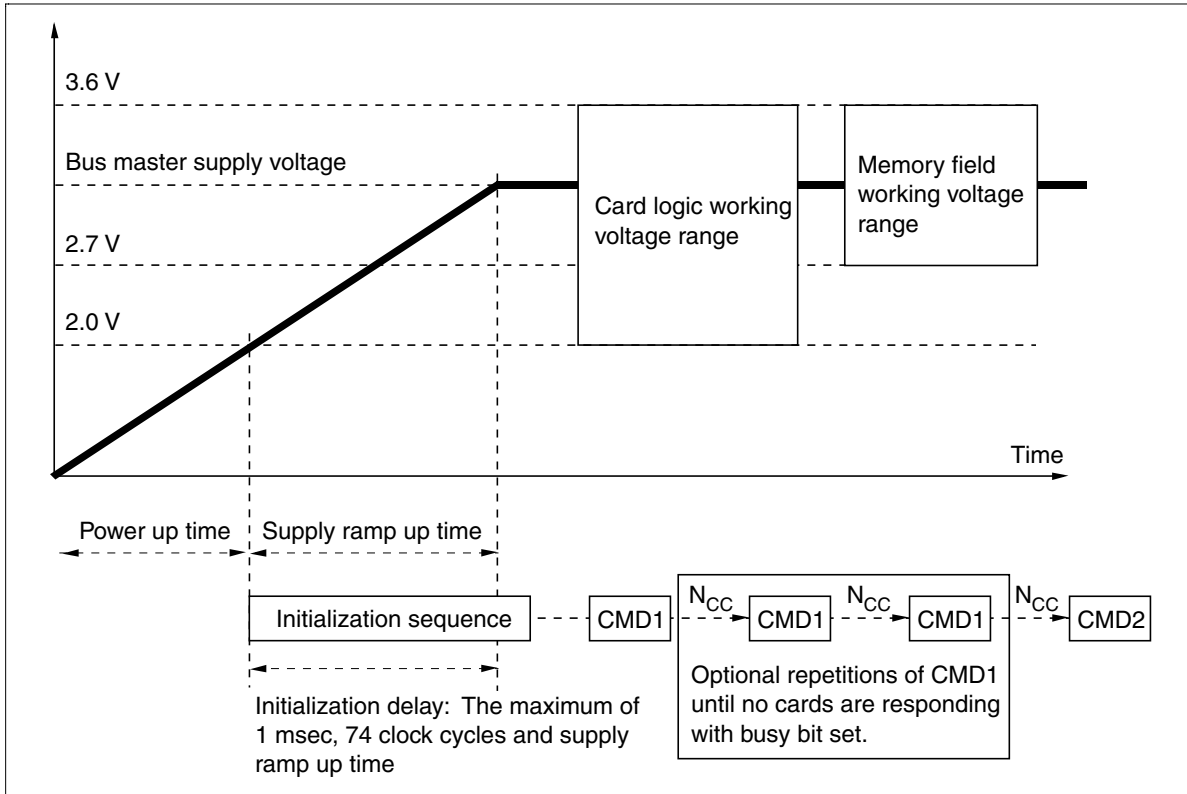

Power-up Diagram

- After power up (including hot insertion, i.e. inserting a card when the bus is operating) the MultiMediaCard enters the idle state. During this state the MultiMediaCard ignores all bus transactions until CMD1 is received.
- CMD1 is a special synchronization command used to negotiate the operation voltage range and to poll the cards until they are out of their power-up sequence. Besides the operation voltage profile of the cards, the response to CMD1 contains a busy flag, indicating that the card is still working on its power-up procedure and is not ready for identification. This bit informs the host that at least one card is not ready. The host has to wait (and continue to poll the cards) until this bit is cleared.
- Getting individual cards, as well as the whole MultiMediaCard system, out of idle state is up to the responsibility of the bus master. Since the power up time and the supply ramp up time depend on application parameters such as the maximum number of MultiMediaCards, the bus length and the power supply unit, the host must ensure that the power is built up to the operating level (the same level which will be specified in CMD1) before CMD1 is transmitted.
- After power up the host starts the clock and sends the initializing sequence on the CMD line. This sequence is a contiguous stream of logical '1's. The sequence length is the maximum of 1 msec, 74 clocks or the supply-ramp-up-time; The additional 10 clocks (over the 64 clocks after what the card should be ready for communication) are provided to eliminate power-up synchronization problems.

Short Cut Protection

The HB288064MM1 can be inserted/removed into/from the bus without damage. If one of the supply pins (V_{CC} or V_{SS}) is not connected properly, then the current is drawn through a data line to supply the card. Naturally the card can not operate properly under this conditions.

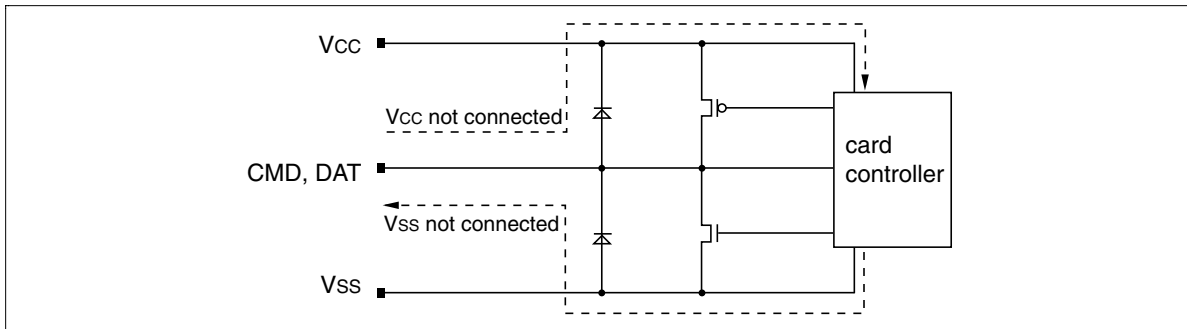
**Improper Power Supply**

Every HB288064MM1 output withstands shortcuts to either supply.

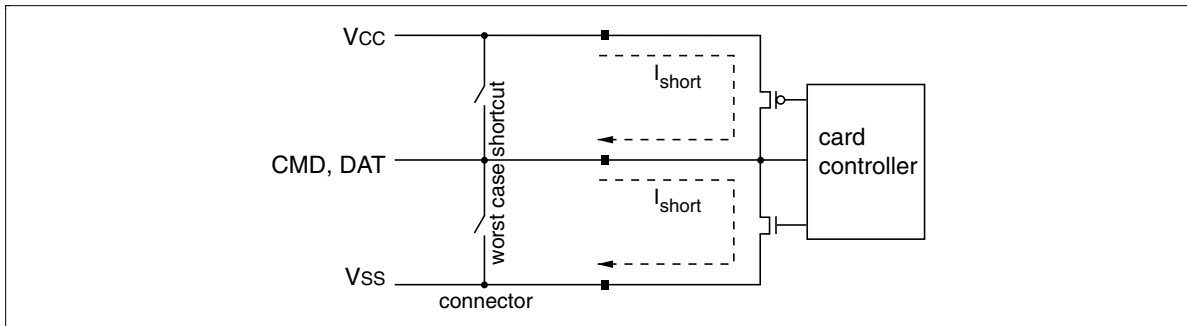
**Short Cut Protection**

HB288064MM1

Characteristics

This chapter defines following characteristics:

- Temperature characteristics
- Electrical characteristics

Temperature Characteristics

Parameter	Symbol	Min	Max	Unit
Storage temperature		-40	85	°C
Operating temperature		-25	85	°C
Junction temperature		-20	95	°C

Electrical Characteristics

In this chapter the electrical characteristics for the HB288064MM1 are defined in three steps:

- Pad characteristics: properties of the external connectors
- Absolute maximum ratings: if exceeded the card may be damaged
- Recommended operating conditions: characterization model of the environment of the HB288064MM1, requirements for the operating characteristics
- Operating characteristics: properties of the HB288064MM1 measurable if the recommended operating conditions are considered

Pad Characteristics

Parameter	Symbol	Min	Typ	Max	Unit
Input capacitance				7	pF

Absolute Maximum Ratings

Absolute maximum ratings are those values beyond which damage to the device may occur. Functional operation under these conditions or at any other condition beyond those indicated in the operational sections of this specification is not implied:

Parameter	Symbol	Min	Max	Unit	Remark	
Supply voltage	V_{CC}	-0.5	4.6	V		
Total power dissipation			0.2	W		
ESD protection		-4	4	kV	Human body model	
Inputs	Input voltage	$V_{I\max}$	-0.5	$V_{CC} + 0.5$	V	$\leq \max(V_{CC})$
Outputs	Output voltage	$V_{O\max}$	-0.5	$V_{CC} + 0.5$	V	$\leq \max(V_{CC})$
	High-level output current	$I_{OH\max}$	-100		mA	short cut protected
	Low-level output current	$I_{OL\max}$		150	mA	short cut protected

Bus Signal Line Load

The total capacitance C_L of each line of the MultiMediaCard bus is the sum of the bus master capacitance C_{HOST} , the bus capacitance C_{BUS} itself and the capacitance C_{CARD} of each card connected to this line:

$$C_L = C_{HOST} + C_{BUS} + N \cdot C_{CARD}$$

where N is the number of connected cards. Requiring the sum of the host and bus capacitance's not to exceed 30 pF for up to 10 cards, and 40 pF for up to 30 cards, the following values must not be exceeded:

Parameter	Symbol	Min	Max	Unit	Remark
Pull-up resistance for CMD	R_{CMD}	4.7	100	k Ω	to prevent bus floating
Pull-up resistance for DAT	R_{DAT}	50	100	k Ω	to prevent bus floating
Bus signal line capacitance	C_L	—	250	pF	$f_{pp} \leq 5$ MHz, 30 cards
Bus signal line capacitance	C_L	—	100	pF	$f_{pp} \leq 20$ MHz, 10 cards
Single card capacitance	C_{CARD}	—	7	pF	
Maximum signal line inductance		—	16	nH	$f_{pp} \leq 20$ MHz

HB288064MM1

Recommended Operating Conditions

The recommended operating conditions define the parameter ranges for optimal performance and durability of the HB288064MM1.

Parameter	Symbol	Min	Typ	Max	Unit	Remark	
Supply voltage	V_{CC}	2.7	3.0	3.6	V		
Inputs	Low-level input current	V_{IL}	$V_{SS} - 0.3$	$0.25V_{CC}$	V		
	High-level input current	V_{IH}	$0.625V_{CC}$	$V_{CC} + 0.3$	V		
Outputs	High-level output current	I_{OH}	-2		mA		
	Low-level output current	I_{OL}		6	mA		
Clock input clk* ¹	Clock frequency data transfer mode (pp)	f_{PP}	0	20	MHz	$C_L < 100$ pF (10 cards)	
	Clock frequency ident. mode (od)	f_{OD}	0	400	kHz		
	Clock cycle time data transfer mode (pp)	$t_{PP} = 1/f_{PP}$	50			ns	
	Clock cycle time ident. mode (od)	$t_{OD} = 1/f_{OD}$	2.5			μs	
	Clock low time	t_{WL}	10			ns	$C_L < 100$ pF (10 cards)
	Clock high time	t_{WH}	10			ns	$C_L < 100$ pF (10 cards)
	Clock input rise time	t_{LH}			10	ns	$C_L < 100$ pF (10 cards)
	Clock input fall time	t_{HL}			10	ns	$C_L < 100$ pF (10 cards)
	Clock low time	t_{WL}	50			ns	$C_L < 250$ pF (30 cards)
	Clock high time	t_{WH}	50			ns	$C_L < 250$ pF (30 cards)
	Clock input rise time	t_{LH}			50	ns	$C_L < 250$ pF (30 cards)
	Clock input fall time	t_{HL}			50	ns	$C_L < 250$ pF (30 cards)

Note: 1. All values are referred to min (V_{IH}) and max (V_{IL}).

Operating Characteristics

The operating characteristics are parameters measured in a MultiMediaCard system assuming the recommended operating conditions (refer to Chapter “Recommended Operating Conditions”).

Parameter	Symbol	Min	Typ	Max	Unit	Remark
High speed supply current				45	mA	at 20 MHz, 3.6 V
Minimal supply current				150	μA	at 0 Hz, 3.6 V stby state
All digital inputs (Including I/O current)	Input leakage current	-10		10	μA	
All outputs	High-level output voltage	V_{OH}	$0.75V_{CC}$		V	at min I_{OH}
	Low-level output voltage	V_{OL}		$0.125V_{CC}$	V	at max I_{OL}
Inputs: CMD, DAT (Referred to CLK), DI (Referred to SCLK), CS	Input set-up time	t_{ISU}	3		ns	
	Input hold time	t_{IH}	3		ns	
Outputs: CMD, DAT (Referred to CLK), DO (Referred to SCLK)	Output set-up time	t_{OSU}	5		ns	
	Output hold time	t_{OH}	5		ns	at $t_{LH} = 10$ ns

HB288064MM1

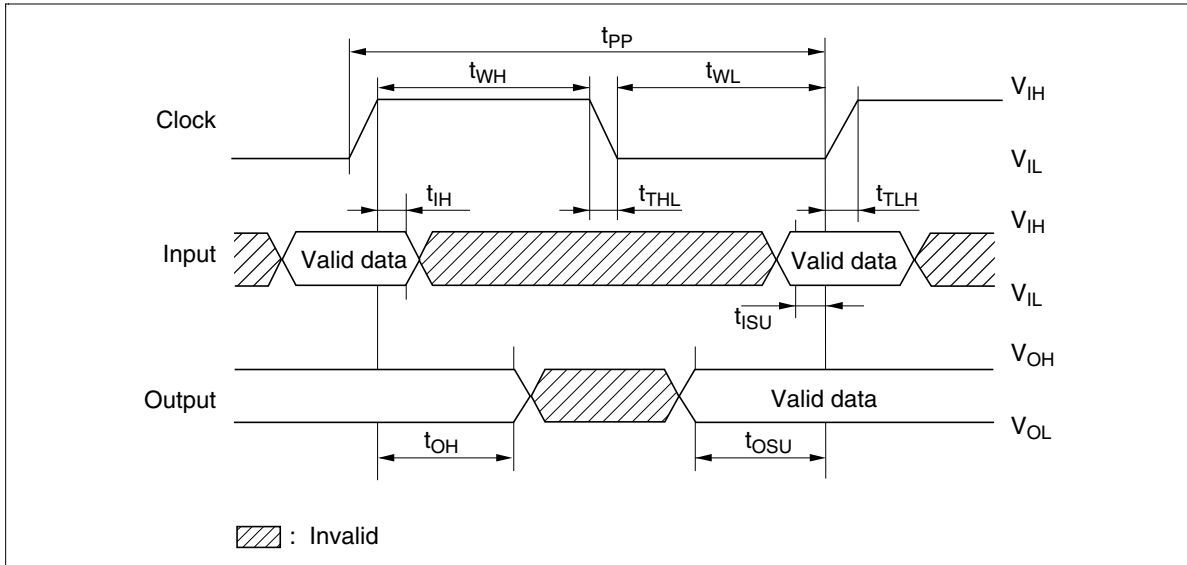

Timing Diagram of Data Input and Output

The access time (t_{AT}) is divided into two parts:

- T_{SAD} : The synchronous access time. This time defines the time of the maximum number of cycles which are required to access a byte of the memory field.
- T_{AAD} : The asynchronous access time to read a byte out of the memory field.

The synchronous part of the access time is sum of the command frame length and some additional internal cycles ($N_{SAD} = 16$ cycles). At 20 MHz one cycle is 50 ns ($1/f_{CLK}$), multiplied with N_{SAD} the resulting frame time is $T_{SAD} = 0.8 \mu s$. The asynchronous access delay of the HB288064MM1 is $T_{AAD} = 300 \mu s$ maximum. The resulting memory access time t_{AT} is the sum of both parts:

$$t_{AT} = T_{AAD} + T_{SAD} \quad \text{with} \quad T_{SAD} = N_{SAD}/f_{CLK}$$

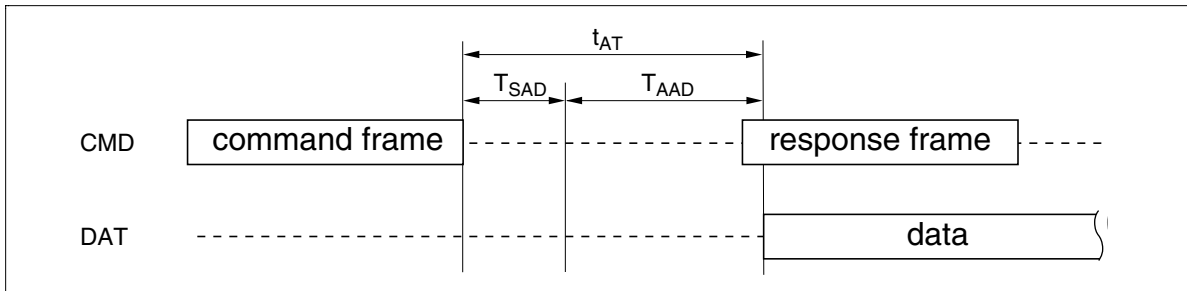

Access Time

Access Time

Parameter	Symbol	Typ	Max	Unit	Remark
Synchronous access delay cycles	N_{SAD}	—	16	cycles	
Synchronous access delay	T_{SAD}	—	0.8	μs	at 20 MHz clock frequency
Asynchronous access delay	T_{AAD}	300	—	μs	
Memory access time	t_{AT}	300.8	— ^{*1}	μs	at 20 MHz clock frequency

Note: 1. Refer to Chapter “Time-out Condition”.

In the CSD are two fields to code the asynchronous and the synchronous access delay time:

- TAAC, asynchronous access delay
- NSAC, maximum number of cycles for receiving and interpreting of a command frame

The value for the CSD field NSAC is calculated from N_{SAD} (maximum: 16 cycles) by division with 100 and rounding up to the next integer:

$$NSAC = \lceil N_{SAD}/100 \rceil = \lceil 16/100 \rceil$$

- NSAC = 0x01

The value for the CSD field TAAC is 1 ms:

$$TAAC = \lceil T_{AAD} \rceil = 1 \text{ ms}$$

- TAAC = 0x0E

For more details on NSAC and TAAC CSD-entries refer to Chapter “Card Specific Data (CSD)”.

References

[1] The MultiMediaCard, System Specification 2.11, MultiMediaCard Association

Number Representations

- decimal numbers: 1234, no special characters
- hexadecimal numbers: 0xAB, leading 0x, each digit represents 4 bits.
- binary numbers (single bit): ‘0’.
- binary number (unsigned bit vector): “100100”.
- 1k is equal to 1024.
- 1M is equal to 1k*1k.

HB288064MM1

Abbreviations and Terms

Abbreviations	Terms
<n>	Argument of a command or data field.
CMD<n>	MultiMediaCard bus command <n>. See Command.
PP	Push Pull, output driver type with low impedance driver capability for 0 and 1.
OD	Open Drain, output driver type with low impedance driver capability for 0 and high impedance driver capability for 1.
CSD	Card specific data, MultiMediaCard register to store operating parameters.
CID	Card identification data, MultiMediaCard register for the card initialization procedure.
RCA	Relative card address, MultiMediaCard register which contains the current card address of an initialized MultiMediaCard.
OCR	Operation condition register, MultiMediaCard register that contains the voltage window which is supported by the MultiMediaCard.
DSR	Driver stage register, control register for the programmable driver stage driver (PDS).
PDS	Programmable driver stage driver, is a tri-state output driver which has is programmable to adapt the driver capabilities to the bus design.
Command	A command send from the MultiMediaCard host to one or more MultiMediaCard cards
Response	A response is always sent from the card to the host. It is always initiated by a command (Remark: not all commands enforce responses).
Broadcast Com.	A command may send as broadcast or as an addressed command. A broadcast command is sent to all cards connected to the MultiMediaCard bus simultaneous.
Addressed Com.	An addressed command is sent to exactly one selected MultiMediaCard. Normally an addressed command forces a response of the card.
Point to point C.	Same as addressed command
DAT	The data (input)/output signal of the MultiMediaCard.
CLK	The clk input signal of the MultiMediaCard.
CMD	The command/response input/output of the MultiMediaCard.
V _{SS1,2}	Ground contacts/lines of the MultiMediaCard.
V _{CC}	Supply voltage contact/line of the MultiMediaCard.
Memory core	Array of memory cells in the core of the MultiMediaCard.
MultiMediaCard interface	MultiMediaCard command interpreter module.
MID	Manufacturer Identifier.

Abbreviations	Terms
CIN	Card individual number.
CRC	Cyclic redundancy check.
ECC	Error correction code.
G(x)	Generator polynomial of error correction/check code.
TAC	Asynchronous access delay
NAC	Number of synchronous access cycles to be added to the access delay
f _{OD}	Open drain mode operating frequency (maximum 400kHz).
f _{PP}	Push pull mode operating frequency (maximum 20MHz).
MSB	Most significant bit.
LSB	Least significant bit.
Human Body Model	Standard model to simulate electrical conditions induced by handling and touching of electrical devices by humans.

HB288064MM1

Physical Outline

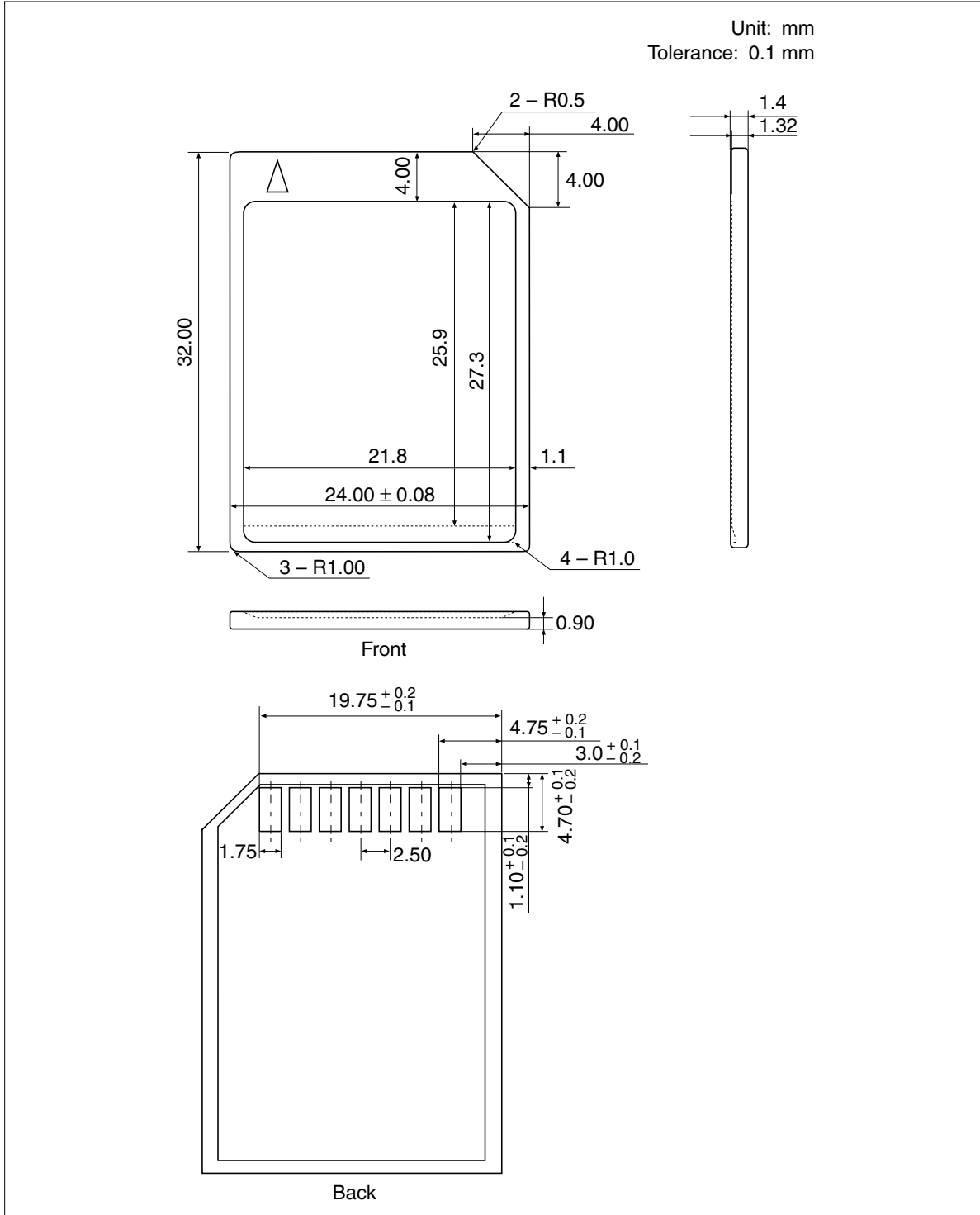

HITACHI

Cautions

1. Hitachi neither warrants nor grants licenses of any rights of Hitachi's or any third party's patent, copyright, trademark, or other intellectual property rights for information contained in this document. Hitachi bears no responsibility for problems that may arise with third party's rights, including intellectual property rights, in connection with use of the information contained in this document.
2. Products and product specifications may be subject to change without notice. Confirm that you have received the latest product standards or specifications before final design, purchase or use.
3. Hitachi makes every attempt to ensure that its products are of high quality and reliability. However, contact Hitachi's sales office before using the product in an application that demands especially high quality and reliability or where its failure or malfunction may directly threaten human life or cause risk of bodily injury, such as aerospace, aeronautics, nuclear power, combustion control, transportation, traffic, safety equipment or medical equipment for life support.
4. Design your application so that the product is used within the ranges guaranteed by Hitachi particularly for maximum rating, operating supply voltage range, heat radiation characteristics, installation conditions and other characteristics. Hitachi bears no responsibility for failure or damage when used beyond the guaranteed ranges. Even within the guaranteed ranges, consider normally foreseeable failure rates or failure modes in semiconductor devices and employ systemic measures such as fail-safes, so that the equipment incorporating Hitachi product does not cause bodily injury, fire or other consequential damage due to operation of the Hitachi product.
5. This product is not designed to be radiation resistant.
6. No one is permitted to reproduce or duplicate, in any form, the whole or part of this document without written approval from Hitachi.
7. Contact Hitachi's sales office for any questions regarding this document or Hitachi semiconductor products.

HITACHI**Hitachi, Ltd.**

Semiconductor & Integrated Circuits.
Nippon Bldg., 2-6-2, Ohte-machi, Chiyoda-ku, Tokyo 100-0004, Japan
Tel: Tokyo (03) 3270-2111 Fax: (03) 3270-5109

URL NorthAmerica : <http://semiconductor.hitachi.com/>
 Europe : <http://www.hitachi-eu.com/hel/ecg>
 Asia : <http://www.hitachi.com.sg/grp3/sicd>
 Japan : <http://www.hitachi.co.jp/Sicd/indx.htm>

For further information write to:

Hitachi Semiconductor
(America) Inc.
179 East Tasman Drive,
San Jose, CA 95134
Tel: <1> (408) 433-1990
Fax: <1> (408) 433-0223

Hitachi Europe GmbH
Electronic Components Group
Dornacher Straße 3
D-85622 Feldkirchen, Munich
Germany
Tel: <49> (89) 9 9180-0
Fax: <49> (89) 9 29 30 00

Hitachi Europe Ltd.
Electronic Components Group.
Whitebrook Park
Lower Cookham Road
Maidenhead
Berkshire SL6 8YA, United Kingdom
Tel: <44> (1628) 585000
Fax: <44> (1628) 585160

Hitachi Asia Ltd.
16 Collyer Quay #20-00
Hitachi Tower
Singapore 049318
Tel: 535-2100
Fax: 535-1533

Hitachi Asia Ltd.
Taipei Branch Office
3rd Flr, Hung Kuo Building, No.167,
Tun Hwa North Road, Taipei (105)
Taiwan
Tel: <886> (2) 2718-3666
Fax: <886> (2) 2718-8180
Telex: 23222 HAS-TP

Hitachi Asia (Hong Kong) Ltd.
Group III (Electronic Components)
7th Flr, North Tower, World Finance Centre,
Harbour City, Canton Road, Tsim Sha Tsui,
Kowloon, Hong Kong
Tel: <852> (2) 735 9218
Fax: <852> (2) 730 0281
Telex: 40815 HITEC HX

Copyright © Hitachi, Ltd., 2000. All rights reserved. Printed in Japan.
Colophon 1.0

HITACHI

HB288064MM1

Revision Record

Rev.	Date	Contents of Modification	Drawn by	Approved by
0.0	Jul. 25, 2000	Initial issue		
