

INTELLIGENT POWER SWITCH

ADVANCE DATA

- 0.5A OUTPUT CURRENT
- LOW SIDE OR HIGH SIDE SWITCH CONFIGURATION
- 6V TO 48V SUPPLY VOLTAGE RANGE
- OVERLOAD AND SHORT CIRCUIT PROTECTIONS
- INTERNAL VOLTAGE CLAMPING
- SUPPLY AND OUTPUT REVERSAL PROTECTION
- THERMAL SHUTDOWN
- GND AND V_s OPEN WIRE PROTECTION
- ADJUSTABLE DELAY AT SWITCH ON
- INDICATOR STATUS LED DRIVER
- +5V REGULATED AUX. VOLTAGE

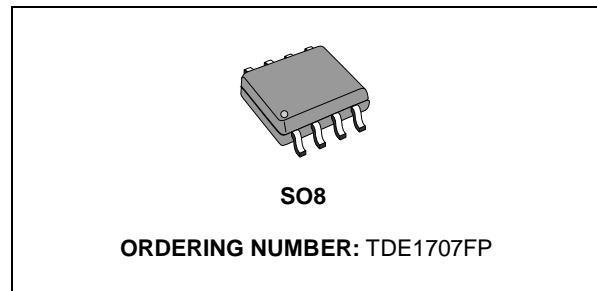

DESCRIPTION

The TDE1707 is a 0.5A Integrated Power Switch with up to 48V Power supply capability.

Two output configurations are possible:

- Load to Gnd. (High Side Mode)
- Load to V_s (Low side Mode)

Especially dedicated to proximity detectors, its in-

ternal +5V supply can be used to supply external circuits (See also AN495/0692). A signal is internally generated to block the In signal, and prevent activation of the output switch, as long as an abnormal condition is detected. The power-on transition, as well as the chip overtemperature and the output overcurrent, concur to the generation of such signal. A minimum delay of 25 μ s (Typ. value) is added to the trailing edge of such signal to ensure that a stable normal situation is present when the signal disappears. The delay (of the disappearance of the block signal; no delay at its on set) can be further increased connecting a capacitor between pin3 and ground. It can drive resistive or inductive loads.

BLOCK DIAGRAM

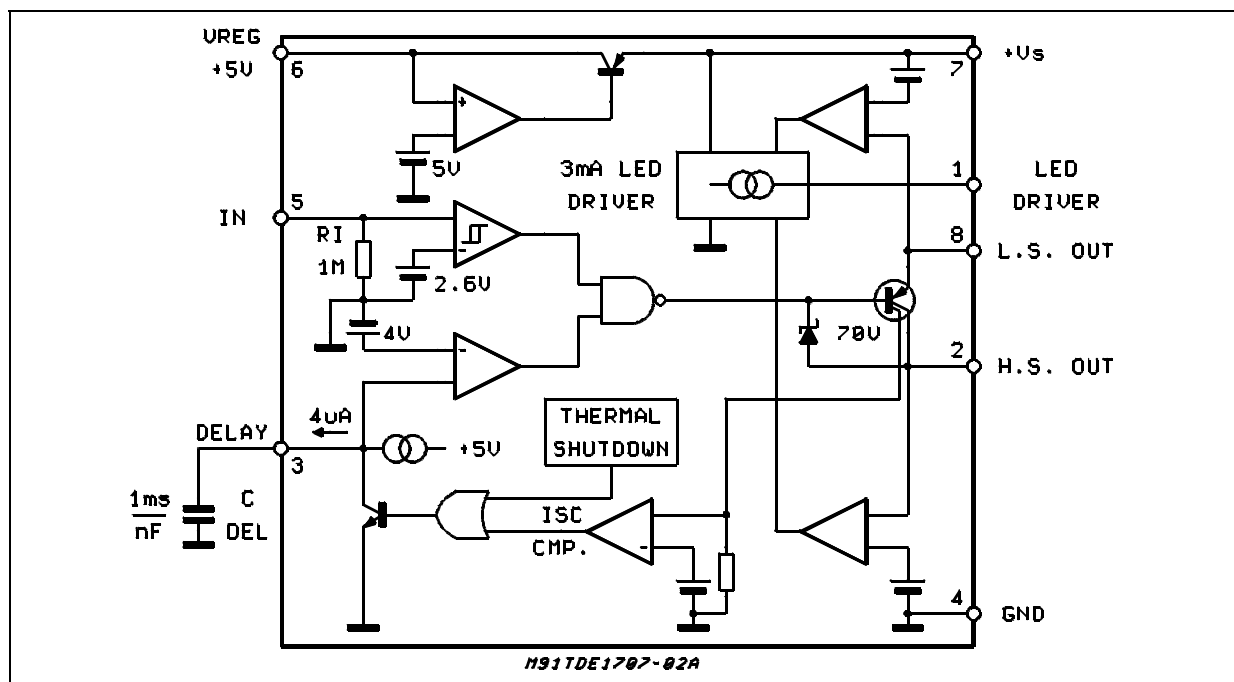

TDE1707

PIN CONNECTION (Top view)

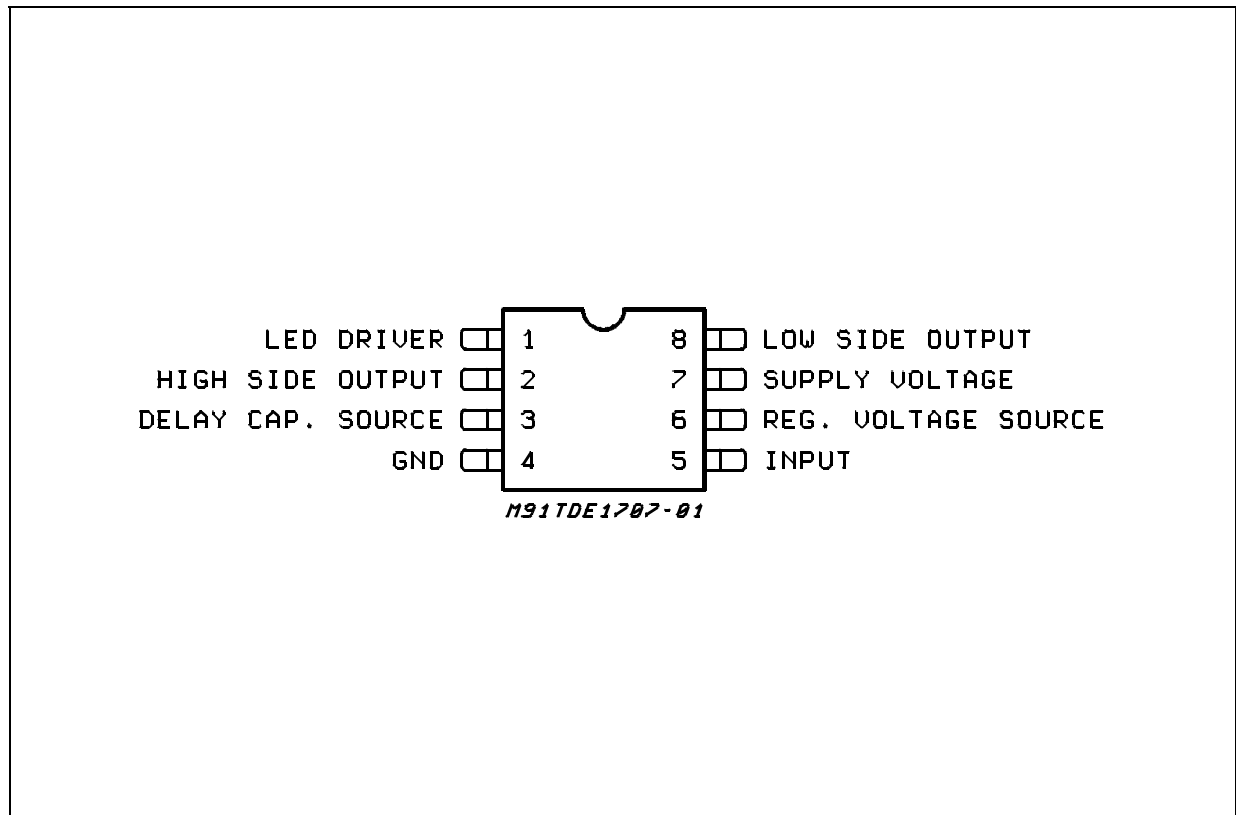

ABSOLUTE MAXIMUM RATINGS

| Symbol | Parameter | Value | Unit |
|-------------|-----------------------------|--------------------|------|
| V_S | Supply Voltage | 50 | V |
| V_{Sr} | Supply Reverse Voltage | 50 | V |
| I_O | Output Current | internally limited | A |
| V_{reg} | Regulated Voltage Pin | 0 to 7 | V |
| V_{delay} | Delay Cap. Surce Pin | 0 to 5 | V |
| V_O | Output Diff. Voltage | 55 | V |
| V_i | Input Voltage | -10 to 50 | V |
| T_{op} | Operating Temperature Range | -25 to +85 | °C |
| T_{stg} | Storage Temperature | -55 to 150 | °C |
| P_{tot} | Power Dissipation | internally limited | W |
| E_l | Energy Induct. Load | 150 | mJ |

THERMAL DATA

| Symbol | Description | Value | Unit |
|-----------------|-------------------------------------|----------|------|
| $R_{th\ j-amb}$ | Thermal Resistance Junction-ambient | Max. 150 | °C/W |

ELECTRICAL CHARACTERISTICS ($V_S = 24V$; $T_J = -25$ to $+85^\circ C$, unless otherwise specified)

| Symbol | Parameter | Test Condition | Min. | Typ. | Max. | Unit |
|---------------|-------------------------------|--|------|------|------------|--------------------|
| V_S 7 | Supply Voltage | | 6 | | 48 | V |
| I_{SR} 7 | Supply Reverse Current | $V_{SR} = -48V$ | | | 1.5 | mA |
| I_q 7 | Quiescent Current | $I_{reg} = I_{led} = 0$; $V_i < 2V$; $V_S = 6$ to $48V$ | | | 1.5 | mA |
| I_o 8/2 | Output Current | $V_S = 6V$ to $32V$ | | | 500 | mA |
| I_o 8/2 | Output Current | $V_S = 32V$ to $48V$ | | | 300 | mA |
| V_{sat} 8/2 | Output Voltage Drop V_{8-2} | $I_o = 500mA$ | | 1.1 | 1.6 | V |
| V_{sat} 8/2 | Output Voltage Drop V_{8-2} | $I_o = 300mA$ | | | 1.5 | V |
| I_{sc} 8/2 | Short Circuit Current | | 0.5 | 0.8 | 2 | A |
| V_{cl} 8/2 | Internal Voltage Clamp | $I_{CL} = 10mA$ | 55 | 65 | | V |
| I_{olk} 8/2 | Output Leakage | (Pin 2) $V_i < 2V$; $V_o = 0$ to V_S (Pin 8) | | 100 | 300 100 | μA μA |
| V_{ith} 5 | Input Voltage Threshold | | 2 | | 3 | V |
| V_{ihis} 5 | Input Threshold Hysteresis | | | 300 | | mV |
| I_{lk} 5 | Input Current | $V_i = 5V$ | | 2 | 5 | μA |
| V_{reg} 6 | Regulated Output Voltage | $I_{reg} < 5mA$ | 4.5 | 5 | 5.5 | V |
| I_{scr} 6 | Short Circuit Regulated | | 6 | 30 | 50 | mA |
| I_{reg} 6 | Output Regulator Current | $V_S = 35V$ $V_S = 48V$ | | | 6 4 | mA mA |
| I_{old} 1 | Current Surce Sink Led Driver | Output ON (\pm) | 2 | 3 | 4 | mA |
| V_{old} 1 | Voltage Drop Led Driver | $I_{os} = 2mA$ (\pm) | | 1.2 | 1.6 | V |
| Oldlk 1 | Lead Driver (off) Leak. | $V_i < 2V$; $R_L < 1K\Omega$ | | | 10 | μA |
| I_{dch} 3 | Del. Cap. Charge Current | $T_J = 25^\circ C$ | 2 | 4 | 6 | μA |
| V_{dth} 3 | Delay Voltage Trigger | $T_J = 25^\circ C$ | | 4 | | V |

APPLICATION INFORMATION (See Application Circuit)

The LED driver tells the output status.

It can source or sink current ($I_{old typ} = 3mA$), according to the output configuration chosen.

The thresholds, represented by the output comparator in the Block Diagram, are set at about 1.5V - 2V.

For instance, in the High Side Load case of the

Application Circuit, when the voltage on pin 8 (the output) differs from V_{CC} less than 1.5V, the output is sensed in "OFF" state and the LED driver is disabled.

If instead pin 8 differs from V_{CC} more than 3V (the output comparator threshold value plus the drop voltage on the LED), then the output is sensed "ON" and the driver will force the current on the LED.

DYNAMIC CHARACTERISTICS ($V_S = 24V$; $R_L = 48\Omega$; $T_J = 25^\circ C$)

| | | | | | | |
|-------------|--|-------------------|------|----|---|---------|
| t_{on} | Propagation Turn on Time | $V_i = 0$ to $5V$ | | 15 | | μs |
| t_{off} | Propagation Turn off Time | $V_i = 5$ to $0V$ | | 15 | | μs |
| t_{don} | Delayed Turn on Time / nF Delay Capacitor | | 0.65 | 1 | 2 | ms |
| $t_{d min}$ | Minimum Delayed t_{on} Delay Capacitor = 0 | | | 25 | | μs |

APPLICATION CIRCUIT

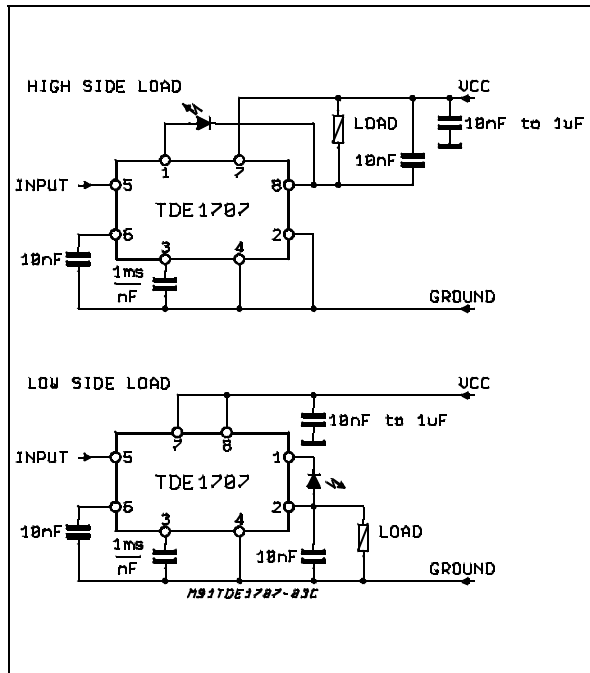

Figure 1: Input Thresholds Voltage vs. Temperature ($V_s = 24V$)

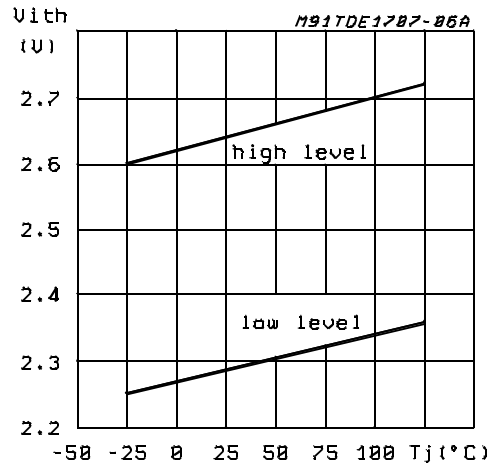

Figure 2: Saturation Voltage vs. Temperature ($V_s = 24V$; $I_o = 500mA$)

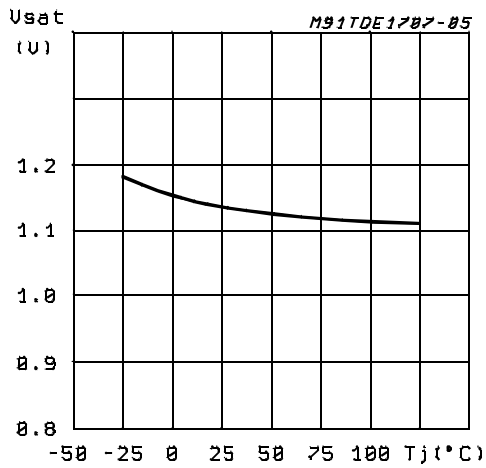
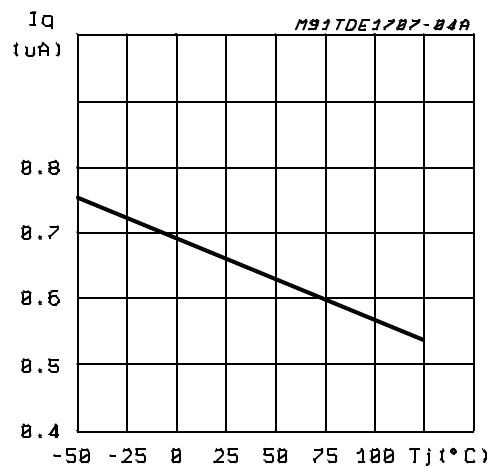
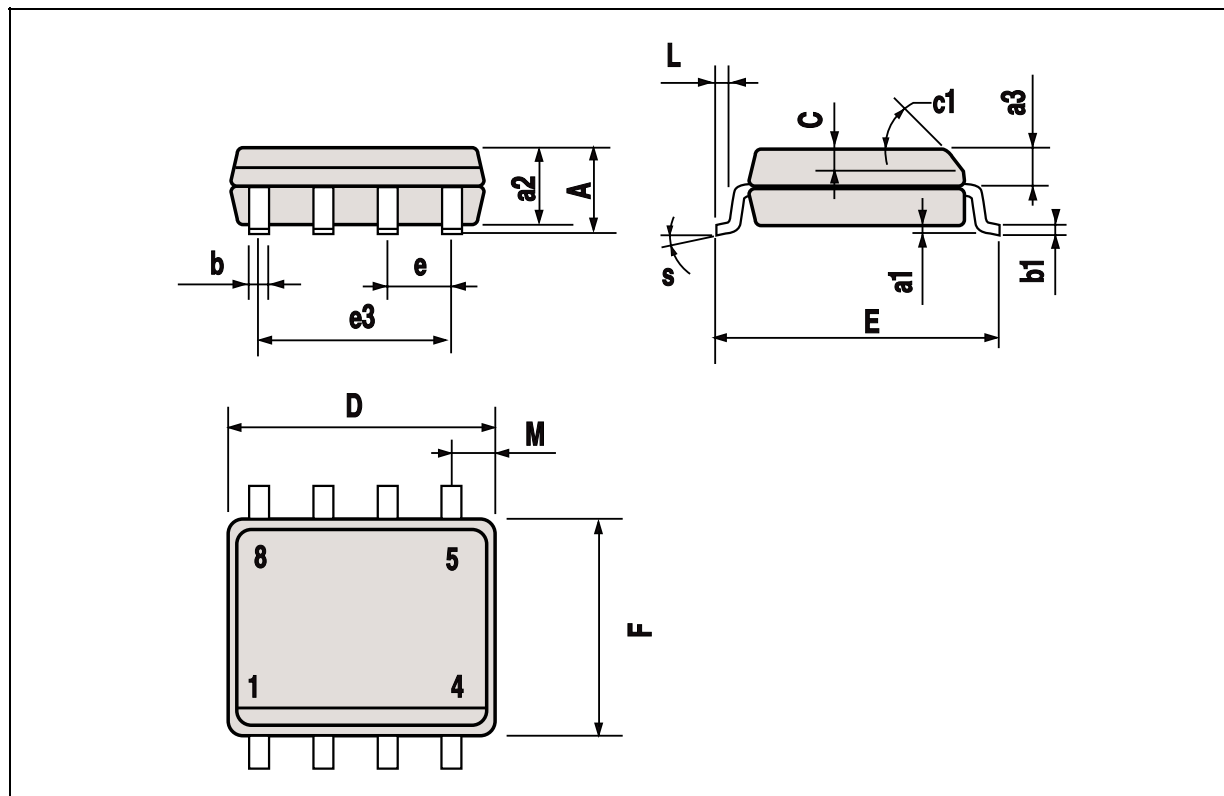

Figure 3: Quiescent Current (I_q) vs. Temperature ($V_s = 24V$)



SO8 PACKAGE MECHANICAL DATA

| DIM. | mm | | | inch | | |
|------|------------|------|------|-------|-------|-------|
| | MIN. | TYP. | MAX. | MIN. | TYP. | MAX. |
| A | | | 1.75 | | | 0.069 |
| a1 | 0.1 | | 0.25 | 0.004 | | 0.010 |
| a2 | | | 1.65 | | | 0.065 |
| a3 | 0.65 | | 0.85 | 0.026 | | 0.033 |
| b | 0.35 | | 0.48 | 0.014 | | 0.019 |
| b1 | 0.19 | | 0.25 | 0.007 | | 0.010 |
| C | 0.25 | | 0.5 | 0.010 | | 0.020 |
| c1 | 45° (typ.) | | | | | |
| D | 4.8 | | 5.0 | 0.189 | | 0.197 |
| E | 5.8 | | 6.2 | 0.228 | | 0.244 |
| e | | 1.27 | | | 0.050 | |
| e3 | | 3.81 | | | 0.150 | |
| F | 3.8 | | 4.0 | 0.15 | | 0.157 |
| L | 0.4 | | 1.27 | 0.016 | | 0.050 |
| M | | | 0.6 | | | 0.024 |
| S | 8° (max.) | | | | | |



Information furnished is believed to be accurate and reliable. However, SGS-THOMSON Microelectronics assumes no responsibility for the consequences of use of such information nor for any infringement of patents or other rights of third parties which may result from its use. No license is granted by implication or otherwise under any patent or patent rights of SGS-THOMSON Microelectronics. Specifications mentioned in this publication are subject to change without notice. This publication supersedes and replaces all information previously supplied. SGS-THOMSON Microelectronics products are not authorized for use as critical components in life support devices or systems without express written approval of SGS-THOMSON Microelectronics.

© 1994 SGS-THOMSON Microelectronics - All Rights Reserved

SGS-THOMSON Microelectronics GROUP OF COMPANIES

Australia - Brazil - France - Germany - Hong Kong - Italy - Japan - Korea - Malaysia - Malta - Morocco - The Netherlands - Singapore - Spain - Sweden - Switzerland - Taiwan - Thailand - United Kingdom - U.S.A.