

To all our customers

Regarding the change of names mentioned in the document, such as Mitsubishi Electric and Mitsubishi XX, to Renesas Technology Corp.

The semiconductor operations of Hitachi and Mitsubishi Electric were transferred to Renesas Technology Corporation on April 1st 2003. These operations include microcomputer, logic, analog and discrete devices, and memory chips other than DRAMs (flash memory, SRAMs etc.) Accordingly, although Mitsubishi Electric, Mitsubishi Electric Corporation, Mitsubishi Semiconductors, and other Mitsubishi brand names are mentioned in the document, these names have in fact all been changed to Renesas Technology Corp. Thank you for your understanding. Except for our corporate trademark, logo and corporate statement, no changes whatsoever have been made to the contents of the document, and these changes do not constitute any alteration to the contents of the document itself.

Note : Mitsubishi Electric will continue the business operations of high frequency & optical devices and power devices.

Renesas Technology Corp.
Customer Support Dept.
April 1, 2003

M37151M6/M8/MA/MC/MF-XXXFP, M37151EFP

SINGLE-CHIP 8-BIT CMOS MICROCOMPUTER with CLOSED CAPTION DECODER
and ON-SCREEN DISPLAY CONTROLLER

1. DESCRIPTION

The M37151M6/M8/MA/MC/MF-XXXFP and M37151EFP are single-chip microcomputers designed with CMOS silicon gate technology. They have an OSD, data slicer, and I²C-BUS interface, making them perfect for TV channel selection systems with a closed caption decoder. The M37151EFP has a built-in PROM that can be written electrically.

2. FEATURES

- Number of basic instructions 71
- Memory size
 - ROM 24K bytes
(M37151M6-XXXFP)
 - 32K bytes
(M37151M8-XXXFP)
 - 40K bytes
(M37151MA-XXXFP)
 - 48K bytes
(M37151MC-XXXFP)
 - 60K bytes
(M37151MF-XXXFP, M37151EFP)
 - RAM 1024 bytes
(M37151M6-XXXFP)
 - 1152 bytes
(M37151M8-XXXFP)
 - 1472 bytes
(M37151MA-XXXFP, M37151MC-XXXFP)
 - 2048 bytes
(M37151MF-XXXFP, M37151EFP)

(*ROM correction memory included)
- Minimum instruction execution time
..... 0.5 μs (Min.)(at 8 MHz)
- Power source voltage 5 V ± 10 %
- Subroutine nesting 128 levels (Max.)
- Interrupts 17 types, 16 vectors
- 8-bit timers 6
- Programmable I/O ports (Ports P0, P1, P2, P30, P31) 25
- Serial I/O 8-bit X 1 channel
- Multi-master I²C-BUS interface 1 (3 systems)
- A-D comparator (7-bit resolution) 8 channels
- PWM output circuit 8-bit X 5
- Power dissipation
 - High-speed mode 165 mW
(at Vcc = 5.5V, Oscillation frequency 8 MHz, OSD on, and Data slicer on)
 - Low-speed mode 0.33 mW
(at Vcc = 5.5V, 32 kHz oscillation frequency)
- Closed caption data slicer
- ROM correction function 2 vectors
- OSD function
 - Display characters 32 characters X 2 lines

(It is possible to display 3 lines or more by software)

- Kinds of characters 254 kinds
(coloring unit) (per character unit)
- Character display area CC mode: 16 X 26 dots
OSD mode: 16 X 20 dots
- Kinds of character sizes CC mode: 1 kind
OSD mode: 8 kinds
- Kinds of character colors 8 colors (R, G, B)
- Coloring unit character, character background, raster
- Display position
 - Horizontal: 128 levels
 - Vertical: 512 levels
- Attribute
 - CC mode: smooth italic, underline, flash, automatic solid space
 - OSD mode: border
- Smooth roll-up
- Window function

3. APPLICATION

TV with closed caption decoder

M37151M6/M8/MA/MC/MF-XXXFP, M37151EFP

SINGLE-CHIP 8-BIT CMOS MICROCOMPUTER with CLOSED CAPTION DECODER
and ON-SCREEN DISPLAY CONTROLLER

TABLE OF CONTENTS

1. DESCRIPTION	1	14. MULTI-MASTER I ² C-BUS BUS LINE CHARACTERISTICS	102
2. FEATURES	1	15. PROM PROGRAMMING METHOD	103
3. APPLICATION	1	16. DATA REQUIRED FOR MASK ORDERS	103
4. PIN CONFIGURATION	3	17. ONE TIME PROM VERSION M37151EFP MARKING	104
5. FUNCTIONAL BLOCK DIAGRAM	4	18. APPENDIX	105
6. PERFORMANCE OVERVIEW	5	19. PACKAGE OUTLINE	136
7. PIN DESCRIPTION	7		
8. FUNCTIONAL DESCRIPTION	11		
8.1 CENTRAL PROCESSING UNIT (CPU)	11		
8.2 MEMORY	12		
8.3 INTERRUPTS	17		
8.4 TIMERS	22		
8.5 SERIAL I/O	26		
8.6 MULTI-MASTER I ² C-BUS INTERFACE	29		
8.7 PWM OUTPUT FUNCTION	42		
8.8 A-D COMPARATOR	46		
8.9 ROM CORRECTION FUNCTION	48		
8.10 DATA SLICER	49		
8.11 OSD FUNCTIONS	60		
8.11.1 Display Position	65		
8.11.2 Dot Size	69		
8.11.3 Clock for OSD	70		
8.11.4 Field Determination Display	71		
8.11.5 Memory for OSD	73		
8.11.6 Character color	77		
8.11.7 Character background color	77		
8.11.8 OUT signals	78		
8.11.9 Attribute	79		
8.11.10 Multiline Display	84		
8.11.11 Automatic Solid Space Function	85		
8.11.12 Window Function	86		
8.11.13 OSD Output Pin Control	88		
8.11.14 Raster Coloring Function	89		
8.12 SOFTWARE RUNAWAY DETECT FUNCTION	91		
8.13 RESET CIRCUIT	92		
8.14 CLOCK GENERATING CIRCUIT	93		
8.15 OSD OSCILLATION CIRCUIT	97		
8.16 AUTO-CLEAR CIRCUIT	98		
8.17 ADDRESSING MODE	98		
8.18 MACHINE INSTRUCTIONS	98		
9. PROGRAMMING NOTES	98		
10. ABSOLUTE MAXIMUM RATINGS	99		
11. RECOMMENDED OPERATING CONDITIONS	99		
12. ELECTRIC CHARACTERISTICS	100		
13. A-D CONVERTER CHARACTERISTICS	102		

M37151M6/M8/MA/MC/MF-XXXFP, M37151EFFP

SINGLE-CHIP 8-BIT CMOS MICROCOMPUTER with CLOSED CAPTION DECODER
and ON-SCREEN DISPLAY CONTROLLER

4. PIN CONFIGURATION

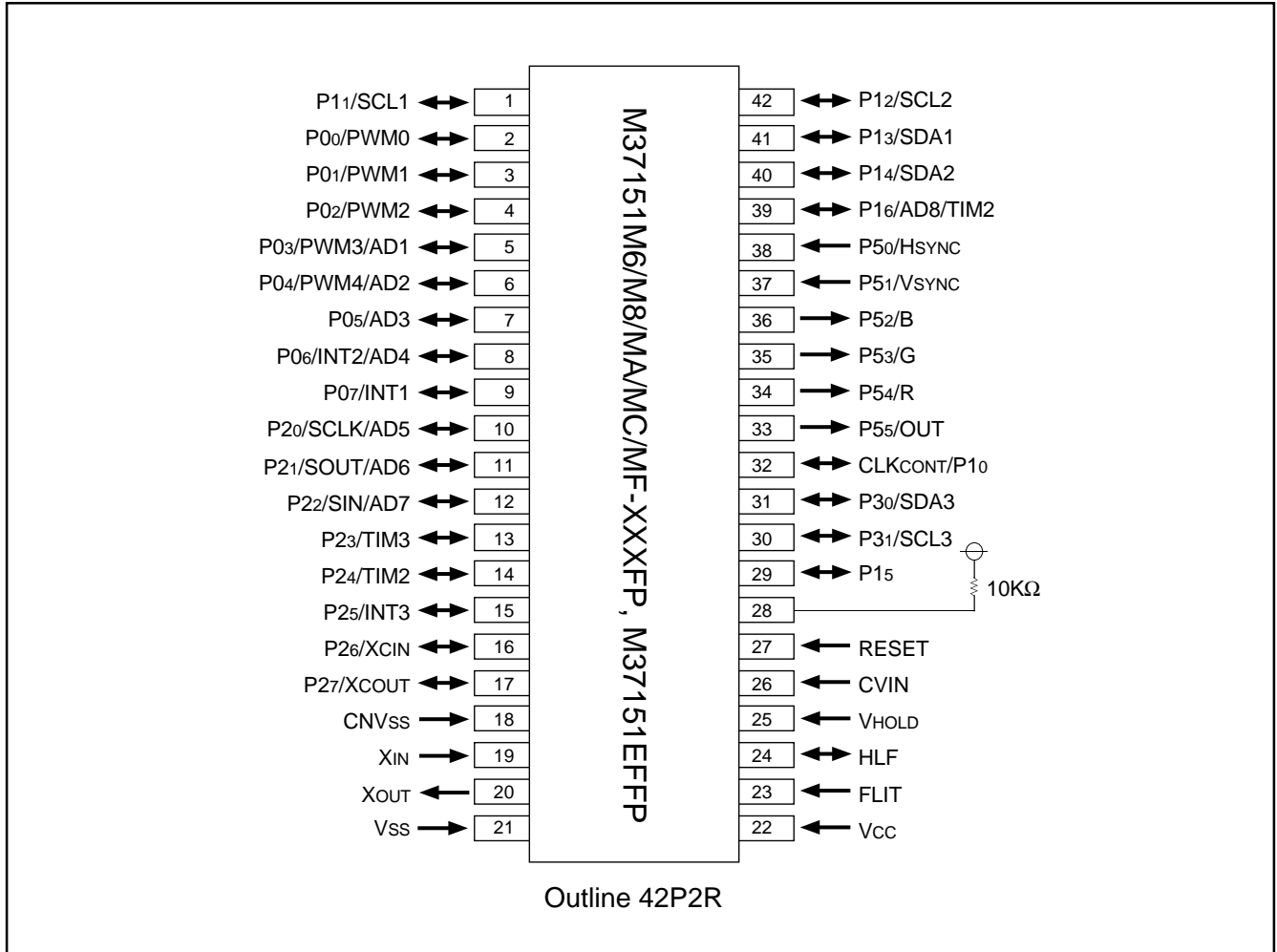

Fig. 4.1 Pin Configuration (Top View)

M37151M6/M8/MA/MC/MF-XXXFP, M37151EFP

SINGLE-CHIP 8-BIT CMOS MICROCOMPUTER with CLOSED CAPTION DECODER and ON-SCREEN DISPLAY CONTROLLER

5. FUNCTIONAL BLOCK DIAGRAM

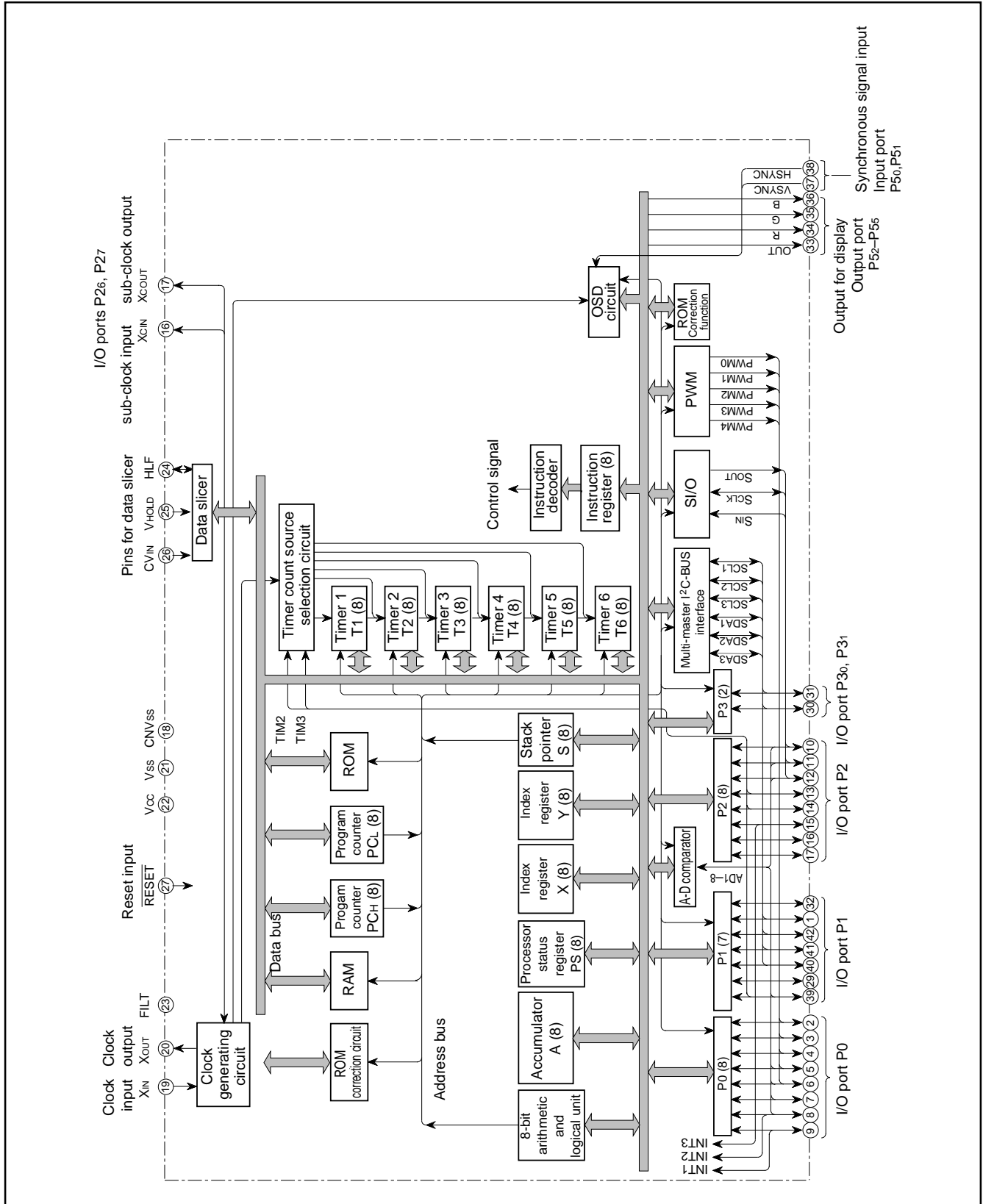

Fig. 5.1 Functional Block Diagram of M37151

M37151M6/M8/MA/MC/MF-XXXFP, M37151EFFP

SINGLE-CHIP 8-BIT CMOS MICROCOMPUTER with CLOSED CAPTION DECODER
and ON-SCREEN DISPLAY CONTROLLER

6. PERFORMANCE OVERVIEW

Table 6.1 Performance Overview

Parameter			Functions
Number of basic instructions			71
Instruction execution time			0.5 ms (the minimum instruction execution time, at 8 MHz oscillation frequency)
Clock frequency			8 MHz (maximum)
Memory size	ROM	M37151M6-XXXFP	24K bytes
		M37151M8-XXXFP	32K bytes
		M37151MA-XXXFP	40K bytes
		M37151MC-XXXFP	48K bytes
		M37151MF-XXXFP, M37151EFFP	60K bytes
	RAM	M37151M6-XXXFP	1024 bytes (ROM correction memory included)
		M37151M8-XXXFP	1152 bytes (ROM correction memory included)
		M37151MA-XXXFP, M37151MC-XXXFP	1472 bytes (ROM correction memory included)
M37151MF-XXXFP, M37151EFFP		2048 bytes (ROM correction memory included)	
Input/Output ports	P0	I/O	8-bit X 1 (N-channel open-drain output structure, can be used as PWM output pins, INT input pins, A-D input pin)
	P10–P16	I/O	7-bit X 1 (CMOS input/output structure, however, N-channel open-drain output structure, when P11–P14 are used as multi-master I ² C-BUS interface, can be used as A-D input pins, timer external clock input pins, multi-master I ² C-BUS interface)
	P20–P27	I/O	8-bit X 1 (P2 is CMOS input/output structure, however, N-channel open-drain output structure when P20 and 21 are used as serial output, can be used as serial input/output pins, timer external clock input pins, A-D input pins, INT input pin, sub-clock input/output pins)
	P30, P31	I/O	2-bit X 1 (CMOS input/output structure, however, N-channel open-drain output structure, when used as multi-master I ² C-BUS interface, can be used as multi-master I ² C-BUS interface.)
	P50, P51	Input	2-bit X 1 (can be used as OSD input pins)
	P52–P55	Output	4-bit X 1 (CMOS output structures, can be used as OSD output pins)
Serial I/O			8-bit X 1
Multi-master I ² C-BUS interface			One (Three lines)
A-D comparator			8 channels (7-bit resolution)
PWM output circuit			8-bit X 5
Timers			8-bit X 6
ROM correction function			2 vectors
Subroutine nesting			128 levels (maximum)
Interrupt			<17 types> INT external interrupt X 3, Internal timer interrupt X 6, Serial I/O interrupt X 1, OSD interrupt X 1, Multi-master I ² C-BUS interface interrupt X 1, Data slicer interrupt X 1, f(XIN)/4096 interrupt X 1, VSYNC interrupt X 1, BRK instruction interrupt X 1, reset X 1
Clock generating circuit			2 built-in circuits (externally connected to XCIN/OUT is a ceramic resonator or a quartz-crystal oscillator)
Data slicer			Built-in

M37151M6/M8/MA/MC/MF-XXXFP, M37151EFP

SINGLE-CHIP 8-BIT CMOS MICROCOMPUTER with CLOSED CAPTION DECODER
and ON-SCREEN DISPLAY CONTROLLER

Table 6.2 Performance Overview (Continued)

Parameter				Functions
OSD function	Number of display characters		32 characters X 2 lines	
	Dot structure		CC mode: 16 X 26 dots (character display area : 16 X 20 dots) OSD mode: 16 X 20 dots	
	Kinds of characters		254 kinds	
	Kinds of character sizes 1 screen : 8		CC mode: 1 kinds OSD mode: 8 kinds	
	Character font coloring		1 screen: 8 kinds (per character unit)	
	Display position		Horizontal: 128 levels, Vertical: 512 levels	
Power source voltage				5V ± 10%
Power dissipation	In high-speed mode	OSD ON	Data slicer ON	165 mW typ. (at oscillation frequency f(XIN) = 8 MHz, fOSC = 26 MHz)
		OSD OFF	Data slicer OFF	82.5 mW typ. (at oscillation frequency f(XIN) = 8 MHz)
	In low-speed mode	OSD OFF	Data slicer OFF	0.33 mW typ. (at oscillation frequency f(XCIN) = 32 kHz, f(XIN) = stop)
		In stop mode		0.055 mW (maximum)
Operating temperature range				-10 °C to 70 °C
Device structure				CMOS silicon gate process
Package				42-pin plastic molded SSOP

M37151M6/M8/MA/MC/MF-XXXFP, M37151EFFP

SINGLE-CHIP 8-BIT CMOS MICROCOMPUTER with CLOSED CAPTION DECODER
and ON-SCREEN DISPLAY CONTROLLER

7. PIN DESCRIPTION

Table 7.1 PIN DESCRIPTION

Pin	Name	Input/ Output	Functions
Vcc, Vss	Power source		Apply voltage of 5 V \pm 10 % to (typical) Vcc, and 0 V to Vss.
CNVss	CNVss		This is connected to Vss.
RESET	Reset input	Input	To enter the reset state, the reset input pin must be kept at a LOW for 2 ms or more (under normal Vcc conditions). If more time is needed for the quartz-crystal oscillator to stabilize, this LOW condition should be maintained for the required time.
XIN	Clock input	Input	This is the input pin for the main clock generating circuit. Built-in clock generation circuit, when set
XOUT	Clock output	Output	to oscillation frequency, connect ceramic resonator or crystal frequency between XIN and XOUT. When use external clock input, connect clock oscillation source to XIN pin, and open XOUT pin.
P00/PWM0– P02/PWM2, P03/PWM3/AD1, P04/PWM4/AD2, P05/AD3, P06/INT2/AD4, P07/INT1	I/O port P0 PWM output External interrupt input Analog input	I/O Output Input Input	Port P0 is an 8-bit I/O port with a direction register allowing each I/O bit to be individually programmed as input or output. At reset, this port is set to input mode. The output structure is N-channel open-drain output. (See note) Output Pins P00 to P04 are also used as PWM output pins PWM0 to PWM4, respectively. The output structure is N-channel open-drain output. Pins P06 and P07 are also used as INT external interrupt input pins INT2 and INT1 respectively. Pins P03, P04, P05 and P06 are also used as analog input pins AD1, AD2, AD3 and AD4, respectively.
P10/CLK CONT, P11/SCL1, P12/SCL2, P13/SDA1, P14/SDA2, P15, P16/AD8/TIM2	I/O port P1 Multi-master I ² C-BUS interface Clock control External clock input for timer Analog input	I/O I/O Output Input Input	Port P1 is a 7-bit I/O port and has basically the same functions as port P0. The output structure is CMOS output. (See note) Pins P11–P14 are used as SCL1, SCL2, SDA1 and SDA2 respectively, when multi-master I ² C-BUS interface is used. The output structure is N-channel open-drain output. P10 pin is also used as Clock control output CLK CONT. The output structure is CMOS output. P16 pin is also used as timer external clock input pin TIM2. P16 pin is also used as analog input pin AD8.
P20/SCLK/AD5, P21/SOUT/AD6, P22/SIN/AD7, P23/TIM3, P24/TIM2, P25/INT3, P26/XCIN, P27/XCOUT	I/O port P2 Serial I/O synchronous clock input/output port Serial I/O data output Serial I/O data input External clock input for timer Analog input Sub-clock input Sub-clock output External interrupt input	I/O I/O Output Input Input Input Output Input	Port P2 is an 8-bit I/O port and has basically the same functions as port P0. The output structure is CMOS output. (See note) P20 pin is also used as serial I/O synchronous clock input/output pin SCLK. The output structure is N-channel open-drain output. P21 pin is also used as serial I/O data output pin SOUT. The output structure is open-drain output. P22 pin is also used as serial I/O data input pin SIN. Pins P23 and P24 are also used as timer external clock input pins TIM3 and TIM2 respectively. Pins P20–P22 are also used as analog input pins AD5, AD6 and AD7 respectively. P26 pin is also used as sub-clock input pin XCIN. P27 pin is also used as sub-clock output pin XCOUT. The output structure is CMOS output. P25 pin is also used as INT external interrupt input pin INT3.
P30/SDA3 P31/SCL3	I/O port P3 Multi-master I ² C-BUS Interface	I/O I/O	Port P30,P31 is an 2-bit I/O port and has basically the same functions as port P0. The output structure is CMOS output. (See note) Pins P30,P31 are used as SDA3,SCL3 respectively, when multi-master I ² C-BUS interface is used. The output structure is N-channel open-drain output.

M37151M6/M8/MA/MC/MF-XXXFP, M37151EFP

SINGLE-CHIP 8-BIT CMOS MICROCOMPUTER with CLOSED CAPTION DECODER
and ON-SCREEN DISPLAY CONTROLLER

Table 7.2 PIN DESCRIPTION (continued)

Pin	Name	Input/ Output	Functions
P50/HSYNC	Input P5	Input	Port P5 is a 2-bit input port.
P51/VSYNC	Horizontal synchronous signal	Input	The P5 ₀ pin is also used as a horizontal synchronous signal input Hsync for OSD.
	Vertical synchronous signal	Input	The P5 ₁ pin is also used as a vertical synchronous signal input Vsync for OSD.
P52/B, P53/G, P54/R, P55/OUT	Output P5	output	Pins P5 ₂ –P5 ₅ are a 4-bit output port. The output structure is CMOS output.
	OSD output	output	Pins P5 ₂ –P5 ₅ are also used as OSD output pins R, G, B and OUT respectively. The output structure is CMOS output.
CVIN	I/O for data slicer	Input	Input the composite video signal through a capacitor.
VHOLD		Input	Connect a capacitor between VHOLD and Vss.
HLF		I/O	Connect a filter consisting of a capacitor and a resistor, between HLF and Vss.
FILT	Clock oscillation filter	Input	Connect a capacitor between FILT and Vss.

Notes : Port Pi (i = 0 to 3) has the port Pi direction register which can be used to program each bit for input ("0") or an output ("1"). The pins programmed as "1" in the direction register are output pins. When pins are programmed as "0," they are input pins. When pins are programmed as output pins, the output data are written into the port latch and then output. When data is read from the output pins, the data of the port latch, not the output pin level, is read. This allows a previously-output value to be read correctly even if the output LOW voltage has risen due to, for example, a directly-driven light emitting diode was directly driven. The input pins are in the floating state, so the values of the pins can be read. When data is written into the input pin, it is written only into the port latch, while the pin remains in the floating state.

* LED drive ports 4 (P24–P27)

M37151M6/M8/MA/MC/MF-XXXFP, M37151EFFP

SINGLE-CHIP 8-BIT CMOS MICROCOMPUTER with CLOSED CAPTION DECODER
and ON-SCREEN DISPLAY CONTROLLER

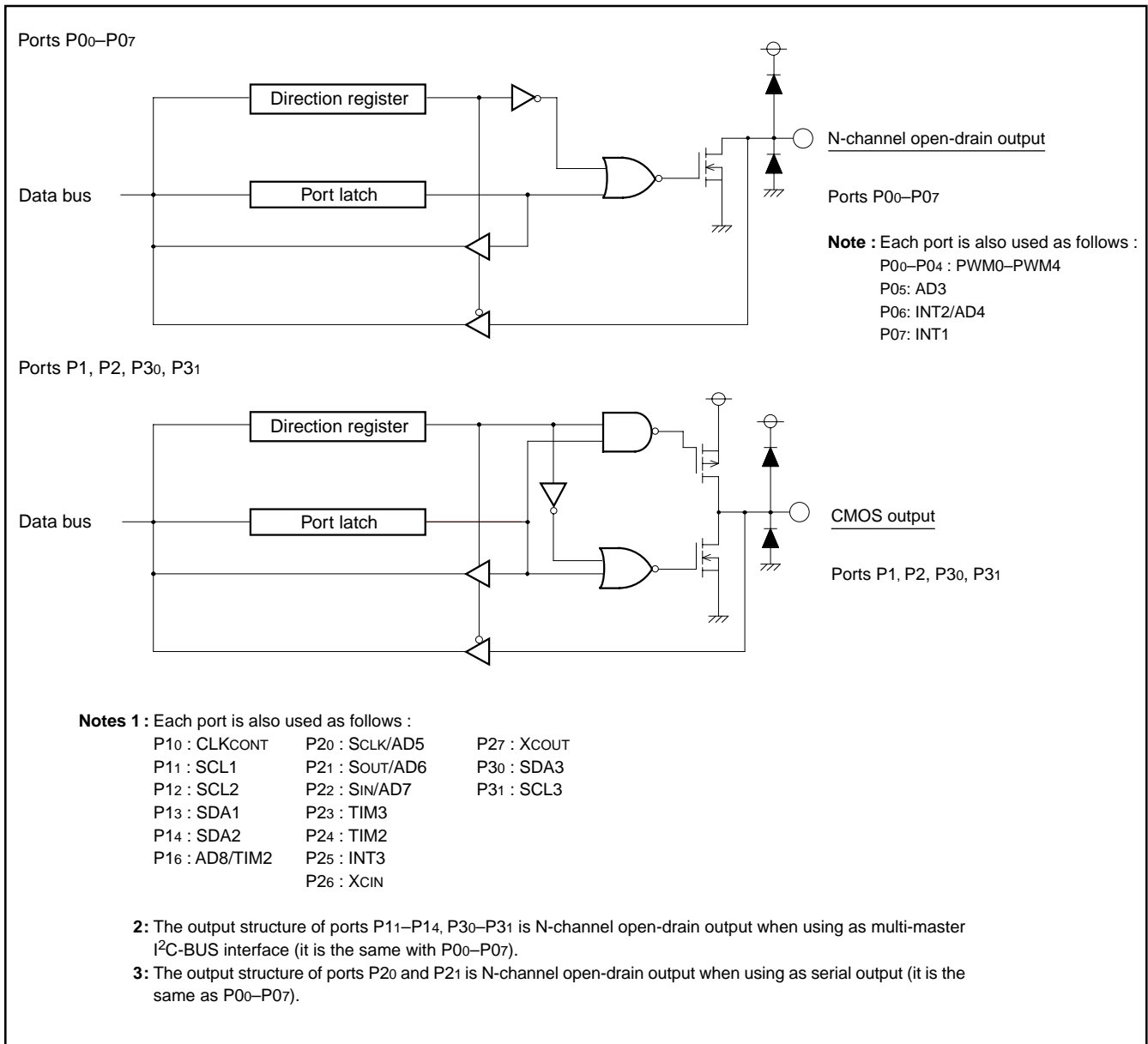

Fig. 7.1 I/O Pin Block Diagram (1)

M37151M6/M8/MA/MC/MF-XXXFP, M37151EFP

SINGLE-CHIP 8-BIT CMOS MICROCOMPUTER with CLOSED CAPTION DECODER
and ON-SCREEN DISPLAY CONTROLLER

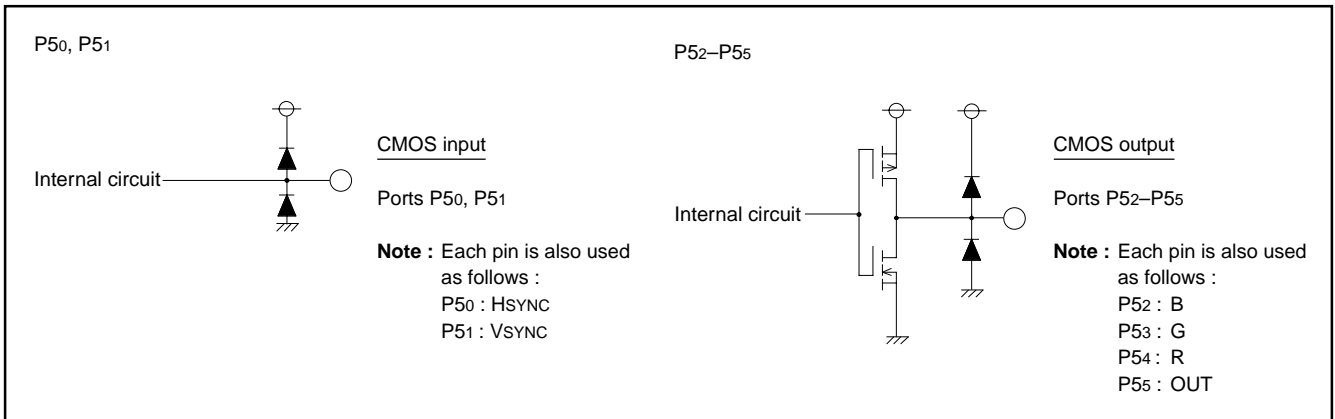

Fig. 7.2 I/O Pin Block Diagram (2)

M37151M6/M8/MA/MC/MF-XXXFP, M37151EFFP

SINGLE-CHIP 8-BIT CMOS MICROCOMPUTER with CLOSED CAPTION DECODER and ON-SCREEN DISPLAY CONTROLLER

8. FUNCTIONAL DESCRIPTION

8.1 CENTRAL PROCESSING UNIT (CPU)

This microcomputer uses the standard 740 Family instruction set. Refer to the table of 740 Family addressing modes and machine instructions or the SERIES 740 <Software> User's Manual for details on the instruction set.

Availability of 740 Family instructions is as follows:

The FST and SLW instructions cannot be used.

The MUL, DIV, WIT and STP instructions can be used.

8.1.1 CPU Mode Register

The CPU mode register includes the stack page selection bit and internal system clock selection bit. The CPU mode register is allocated at address 00FB16.

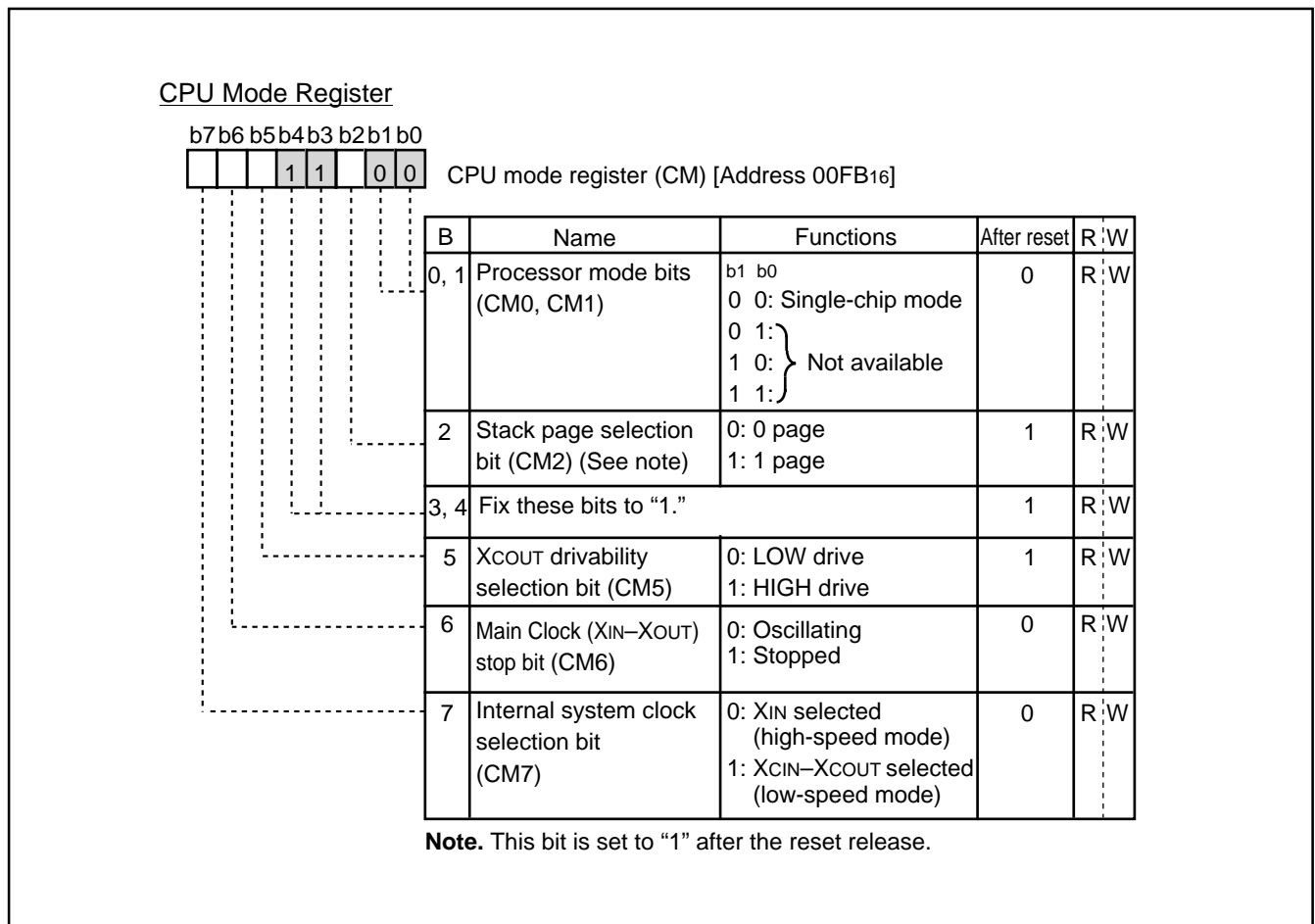

Fig. 8.1.1 CPU Mode Register

M37151M6/M8/MA/MC/MF-XXXFP, M37151EFP

SINGLE-CHIP 8-BIT CMOS MICROCOMPUTER with CLOSED CAPTION DECODER and ON-SCREEN DISPLAY CONTROLLER

8.2 MEMORY

8.2.1 Special Function Register (SFR) Area

The special function register (SFR) area in the zero page contains control registers such as I/O ports and timers.

8.2.2 RAM

RAM is used for data storage and for stack area of subroutine calls and interrupts.

8.2.3 ROM

ROM is used for storing user programs as well as the interrupt vector area.

8.2.4 OSD RAM

RAM for display is used for specifying the character codes and colors to display.

8.2.5 OSD ROM

ROM for display is used for storing character data.

8.2.6 Interrupt Vector Area

The interrupt vector area contains reset and interrupt vectors.

8.2.7 Zero Page

The zero page addressing mode can be used to specify memory and register addresses in the zero page area. Access to this area with only 2 bytes is possible in the zero page addressing mode.

8.2.8 Special Page

The special page addressing mode can be used to specify memory addresses in the special page area. Access to this area with only 2 bytes is possible in the special page addressing mode.

8.2.9 ROM Correction Memory (RAM)

This is used as the program area for ROM correction.

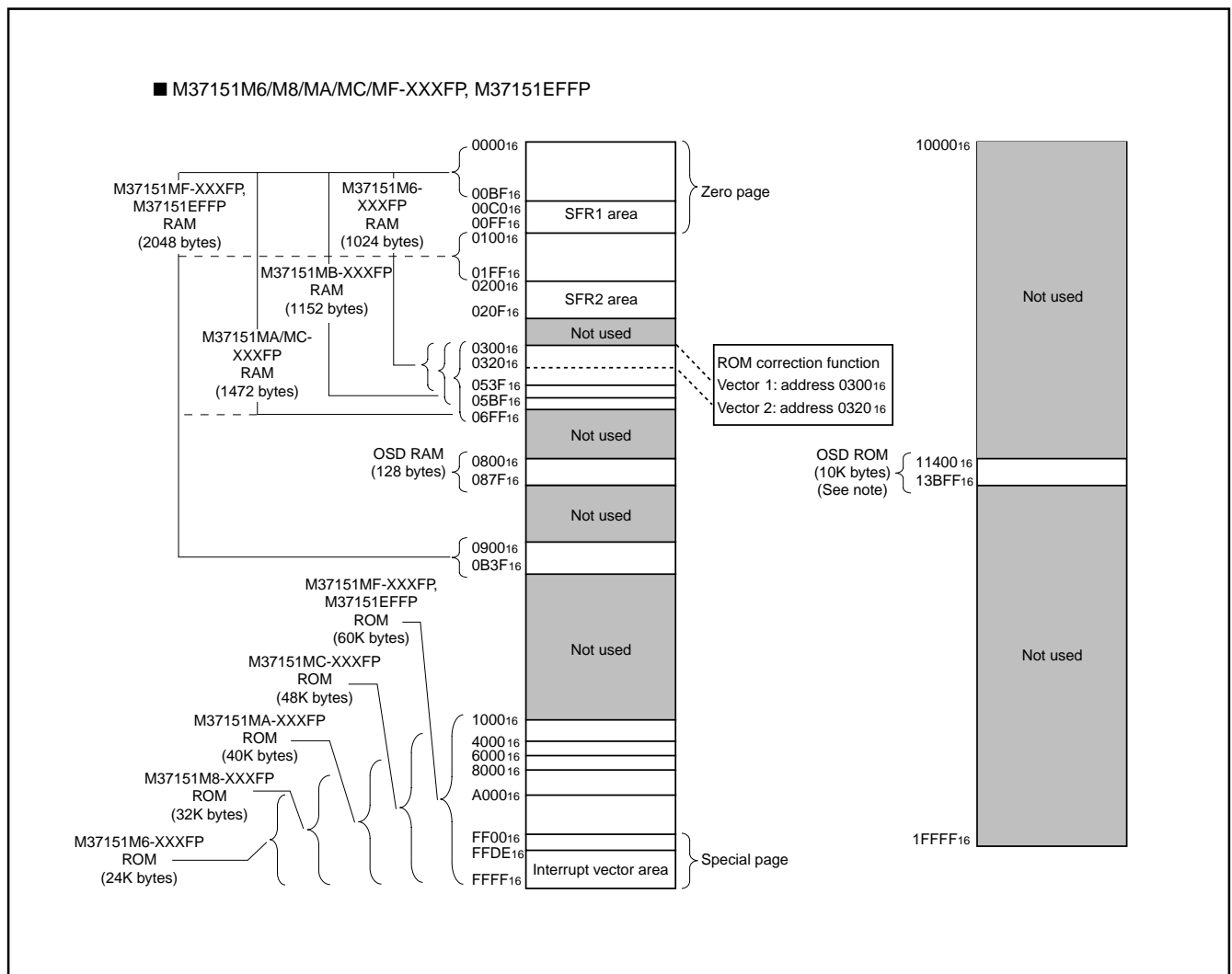

Fig. 8.2.1 Memory Map (M37151M6/M8/MA/MC/MF-XXXFP, M37151EFP)

M37151M6/M8/MA/MC/MF-XXXFP, M37151EFFP

SINGLE-CHIP 8-BIT CMOS MICROCOMPUTER with CLOSED CAPTION DECODER
and ON-SCREEN DISPLAY CONTROLLER

■ SFR1 Area (addresses C0₁₆ to DF₁₆)

<Bit allocation>

- : } Function bit
- Name : }
- : No function bit
- 0 : Fix this bit to 0
(do not write 1)
- 1 : Fix this bit to 1
(do not write 0)

<State immediately after reset>

- 0 : 0 immediately after reset
- 1 : 1 immediately after reset
- ? : Indeterminate immediately after reset

Address	Register	Bit allocation								State immediately after reset								
		b7						b0		b7							b0	
C0 ₁₆	Port P0(P0)																?	
C1 ₁₆	Port P0 direction register (D0)																00 ₁₆	
C2 ₁₆	Port P1(P1)	0								?	?	0	?	?	?	?	?	
C3 ₁₆	Port P1 direction register (D1)	0								0	0	1	0	0	0	0	1	
C4 ₁₆	Port P2(P2)																?	
C5 ₁₆	Port P2 direction register (D2)																00 ₁₆	
C6 ₁₆	Port P3(P3)						BSEL21	BSEL20	P31	P30	0	0	0	0	0	0	?	?
C7 ₁₆	Port P3 direction register (D3)	T2SC	T3SC				0	OUTS	P31D	P30D								00 ₁₆
C8 ₁₆		0	0	0	0	0	0	0	0	0								?
C9 ₁₆		0	0	1	1	1	1	1	1	1								?
CA ₁₆	Port P5(P5)	0	0						0	0								?
CB ₁₆	OSD port control register (PF)	1	0	PF5	PF4	PF3	PF2	0	0	0	0	?	0	0	0	0	0	0
CC ₁₆	Timer return set register (TMS)	TMS	1	1	0	0	0	0	0	0								00 ₁₆
CD ₁₆	Clock control register 1 (CC1)	0	0	0	0	0	0	0	0	CC10								00 ₁₆
CE ₁₆	Caption data register 3 (CD3)	CDL27	CDL26	CDL25	CDL24	CDL23	CDL22	CDL21	CDL20								?	
CF ₁₆	Caption data register 4 (CD4)	CDH27	CDH26	CDH25	CDH24	CDH23	CDH22	CDH21	CDH20								?	
D0 ₁₆	OSD control register (OC)	OC7	0	0	OC4	OC3	OC2	OC1	OC0								00 ₁₆	
D1 ₁₆	Horizontal position register (HP)		HP6	HP5	HP4	HP3	HP2	HP1	HP0								00 ₁₆	
D2 ₁₆	Block control register 1(BC1)	BC17	BC16	BC15	BC14	BC13	BC12	BC11	BC10								?	
D3 ₁₆	Block control register 2(BC2)	BC27	BC26	BC25	BC24	BC23	BC22	BC21	BC20								?	
D4 ₁₆	Vertical position register 1(VP1)	VP17	VP16	VP15	VP14	VP13	VP12	VP11	VP10								?	
D5 ₁₆	Vertical position register 2(VP2)	VP27	VP26	VP25	VP24	VP23	VP22	VP21	VP20								?	
D6 ₁₆	Window register 1(WN1)	WN17	WN16	WN15	WN14	WN13	WN12	WN11	WN10								?	
D7 ₁₆	Window register 2(WN2)	WN27	WN26	WN25	WN24	WN23	WN22	WN21	WN20								?	
D8 ₁₆	I/O polarity control register (PC)	0	PC6	PC5	0	PC3	PC2	PC1	PC0								40 ₁₆	
D9 ₁₆	Raster color register (RC)	RC7	0	0	0	RC3	RC2	RC1	RC0								00 ₁₆	
DA ₁₆																	?	
DB ₁₆	OSD control register 2(OC2)	0	0	0				0	OC21	OC20	0	0	0	?	0	0	0	0
DC ₁₆	Interrupt input polarity control register (RE)							INT3	INT2	INT1								00 ₁₆
DD ₁₆																		00 ₁₆
DE ₁₆																		00 ₁₆
DF ₁₆																		00 ₁₆

Fig. 8.2.2 Memory Map of Special Function Register 1 (SFR1) (1)

M37151M6/M8/MA/MC/MF-XXXFP, M37151EFP

SINGLE-CHIP 8-BIT CMOS MICROCOMPUTER with CLOSED CAPTION DECODER
and ON-SCREEN DISPLAY CONTROLLER

■ SFR1 Area (addresses E0₁₆ to FF₁₆)

<Bit allocation>

- : } Function bit
Name : }
- : No function bit
- 0 : Fix this bit to 0
(do not write 1)
- 1 : Fix this bit to 1
(do not write 0)

<State immediately after reset>

- 0 : 0 immediately after reset
- 1 : 1 immediately after reset
- ? : Indeterminate immediately after reset

Address	Register	Bit allocation								State immediately after reset							
		b7							b0	b7							b0
E0 ₁₆	Data slicer control register 1 (DSC1)	<input checked="" type="checkbox"/>	<input checked="" type="checkbox"/>	<input checked="" type="checkbox"/>	<input checked="" type="checkbox"/>	<input checked="" type="checkbox"/>	DSC12	DSC11	DSC10	0	0	0	0	0	0	0	0
E1 ₁₆	Data slicer control register 2 (DSC2)	<input checked="" type="checkbox"/>	<input checked="" type="checkbox"/>	<input checked="" type="checkbox"/>	<input checked="" type="checkbox"/>	<input checked="" type="checkbox"/>	DSC25	DSC24	DSC23	<input checked="" type="checkbox"/>	<input checked="" type="checkbox"/>	<input checked="" type="checkbox"/>	<input checked="" type="checkbox"/>	<input checked="" type="checkbox"/>	<input checked="" type="checkbox"/>	<input checked="" type="checkbox"/>	<input checked="" type="checkbox"/>
E2 ₁₆	Caption data register 1 (CD1)	CDL17	CDL16	CDL15	CDL14	CDL13	CDL12	CDL11	CDL10	0	0	0	0	0	0	0	0
E3 ₁₆	Caption data register 2 (CD2)	CDH17	CDH16	CDH15	CDH14	CDH13	CDH12	CDH11	CDH10	0	0	0	0	0	0	0	0
E4 ₁₆	Clock run-in detect register (CRD)	CRD7	CRD6	CRD5	CRD4	CRD3				0	0	0	0	0	0	0	0
E5 ₁₆	Data clock position register (DPS)	DPS7	DPS6	DPS5	DPS4	DPS3	<input checked="" type="checkbox"/>	<input checked="" type="checkbox"/>	<input checked="" type="checkbox"/>	0	1	0	0	0	0	0	0
E6 ₁₆	Caption position register (CPS)	CPS7	CPS6	CPS5	CPS4	CPS3	CPS2	CPS1	CPS0	0	0	?	0	0	0	0	0
E7 ₁₆	Data slicer test register 2									0	0	0	0	0	0	0	0
E8 ₁₆	Data slicer test register 1									0	0	0	0	0	0	0	0
E9 ₁₆	Synchronous signal counter register (HC)			HC5	HC4	HC3	HC2	HC1	HC0	0	0	0	0	0	0	0	0
EA ₁₆	Serial I/O register (SIO)									?	?	?	?	?	?	?	?
EB ₁₆	Serial I/O mode register (SM)	<input checked="" type="checkbox"/>	SM6	SM5	<input checked="" type="checkbox"/>	SM3	SM2	SM1	SM0	0	0	0	0	0	0	0	0
EC ₁₆	A-D control register 1 (AD1)				ADC14		ADC12	ADC11	ADC10	0	0	0	?	0	0	0	0
ED ₁₆	A-D control register 2 (AD2)		ADC26	ADC25	ADC24	ADC23	ADC22	ADC21	ADC20	0	0	0	0	0	0	0	0
EE ₁₆	Timer 5 (T5)									0	7	?	?	?	?	?	?
EF ₁₆	Timer 6 (T6)									0	7	?	?	?	?	?	?
F0 ₁₆	Timer 1 (T1)									0	7	?	?	?	?	?	?
F1 ₁₆	Timer 2 (T2)									0	7	?	?	?	?	?	?
F2 ₁₆	Timer 3 (T3)									0	7	?	?	?	?	?	?
F3 ₁₆	Timer 4 (T4)									0	7	?	?	?	?	?	?
F4 ₁₆	Timer mode register 1 (TM1)	TM17	TM16	TM15	TM14	TM13	TM12	TM11	TM10	0	0	0	0	0	0	0	0
F5 ₁₆	Timer mode register 2 (TM2)	TM27	TM26	TM25	TM24	TM23	TM22	TM21	TM20	0	0	0	0	0	0	0	0
F6 ₁₆	I ² C data shift register (S0)	D7	D6	D5	D4	D3	D2	D1	D0	?	?	?	?	?	?	?	?
F7 ₁₆	I ² C address register (S0D)	SAD6	SAD5	SAD4	SAD3	SAD2	SAD1	SAD0	RBW	0	0	0	0	0	0	0	0
F8 ₁₆	I ² C status register (S1)	MST	TRX	BB	PIN	AL	AAS	ADO	LRB	0	0	0	1	0	0	0	?
F9 ₁₆	I ² C control register (S1D)	BSEL1	BSEL0	¹⁰ BIT SAD	ALS	ESO	BC2	BC1	BC0	0	0	0	0	0	0	0	0
FA ₁₆	I ² C clock control register (S2)	ACK	ACK BIT	FAST MODE	CCR4	CCR3	CCR2	CCR1	CCR0	0	0	0	0	0	0	0	0
FB ₁₆	CPU mode register (CPUM)	CM7	CM6	CM5	<input checked="" type="checkbox"/>	<input checked="" type="checkbox"/>	CM2	<input checked="" type="checkbox"/>	<input checked="" type="checkbox"/>	3	C	?	?	?	?	?	?
FC ₁₆	Interrupt request register 1 (IREQ1)		IN3R	VSCR	OSDR	TM4R	TM3R	TM2R	TM1R	0	0	0	0	0	0	0	0
FD ₁₆	Interrupt request register 2 (IREQ2)	<input checked="" type="checkbox"/>	TM56R	IICR	IN2R	CKR	S1R	DSR	IN1R	0	0	0	0	0	0	0	0
FE ₁₆	Interrupt control register 1 (ICON1)		IN3E	VSCE	OSDE	TM4E	TM3E	TM2E	TM1E	0	0	0	0	0	0	0	0
FF ₁₆	Interrupt control register 2 (ICON2)	TM56C	TM56E	IICE	IN2E	CKE	S1E	DSE	IN1E	0	0	0	0	0	0	0	0

Fig. 8.2.3 Memory Map of Special Function Register 1 (SFR1) (2)

M37151M6/M8/MA/MC/MF-XXXFP, M37151EFFP

SINGLE-CHIP 8-BIT CMOS MICROCOMPUTER with CLOSED CAPTION DECODER
and ON-SCREEN DISPLAY CONTROLLER

■SFR2 Area (addresses 200₁₆ to 20F₁₆)

<Bit allocation>

: } Function bit
Name : }

: No function bit

0 : Fix this bit to 0
(do not write 1)

1 : Fix this bit to 1
(do not write 0)

<State immediately after reset>

0 : 0 immediately after reset

1 : 1 immediately after reset

? : Indeterminate immediately
after reset

Address	Register	Bit allocation								State immediately after reset								
		b7						b0		b7						b0		
200 ₁₆	PWM0 register (PWM0)									?								
201 ₁₆	PWM1 register (PWM1)									?								
202 ₁₆	PWM2 register (PWM2)									?								
203 ₁₆	PWM3 register (PWM3)									?								
204 ₁₆	PWM4 register (PWM4)									?								
205 ₁₆										?								
206 ₁₆		00 ₁₆								?								
207 ₁₆		00 ₁₆								?								
208 ₁₆	PWM mode register 1 (PM1)						PM13			?	?	?	?	0	?	?	0	
209 ₁₆	PWM mode register 2 (PM2)	0	0	0		PM24	PM23	PM22	PM21	PM20	00 ₁₆							
20A ₁₆	ROM correction address 1 (high-order)									00 ₁₆								
20B ₁₆	ROM correction address 1 (low-order)									00 ₁₆								
20C ₁₆	ROM correction address 2 (high-order)									00 ₁₆								
20D ₁₆	ROM correction address 2 (low-order)									00 ₁₆								
20E ₁₆	ROM correction enable register (RCR)								RC1	RC0	00 ₁₆							
20F ₁₆										?								
210	Clock frequency set register (CFS)									0	0	0	0	0	1	1	1	0
211	Clock control register 2(CC2)	0	1	0	0	0	0	1	0	0	00 ₁₆							
212	Clock control register 3(CC3)	CC37	0	CC35	0	0	0	0	0	0	00 ₁₆							

Fig. 8.2.4 Memory Map of Special Function Register 2 (SFR2)

M37151M6/M8/MA/MC/MF-XXXFP, M37151EFP

SINGLE-CHIP 8-BIT CMOS MICROCOMPUTER with CLOSED CAPTION DECODER
and ON-SCREEN DISPLAY CONTROLLER

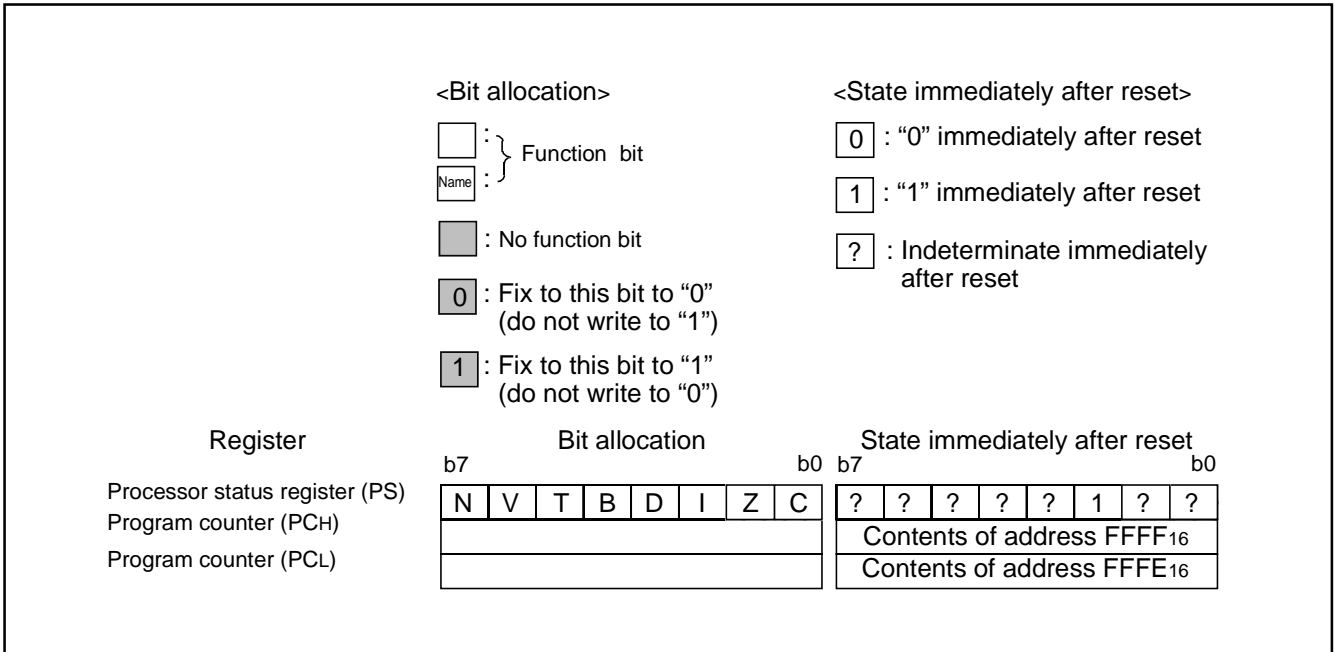

Fig. 8.2.5 Internal State of Processor Status Register and Program Counter at Reset

M37151M6/M8/MA/MC/MF-XXXFP, M37151EFFP

SINGLE-CHIP 8-BIT CMOS MICROCOMPUTER with CLOSED CAPTION DECODER
and ON-SCREEN DISPLAY CONTROLLER

8.3 INTERRUPTS

Interrupts can be caused by 17 different sources consisting of 4 external, 11 internal, 1 software, and reset. Interrupts are vectored interrupts with priorities as shown in Table 8.3.1. Reset is also included in the table because its operation is similar to an interrupt.

When an interrupt is accepted,

- ① The contents of the program counter and processor status register are automatically stored into the stack.
- ② The interrupt disable flag I is set to "1" and the corresponding interrupt request bit is set to "0."
- ③ The jump destination address stored in the vector address enters the program counter.

Other interrupts are disabled when the interrupt disable flag is set to "1."

All interrupts except the BRK instruction interrupt have an interrupt request bit and an interrupt enable bit. The interrupt request bits are in interrupt request registers 1 and 2 and the interrupt enable bits are in interrupt control registers 1 and 2. Figures 8.3.2 to 8.3.6 show the interrupt-related registers.

Interrupts other than the BRK instruction interrupt and reset are accepted when the interrupt enable bit is "1," interrupt request bit is "1," and the interrupt disable flag is "0." The interrupt request bit can be set to "0" by a program, but not set to "1." The interrupt enable bit can be set to "0" and "1" by a program.

Reset is treated as a non-maskable interrupt with the highest priority.

Figure 8.3.1 shows interrupt control.

8.3.1 Interrupt Causes

(1) VSYNC, OSD interrupts

The VSYNC interrupt is an interrupt request synchronized with the vertical sync signal.

The OSD interrupt occurs after character block display to the CRT is completed.

(2) INT1 to INT3 external interrupts

The INT1 to INT3 interrupts are external interrupt inputs, the system detects that the level of a pin changes from LOW to HIGH or from HIGH to LOW, and generates an interrupt request. The input active edge can be selected by bits 3 to 5 of the interrupt input polarity register (address 00DC16) : when this bit is "0," a change from LOW to HIGH is detected; when it is "1," a change from HIGH to LOW is detected. Note that both bits are cleared to "0" at reset.

(3) Timers 1 to 4 interrupts

An interrupt is generated by an overflow of timers 1 to 4.

Table 8.3.1 Interrupt Vector Addresses and Priority

Priority	Interrupt Source	Vector Addresses	Remarks
1	Reset	FFFF ₁₆ , FFFE ₁₆	Non-maskable
2	OSD interrupt	FFFD ₁₆ , FFFC ₁₆	
3	INT1 external interrupt	FFFB ₁₆ , FFFA ₁₆	Active edge selectable
4	Data slicer interrupt	FFF9 ₁₆ , FFF8 ₁₆	
5	Serial I/O interrupt	FFF7 ₁₆ , FFF6 ₁₆	
6	Timer 4 interrupt	FFF5 ₁₆ , FFF4 ₁₆	
7	f(XIN)/4096 interrupt	FFF3 ₁₆ , FFF2 ₁₆	
8	VSYNC interrupt	FFF1 ₁₆ , FFF0 ₁₆	
9	Timer 3 interrupt	FFEF ₁₆ , FFEE ₁₆	
10	Timer 2 interrupt	FFED ₁₆ , FFEC ₁₆	
11	Timer 1 interrupt	FFEB ₁₆ , FFEA ₁₆	
12	INT3 external interrupt	FFE9 ₁₆ , FFE8 ₁₆	Active edge selectable
13	INT2 external interrupt	FFE7 ₁₆ , FFE6 ₁₆	Active edge selectable
14	Multi-master I ² C-BUS interface interrupt	FFE5 ₁₆ , FFE4 ₁₆	
15	Timer 5 • 6 interrupt	FFE3 ₁₆ , FFE2 ₁₆	Source switch by software (see note)
16	BRK instruction interrupt	FFDF ₁₆ , FFDE ₁₆	Non-maskable

Note: Switching a source during a program causes an unnecessary interrupt. Therefore, set a source at initializing of program.

M37151M6/M8/MA/MC/MF-XXXFP, M37151EFP

SINGLE-CHIP 8-BIT CMOS MICROCOMPUTER with CLOSED CAPTION DECODER
and ON-SCREEN DISPLAY CONTROLLER

(4) Serial I/O interrupt

This is an interrupt request from the clock synchronous serial I/O function.

(5) f(XIN)/4096 interrupt

The f(XIN)/4096 interrupt occurs regularly with a f(XIN)/4096 period. Set bit 0 of the PWM mode register 1 to "0."

(6) Data slicer interrupt

An interrupt occurs when slicing data is completed.

(7) Multi-master I²C-BUS interface interrupt

This is an interrupt request related to the multi-master I²C-BUS interface.

(8) Timer 5 • 6 interrupt

An interrupt is generated by an overflow of timer 5 or 6. Their priorities are same, and can be switched by software.

(9) BRK instruction interrupt

This software interrupt has the least significant priority. It does not have a corresponding interrupt enable bit, and it is not affected by the interrupt disable flag I (non-maskable).

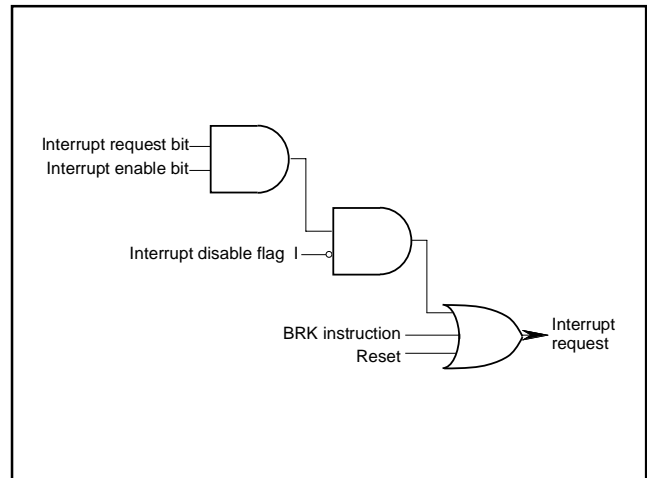

Fig. 8.3.1 Interrupt Control

M37151M6/M8/MA/MC/MF-XXXFP, M37151EFFP

SINGLE-CHIP 8-BIT CMOS MICROCOMPUTER with CLOSED CAPTION DECODER
and ON-SCREEN DISPLAY CONTROLLER

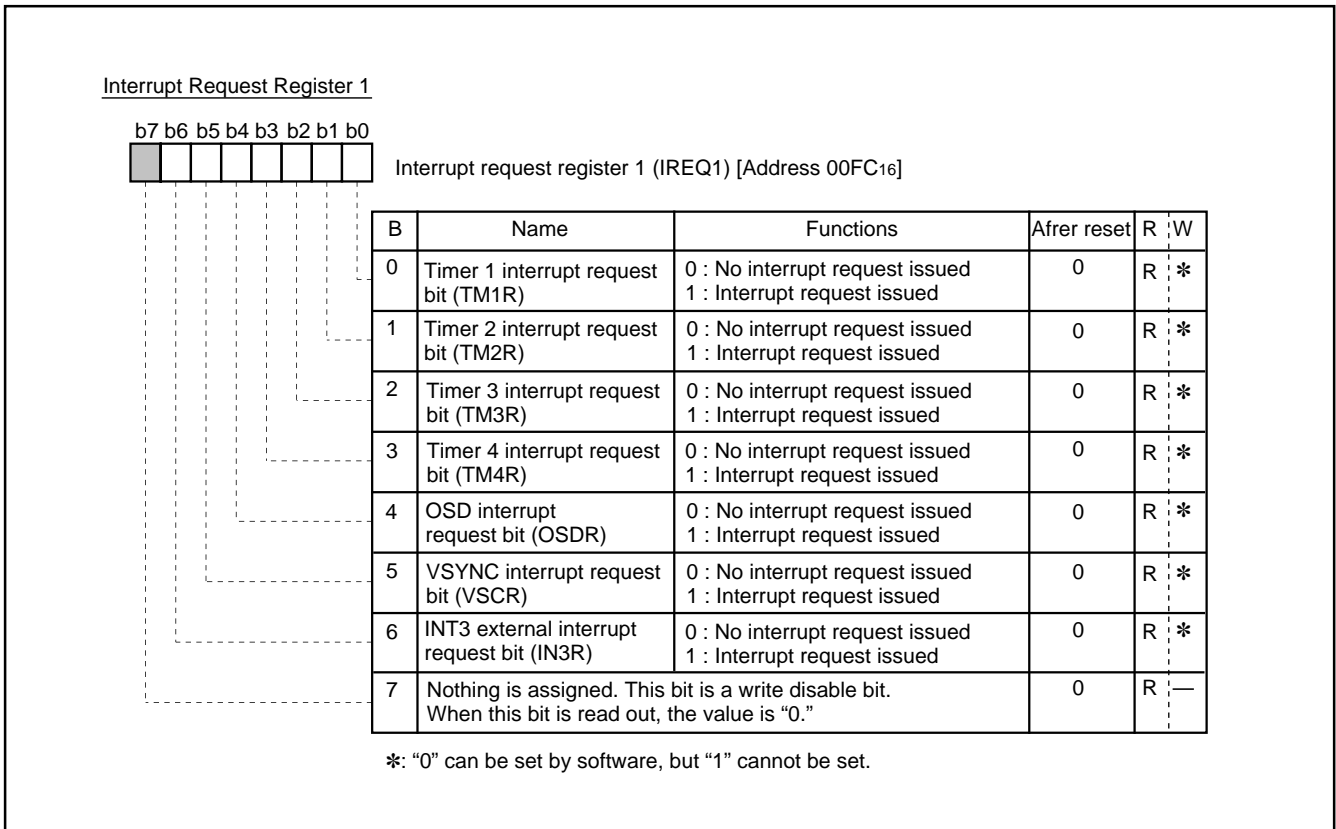

Fig. 8.3.2 Interrupt Request Register 1

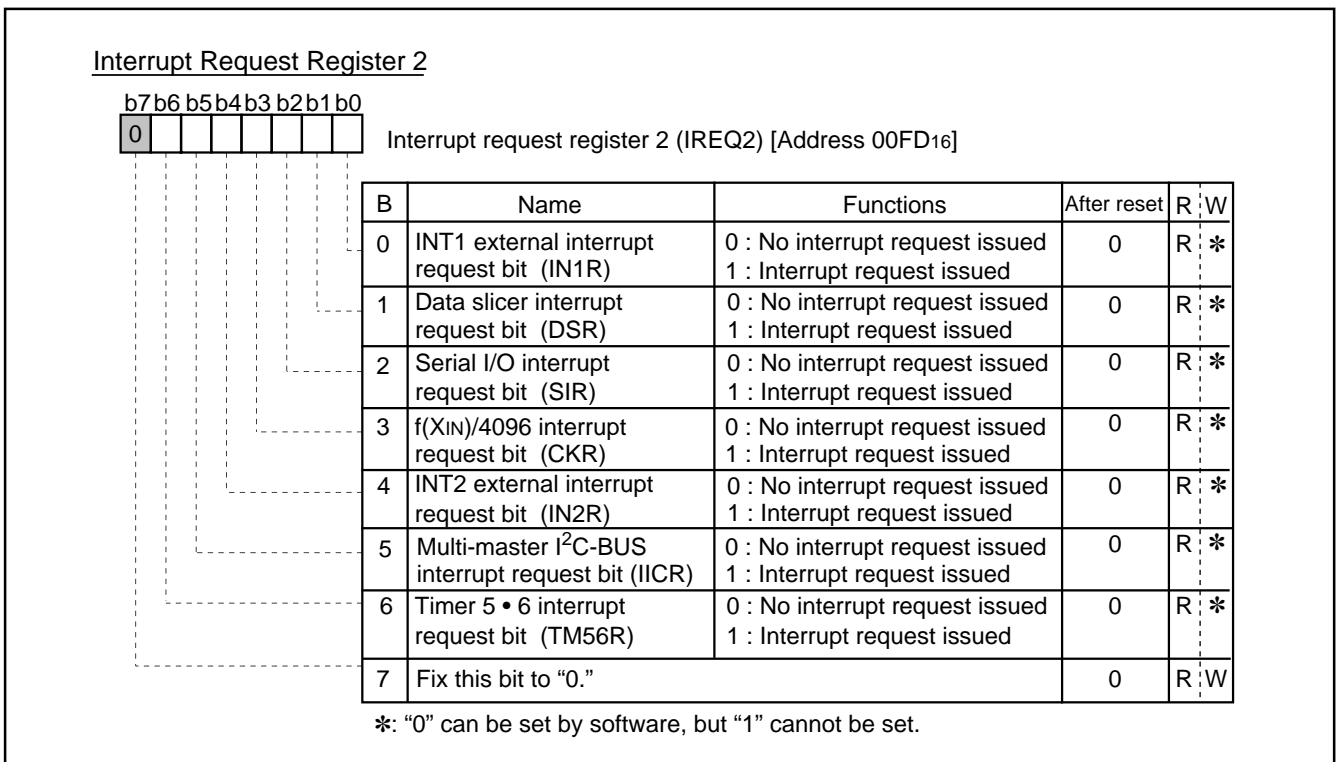

Fig. 8.3.3 Interrupt Request Register 2

M37151M6/M8/MA/MC/MF-XXXFP, M37151EFP

SINGLE-CHIP 8-BIT CMOS MICROCOMPUTER with CLOSED CAPTION DECODER
and ON-SCREEN DISPLAY CONTROLLER

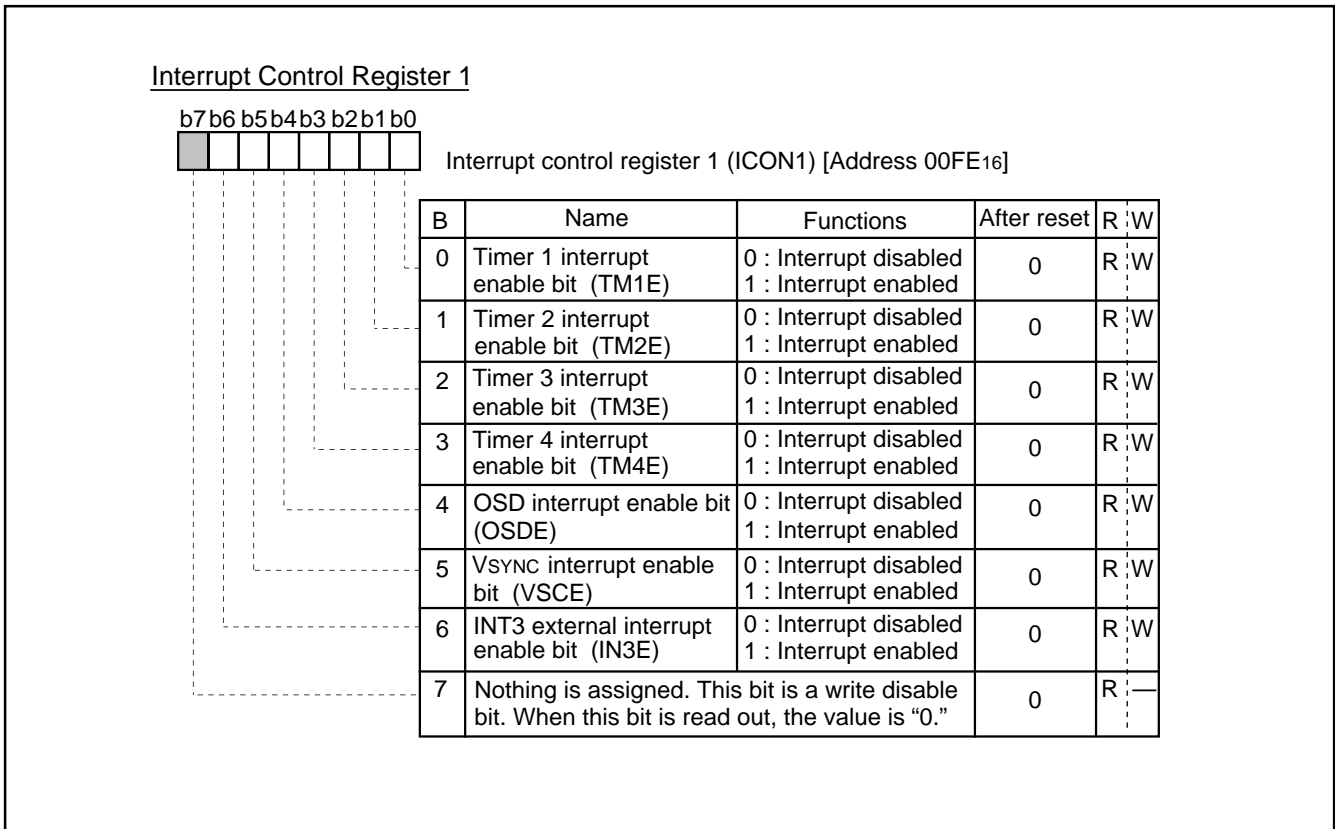

Fig. 8.3.4 Interrupt Control Register 1

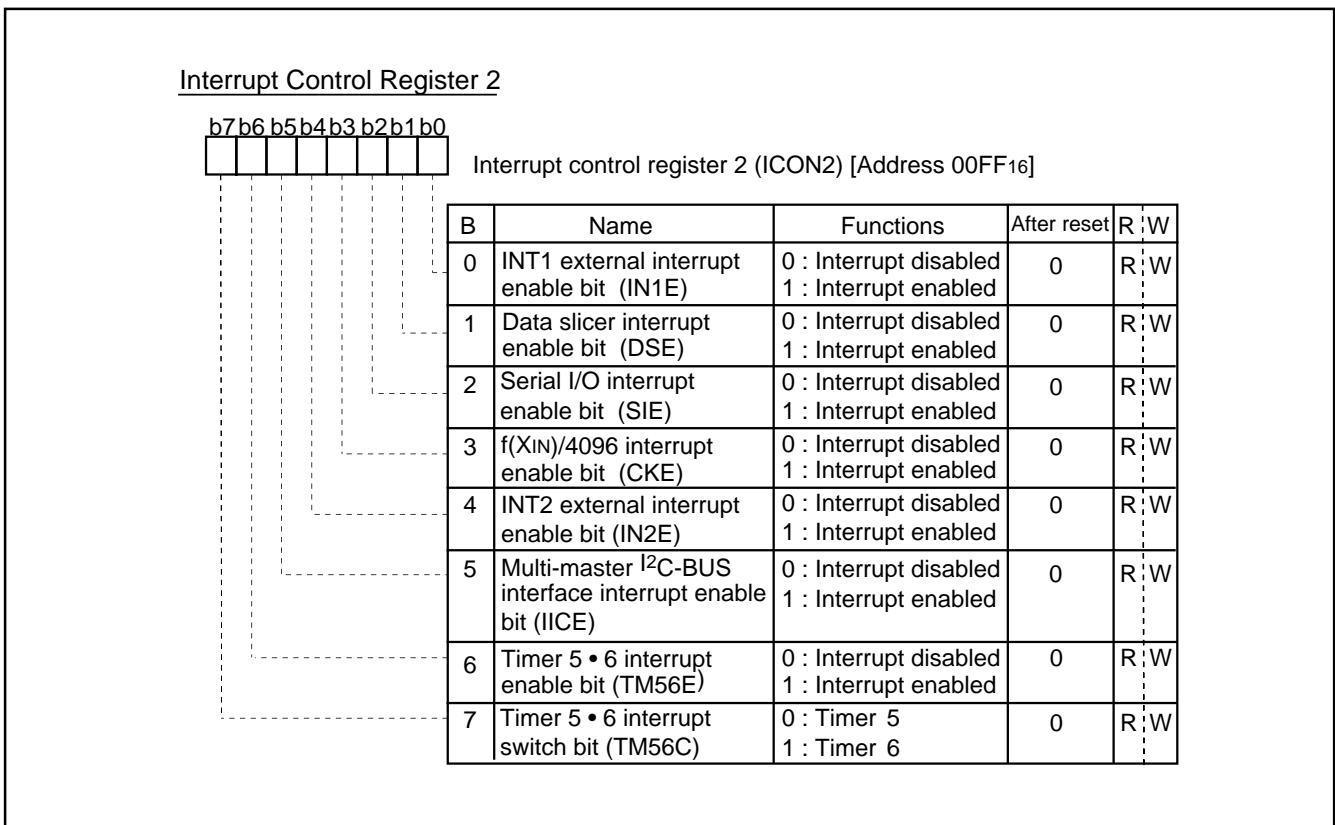
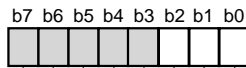

Fig. 8.3.5 Interrupt Control Register 2

M37151M6/M8/MA/MC/MF-XXXFP, M37151EFFP

SINGLE-CHIP 8-BIT CMOS MICROCOMPUTER with CLOSED CAPTION DECODER
and ON-SCREEN DISPLAY CONTROLLER

Interrupt Input Polarity Register



Interrupt input polarity register (RE) [Address 00DC₁₆]

B	Name	Functions	After reset	R ; W
0	INT1 polarity switch bit (INT1)	0 : Positive polarity 1 : Negative polarity	0	R ; W
1	INT2 polarity switch bit (INT2)	0 : Positive polarity 1 : Negative polarity	0	R ; W
2	INT3 polarity switch bit (INT3)	0 : Positive polarity 1 : Negative polarity	0	R ; W
3 to 7	Nothing is assigned. These bits are write disable bits. When these bits are read out, the values are "0."		0	R ; —

Fig. 8.3.6 Interrupt Input Polarity Register

M37151M6/M8/MA/MC/MF-XXXFP, M37151EFP

SINGLE-CHIP 8-BIT CMOS MICROCOMPUTER with CLOSED CAPTION DECODER
and ON-SCREEN DISPLAY CONTROLLER

8.4 TIMERS

This microcomputer has 6 timers: timer 1, timer 2, timer 3, timer 4, timer 5, and timer 6. All timers are 8-bit timers with the 8-bit timer latch. The timer block diagram is shown in Figure 8.4.3.

All of the timers count down and their divide ratio is $1/(n+1)$, where n is the value of timer latch. By writing a count value to the corresponding timer latch (addresses 00F0₁₆ to 00F3₁₆: timers 1 to 4, addresses 00EE₁₆ and 00EF₁₆: timers 5 and 6), the value is also set to a timer, simultaneously.

The count value is decremented by 1. The timer interrupt request bit is set to "1" by a timer overflow at the next count pulse, after the count value reaches "00₁₆".

8.4.1 Timer 1

Timer 1 can select one of the following count sources:

- $f(XIN)/16$ or $f(XCIN)/16$
- $f(XIN)/4096$ or $f(XCIN)/4096$
- External clock from the TIM2 pin

The count source of timer 1 is selected by setting bits 5 and 0 of timer mode register 1 (address 00F4₁₆). Either $f(XIN)$ or $f(XCIN)$ is selected by bit 7 of the CPU mode register.

Timer 1 interrupt request occurs at timer 1 overflow.

8.4.2 Timer 2

Timer 2 can select one of the following count sources:

- $f(XIN)/16$ or $f(XCIN)/16$
- Timer 1 overflow signal
- External clock from the TIM2 pin

The count source of timer 2 is selected by setting bits 4 and 1 of timer mode register 1 (address 00F4₁₆). Either $f(XIN)$ or $f(XCIN)$ is selected by bit 7 of the CPU mode register. When timer 1 overflow signal is a count source for the timer 2, the timer 1 functions as an 8-bit prescaler.

Timer 2 interrupt request occurs at timer 2 overflow.

8.4.3 Timer 3

Timer 3 can select one of the following count sources:

- $f(XIN)/16$ or $f(XCIN)/16$
- $f(XCIN)$
- External clock from the TIM3 pin

The count source of timer 3 is selected by setting bit 0 of timer mode register 2 (address 00F5₁₆) and bit 6 at address 00C7₁₆. Either $f(XIN)$ or $f(XCIN)$ is selected by bit 7 of the CPU mode register.

Timer 3 interrupt request occurs at timer 3 overflow.

8.4.4 Timer 4

Timer 4 can select one of the following count sources:

- $f(XIN)/16$ or $f(XCIN)/16$
- $f(XIN)/2$ or $f(XCIN)/2$
- $f(XCIN)$

The count source of timer 3 is selected by setting bits 1 and 4 of the timer mode register 2 (address 00F5₁₆). Either $f(XIN)$ or $f(XCIN)$ is selected by bit 7 of the CPU mode register. When timer 3 overflow signal is a count source for the timer 4, the timer 3 functions as an 8-bit prescaler.

Timer 4 interrupt request occurs at timer 4 overflow.

8.4.5 Timer 5

Timer 5 can select one of the following count sources:

- $f(XIN)/16$ or $f(XCIN)/16$
- Timer 2 overflow signal
- Timer 4 overflow signal

The count source of timer 3 is selected by setting bit 6 of timer mode register 1 (address 00F4₁₆) and bit 7 of the timer mode register 2 (address 00F5₁₆). When overflow of timer 2 or 4 is a count source for timer 5, either timer 2 or 4 functions as an 8-bit prescaler. Either $f(XIN)$ or $f(XCIN)$ is selected by bit 7 of the CPU mode register.

Timer 5 interrupt request occurs at timer 5 overflow.

8.4.6 Timer 6

Timer 6 can select one of the following count sources:

- $f(XIN)/16$ or $f(XCIN)/16$
- Timer 5 overflow signal

The count source of timer 6 is selected by setting bit 7 of the timer mode register 1 (address 00F4₁₆). Either $f(XIN)$ or $f(XCIN)$ is selected by bit 7 of the CPU mode register. When timer 5 overflow signal is a count source for timer 6, the timer 5 functions as an 8-bit prescaler. Timer 6 interrupt request occurs at timer 6 overflow.

At reset, timers 3 and 4 are connected by hardware and "FF₁₆" is automatically set in timer 3; "07₁₆" in timer 4. The $f(XIN)*/16$ is selected as the timer 3 count source. The internal reset is released by timer 4 overflow in this state and the internal clock is connected.

At execution of the STP instruction, timers 3 and 4 are connected by hardware and "FF₁₆" is automatically set in timer 3; "07₁₆" in timer 4. However, the $f(XIN)*/16$ is not selected as the timer 3 count source. So set both bit 0 of timer mode register 2 (address 00F5₁₆) and bit 6 at address 00C7₁₆ to "0" before the execution of the STP instruction ($f(XIN)*/16$ is selected as timer 3 count source). The internal STP state is released by timer 4 overflow in this state and the internal clock is connected.

As a result of the above procedure, the program can start under a stable clock.

*: When CPU Mode Register bit 7 (CM7) = 1, $f(XIN)$ becomes $f(XCIN)$.

The timer-related registers is shown in Figures 8.4.1 and 8.4.2.

The input path for the TIM2 pin can be selected between ports P16 or P24. Use Port P3 Direction Register (address 00C7₁₆) bit 7 to select either port.

M37151M6/M8/MA/MC/MF-XXXFP, M37151EFFP

SINGLE-CHIP 8-BIT CMOS MICROCOMPUTER with CLOSED CAPTION DECODER
and ON-SCREEN DISPLAY CONTROLLER

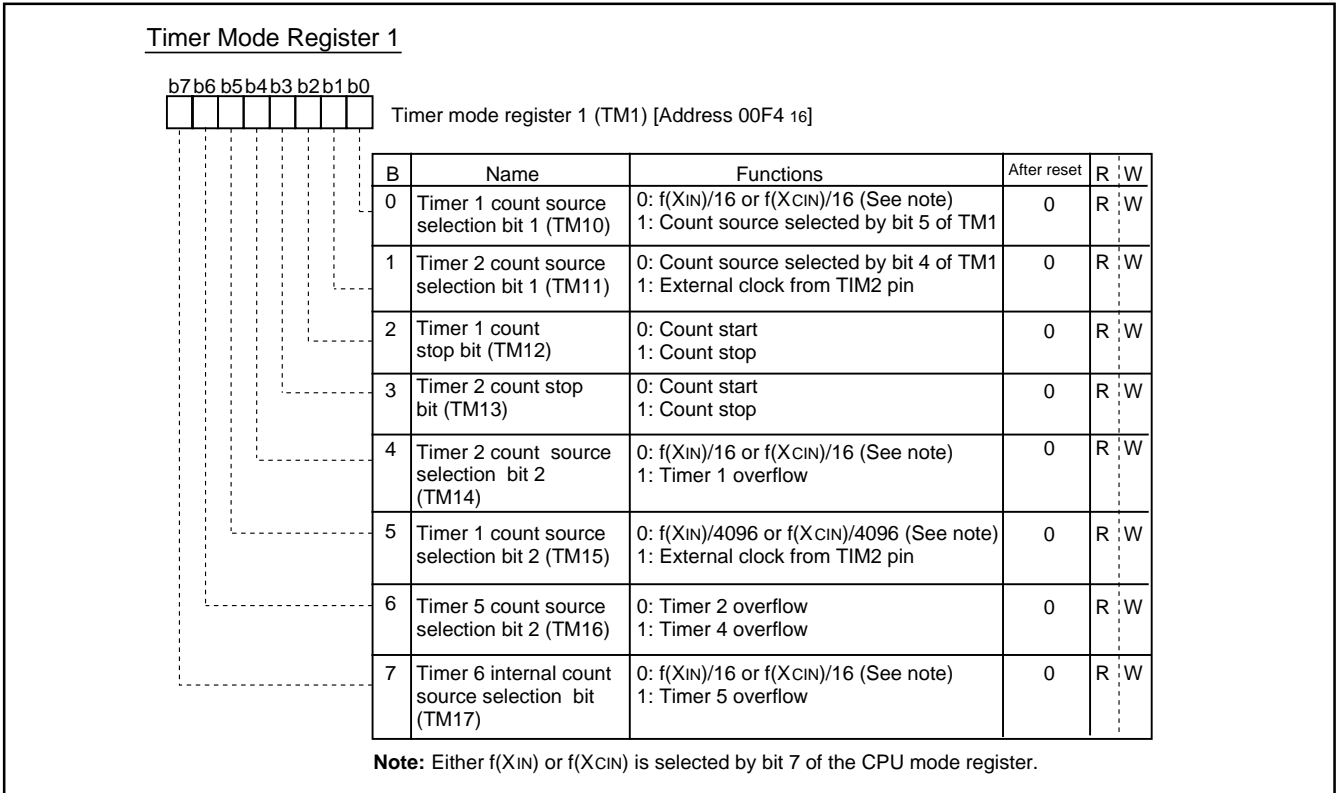

Fig. 8.4.1 Timer Mode Register 1

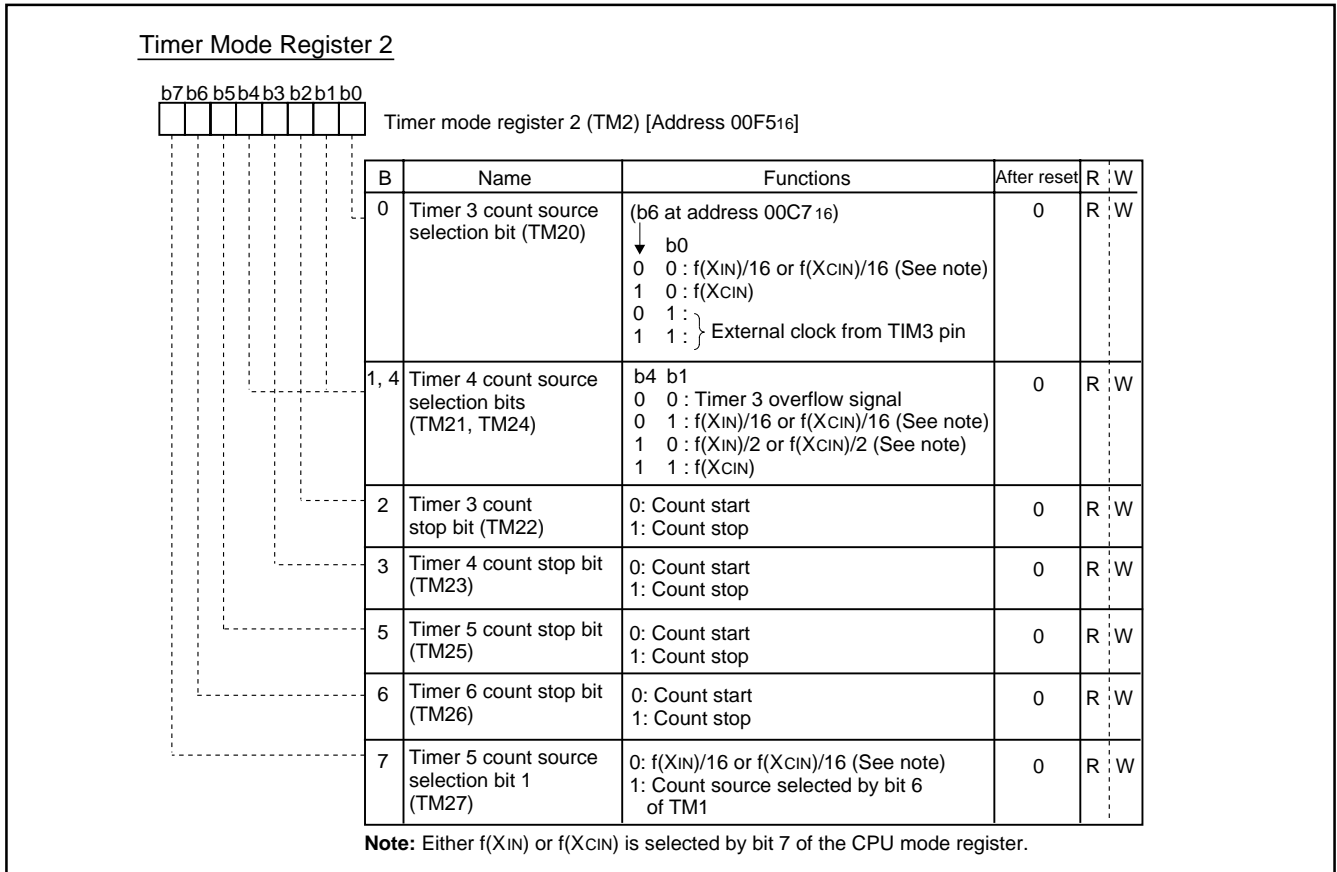
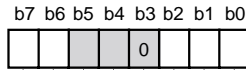

Fig. 8.4.2 Timer Mode Register 2

M37151M6/M8/MA/MC/MF-XXXFP, M37151EFP

SINGLE-CHIP 8-BIT CMOS MICROCOMPUTER with CLOSED CAPTION DECODER
and ON-SCREEN DISPLAY CONTROLLER

Port P3 direction register



Port P3 direction register (D3) [Address 00C7₁₆]

B	Name	Functions	After reset	R	W
0	Port P3 ₀ direction register (See note 1)	0 : Port P3 ₀ input 1 : Port P3 ₀ output	0	R	W
1		0 : Port P3 ₁ input 1 : Port P3 ₁ output	0	R	W
2	Output amplitude level selection bit (OUTS) (See note 2)	0 : 2 value output 1 : 3 value output	0	R	W
3	Fix this bit to "0."		0	R	W
4,5	Nothing is assigned fix these bits When this bit are read out, the value are "0."		0	R	-
6	Timer 3 (T3SC)	Refer to explanation of a timer	0	R	W
7	Timer 2 (T2SC)	0 : P2 ₄ input 1 : P1 ₆ input	0	R	W

Notes 1: When using the port as the I²C-BUS interface, set the Port P3 Direction Register to 1.
2: Use the Clock Control Register 3 (address 0212₁₆) bit 5 to select the binary output level of OUT.

Fig. 8.4.3 Port P3 direction register

Timer return setting register

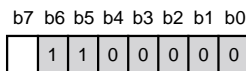

Timer return setting register (TMS) [Address 00CC₁₆]

B	Name	Functions	After reset	R	W
0 to 4	Fix these bits to "0."		0	R	W
5, 6	Fix these bits to "1."		0	R	W
7	STOP mode return selection bit (TMS)	0: Timer Count "07FF ₁₆ " 1: Timer Count Variable	0	R	W

Fig. 8.4.4 Timer return setting register

M37151M6/M8/MA/MC/MF-XXXFP, M37151EFP

SINGLE-CHIP 8-BIT CMOS MICROCOMPUTER with CLOSED CAPTION DECODER
and ON-SCREEN DISPLAY CONTROLLER

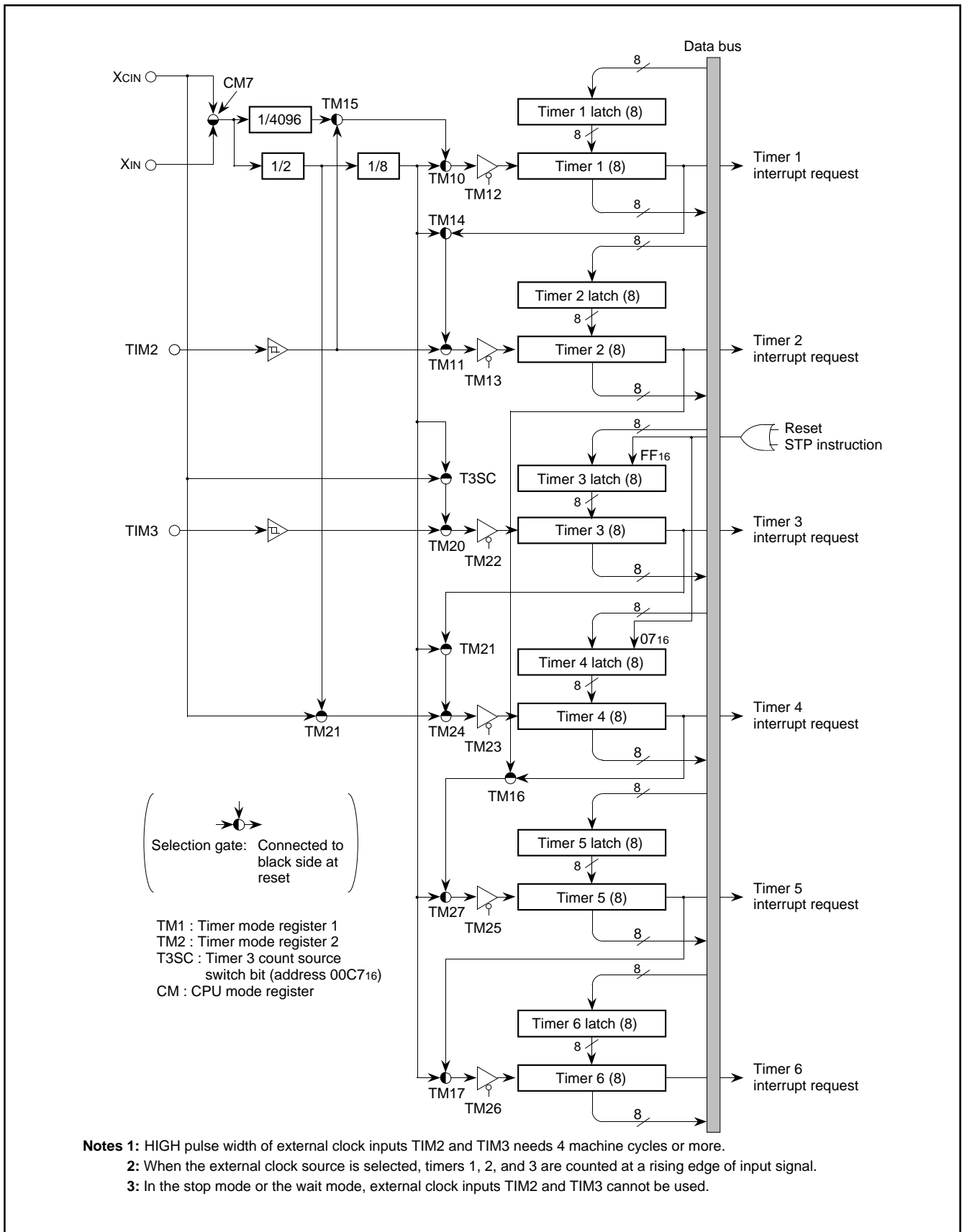

Fig. 8.4.5 Timer Block Diagram

M37151M6/M8/MA/MC/MF-XXXFP, M37151EFP

SINGLE-CHIP 8-BIT CMOS MICROCOMPUTER with CLOSED CAPTION DECODER and ON-SCREEN DISPLAY CONTROLLER

8.5 SERIAL I/O

This microcomputer has a built-in serial I/O which can either transmit or receive 8-bit data serially in the clock synchronous mode.

The serial I/O block diagram is shown in Figure 8.5.1. The synchronous clock I/O pin (SCLK), and data output pin (SOUT) also function as port P4, data input pin (SIN) also functions as port P20–P22.

Bit 3 of the serial I/O mode register (address 00EB16) selects whether the synchronous clock is supplied internally or externally (from the SCLK pin). When an internal clock is selected, bits 1 and 0 select whether $f(XIN)$ or $f(XCIN)$ is divided by 8, 16, 32, or 64. To use the SIN pin for serial I/O, set the corresponding bit of the port P2 direction register (address 00C516) to "0."

The operation of the serial I/O is described below. The operation of the serial I/O differs depending on the clock source; external clock or internal clock.

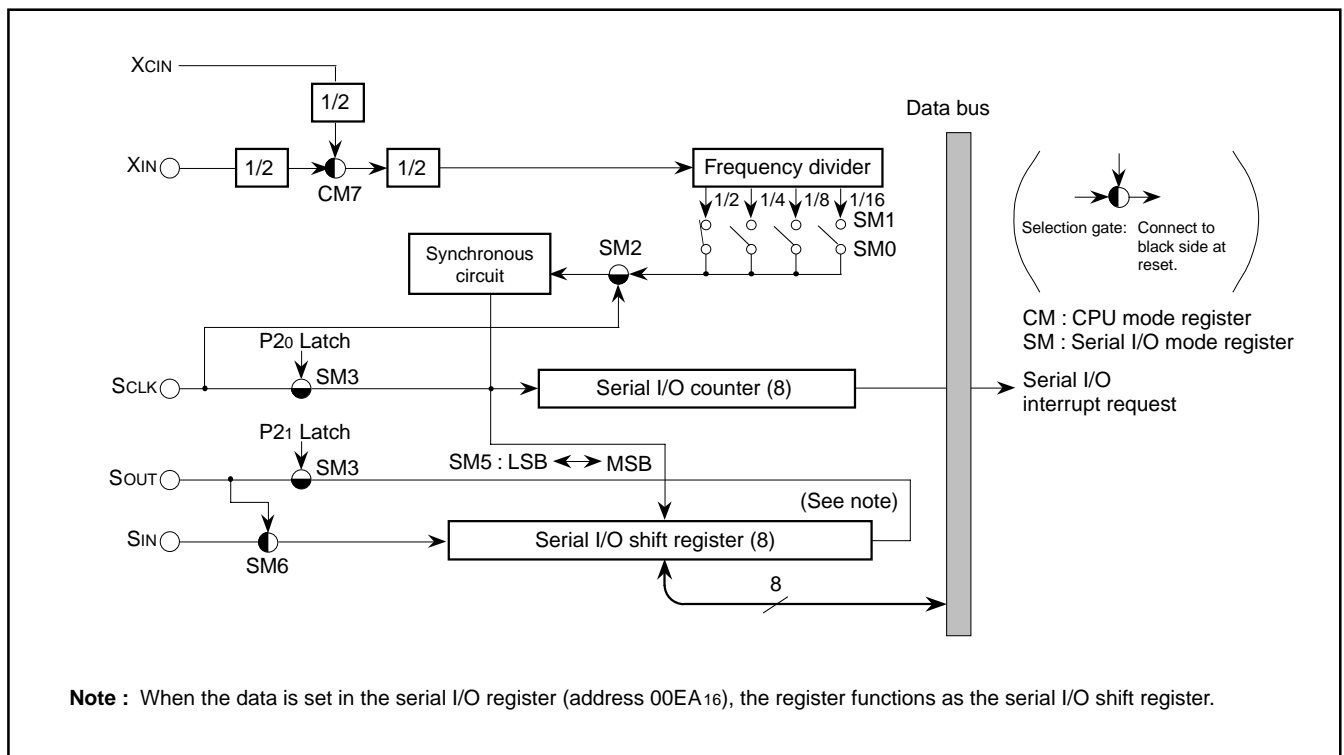

Fig. 8.5.1 Serial I/O Block Diagram

M37151M6/M8/MA/MC/MF-XXXFP, M37151EFFP

SINGLE-CHIP 8-BIT CMOS MICROCOMPUTER with CLOSED CAPTION DECODER
and ON-SCREEN DISPLAY CONTROLLER

Internal clock : The serial I/O counter is set to "7" during the write cycle into the serial I/O register (address 00EA16), and the transfer clock goes HIGH forcibly. At each falling edge of the transfer clock after the write cycle, serial data is output from the SOUT pin. Transfer direction can be selected by bit 5 of the serial I/O mode register. At each rising edge of the transfer clock, data is input from the SIN pin and data in the serial I/O register is shifted 1 bit. After the transfer clock has counted 8 times, the serial I/O counter becomes "0" and the transfer clock stops at HIGH. At this time the interrupt request bit is set to "1."

External clock : The an external clock is selected as the clock source, the interrupt request is set to "1" after the transfer clock has been counted 8 counts. However, transfer operation does not stop, so the clock should be controlled externally. Use the external clock of 1 MHz or less with a duty cycle of 50%. The serial I/O timing is shown in Figure 8.5.2. When using an external clock for transfer, the external clock must be held at HIGH for initializing the serial I/O counter. When switching between an internal clock and an external clock, do not switch during transfer. Also, be sure to initialize the serial I/O counter after switching.

- Notes 1:** On programming, note that the serial I/O counter is set by writing to the serial I/O register with the bit managing instructions, such as SEB and CLB.
- 2:** When an external clock is used as the synchronous clock, write transmit data to the serial I/O register when the transfer clock input level is HIGH.

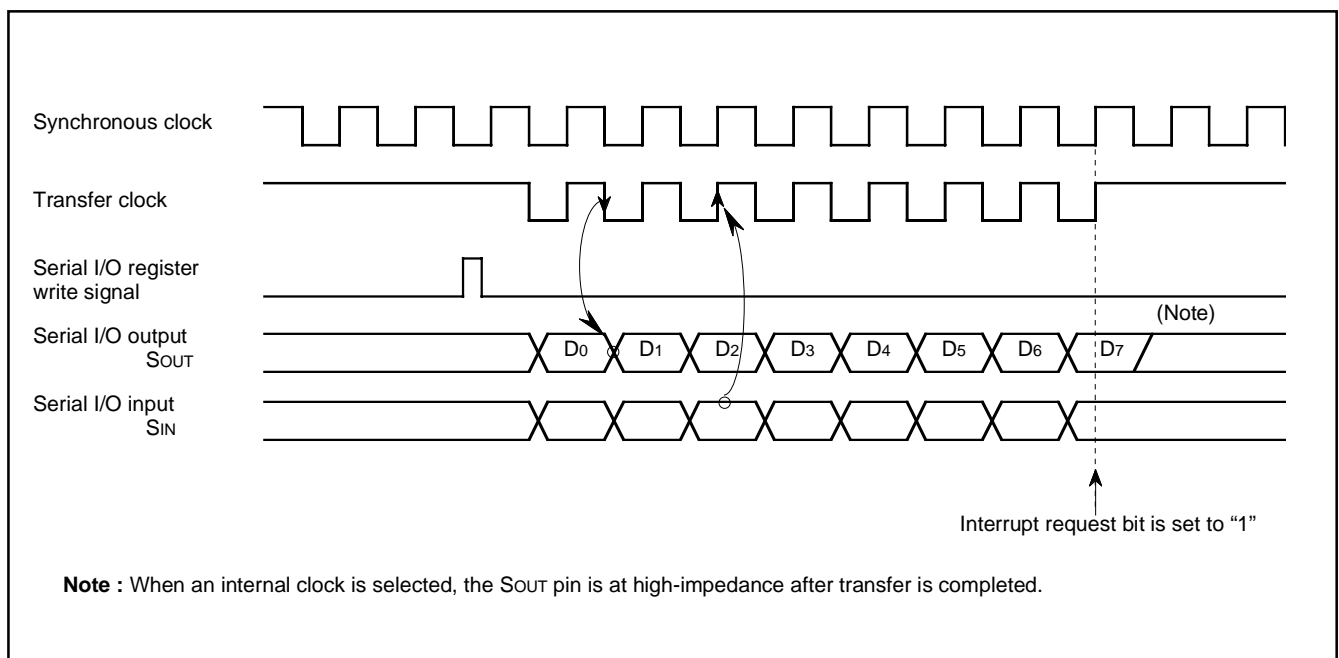

Fig. 8.5.2 Serial I/O Timing (for LSB first)

M37151M6/M8/MA/MC/MF-XXXFP, M37151EFP

SINGLE-CHIP 8-BIT CMOS MICROCOMPUTER with CLOSED CAPTION DECODER
and ON-SCREEN DISPLAY CONTROLLER

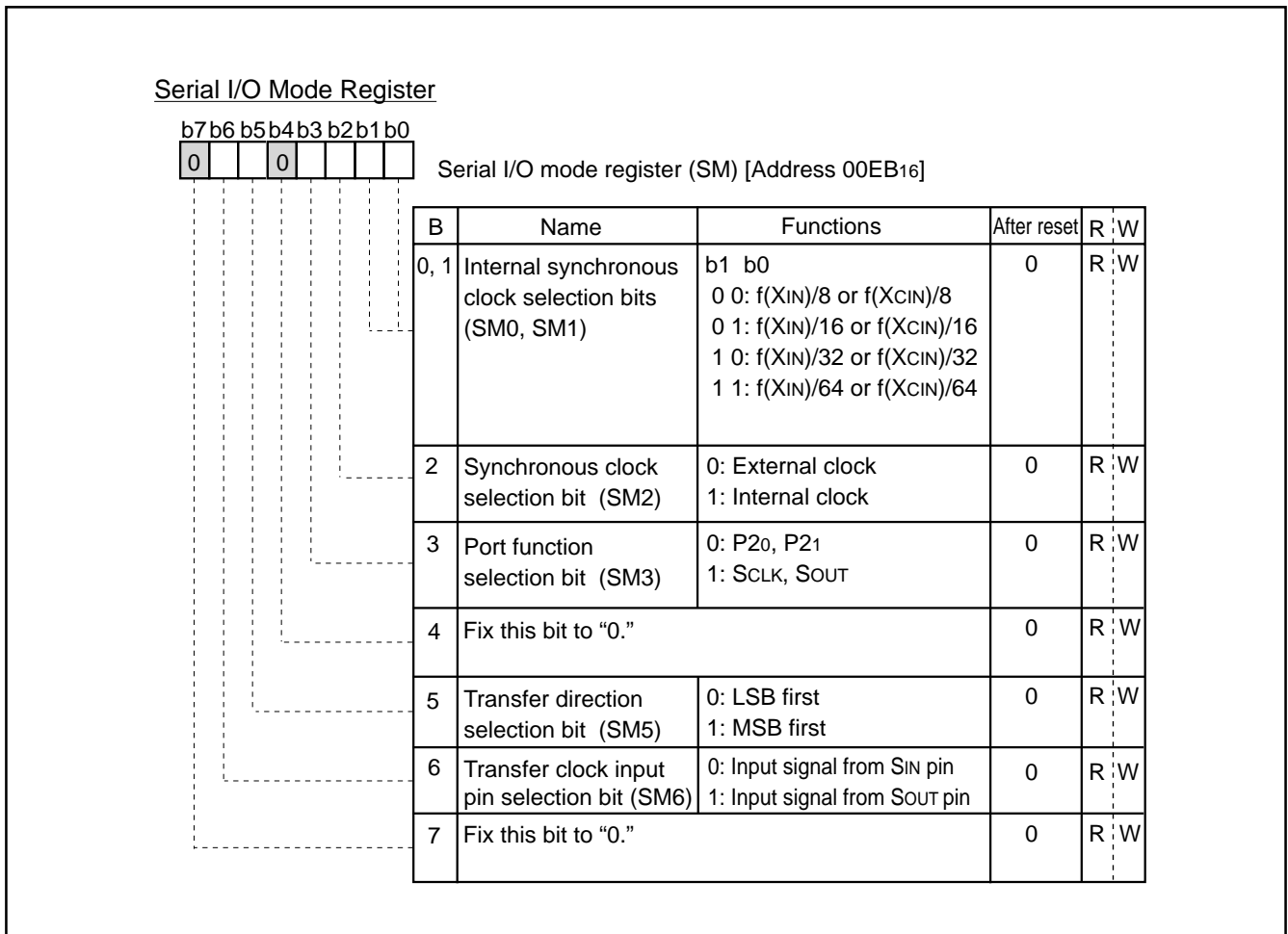

Fig. 8.5.3 Serial I/O Mode Register

M37151M6/M8/MA/MC/MF-XXXFP, M37151EFFP

SINGLE-CHIP 8-BIT CMOS MICROCOMPUTER with CLOSED CAPTION DECODER and ON-SCREEN DISPLAY CONTROLLER

8.6 MULTI-MASTER I²C-BUS INTERFACE

The multi-master I²C-BUS interface is a serial communications circuit, conforming to the Philips I²C-BUS data transfer format. This interface, offering both arbitration lost detection and synchronous function, is useful for multi-master serial communications.

Figure 8.6.1 shows a block diagram of the multi-master I²C-BUS interface and Table 8.6.1 shows multi-master I²C-BUS interface functions.

This multi-master I²C-BUS interface consists of the address register, the data shift register, the clock control register, the control register, the status register and other control circuits.

Table 8.6.1 Multi-master I²C-BUS Interface Functions

Item	Function
Format	In conformity with Philips I ² C-BUS standard: 10-bit addressing format 7-bit addressing format High-speed clock mode Standard clock mode
Communication mode	In conformity with Philips I ² C-BUS standard: Master transmission Master reception Slave transmission Slave reception
SCL clock frequency	16.1 kHz to 400 kHz ($\phi =$ at 4 MHz)

ϕ : System clock = $f(XIN)/2$

Note : We are not responsible for any third party's infringement of patent rights or other rights attributable to the use of the control function (bits 6 and 7 of the I²C control register at address 00F916) for connections between the I²C-BUS interface and ports (SCL1, SCL2, SDA1, SDA2).

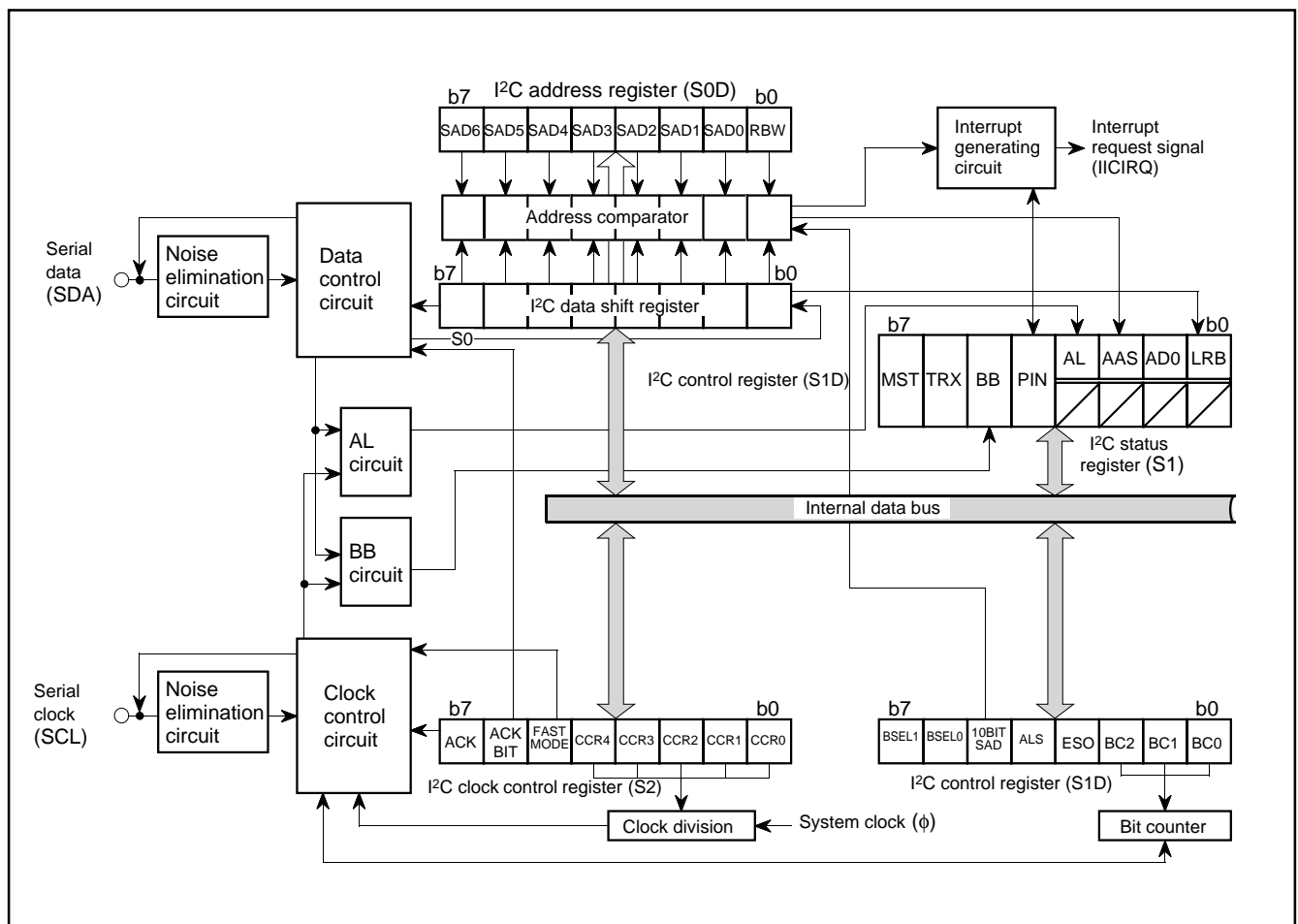

Fig. 8.6.1 Block Diagram of Multi-master I²C-BUS Interface

M37151M6/M8/MA/MC/MF-XXXFP, M37151EFP

SINGLE-CHIP 8-BIT CMOS MICROCOMPUTER with CLOSED CAPTION DECODER
and ON-SCREEN DISPLAY CONTROLLER

8.6.1 I²C Data Shift Register

The I²C data shift register (S0 : address 00F6₁₆) is an 8-bit shift register to store receive data and write transmit data.

When transmit data is written into this register, it is transferred to the outside from bit 7 in synchronization with the SCL clock, and each time one-bit data is output, the data of this register are shifted one bit to the left. When data is received, it is input to this register from bit 0 in synchronization with the SCL clock, and each time one-bit data is input, the data of this register are shifted one bit to the left.

The I²C data shift register is in a write enable status only when the ESO bit of the I²C control register (address 00F9₁₆) is "1." The bit counter is reset by a write instruction to the I²C data shift register. When both the ESO bit and the MST bit of the I²C status register (address 00F8₁₆) are "1," the SCL is output by a write instruction to the I²C data shift register. Reading data from the I²C data shift register is always enabled regardless of the ESO bit value.

Note: To write data into the I²C data shift register after setting the MST bit to "0" (slave mode), keep an interval of 8 machine cycles or more.

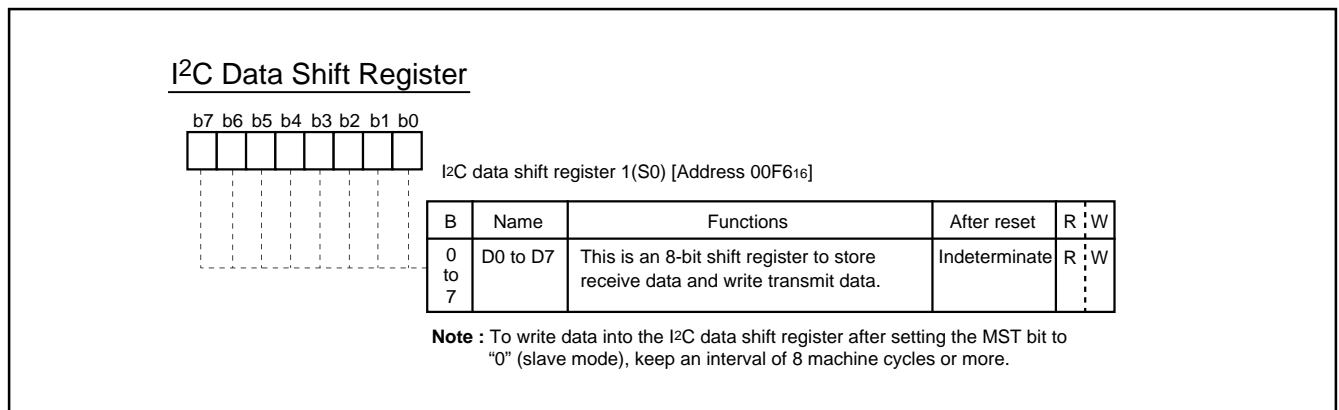

Fig. 8.6.2 I²C Data Shift Register

M37151M6/M8/MA/MC/MF-XXXFP, M37151EFFP

SINGLE-CHIP 8-BIT CMOS MICROCOMPUTER with CLOSED CAPTION DECODER
and ON-SCREEN DISPLAY CONTROLLER

8.6.2 I²C Address Register

The I²C address register (address 00F7₁₆) consists of a 7-bit slave address and a read/write bit. In the addressing mode, the slave address written in this register is compared with the address data to be received immediately after the START condition is detected.

(1) Bit 0: read/write bit (RBW)

Not used when comparing addresses in the 7-bit addressing mode. In the 10-bit addressing mode, the first address data to be received is compared with the contents (SAD₆ to SAD₀ + RBW) of the I²C address register.

The RBW bit is cleared to "0" automatically when the stop condition is detected.

(2) Bits 1 to 7: slave address (SAD₀–SAD₆)

These bits store slave addresses. Regardless of the 7-bit addressing mode and the 10-bit addressing mode, the address data transmitted from the master is compared with the contents of these bits.

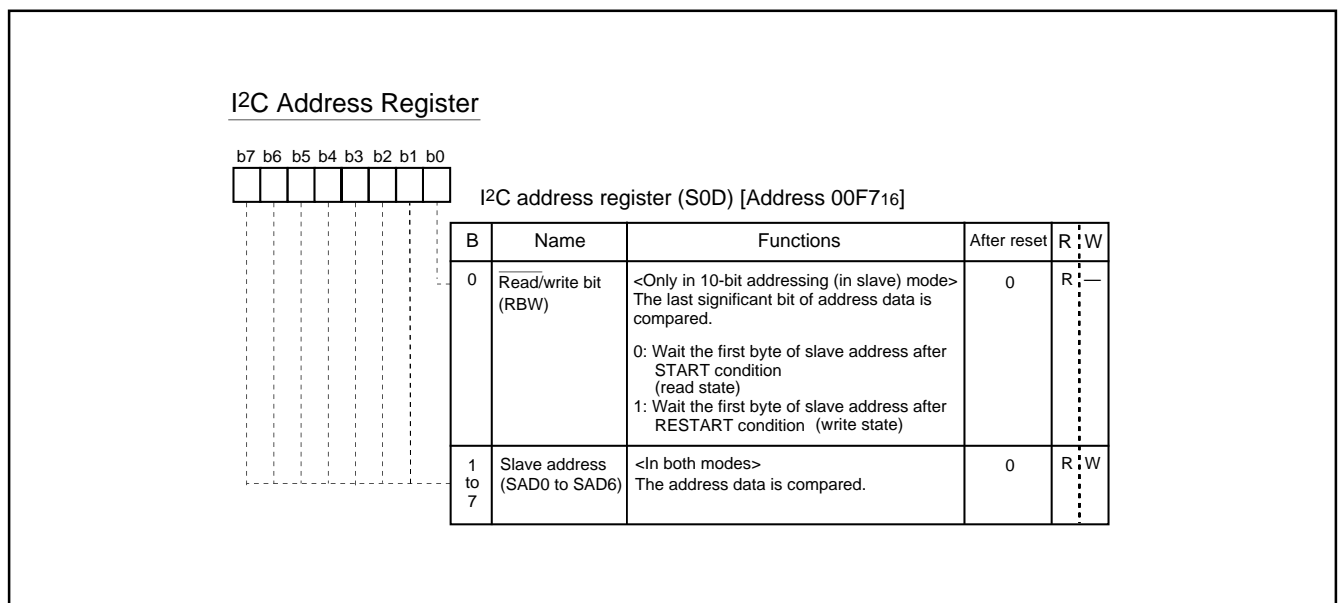

Fig. 8.6.3 I²C Address Register

M37151M6/M8/MA/MC/MF-XXXFP, M37151EFP

SINGLE-CHIP 8-BIT CMOS MICROCOMPUTER with CLOSED CAPTION DECODER and ON-SCREEN DISPLAY CONTROLLER

8.6.3 I²C Clock Control Register

The I²C clock control register (address 00FA16) is used to set ACK control, SCL mode and SCL frequency.

(1) Bits 0 to 4: SCL frequency control bits (CCR0–CCR4)

These bits control the SCL frequency.

(2) Bit 5: SCL mode specification bit (FAST MODE)

This bit specifies the SCL mode. When this bit is set to “0,” the standard clock mode is set. When the bit is set to “1,” the high-speed clock mode is set.

(3) Bit 6: ACK bit (ACK BIT)

This bit sets the SDA status when an ACK clock* is generated. When this bit is set to “0,” the ACK return mode is set and SDA goes to LOW at the occurrence of an ACK clock. When the bit is set to “1,” the ACK non-return mode is set. The SDA is held in the HIGH status at the occurrence of an ACK clock.

However, when the slave address matches the address data in the reception of address data at ACK BIT = “0,” the SDA automatically goes to LOW (ACK is returned). If there is a mismatch between the slave address and the address data, the SDA automatically goes to HIGH (ACK is not returned).

(4) Bit 7: ACK clock bit (ACK)

This bit specifies a mode of acknowledgment which is an acknowledgment response of data transmission. When this bit is set to “0,” the no ACK clock mode is set. In this case, no ACK clock occurs after data transmission. When the bit is set to “1,” the ACK clock mode is set and the master generates an ACK clock upon completion of each 1-byte data transmission. The device for transmitting address data and control data releases the SDA at the occurrence of an ACK clock (make SDA HIGH) and receives the ACK bit generated by the data receiving device.

Note: Do not write data into the I²C clock control register during transmission. If data is written during transmission, the I²C clock generator is reset, so that data cannot be transmitted normally.

*ACK clock: Clock for acknowledgement

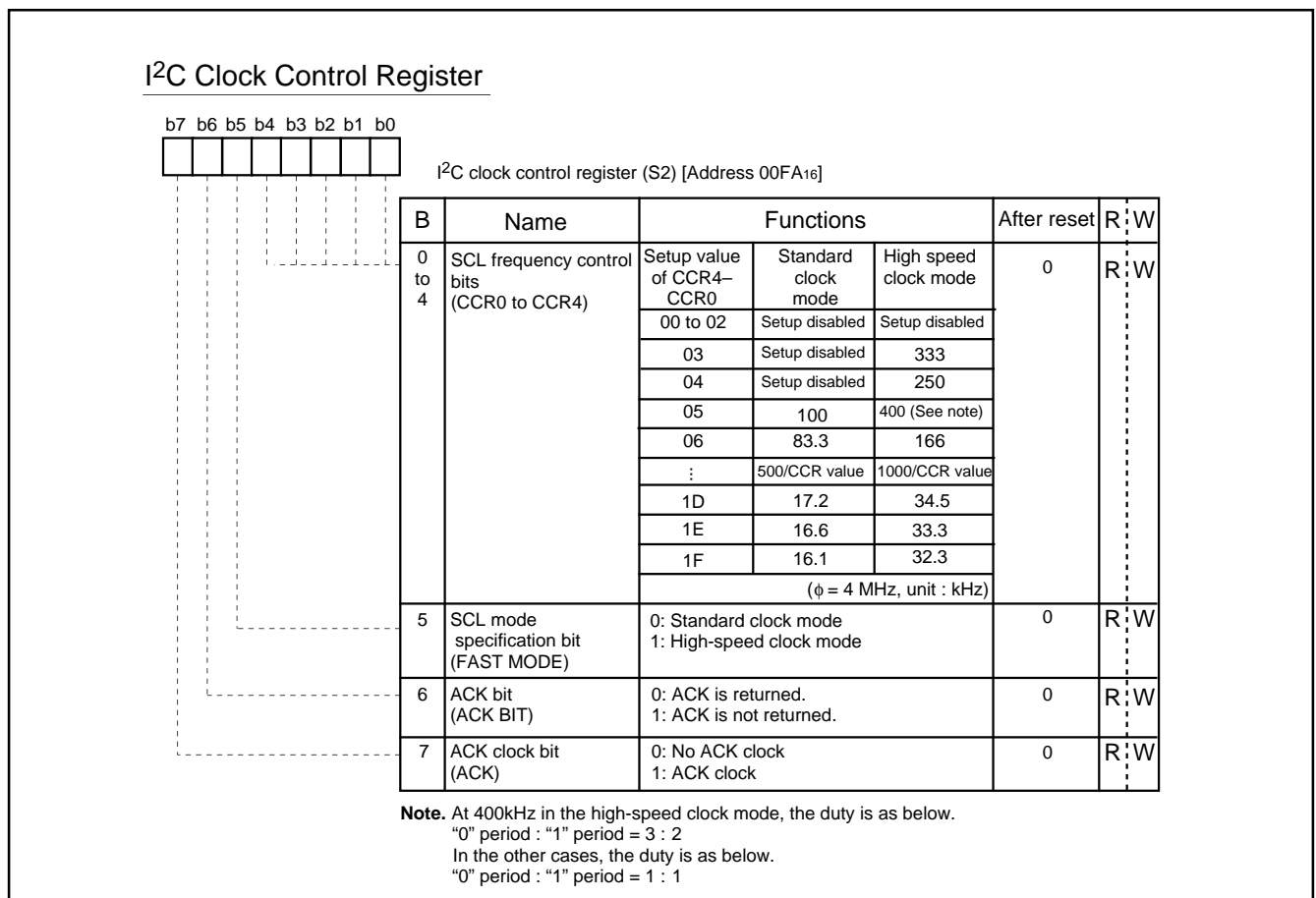

Fig. 8.6.4 I²C Clock Control Register

M37151M6/M8/MA/MC/MF-XXXFP, M37151EFP

SINGLE-CHIP 8-BIT CMOS MICROCOMPUTER with CLOSED CAPTION DECODER
and ON-SCREEN DISPLAY CONTROLLER

8.6.4 I²C Control Register

The I²C control register (address 00F9₁₆) controls the data communication format.

(1) Bits 0 to 2: bit counter (BC0–BC2)

These bits decide the number of bits for the next 1-byte data to be transmitted. An interrupt request signal occurs immediately after the number of bits specified with these bits are transmitted.

When a START condition is received, these bits become "000₂" and the address data is always transmitted and received in 8 bits.

(2) Bit 3: I²C interface use enable bit (ESO)

This bit enables usage of the multimaster I²C BUS interface. When this bit is set to "0," interface is in the disable status, so the SDA and the SCL become high-impedance. When the bit is set to "1," use of the interface is enabled.

When ESO = "0," the following is performed.

- PIN = "1," BB = "0" and AL = "0" are set (they are bits of the I²C status register at address 00F8₁₆).
- Writing data to the I²C data shift register (address 00F6₁₆) is disabled.

(3) Bit 4: data format selection bit (ALS)

This bit decides whether or not to recognize slave addresses. When this bit is set to "0," the addressing format is selected, so that address data is recognized. When a match is found between a slave address and address data as a result of comparison or when a general call (refer to "8.6.5 I²C Status Register," bit 1) is received, transmission processing can be performed. When this bit is set to "1," the free data format is selected, so that slave addresses are not recognized.

(4) Bit 5: addressing format selection bit (10BIT SAD)

This bit selects a slave address specification format. When this bit is set to "0," the 7-bit addressing format is selected. In this case, only the high-order 7 bits (slave address) of the I²C address register (address 00F7₁₆) are compared with address data. When this bit is set to "1," the 10-bit addressing format is selected and all the bits of the I²C address register are compared with the address data.

(5) Bits 6 and 7: connection control bits between I²C-BUS interface and ports (BSEL0, BSEL1)

These bits control the connection between SCL and ports or SDA and ports (refer to Figure 8.6.5).

Note: To connect with SCL3 and SDA3, set bits 2 and 3 of the port P3 register (00C6₁₆).

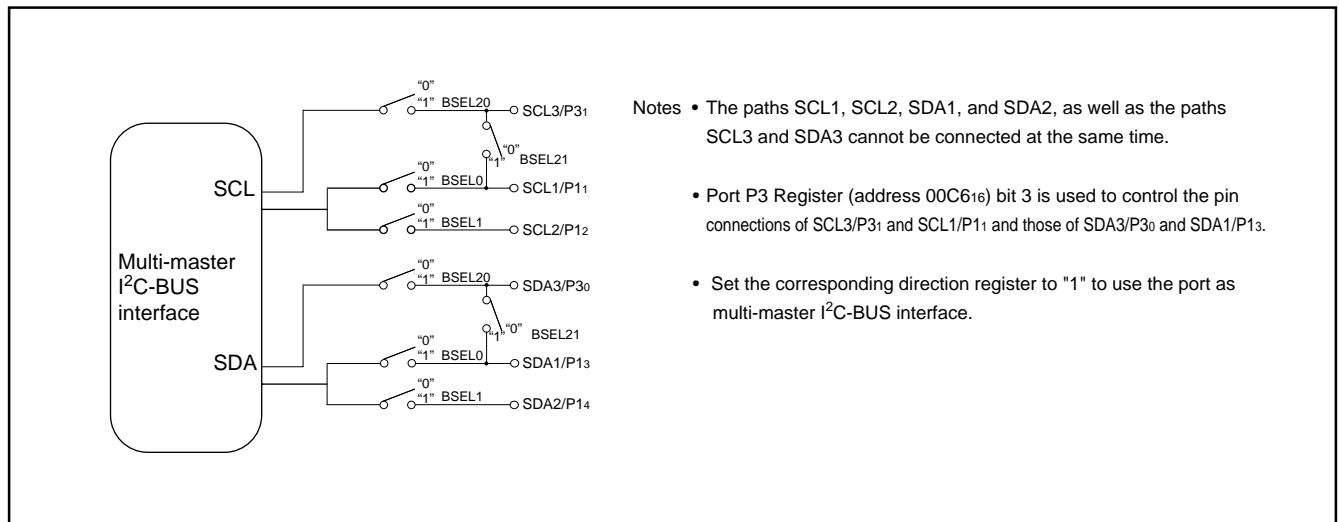

Notes

- The paths SCL1, SCL2, SDA1, and SDA2, as well as the paths SCL3 and SDA3 cannot be connected at the same time.

- Port P3 Register (address 00C6₁₆) bit 3 is used to control the pin connections of SCL3/P3₁ and SCL1/P1₁ and those of SDA3/P3₀ and SDA1/P1₃.
- Set the corresponding direction register to "1" to use the port as multi-master I²C-BUS interface.

Fig. 8.6.5 Connection Port Control by BSEL0 and BSEL1

M37151M6/M8/MA/MC/MF-XXXFP, M37151EFP

SINGLE-CHIP 8-BIT CMOS MICROCOMPUTER with CLOSED CAPTION DECODER
and ON-SCREEN DISPLAY CONTROLLER

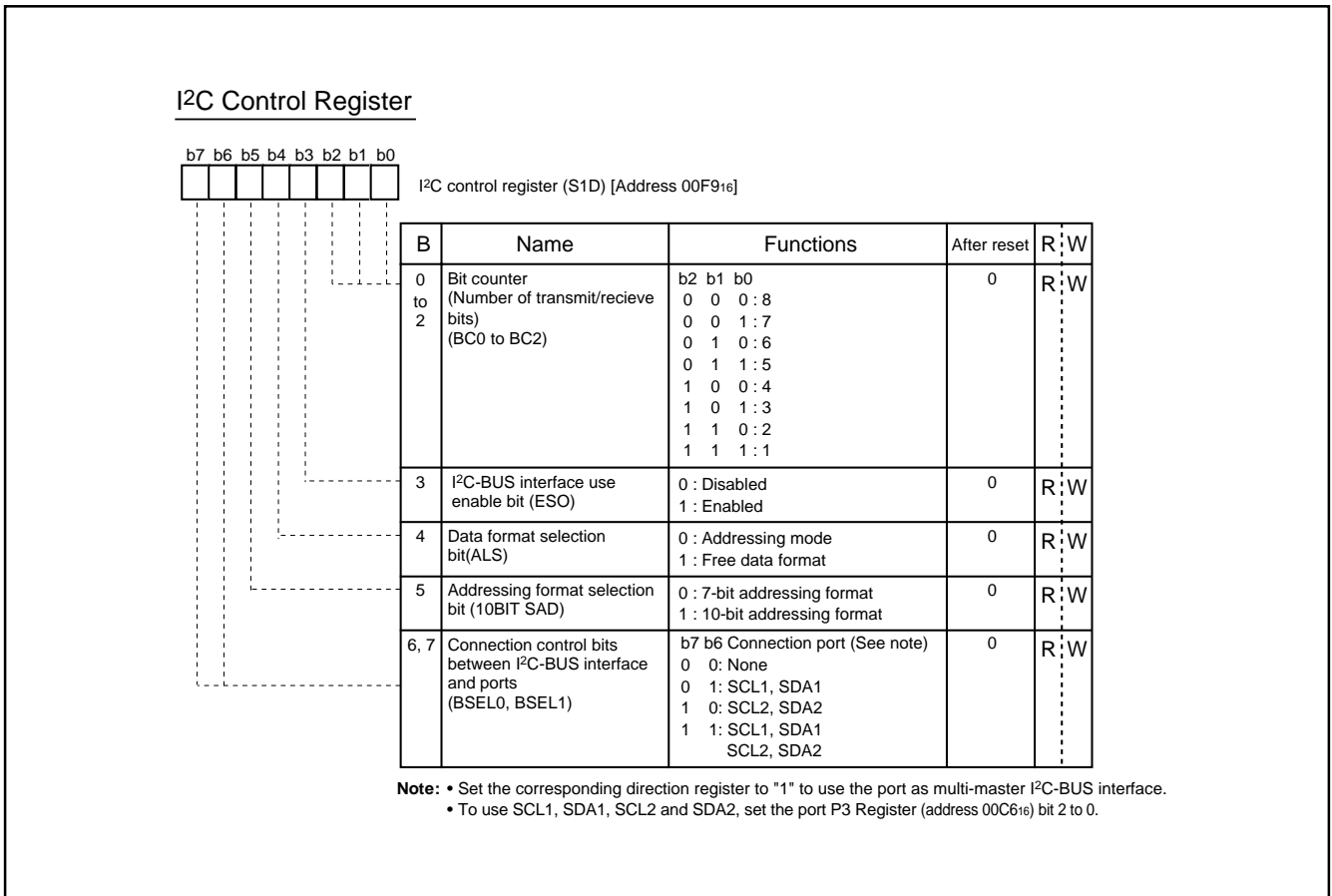

Fig. 8.6.6 I²C Control Register

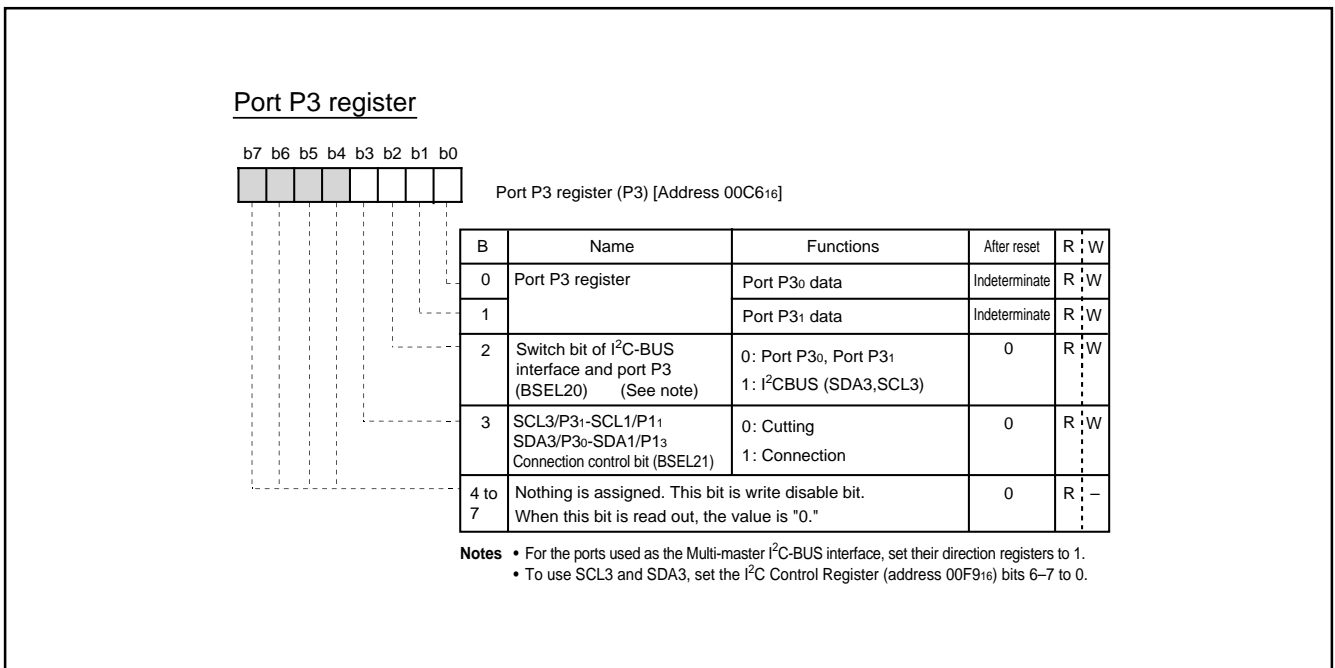

Fig. 8.6.7 Port P3 Register

M37151M6/M8/MA/MC/MF-XXXFP, M37151EFPSINGLE-CHIP 8-BIT CMOS MICROCOMPUTER with CLOSED CAPTION DECODER
and ON-SCREEN DISPLAY CONTROLLER**8.6.5 I²C Status Register**

The I²C status register (address 00F816) controls the I²C-BUS interface status. The low-order 4 bits are read-only bits and the high-order 4 bits can be read out and written to.

(1) Bit 0: last receive bit (LRB)

This bit stores the last bit value of received data and can also be used for ACK receive confirmation. If ACK is returned when an ACK clock occurs, the LRB bit is set to "0." If ACK is not returned, this bit is set to "1." Except in the ACK mode, the last bit value of received data is input. The state of this bit is changed from "1" to "0" by executing a write instruction to the I²C data shift register (address 00F616).

(2) Bit 1: general call detecting flag (AD0)

This bit is set to "1" when a general call* whose address data is all "0" is received in the slave mode. By a general call of the master device, every slave device receives control data after the general call. The AD0 bit is set to "0" by detecting the STOP condition or START condition.

*General call: The master transmits the general call address "0016" to all slaves.

(3) Bit 2: slave address comparison flag (AAS)

This flag indicates a comparison result of address data.

- In the slave receive mode, when the 7-bit addressing format is selected, this bit is set to "1" in either of the following conditions.
 - The address data immediately after occurrence of a START condition matches the slave address stored in the high-order 7 bits of the I²C address register (address 00F716).
 - A general call is received.
- In the slave reception mode, when the 10-bit addressing format is selected, this bit is set to "1" in the following condition.
 - When the address data is compared with the I²C address register (8 bits consisting of slave address and RBW), the first bytes match.
- The state of this bit is changed from "1" to "0" by executing a write instruction to the I²C data shift register (address 00F616).

(4) Bit 3: arbitration lost* detecting flag (AL)

In the master transmission mode, when a device other than the microcomputer sets the SDA to "L," arbitration is judged to have been lost, so that this bit is set to "1." At the same time, the TRX bit is set to "0," so that immediately after transmission of the byte whose arbitration was lost is completed, the MST bit is set to "0." When arbitration is lost during slave address transmission, the TRX bit is set to "0" and the reception mode is set. Consequently, it becomes possible to receive and recognize its own slave address transmitted by another master device.

*Arbitration lost: The status in which communication as a master is disabled.

(5) Bit 4: I²C-BUS interface interrupt request bit (PIN)

This bit generates an interrupt request signal. Each time 1-byte data is transmitted, the state of the PIN bit changes from "1" to "0." At the same time, an interrupt request signal is sent to the CPU. The PIN bit is set to "0" in synchronization with a falling edge of the last clock (including the ACK clock) of an internal clock and an interrupt request signal occurs in synchronization with a falling edge of the PIN bit. When the PIN bit is "0," the SCL is kept in the "0" state and clock generation is disabled. Figure 8.6.9 shows an interrupt request signal generating timing chart.

The PIN bit is set to "1" in any one of the following conditions.

- Executing a write instruction to the I²C data shift register (address 00F616).
- When the ESO bit is "0"
- At reset

The conditions in which the PIN bit is set to "0" are shown below:

- Immediately after completion of 1-byte data transmission (including when arbitration lost is detected)
- Immediately after completion of 1-byte data reception
- In the slave reception mode, with ALS = "0" and immediately after completion of slave address or general call address reception
- In the slave reception mode, with ALS = "1" and immediately after completion of address data reception

(6) Bit 5: bus busy flag (BB)

This bit indicates the status of the bus system. When this bit is set to "0," this bus system is not busy and a START condition can be generated. When this bit is set to "1," this bus system is busy and the occurrence of a START condition is disabled by the START condition duplication prevention function (See note).

This flag can be written by software only in the master transmission mode. In the other modes, this bit is set to "1" by detecting a START condition and set to "0" by detecting a STOP condition. When the ESO bit of the I²C control register (address 00F916) is "0" at reset, the BB flag is kept in the "0" state.

(7) Bit 6: communication mode specification bit (transfer direction specification bit: TRX)

This bit decides the direction of transfer for data communication. When this bit is "0," the reception mode is selected and the data of a transmitting device is received. When the bit is "1," the transmission mode is selected and address data and control data are output into the SDA in synchronization with the clock generated on the SCL.

When the ALS bit of the I²C control register (address 00F916) is "0" in the slave reception mode, the TRX bit is set to "1" (transmit) if the least significant bit (R/W bit) of the address data transmitted by the master is "1." When the ALS bit is "0" and the R/W bit is "0," the TRX bit is cleared to "0" (receive).

The TRX bit is cleared to "0" in one of the following conditions.

- When arbitration lost is detected.
- When a STOP condition is detected.
- When occurrence of a START condition is disabled by the START condition duplication prevention function (Note).
- When MST = "0" and a START condition is detected.
- When MST = "0" and ACK non-return is detected.
- At reset

M37151M6/M8/MA/MC/MF-XXXFP, M37151EFP

SINGLE-CHIP 8-BIT CMOS MICROCOMPUTER with CLOSED CAPTION DECODER
and ON-SCREEN DISPLAY CONTROLLER

(8) Bit 7: Communication mode specification bit (master/slave specification bit: MST)

This bit is used for master/slave specification in data communications. When this bit is "0," the slave is specified, so that a START condition and a STOP condition generated by the master are received, and data communication is performed in synchronization with the clock generated by the master. When this bit is "1," the master is specified and a START condition and a STOP condition are generated, and also the clocks required for data communication are generated on the SCL.

The MST bit is cleared to "0" in any of the following conditions.

- Immediately after completion of 1-byte data transmission when arbitration lost is detected
- When a STOP condition is detected.
- When occurrence of a START condition is disabled by the START condition duplication prevention function (Note).
- At reset

Note: The START condition duplication prevention function disables the START condition generation, bit counter reset, and SCL output, when the following condition is satisfied:
a START condition is set by another master device.

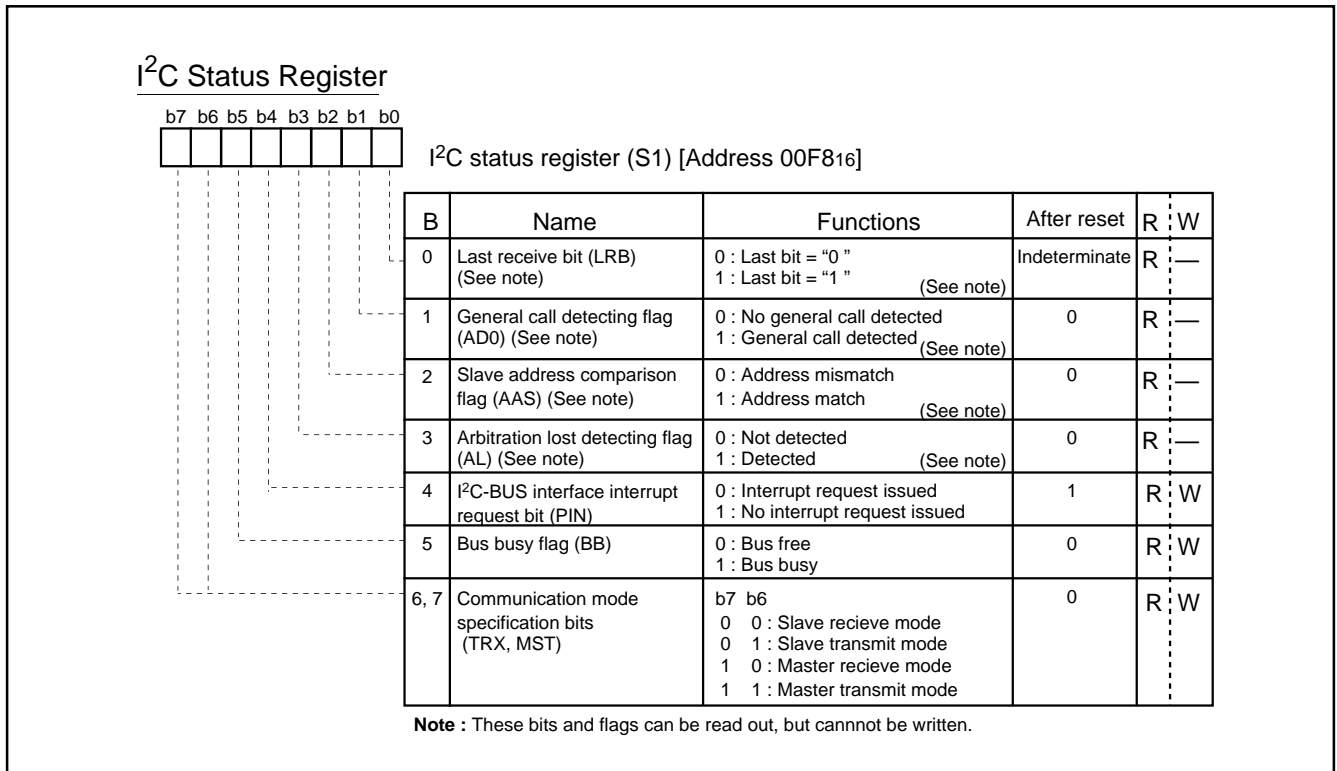

Fig. 8.6.8 I²C Status Register

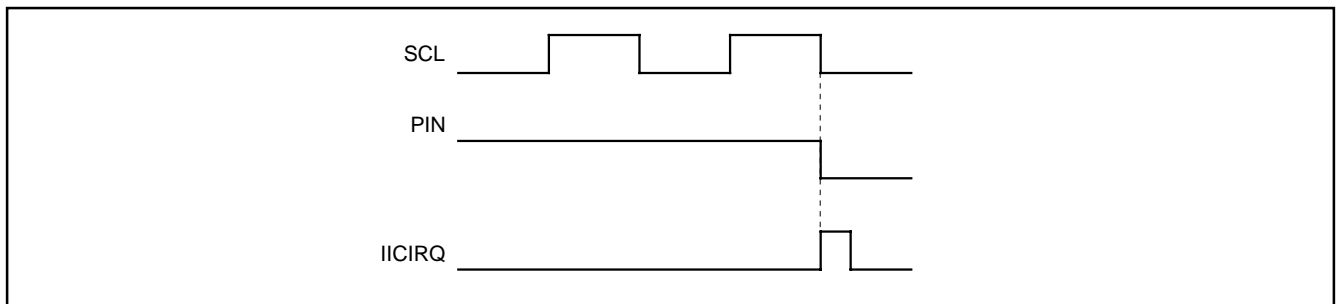

Fig. 8.6.9 Interrupt Request Signal Generation Timing

M37151M6/M8/MA/MC/MF-XXXFP, M37151EFFP

SINGLE-CHIP 8-BIT CMOS MICROCOMPUTER with CLOSED CAPTION DECODER
and ON-SCREEN DISPLAY CONTROLLER

8.6.6 START Condition Generation Method

When the ESO bit of the I²C control register (address 00F9₁₆) is "1," execute a write instruction to the I²C status register (address 00F8₁₆) to set the MST, TRX and BB bits to "1." A START condition will then be generated. After that, the bit counter becomes "000₂" and an SCL is output for 1 byte. The START condition generation timing and BB bit set timing are different in the standard clock mode and the high-speed clock mode. Refer to Figure 8.6.10 for the START condition generation timing diagram, and Table 8.6.2 for the START condition/STOP condition generation timing table.

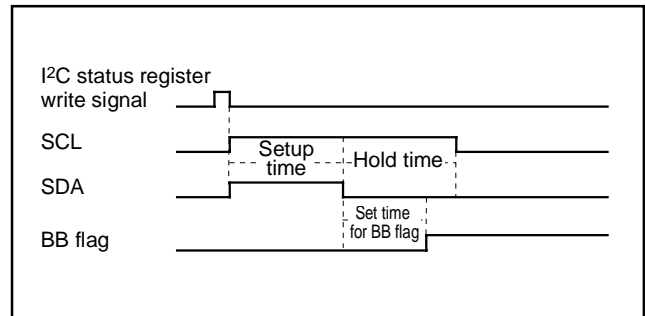

Fig. 8.6.10 START Condition Generation Timing Diagram

8.6.7 STOP Condition Generation Method

When the ESO bit of the I²C control register (address 00F9₁₆) is "1," execute a write instruction to the I²C status register (address 00F8₁₆) to set the MST bit and the TRX bit to "1" and the BB bit to "0". A STOP condition will then be generated. The STOP condition generation timing and the BB flag reset timing are different in the standard clock mode and the high-speed clock mode. Refer to Figure 8.6.11 for the STOP condition generation timing diagram, and Table 8.6.2 for the START condition/STOP condition generation timing table.

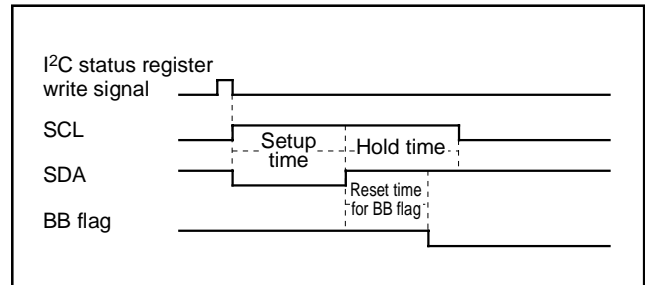

Fig. 8.6.11 STOP Condition Generation Timing Diagram

Table 8.6.2 START Condition/STOP Condition Generation Timing Table

Item	Standard Clock Mode	High-speed Clock Mode
Setup time (START condition)	5.0 μs (20 cycles)	2.5 μs (10 cycles)
Setup time (STOP condition)	4.25 μs (17 cycles)	1.75 μs (7 cycles)
Hold time	5.0 μs (20 cycles)	2.5 μs (10 cycles)
Set/reset time for BB flag	3.0 μs (12 cycles)	1.5 μs (6 cycles)

Note: Absolute time at $\phi = 4$ MHz. The value in parentheses denotes the number of ϕ cycles.

M37151M6/M8/MA/MC/MF-XXXFP, M37151EFP

SINGLE-CHIP 8-BIT CMOS MICROCOMPUTER with CLOSED CAPTION DECODER and ON-SCREEN DISPLAY CONTROLLER

8.6.8 START/STOP Condition Detect Conditions

The START/STOP condition detect conditions are shown in Figure 8.6.12 and Table 8.6.3. Only when the 3 conditions of Table 8.6.3 are satisfied, a START/STOP condition can be detected.

Note: When a STOP condition is detected in the slave mode (MST = 0), an interrupt request signal "IICIRQ" is generated to the CPU.

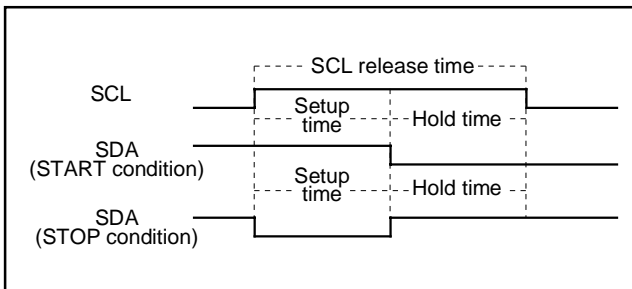

Fig. 8.6.12 START Condition/STOP Condition Detect Timing Diagram

Table 8.6.3 START Condition/STOP Condition Detect Conditions

Standard Clock Mode	High-speed Clock Mode
6.5 μ s (26 cycles) < SCL release time	1.0 μ s (4 cycles) < SCL release time
3.25 μ s (13 cycles) < Setup time	0.5 μ s (2 cycles) < Setup time
3.25 μ s (13 cycles) < Hold time	0.5 μ s (2 cycles) < Hold time

Note: Absolute time at $\phi = 4$ MHz. The value in parentheses denotes the number of ϕ cycles.

8.6.9 Address Data Communication

There are two address data communication formats, namely, 7-bit addressing format and 10-bit addressing format. The respective address communication formats are described below.

(1) 7-bit addressing format

To support the 7-bit addressing format, set the 10BIT SAD bit of the I²C control register (address 00F9₁₆) to "0." The first 7-bit address data transmitted from the master is compared with the high-order 7-bit slave address stored in the I²C address register (address 00F7₁₆). At the time of this comparison, address comparison of the RBW bit of the I²C address register (address 00F7₁₆) is not made. For the data transmission format when the 7-bit addressing format is selected, refer to Figure 8.6.13, (1) and (2).

(2) 10-bit addressing format

To support the 10-bit addressing format, set the 10BIT SAD bit of the I²C control register (address 00F9₁₆) to "1." An address comparison is made between the first-byte address data transmitted from the master and the 7-bit slave address stored in the I²C address register (address 00F7₁₆). At the time of this comparison, an address comparison is performed between the RBW bit of the I²C address register (address 00F7₁₆) and the R/W bit, which is the last bit of the address data transmitted from the master. In the 10-bit addressing mode, the R/W bit not only specifies the direction of communication for control data but is also processed as an address data bit.

When the first-byte address data matches the slave address, the AAS bit of the I²C status register (address 00F8₁₆) is set to "1." After the second-byte address data is stored into the I²C data shift register (address 00F6₁₆), perform an address comparison between the second-byte data and the slave address by software. When the address data of the 2nd byte matches the slave address, set the RBW bit of the I²C address register (address 00F7₁₆) to "1" by software. This processing can match the 7-bit slave address and R/W data, which are received after a RESTART condition is detected, with the value of the I²C address register (address 00F7₁₆). For the data transmission format when the 10-bit addressing format is selected, refer to Figure 8.6.13, (3) and (4).

M37151M6/M8/MA/MC/MF-XXXFP, M37151EFFP

SINGLE-CHIP 8-BIT CMOS MICROCOMPUTER with CLOSED CAPTION DECODER
and ON-SCREEN DISPLAY CONTROLLER

8.6.10 Example of Master Transmission

An example of master transmission in the standard clock mode, at the SCL frequency of 100 kHz with the ACK return mode enabled, is shown below.

- ① Set a slave address in the high-order 7 bits of the I²C address register (address 00F7₁₆) and "0" in the RBW bit.
- ② Set the ACK return mode and SCL = 100 kHz by setting "85₁₆" in the I²C clock control register (address 00FA₁₆).
- ③ Set "10₁₆" in the I²C status register (address 00F8₁₆) and hold the SCL at HIGH.
- ④ Set a communication enable status by setting "48₁₆" in the I²C control register (address 00F9₁₆).
- ⑤ Set the address data of the destination of transmission in the high-order 7 bits of the I²C data shift register (address 00F6₁₆) and set "0" in the least significant bit.
- ⑥ Set "F0₁₆" in the I²C status register (address 00F8₁₆) to generate a START condition. At this time, an SCL for 1 byte and an ACK clock automatically occurs.
- ⑦ Set transmit data in the I²C data shift register (address 00F6₁₆). At this time, an SCL and an ACK clock automatically occurs.
- ⑧ When transmitting control data of more than 1 byte, repeat step ⑦.
- ⑨ Set "D0₁₆" in the I²C status register (address 00F8₁₆). After this, if ACK is not returned or transmission ends, a STOP condition will be generated.

8.6.11 Example of Slave Reception

An example of slave reception in the high-speed clock mode, at the SCL frequency of 400 kHz, with the ACK Non-return mode enabled while using the addressing format, is shown below.

- ① Set a slave address in the high-order 7 bits of the I²C address register (address 00F7₁₆) and "0" in the RBW bit.
- ② Set the ACK non-return mode and SCL = 400 kHz by setting "25₁₆" in the I²C clock control register (address 00FA₁₆).
- ③ Set "10₁₆" in the I²C status register (address 00F8₁₆) and hold the SCL at HIGH.
- ④ Set a communication enable status by setting "48₁₆" in the I²C control register (address 00F9₁₆).
- ⑤ When a START condition is received, an address comparison is executed.
 - ⑥ •When all transmitted address are "0" (general call):
AD0 of the I²C status register (address 00F8₁₆) is set to "1" and an interrupt request signal occurs.
 - When the transmitted addresses match the address set in ①:
ASS of the I²C status register (address 00F8₁₆) is set to "1" and an interrupt request signal occurs.
 - In the cases other than the above:
AD0 and AAS of the I²C status register (address 00F8₁₆) are set to "0" and no interrupt request signal occurs.
- ⑦ Set dummy data in the I²C data shift register (address 00F6₁₆).
- ⑧ When receiving control data of more than 1 byte, repeat step ⑦.
- ⑨ When a STOP condition is detected, the communication ends.

M37151M6/M8/MA/MC/MF-XXXFP, M37151EFP

SINGLE-CHIP 8-BIT CMOS MICROCOMPUTER with CLOSED CAPTION DECODER
and ON-SCREEN DISPLAY CONTROLLER

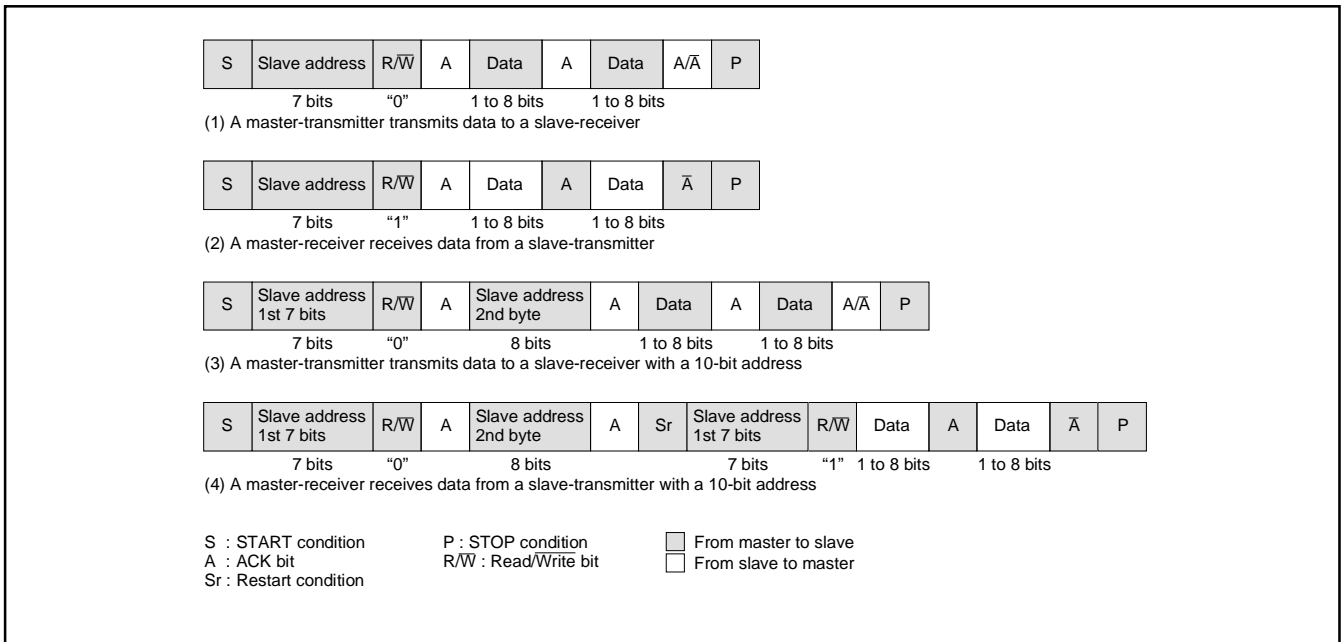

Fig. 8.6.13 Address Data Communication Format

8.6.12 Precautions when using multi-master I²C-BUS interface

(1) Read-modify-write instruction

Precautions for executing the read-modify-write instructions, such as SEB and CLB, is for each register of the multi-master I²C-BUS interface are described below.

- I²C data shift register (S0)
When executing the read-modify-write instruction for this register during transfer, data may become an arbitrary value.
- I²C address register (S0D)
When the read-modify-write instruction is executed for this register at detection of the STOP condition, data may become an arbitrary value because hardware changes the read/write bit (RBW) at the above timing.
- I²C status register (S1)
Do not execute the read-modify-write instruction for this register because all bits of this register are changed by hardware.
- I²C control register (S1D)
When the read-modify-write instruction is executed for this register at detection of the START condition or at completion of the byte transfer, data may become an arbitrary value because hardware changes the bit counter (BC0-BC2) at the above timing.
- I²C clock control register (S2)
The read-modify-write instruction can be executed for this register.

(2) START condition generating procedure using multi-master

① Procedure example (The necessary conditions for the procedure are described in ② to ⑤ below).

```

LDA    —          (Take at slave address value)
SEI    (Interrupt disabled)
BBS    5,S1,BUSBUSY (BB flag confirmation and branch process)

BUSFREE:
STA    S0          (Write slave address value)
LDM    #S0,S1     (Trigger START condition generation)
CLI    (Interrupt enabled)

BUSBUSY:
CLI    (Interrupt enabled)
    
```

- ② Use "STA," "STX" or "STY" of the zero page addressing instruction for writing the slave address value to the I²C data shift register.
- ③ Use "LDM" instruction for setting trigger of START condition generation.
- ④ Write the slave address value of ② and set trigger of START condition generation as in ③ continuously, as shown in the procedure example.
- ⑤ Disable interrupts during the following three process steps:
 - BB flag confirmation
 - Write slave address value
 - Trigger of START condition generation
When the condition of the BB flag is bus busy, enable interrupts immediately.

M37151M6/M8/MA/MC/MF-XXXFP, M37151EFFP

SINGLE-CHIP 8-BIT CMOS MICROCOMPUTER with CLOSED CAPTION DECODER
and ON-SCREEN DISPLAY CONTROLLER

(3) RESTART condition generation procedure

① Procedure example (The necessary conditions for the procedure are described in ② to ⑥ below.)

Execute the following procedure when the PIN bit is "0."

```

      •
      •
LDM  #$00, S1    (Select slave receive mode)
LDA  —          (Take out slave address value)
SEI  —          (Interrupt disabled)
STA  S0         (Write slave address value)
LDM  #$F0, S1   (Trigger RESTART condition generation)
CLI  —          (Interrupt enabled)
      •
      •
    
```

② Select the slave receive mode when the PIN bit is "0." Do not write "1" to the PIN bit. Neither "0" nor "1" is specified for the writing to the BB bit.

The TRX bit becomes "0" and the SDA pin is released.

③ The SCL pin is released by writing the slave address value to the I²C data shift register. Use "STA," "STX" or "STY" of the zero page addressing instruction for writing.

④ Use "LDM" instruction for setting trigger of RESTART condition generation.

⑤ Write the slave address value of ③ and set trigger of RESTART condition generation of ④ continuously, as shown in the procedure example.

⑥ Disable interrupts during the following two process steps:

- Write slave address value
- Trigger RESTART condition generation

(4) STOP condition generating procedure

① Procedure example (The necessary conditions for the procedure are described in ② to ④ below.)

```

      •
      •
SEI  —          (Interrupt disabled)
LDM  #$C0, S1   (Select master transmit mode)
NOP  —          (Set NOP)
LDM  #$D0, S1   (Trigger STOP condition generation)
CLI  —          (Interrupt enabled)
      •
      •
    
```

② Write "0" to the PIN bit when master transmit mode is selected.

③ Execute "NOP" instruction after master transmit mode is set. Also, set trigger of STOP condition generation within 10 cycles after selecting the master transmit mode.

④ Disable interrupts during the following two process steps:

- Select master transmit mode
- Trigger STOP condition generation

(5) Writing to I²C status register

Do not execute an instruction to set the PIN bit to "1" from "0" and an instruction to set the MST and TRX bits to "0" from "1" simultaneously as it may cause the SCL pin the SDA pin to be released after about one machine cycle. Also, do not execute an instruction to set the MST and TRX bits to "0" from "1" when the PIN bit is "1," as it may cause the same problem.

(6) Process after STOP condition generation

Do not write data in the I²C data shift register S0 and the I²C status register S1 until the bus busy flag BB becomes "0" after generating the STOP condition in the master mode. Doing so may cause the STOP condition waveform from being generated normally. Reading the registers does not cause the same problem.

M37151M6/M8/MA/MC/MF-XXXFP, M37151EFPSINGLE-CHIP 8-BIT CMOS MICROCOMPUTER with CLOSED CAPTION DECODER
and ON-SCREEN DISPLAY CONTROLLER**8.7 PWM OUTPUT FUNCTION**

This microcomputer is equipped with five 8-bit PWMs (PWM0–PWM4). PWM0–PWM4 have the same circuit structure, an 8-bit resolution with minimum resolution bit width of $4 \mu\text{s}$ (for $f(X_{IN}) = 8 \text{ MHz}$) and repeat period of $1024 \mu\text{s}$ (for $f(X_{IN}) = 8 \text{ MHz}$).

Figure 8.7.1 shows the PWM block diagram. The PWM timing generating circuit applies individual control signals to PWM0–PWM4 using $f(X_{IN})$ divided by 2 as a reference signal.

8.7.1 Data Setting

When outputting PWM0–PWM4, set 8-bit output data to the PWM i register (i means 0 to 4; addresses 0200 $_{16}$ to 0204 $_{16}$).

8.7.2 Transmitting Data from Register to PWM circuit

Data transfer from the 8-bit PWM register to the 8-bit PWM circuit is executed when writing data to the register.

The signal output from the 8-bit PWM output pin corresponds to the contents of this register.

8.7.3 Operating of 8-bit PWM

The following explains the PWM operation.

First, set bit 0 of PWM mode register 1 (address 0208 $_{16}$) to “0” (at reset, bit 0 is already set to “0” automatically), so that the PWM count source is supplied.

PWM0–PWM4 are also used as pins P0 $_0$ –P0 $_4$. Set the corresponding bits of the port P0 direction register to “1” (output mode). And select each output polarity by bit 3 of PWM mode register 1 (address 0208 $_{16}$). Then, set bits 4 to 0 of PWM mode register 2 (address 0209 $_{16}$) to “1” (PWM output).

The PWM waveform is output from the PWM output pins by setting these registers.

Figure 8.7.2 shows the 8-bit PWM timing. One cycle (T) is composed of 256 (2^8) segments. 8 kinds of pulses, relative to the weight of each bit (bits 0 to 7), are output inside the circuit during 1 cycle. Refer to Figure 8.7.2 (a). The 8-bit PWM outputs a waveform which is the logical sum (OR) of pulses corresponding to the contents of bits 0 to 7 of the 8-bit PWM register. Several examples are shown in Figure 8.7.2 (b). 256 kinds of output (HIGH area: 0/256 to 255/256) are selected by changing the contents of the PWM register. An entirely HIGH section cannot be output, i.e. 256/256.

8.7.4 Output after Reset

At reset, the output of ports P0 $_0$ –P0 $_4$ is in the high-impedance state, and the contents of the PWM register and the PWM circuit are undefined. Note that after reset, the PWM output is undefined until setting the PWM register.

M37151M6/M8/MA/MC/MF-XXXFP, M37151EFFP

SINGLE-CHIP 8-BIT CMOS MICROCOMPUTER with CLOSED CAPTION DECODER
and ON-SCREEN DISPLAY CONTROLLER

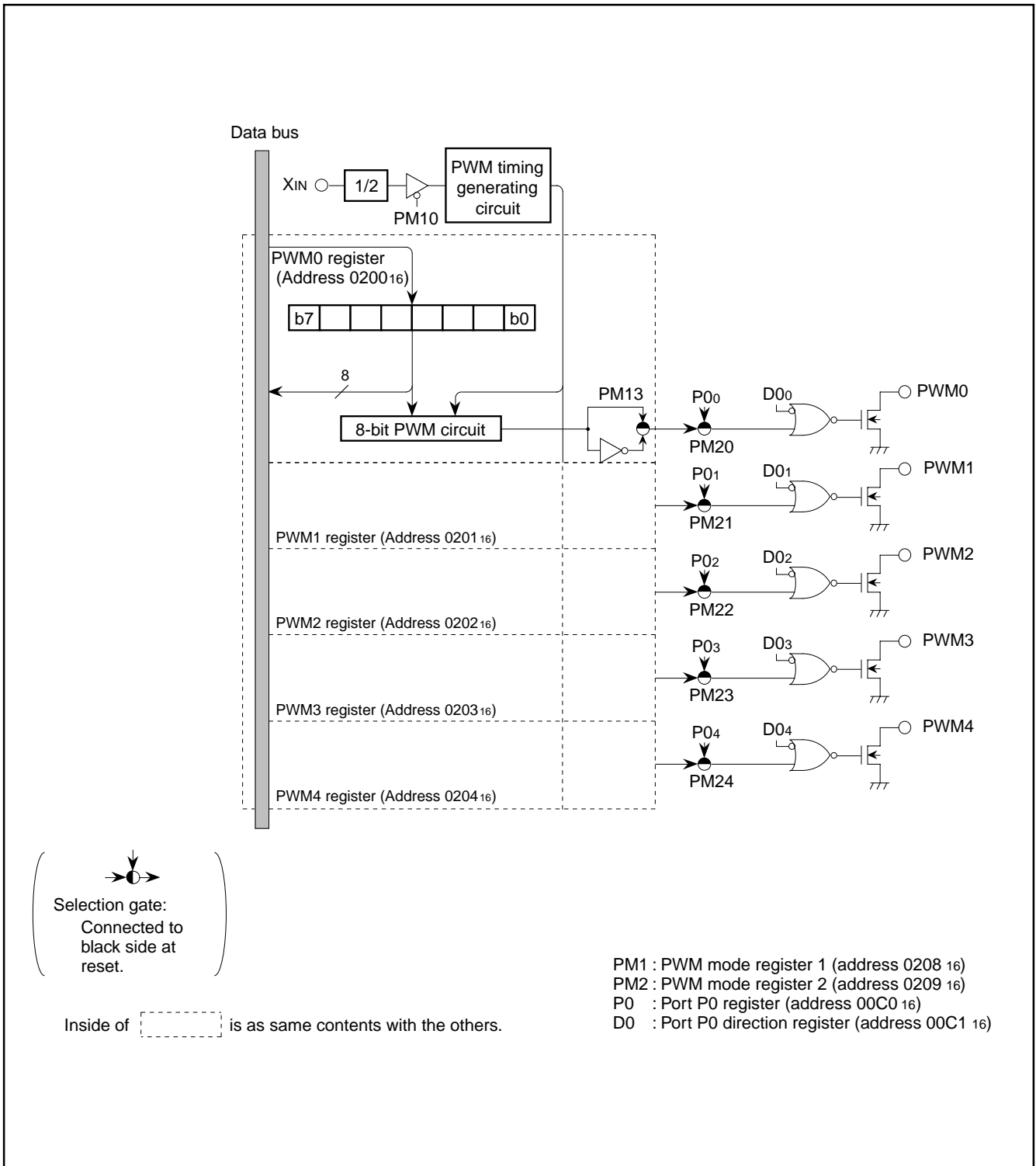

Fig. 8.7.1 PWM Block Diagram

M37151M6/M8/MA/MC/MF-XXXFP, M37151EFP

SINGLE-CHIP 8-BIT CMOS MICROCOMPUTER with CLOSED CAPTION DECODER
and ON-SCREEN DISPLAY CONTROLLER

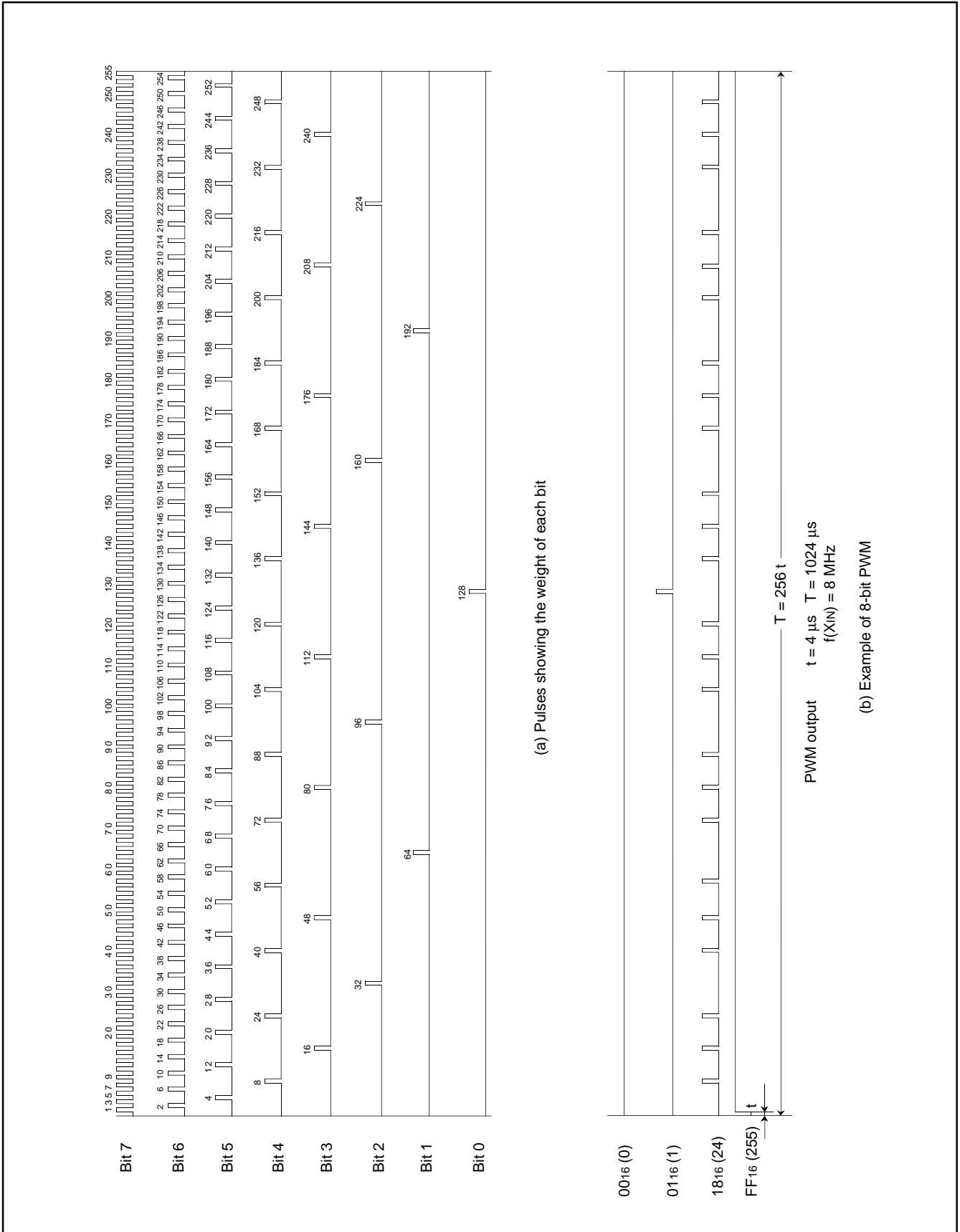

Fig. 8.7.2 PWM Timing

M37151M6/M8/MA/MC/MF-XXXFP, M37151EFP

SINGLE-CHIP 8-BIT CMOS MICROCOMPUTER with CLOSED CAPTION DECODER
and ON-SCREEN DISPLAY CONTROLLER

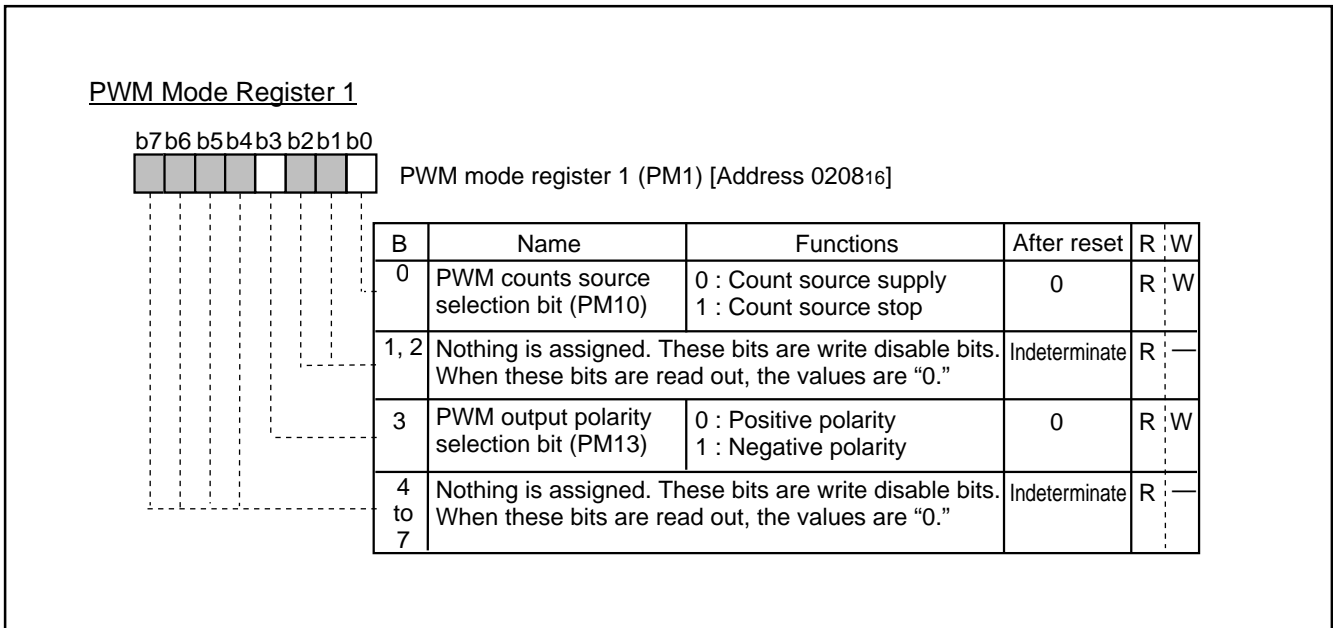

Fig. 8.7.3 PWM Mode Register 1

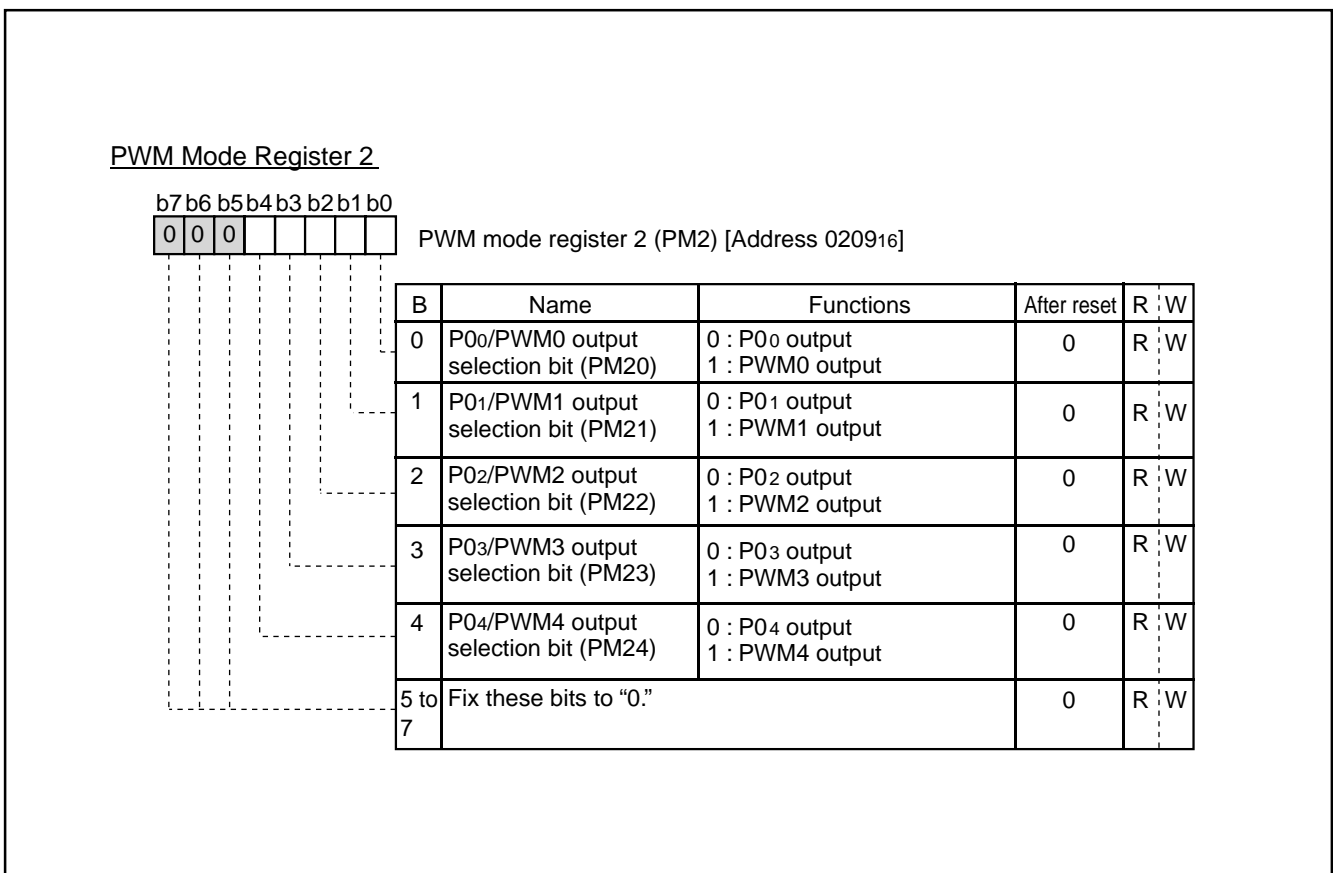

Fig. 8.7.4 PWM Mode Register 2

M37151M6/M8/MA/MC/MF-XXXFP, M37151EFP

SINGLE-CHIP 8-BIT CMOS MICROCOMPUTER with CLOSED CAPTION DECODER
and ON-SCREEN DISPLAY CONTROLLER

8.8 A-D COMPARATOR

The A-D comparator consists of a 7-bit D-A converter and a comparator. The A-D comparator block diagram is shown in Figure 8.8.1.

The reference voltage "V_{ref}" for D-A conversion is set by bits 0 to 6 of A-D control register 2 (address 00ED16).

The comparison result of the analog input voltage and the reference voltage "V_{ref}" is stored in bit 4 of A-D control register 1 (address 00EC16).

For A-D comparison, set "0" to corresponding bits of the direction register to use ports as analog input pins. Write the data to select analog input pins for bits 0 to 2 of A-D control register 1 and write the digital value corresponding to V_{ref} to be compared to bits 0 to 4 of A-D control register 2. The voltage comparison is started by writing to A-D control register 2, and it is completed after 16 machine cycles (NOP instruction X 8).

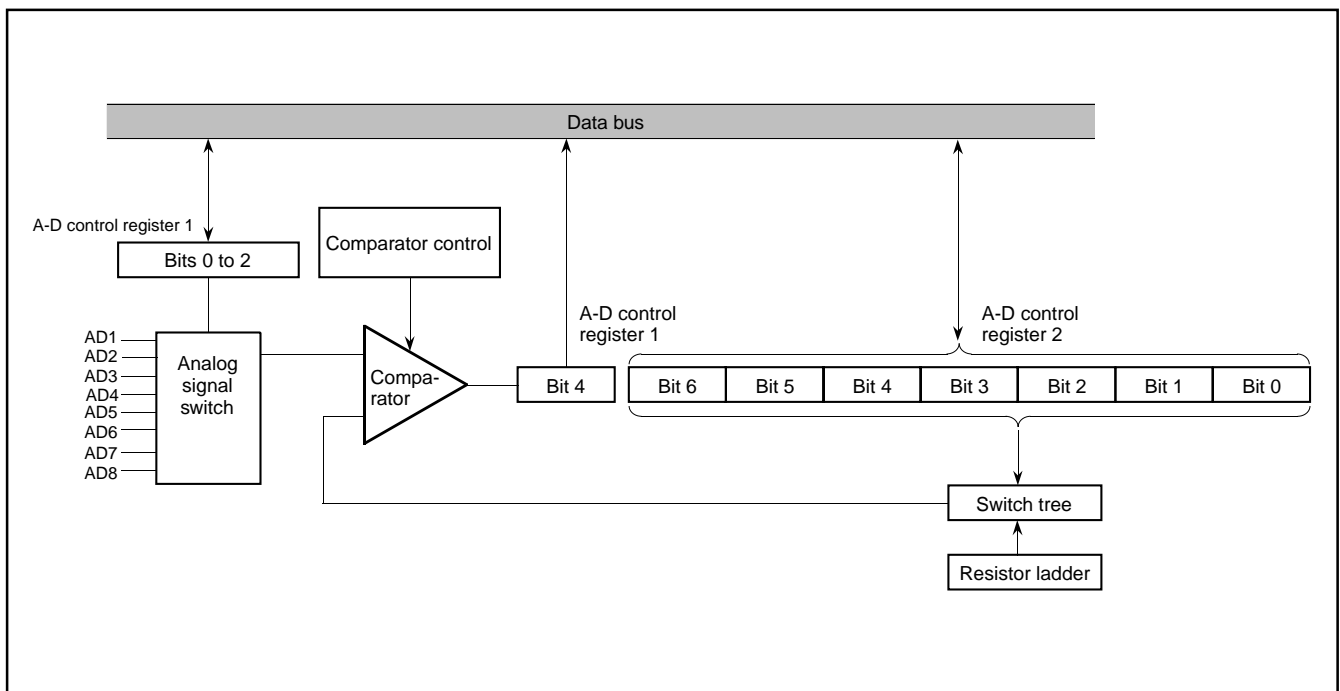

Fig. 8.8.1 A-D Comparator Block Diagram

M37151M6/M8/MA/MC/MF-XXXFP, M37151EFFP

SINGLE-CHIP 8-BIT CMOS MICROCOMPUTER with CLOSED CAPTION DECODER
and ON-SCREEN DISPLAY CONTROLLER

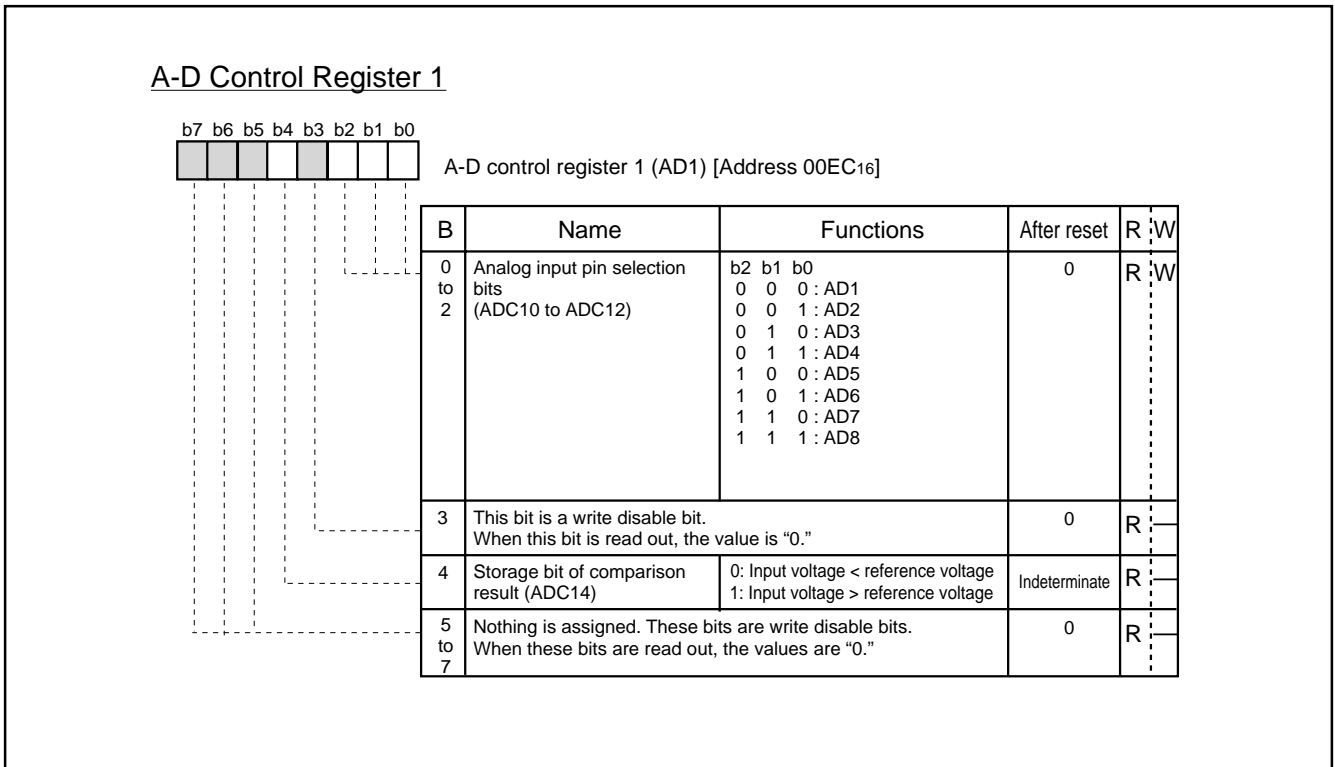

Fig. 8.8.2 A-D Control Register 1

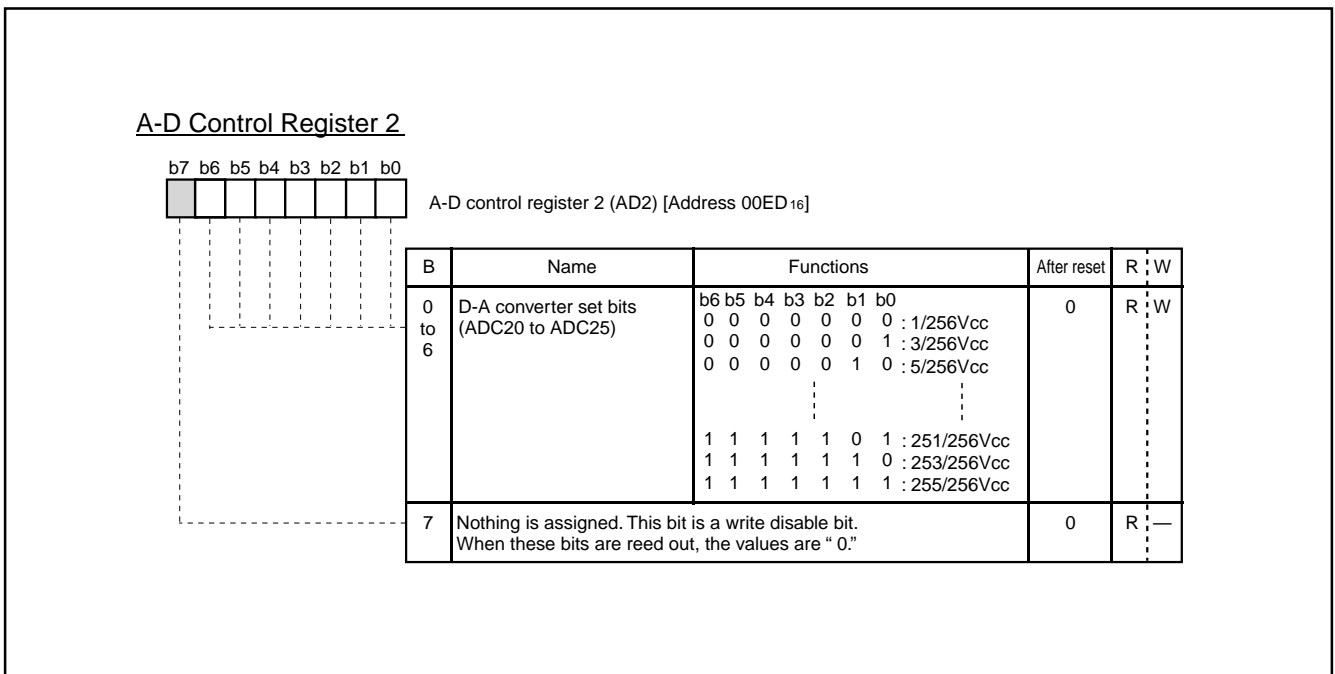

Fig. 8.8.3 A-D Control Register 2

M37151M6/M8/MA/MC/MF-XXXFP, M37151EFP

SINGLE-CHIP 8-BIT CMOS MICROCOMPUTER with CLOSED CAPTION DECODER and ON-SCREEN DISPLAY CONTROLLER

8.9 ROM CORRECTION FUNCTION

This can correct program data in the ROM. Up to 2 addresses can be corrected; a program for correction is stored in the ROM correction vector in the RAM as the top address. There are 2 vectors for ROM correction:.

Vector 1 : address 0300₁₆

Vector 2 : address 0320₁₆

Set the address of the ROM data to be corrected into the ROM correction address register. When the value of the counter matches the ROM data address in the top address of the ROM correction vector, the main program branches to the correction program stored in the ROM memory. To return from the correction program to the main program, the op code and operand of the JMP instruction (total of 3 bytes) are necessary at the end of the correction program.

The ROM correction function is controlled by the ROM correction enable register.

- Notes 1:** Specify the first address (op code address) of each instruction as the ROM correction address.
2: Use the JMP instruction (total of 3 bytes) to return from the correction program to the main program.
3: Do not set the same ROM correction address to both vectors 1 and 2.

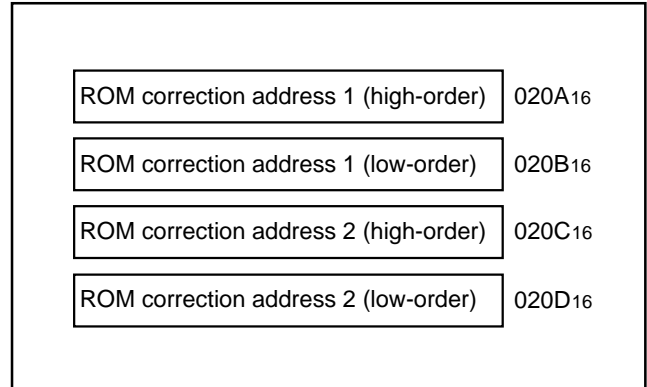
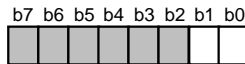

Fig. 8.9.1 ROM Correction Address Registers

ROM Correction Enable Register



ROM correction enable register (RCR) [Address 020E 16]

B	Name	Functions	After reset	R	W
0	Vector 1 enable bit (RC0)	0: Disabled 1: Enabled	0	R	W
1	Vector 2 enable bit (RC1)	0: Disabled 1: Enabled	0	R	W
2 to 7	Nothing is assigned. These bits are write disable bits. When these bits are read out, the values are "0."		0	R	—

M37151M6/M8/MA/MC/MF-XXXFP, M37151EFP

SINGLE-CHIP 8-BIT CMOS MICROCOMPUTER with CLOSED CAPTION DECODER and ON-SCREEN DISPLAY CONTROLLER

8.10 DATA SLICER

This microcomputer includes the data slicer function for the closed caption decoder (referred to as the CCD). This function takes out the caption data superimposed in the vertical blanking interval of a composite video signal. A composite video signal, which makes the sync chip's polarity negative, is input to the CVIN pin.

When the data slicer function is not used, the data slicer circuit and the timing signal generating circuit can be cut off by setting bit 0 of data slicer control register 1 (address 00E0₁₆) to "0." These settings support low-power dissipation.

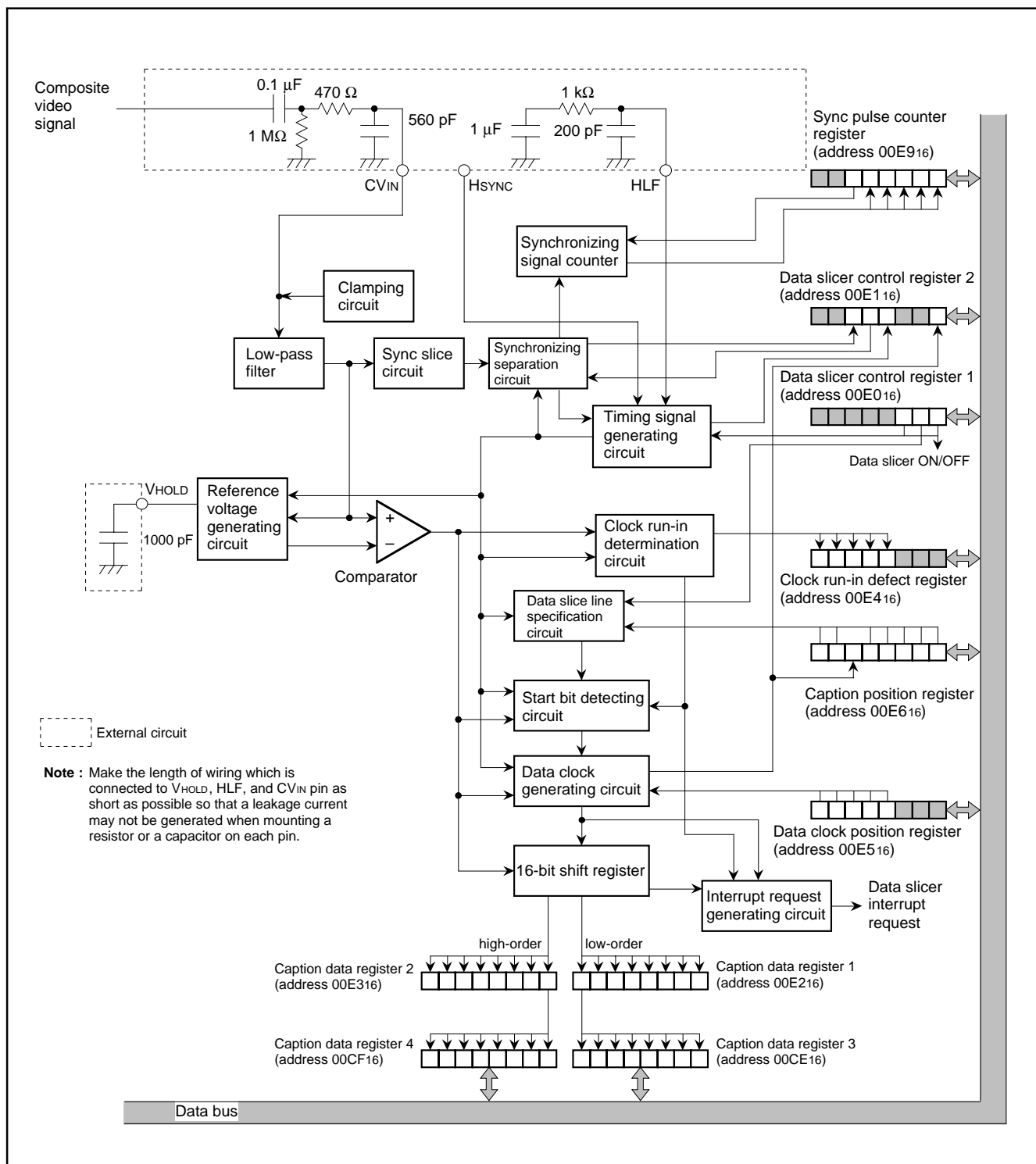

Fig. 8.10.1 Data Slicer Block Diagram

M37151M6/M8/MA/MC/MF-XXXFP, M37151EFP

SINGLE-CHIP 8-BIT CMOS MICROCOMPUTER with CLOSED CAPTION DECODER
and ON-SCREEN DISPLAY CONTROLLER

8.10.1 Notes When not Using Data Slicer

When bit 0 of data slicer control register 1 (address 00E016) is "0," terminate the pins as shown in Figure 8.10.2.

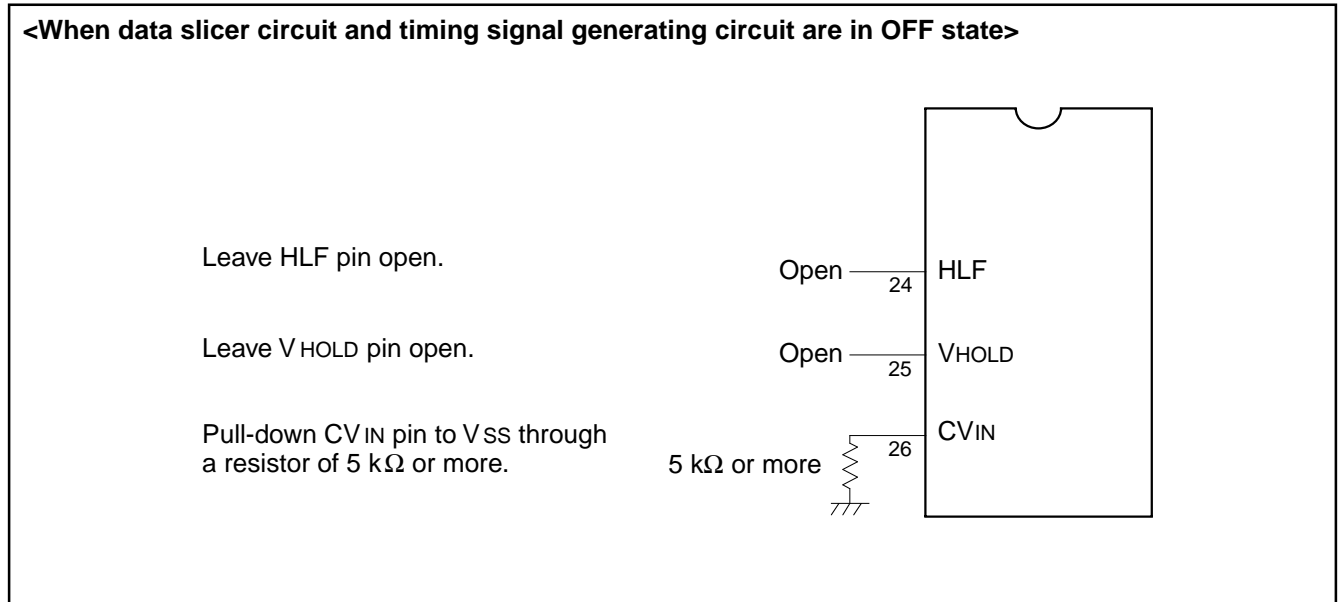

Fig. 8.10.2 Termination of Data Slicer Input/Output Pins when Data Slicer Circuit and Timing Generating Circuit are in OFF State

When both bits 0 and 2 of data slicer control register 1 (address 00E016) are "1," terminate the pins as shown in Figure 8.10.3.

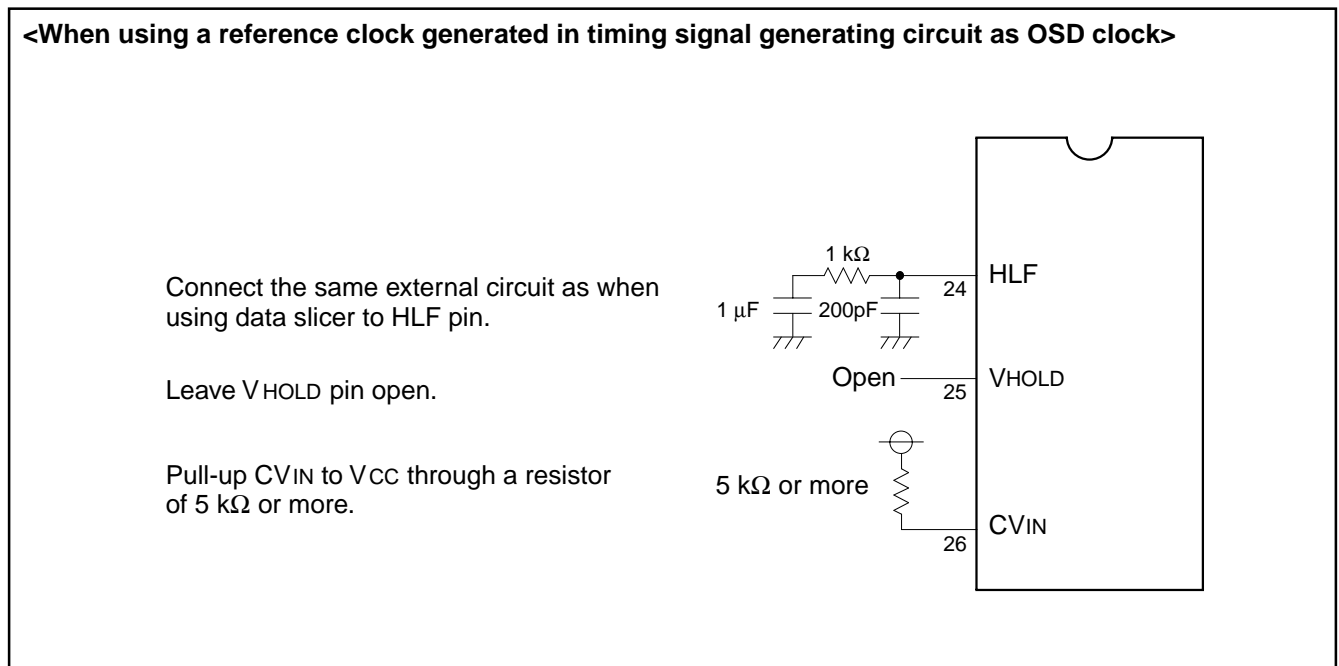

Fig. 8.10.3 Termination of Data Slicer Input/Output Pins when Timing Signal Generating Circuit Is in ON State

M37151M6/M8/MA/MC/MF-XXXFP, M37151EFFP

SINGLE-CHIP 8-BIT CMOS MICROCOMPUTER with CLOSED CAPTION DECODER
and ON-SCREEN DISPLAY CONTROLLER

Figures 8.10.4 and 8.10.5 the data slicer control registers.

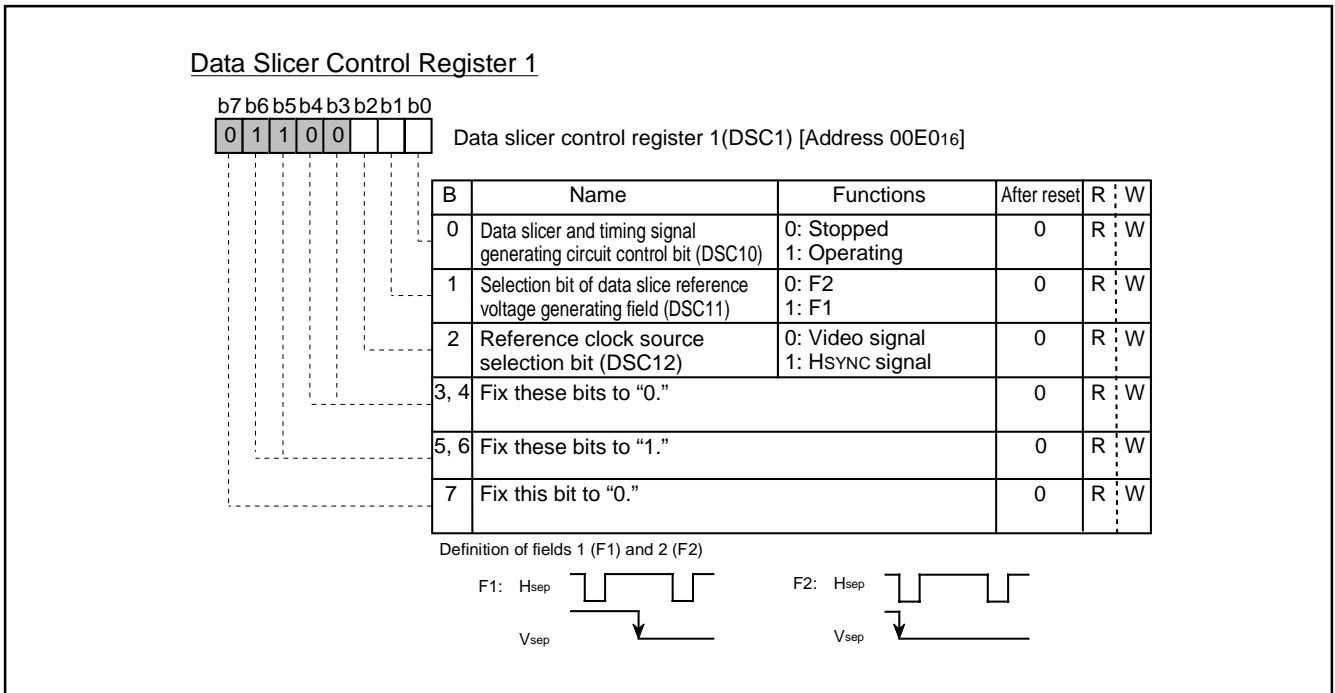

Fig. 8.10.4 Data Slicer Control Register 1

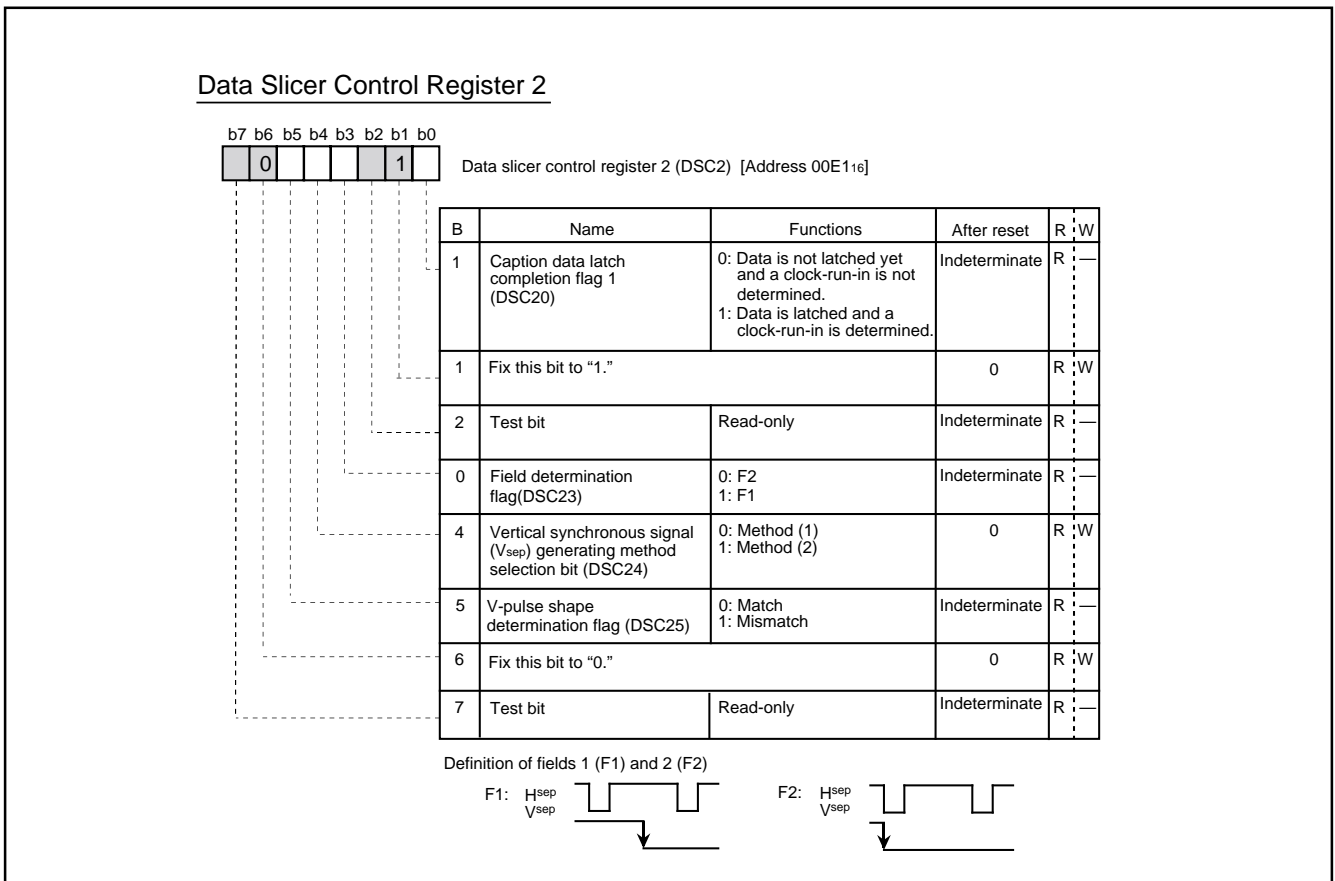

Fig. 8.10.5 Data Slicer Control Register 2

M37151M6/M8/MA/MC/MF-XXXFP, M37151EFP

SINGLE-CHIP 8-BIT CMOS MICROCOMPUTER with CLOSED CAPTION DECODER
and ON-SCREEN DISPLAY CONTROLLER

8.10.2 Clamping Circuit and Low-pass Filter

The clamp circuit clamps the sync chip part of the composite video signal input from the CVIN pin. The low-pass filter attenuates the noise of the clamped composite video signal. The CVIN pin to which composite video signal is input requires an external capacitor (0.1 μ F) coupling. Pull down the CVIN pin with a resistor of hundreds of kilohms to 1 M Ω . In addition, we recommend installing a simple low-pass filter externally, using a resistor and a capacitor at the CVIN pin (refer to Figure 8.10.1).

8.10.3 Sync Slice Circuit

This circuit takes out a composite sync signal from the output signal of the low-pass filter.

8.10.4 Synchronous Signal Separation Circuit

This circuit separates a horizontal synchronous signal and a vertical synchronous signal from the composite sync signal taken out in the sync slice circuit.

(1) Horizontal Synchronous Signal (Hsep)

A one-shot horizontal synchronizing signal Hsep is generated at the falling edge of the composite sync signal.

(2) Vertical Synchronous Signal (Vsep)

As a Vsep signal generating method, it is possible to select one of the following 2 methods by using bit 4 of data slicer control register 2 (address 00E116).

- Method 1 The LOW level width of the composite sync signal is measured. If this width exceeds a certain time, a Vsep signal is generated in synchronization with the rising of the timing signal immediately after this LOW level.
- Method 2 The LOW level width of the composite sync signal is measured. If this width exceeds a certain time, it is detected whether a falling of the composite sync signal exits or not in the LOW level period of the timing signal immediately after this LOW level. If a falling exists, a Vsep signal is generated in synchronization with the rising of the timing signal (refer to Figure 8.10.6).

Figure 8.10.6 shows a Vsep generating timing. The timing signal shown in the figure is generated from the reference clock which the timing generating circuit outputs.

Reading bit 5 of data slicer control register 2 permits determining the shape of the V-pulse portion of the composite sync signal. As shown in Figure 8.10.7, when the A level matches the B level, this bit is "0." In the case of a mismatch, the bit is "1."

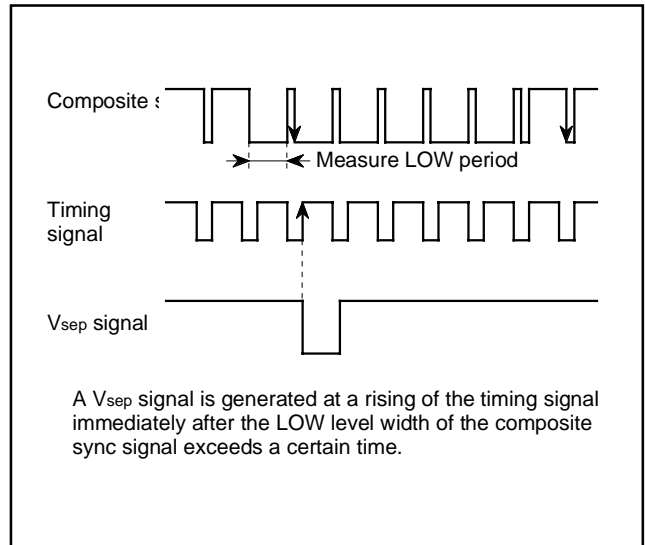

Fig. 8.10.6 Vsep Generating Timing (method 2)

M37151M6/M8/MA/MC/MF-XXXFP, M37151EFFP

SINGLE-CHIP 8-BIT CMOS MICROCOMPUTER with CLOSED CAPTION DECODER
and ON-SCREEN DISPLAY CONTROLLER

8.10.5 Timing Signal Generating Circuit

This circuit generates a reference clock which is 832 times as large as the horizontal synchronous signal frequency. It also generates various timing signals on the basis of the reference clock, horizontal synchronous signal and vertical synchronizing signal. The circuit operates by setting bit 0 of data slicer control register 1 (address 00E016) to "1."

The reference clock can be used as a display clock for the OSD function in addition to the data slicer. The HSYNC signal can be used as a count source instead of the composite sync signal. However, when the HSYNC signal is selected, the data slicer cannot be used. A count source of the reference clock can be selected by bit 2 of data slicer control register 1 (address 00E016).

For pins HLF, connect a resistor and a capacitor as shown in Figure 8.10.1. Make the length of wiring which is connected to these pins as short as possible to prevent a leakage current from being generated.

Note: It takes a few tens of milliseconds until the reference clock becomes stable after the data slicer and the timing signal generating circuit are started. In this period, various timing signals, H_{sep} signals and V_{sep} signals become unstable. For this reason, take stabilization time into consideration when programming.

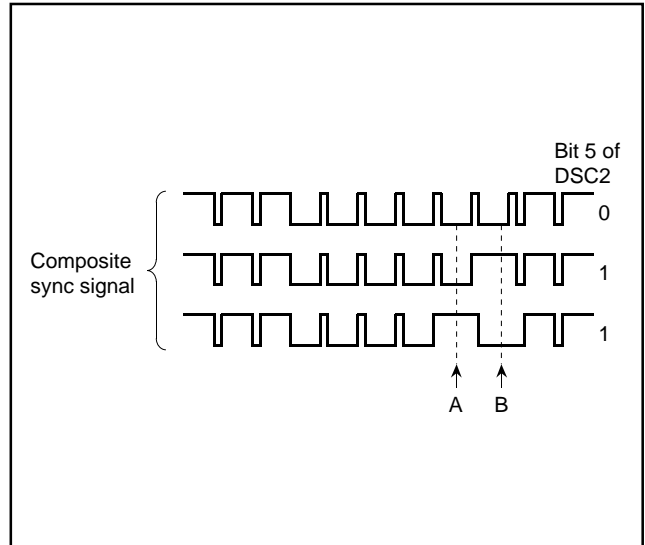

Fig. 8.10.7 Determination of V-pulse Waveform

M37151M6/M8/MA/MC/MF-XXXFP, M37151EFP

SINGLE-CHIP 8-BIT CMOS MICROCOMPUTER with CLOSED CAPTION DECODER and ON-SCREEN DISPLAY CONTROLLER

8.10.6 Data Slice Line Specification Circuit

(1) Specification of data slice line

This circuit determines the lines on to which caption data is superimposed. Data can be sliced for line 21 and one arbitrary line in both field (2 lines total per field). The caption position register (address 00E616) is used for each setting (refer to Table 8.10.1).

The counter is reset at the falling edge of V_{sep} and is incremented by 1 every H_{sep} pulse. When the counter value matches the value specified by bits 4 to 0 of the caption position register, this H_{sep} is sliced.

The values of "0016" to "1F16" can be set in the caption position register (when setting only one arbitrary line). Figure 8.10.8 shows the signals in the vertical blanking interval. Figure 8.10.9 shows the structure of the caption position register.

(3) Field determination

The field determination flag can be read out by bit 3 of data slicer control register 2. This flag changes at the falling edge of V_{sep} .

(2) Specification of line to set slice voltage

Table 8.10.1 shows which field and line generates the reference slice voltage for the clock run-in pulse of each line. The field to generate slice voltage is specified by bit 1 of data slicer control register 1. The line to generate slice voltage for one field is specified by bits 6 and 7 of the caption position register (refer to Table 8.10.1).

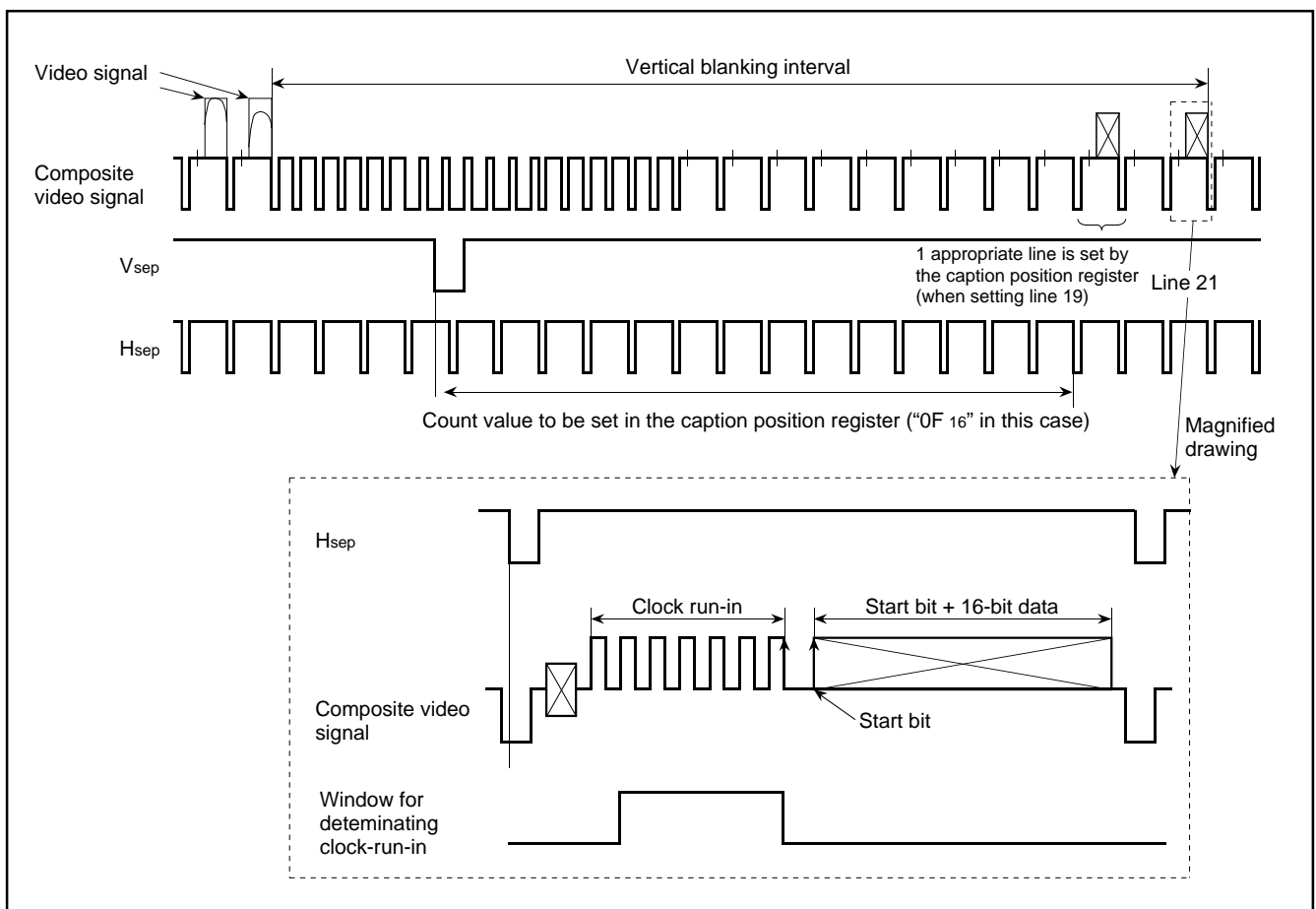

Fig. 8.10.8 Signals in Vertical Blanking Interval

M37151M6/M8/MA/MC/MF-XXXFP, M37151EFFP

SINGLE-CHIP 8-BIT CMOS MICROCOMPUTER with CLOSED CAPTION DECODER
and ON-SCREEN DISPLAY CONTROLLER

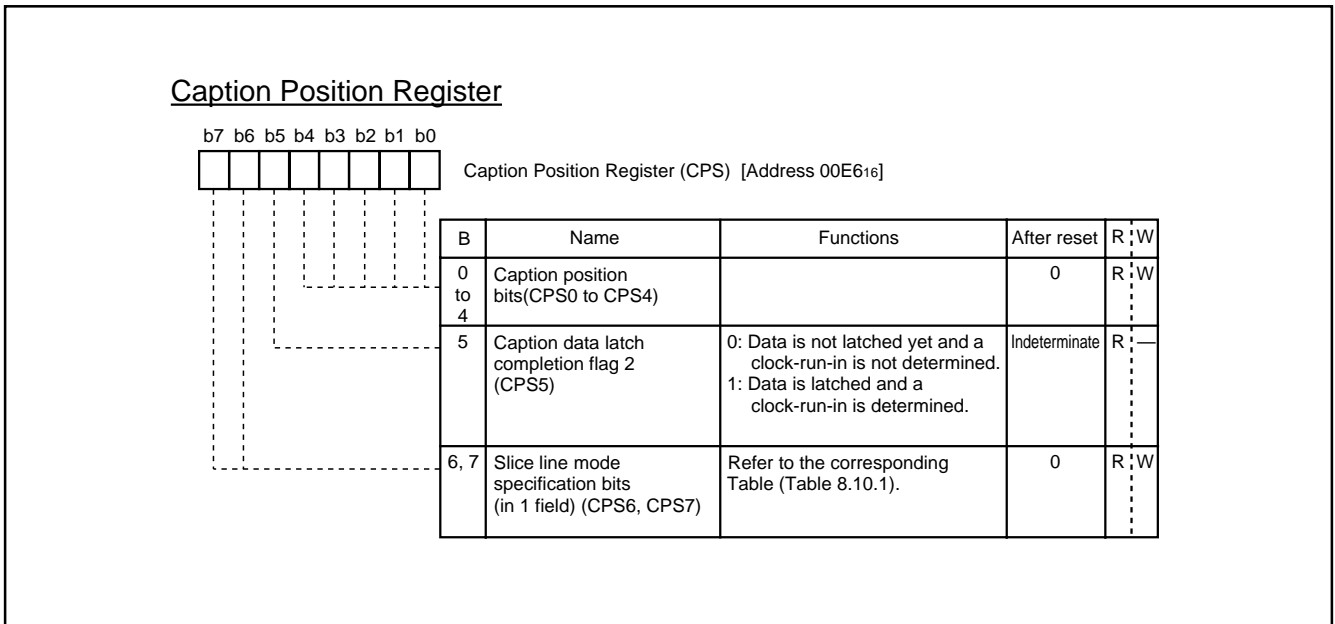

Fig. 8.10.9 Caption Position Register

Table 8.10.1 Specification of Data Slice Line

CPS		Field and Line to Be Sliced Data	Field and Line to Generate Slice Voltage
b7	b6		
0	0	<ul style="list-style-type: none"> Both fields of F1 and F2 Line 21 and a line specified by bits 4 to 0 of CPS (total 2 lines) (See note 2) 	<ul style="list-style-type: none"> Field specified by bit 1 of DSC1 Line 21 (total 1 line)
0	1	<ul style="list-style-type: none"> Both fields of F1 and F2 A line specified by bits 4 to 0 of CPS (total 1 line) (See note 3) 	<ul style="list-style-type: none"> Field specified by bit 1 of DSC1 A line specified by bits 4 to 0 of CPS (total 1 line) (See note 3)
1	0	<ul style="list-style-type: none"> Both fields of F1 and F2 Line 21 (total 1 line) 	<ul style="list-style-type: none"> Field specified by bit 1 of DSC1 Line 21 (total 1 line)
1	1	<ul style="list-style-type: none"> Both fields of F1 and F2 Line 21 and a line specified by bits 4 to 0 of CPS (total 2 lines) (See note 2) 	<ul style="list-style-type: none"> Field specified by bit 1 of DSC1 Line 21 and a line specified by bits 4 to 0 of CPS (total 2 lines) (See note 2)

Notes 1: DSC1 is data slicer control register 1.
CPS is caption position register.
2: Set "00₁₆" to "10₁₆" to bits 4 to 0 of CPS.
3: Set "00₁₆" to "1F₁₆" to bits 4 to 0 of CPS.

M37151M6/M8/MA/MC/MF-XXXFP, M37151EFP

SINGLE-CHIP 8-BIT CMOS MICROCOMPUTER with CLOSED CAPTION DECODER and ON-SCREEN DISPLAY CONTROLLER

8.10.7 Reference Voltage Generating Circuit and Comparator

The composite video signal clamped by the clamping circuit is input to the reference voltage generating circuit and the comparator.

(1) Reference voltage generating circuit

This circuit generates a reference voltage (slice voltage) by using the amplitude of the clock run-in pulse in the line specified by the data slice line specification circuit. Connect a capacitor between the VHOLD pin and the VSS pin, and make the length of wiring as short as possible to prevent a leakage current from being generated.

(2) Comparator

The comparator compares the voltage of the composite video signal with the voltage (reference voltage) generated in the reference voltage generating circuit, and converts the composite video signal into a digital value.

8.10.8 Start Bit Detecting Circuit

This circuit detects a start bit at the line decided in the data slice line specification circuit.

The detection of a start bit is as follows:

- ① A sampling clock is generated by dividing the reference clock output by the timing signal.
- ② A clock run-in pulse is detected by the sampling clock.
- ③ After detection of the pulse, a start bit pattern is detected from the comparator output.

8.10.9 Clock Run-in Determination Circuit

This circuit determinates clock run-in by counting the number of pulses in a window of the composite video signal.

The reference clock count value in one pulse cycle is stored in bits 3 to 7 of the clock run-in detect register (address 00E416). Read out these bits after the occurrence of a data slicer interrupt (refer to "8.10.12 Interrupt Request Generating Circuit").

Figure 8.10.10 shows the structure of the clock run-in detect register.

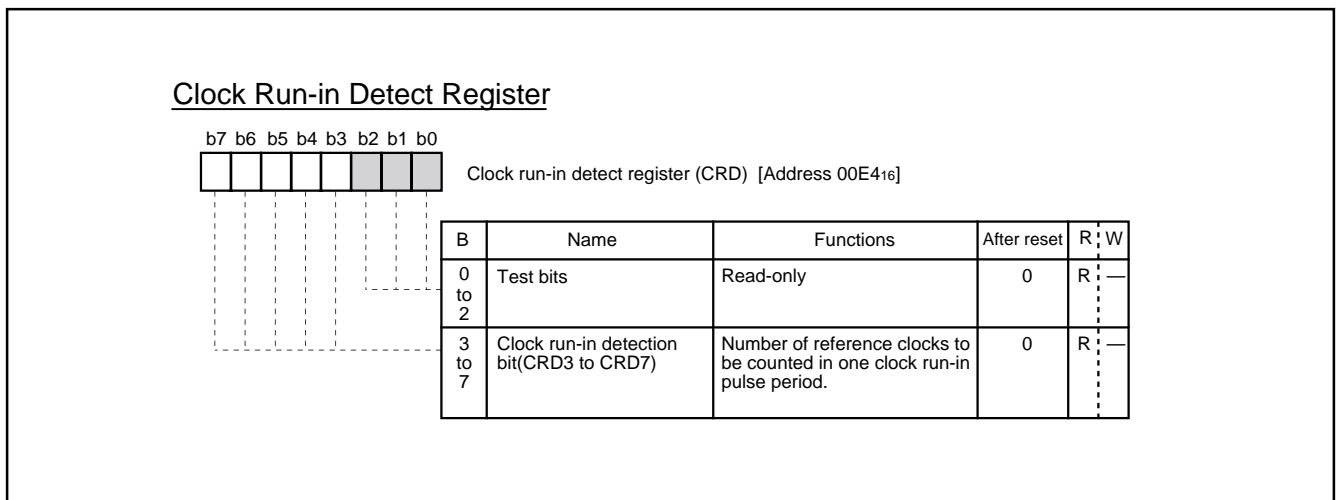

Fig. 8.10.10 Clock Run-in Detect Register

M37151M6/M8/MA/MC/MF-XXXFP, M37151EFFP

SINGLE-CHIP 8-BIT CMOS MICROCOMPUTER with CLOSED CAPTION DECODER
and ON-SCREEN DISPLAY CONTROLLER

8.10.10 Data Clock Generating Circuit

This circuit generates a data clock synchronized with the start bit detected in the start bit detecting circuit. The data clock stores caption data to the 16-bit shift register. When the 16-bit data has been stored and the clock run-in determination circuit determines clock run-in, the caption data latch completion flag is set. This flag is reset at a falling edge of the vertical synchronous signal (V_{sep}).

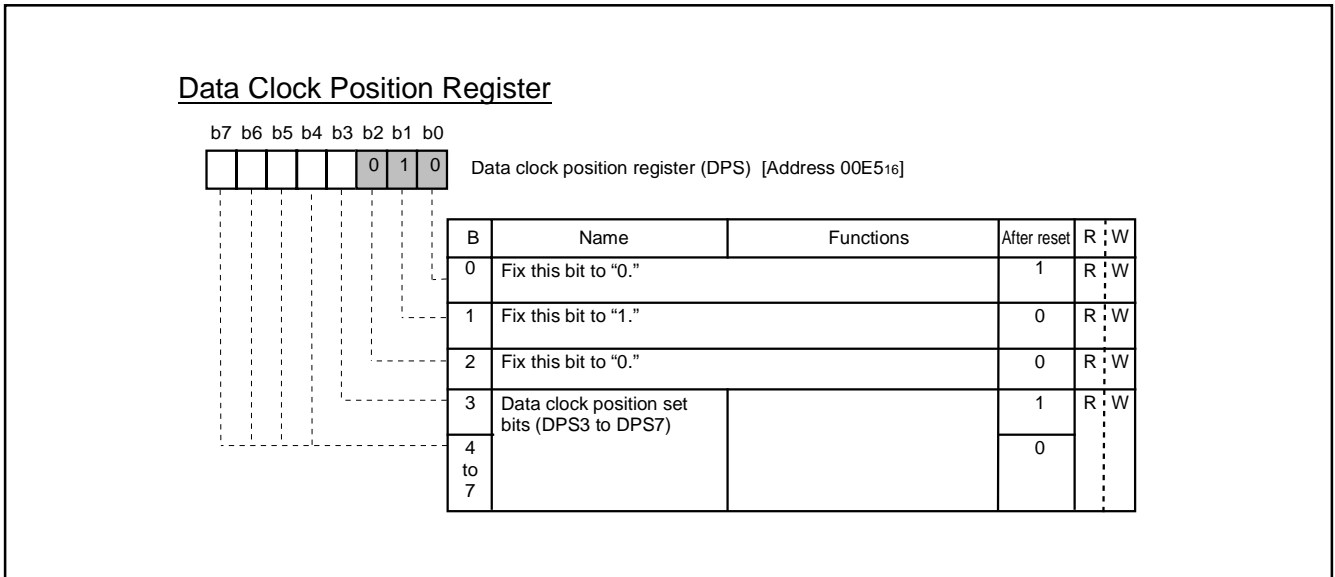

Fig. 8.10.11 Data Clock Position Register

M37151M6/M8/MA/MC/MF-XXXFP, M37151EFP

SINGLE-CHIP 8-BIT CMOS MICROCOMPUTER with CLOSED CAPTION DECODER
and ON-SCREEN DISPLAY CONTROLLER

8.10.11 16-bit Shift Register

The caption data converted into a digital value by the comparator is stored into the 16-bit shift register in synchronization with the data clock. The contents of the high-order 8 bits of the stored caption data can be obtained by reading out data register 2 (address 00E3₁₆) and data register 4 (address 00CF₁₆). The contents of the low-order 8 bits can be obtained by reading out data register 1 (address 00E2₁₆) and data register 3 (address 00CE₁₆), respectively. These registers are reset to "0" at a falling edge of V_{sep}. Read out data registers 1 and 2 after the occurrence of a data slicer interrupt (refer to "8.10.12 Interrupt Request Generating Circuit").

8.10.12 Interrupt Request Generating Circuit

The interrupt requests as shown in Table 8.10.3 are generated by a combination of the following bits; bits 6 and 7 of the caption position register (address 00E6₁₆). Read out the contents of data registers 1 to 4 and the contents of bits 3 to 7 of the clock run-in detect register after the occurrence of a data slicer interrupt request.

Table 8.10.2 Contents of Caption Data Latch Completion Flag and 16-bit Shift Register

Slice Line Specification Mode		Contents of Caption Data Latch Completion Flag		Contents of 16-bit Shift Register	
CPS		Completion Flag 1 (bit 0 of DSC2)	Completion Flag 2 (bit 5 of CPS)	Caption Data Registers 1, 2	Caption Data Registers 3, 4
bit 7	bit 6				
0	0	Line 21	A line specified by bits 4 to 0 of CPS	16-bit data of line 21	16-bit data of a line specified by bits 4 to 0 of CPS
0	1	A line specified by bits 4 to 0 of CPS	Invalid	16-bit data of a line specified by bits 4 to 0 of CPS	Invalid
1	0	Line 21	Invalid	16-bit data of line 21	Invalid
1	1	Line 21	A line specified by bits 4 to 0 of CPS	16-bit data of line 21	16-bit data of a line specified by bits 4 to 0 of CPS

CPS: Caption position register

DSC2: Data slicer control register 2

Table 8.10.3 Occurrence Sources of Interrupt Request

Caption position register		Occurrence Sources of Interrupt Request at End of Data Slice Line
b7	b6	
0	0	After slicing line 21
	1	After a line specified by bits 4 to 0 of CPS
1	0	After slicing line 21
	1	After slicing line 21

M37151M6/M8/MA/MC/MF-XXXFP, M37151EFFP

SINGLE-CHIP 8-BIT CMOS MICROCOMPUTER with CLOSED CAPTION DECODER and ON-SCREEN DISPLAY CONTROLLER

8.10.13 Synchronous Signal Counter

The synchronous signal counter counts the composite sync signal taken out from a video signal in the data slicer circuit or the vertical synchronous signal V_{sep} as a count source.

The count value in a certain time (T time) generated by $f(X_{IN})/2^{13}$ or $f(X_{IN})/2^{13}$ is stored into the 5-bit latch. Accordingly, the latch value changes in the cycle of T time. When the count value exceeds "1F16," "1F16" is stored into the latch.

The latch value can be obtained by reading out the sync pulse counter register (address 00E916). A count source is selected by bit 5 of the sync pulse counter register.

The synchronous signal counter is used when bit 0 of PWM mode register 1 (address 020816) is set to "0."

Figure 8.10.12 shows the structure of the sync pulse counter and Figure 8.10.13 shows the synchronous signal counter block diagram.

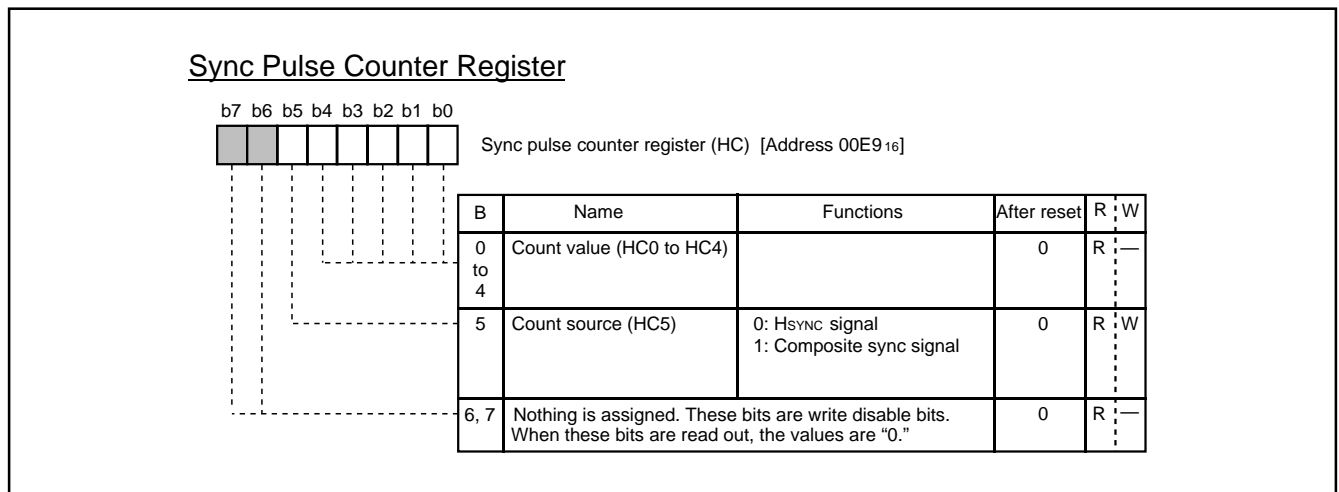

Fig. 8.10.12 Sync Pulse Counter Register

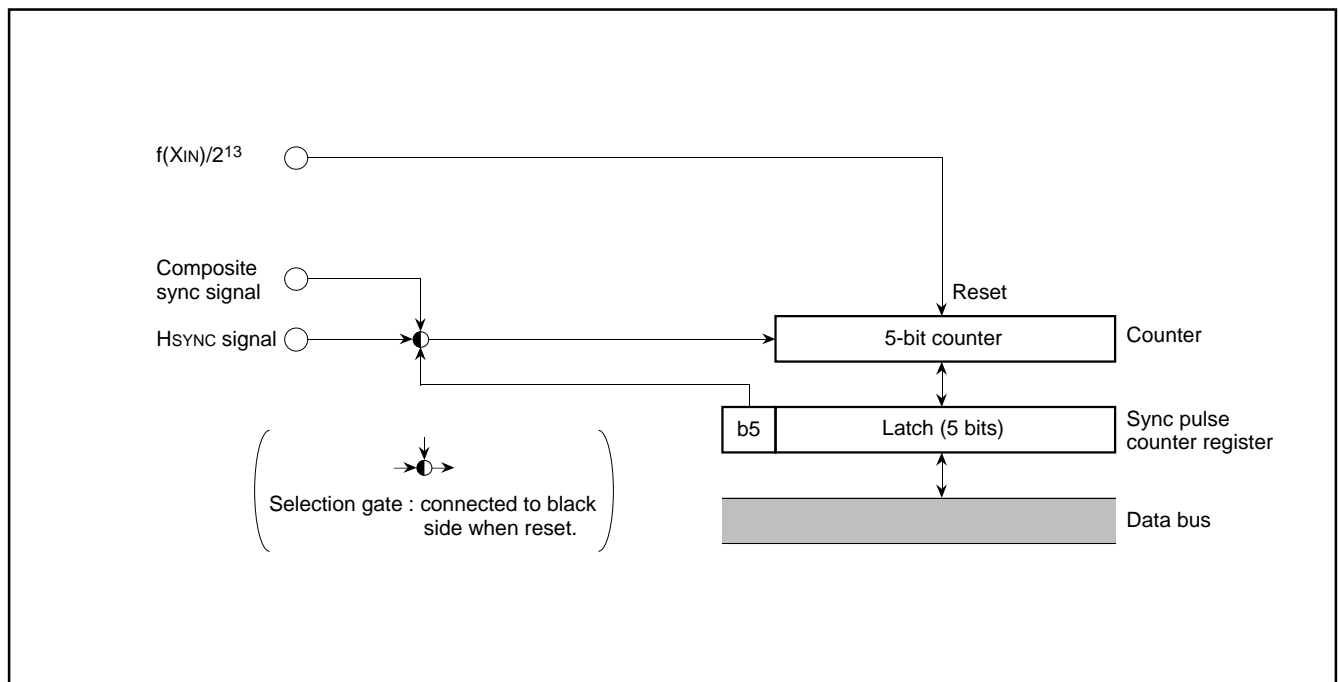

Fig. 8.10.13 Synchronous Signal Counter Block Diagram

M37151M6/M8/MA/MC/MF-XXXFP, M37151EFP

SINGLE-CHIP 8-BIT CMOS MICROCOMPUTER with CLOSED CAPTION DECODER
and ON-SCREEN DISPLAY CONTROLLER

8.11 OSD FUNCTIONS

Table 8.11.1 outlines the OSD functions.

This microcomputer incorporates an OSD circuit of 32 characters X 2 lines. There are also 2 display modes which are selected in block units. The display modes are selected by bits 0 and 1 of block control register i (i = 1 and 2).

The features of each mode are described below.

Table 8.11.1 Features of Each Display Mode

Parameter	Display mode	
	CC mode (Closed caption mode)	OSD mode (Border OFF) (On-screen display mode)
Number of display characters	32 characters X 2 lines	
Dot structure	16 X 26 dots (Character display area : 16 X 20 dots)	16 X 20 dots
Kinds of characters	254 kinds	
Kinds of character sizes	1 kinds	8 kinds
	Pre-divide ratio (See note)	X 2, X 3
	Dot size	1Tc X 1/2H, 1Tc X 1H, 2Tc X 2H, 3Tc X 3H
Attribute	Smooth italic, under line, flash	Border (black)
Character font coloring	1 screen : 8 kinds (per character unit)	
Character background coloring	_____	1 screen : 8 kinds (per character unit)
OSD output	R, G, B	
Raster coloring	Possible (per character unit)	
Function	Auto solid space function	_____
	Window function	_____
Display position	Horizontal: 128 levels, Vertical: 512 levels	
Display expansion (multiline display)	Possible	

Notes 1: The divide ratio of the frequency divider (the pre-divide circuit) is referred as "pre-divide ratio" hereafter.

2: The character size is specified with dot size and pre-divide ratio (refer to 8.11.2 Dot Size).

M37151M6/M8/MA/MC/MF-XXXFP, M37151EFFP

SINGLE-CHIP 8-BIT CMOS MICROCOMPUTER with CLOSED CAPTION DECODER and ON-SCREEN DISPLAY CONTROLLER

The OSD circuit has an extended display mode. This mode allows multiple lines (3 lines or more) to be displayed on the screen by interrupting the display each time one line is displayed and rewriting data in the block for which display has been terminated by software.

Figure 8.11.1 shows the configuration of an OSD character. Figure 8.11.2 shows the block diagram of the OSD circuit. Figure 8.11.3 shows the OSD control register. Figure 8.11.4 shows block control register i.

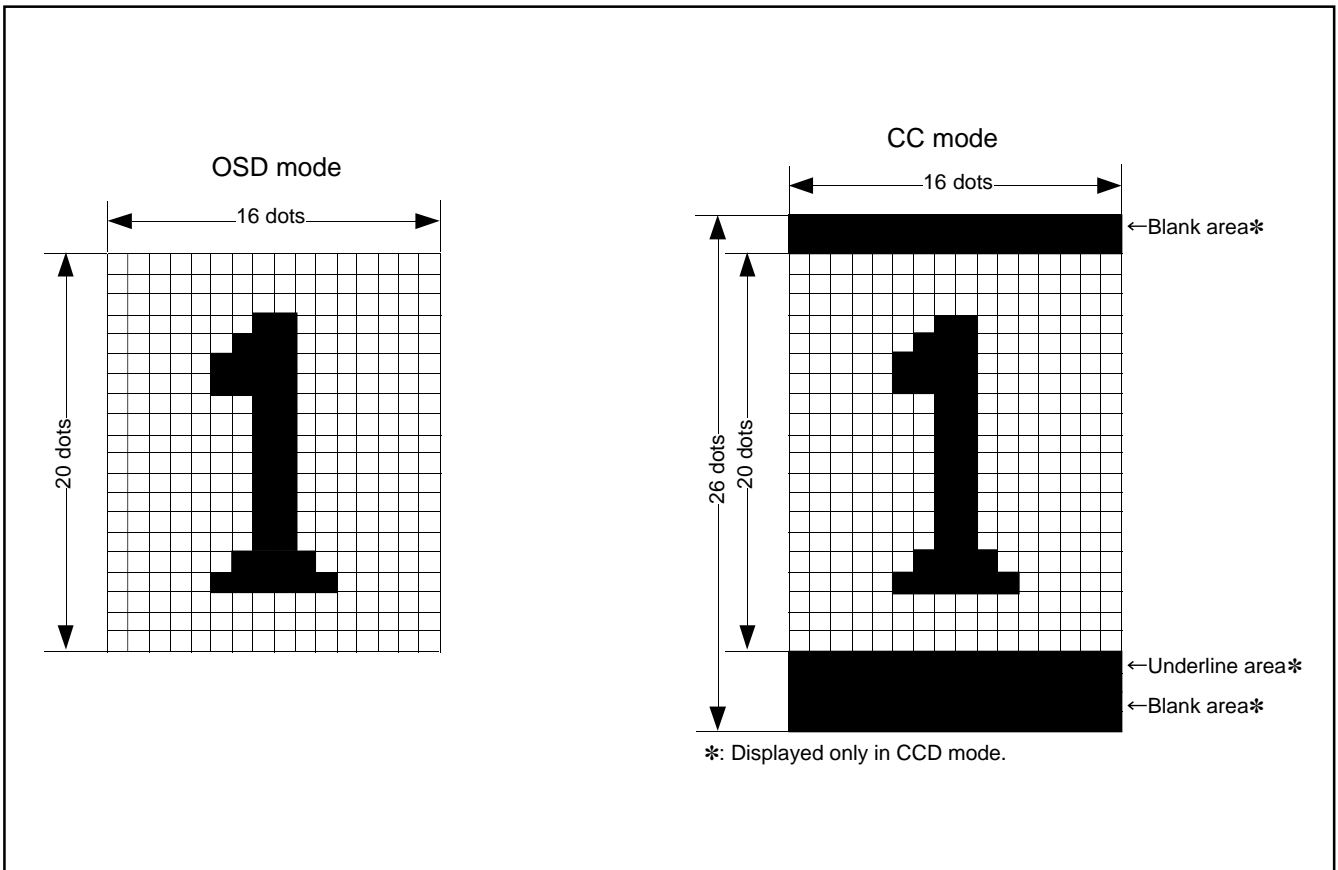

Fig. 8.11.1 Configuration of OSD Character Display Area

M37151M6/M8/MA/MC/MF-XXXFP, M37151EFP

SINGLE-CHIP 8-BIT CMOS MICROCOMPUTER with CLOSED CAPTION DECODER and ON-SCREEN DISPLAY CONTROLLER

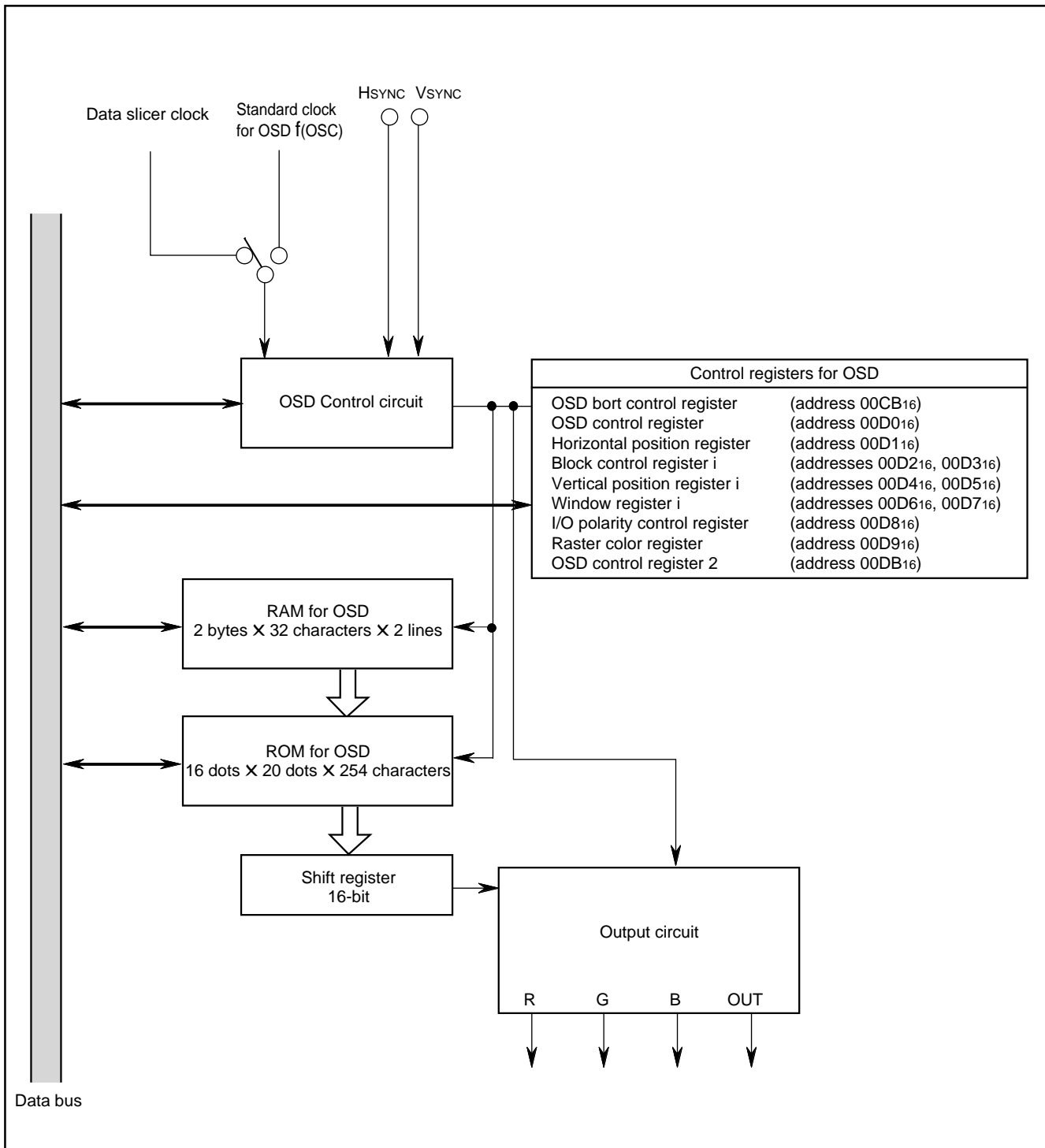
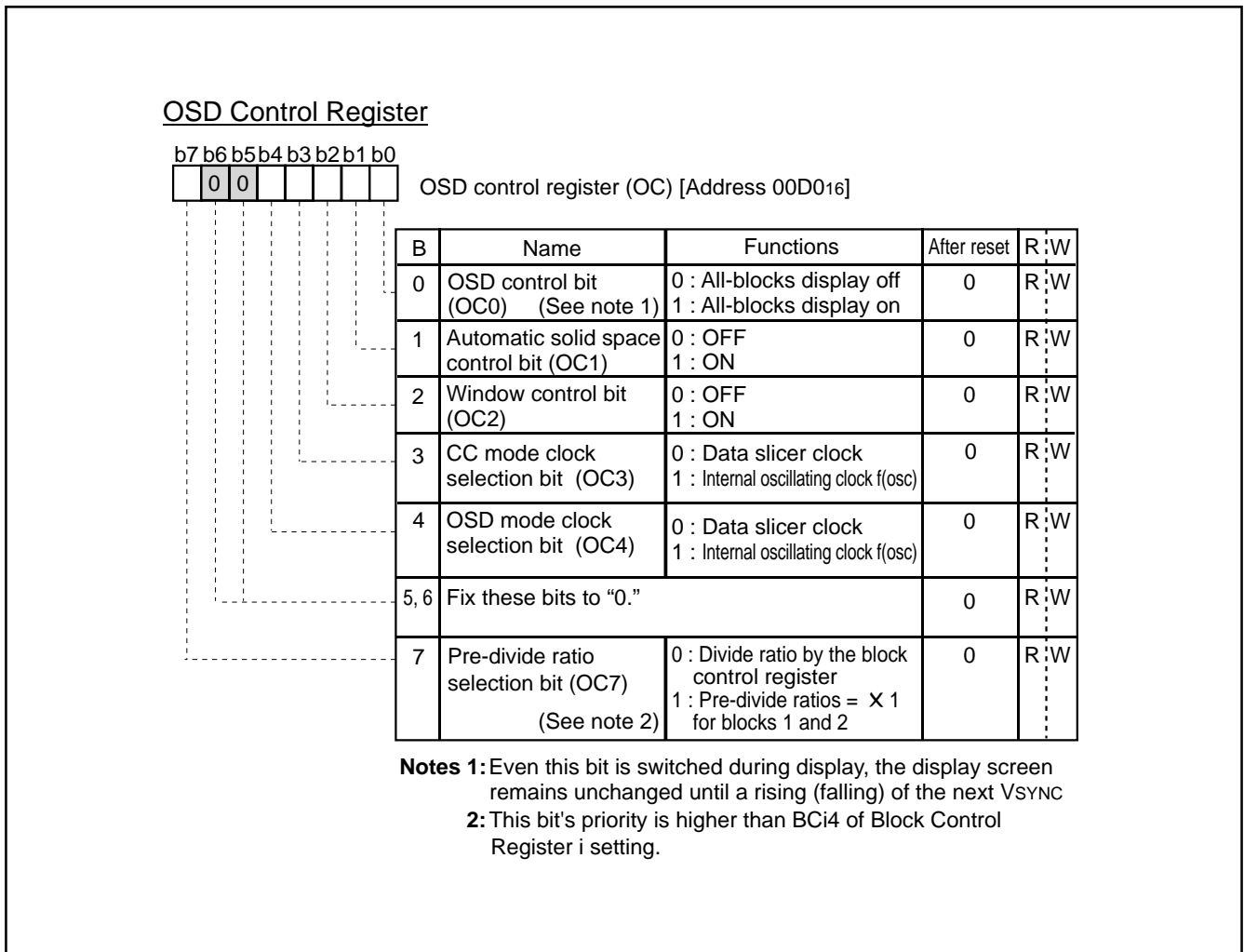

Fig. 8.11.2 Block Diagram of OSD Circuit

M37151M6/M8/MA/MC/MF-XXXFP, M37151EFFP

SINGLE-CHIP 8-BIT CMOS MICROCOMPUTER with CLOSED CAPTION DECODER
and ON-SCREEN DISPLAY CONTROLLER



- Notes** 1: Even this bit is switched during display, the display screen remains unchanged until a rising (falling) of the next VSYNC
2: This bit's priority is higher than BCi4 of Block Control Register i setting.

Fig. 8.11.3 OSD Control Register

M37151M6/M8/MA/MC/MF-XXXFP, M37151EFP

SINGLE-CHIP 8-BIT CMOS MICROCOMPUTER with CLOSED CAPTION DECODER
and ON-SCREEN DISPLAY CONTROLLER

Block Control register i

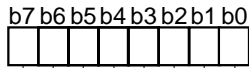

Block control register i (BCi) (i=1, 2) [Addresses 00D216 and 00D316]

B	Name	Functions	After reset	R	W																			
0, 1	Display mode selection bits (BCi0, BCi1) (See note 1)	b1 b0 0 0: Display OFF 0 1: CC mode 1 0: OSD mode (Border OFF) 1 1: OSD mode (Border ON)	Indeterminate	R	W																			
2, 3	Dot size selection bits (BCi2, BCi3)	<table border="1"> <thead> <tr> <th>b4</th> <th>b3</th> <th>b2</th> <th>Pre-divide Ratio</th> <th>Dot Size</th> </tr> </thead> <tbody> <tr> <td rowspan="4">0</td> <td>0</td> <td>0</td> <td rowspan="4">x 2</td> <td>1Tc x 1/2H</td> </tr> <tr> <td>0</td> <td>1</td> <td>1Tc x 1H</td> </tr> <tr> <td>1</td> <td>0</td> <td>2Tc x 2H</td> </tr> <tr> <td>1</td> <td>1</td> <td>3Tc x 3H</td> </tr> </tbody> </table>	b4	b3	b2	Pre-divide Ratio	Dot Size	0	0	0	x 2	1Tc x 1/2H	0	1	1Tc x 1H	1	0	2Tc x 2H	1	1	3Tc x 3H	Indeterminate	R	W
b4	b3	b2	Pre-divide Ratio	Dot Size																				
0	0	0	x 2	1Tc x 1/2H																				
	0	1		1Tc x 1H																				
	1	0		2Tc x 2H																				
	1	1		3Tc x 3H																				
4	Pre-divide ratio selection bit (BCi4)	<table border="1"> <thead> <tr> <th>b4</th> <th>b3</th> <th>b2</th> <th>Pre-divide Ratio</th> <th>Dot Size</th> </tr> </thead> <tbody> <tr> <td rowspan="4">1</td> <td>0</td> <td>0</td> <td rowspan="4">x 3</td> <td>1Tc x 1/2H</td> </tr> <tr> <td>0</td> <td>1</td> <td>1Tc x 1H</td> </tr> <tr> <td>1</td> <td>0</td> <td>2Tc x 2H</td> </tr> <tr> <td>1</td> <td>1</td> <td>3Tc x 3H</td> </tr> </tbody> </table>	b4	b3	b2	Pre-divide Ratio	Dot Size	1	0	0	x 3	1Tc x 1/2H	0	1	1Tc x 1H	1	0	2Tc x 2H	1	1	3Tc x 3H	Indeterminate	R	W
b4	b3	b2	Pre-divide Ratio	Dot Size																				
1	0	0	x 3	1Tc x 1/2H																				
	0	1		1Tc x 1H																				
	1	0		2Tc x 2H																				
	1	1		3Tc x 3H																				
5	Output control bit (BCi5)	0: 2 value output control 1: 3 value output control (notes 3)	Indeterminate	R	W																			
6	Vertical display start position control bit (BCi6)	BC16: Block 1 BC26: Block 1	Indeterminate	R	W																			
7	Window top/bottom boundary control bit (BCi7)	BC17: Window top boundary BC27: Window bottom boundary	Indeterminate	R	W																			

Notes 1: Tc is OSD clock cycle divided in pre-divide circuit.
2: H is Hsync.
3: Refer to the corresponding figure 8.11.18.

Fig. 8.11.4 Block Control Register i

M37151M6/M8/MA/MC/MF-XXXFP, M37151EFFP

SINGLE-CHIP 8-BIT CMOS MICROCOMPUTER with CLOSED CAPTION DECODER and ON-SCREEN DISPLAY CONTROLLER

8.11.1 Display Position

The display positions of characters are specified in units called "blocks." There are 2 blocks: blocks 1 and 2. Up to 32 characters can be displayed in each block (refer to "8.11.5 Memory for OSD").

The display position of each block can be set in both horizontal and vertical directions by software.

The display start position in the horizontal direction can be selected for all blocks from 128-step display positions in units of 4Tosc (Tosc = OSD oscillation cycle).

The display start position in the vertical direction for each block can be selected from 512-step display positions in units of 1 TH (TH = HSYNC cycle).

Blocks are displayed in conformance with the following rules:

- When the display position of block 1 is overlapped with that of block 2 (Figure 8.11.5 (b)), block 1 is displayed in front.
- When another block display position appears while one block is displayed (Figure 8.11.5 (c)), the block with a larger set value as the vertical display start position is displayed.

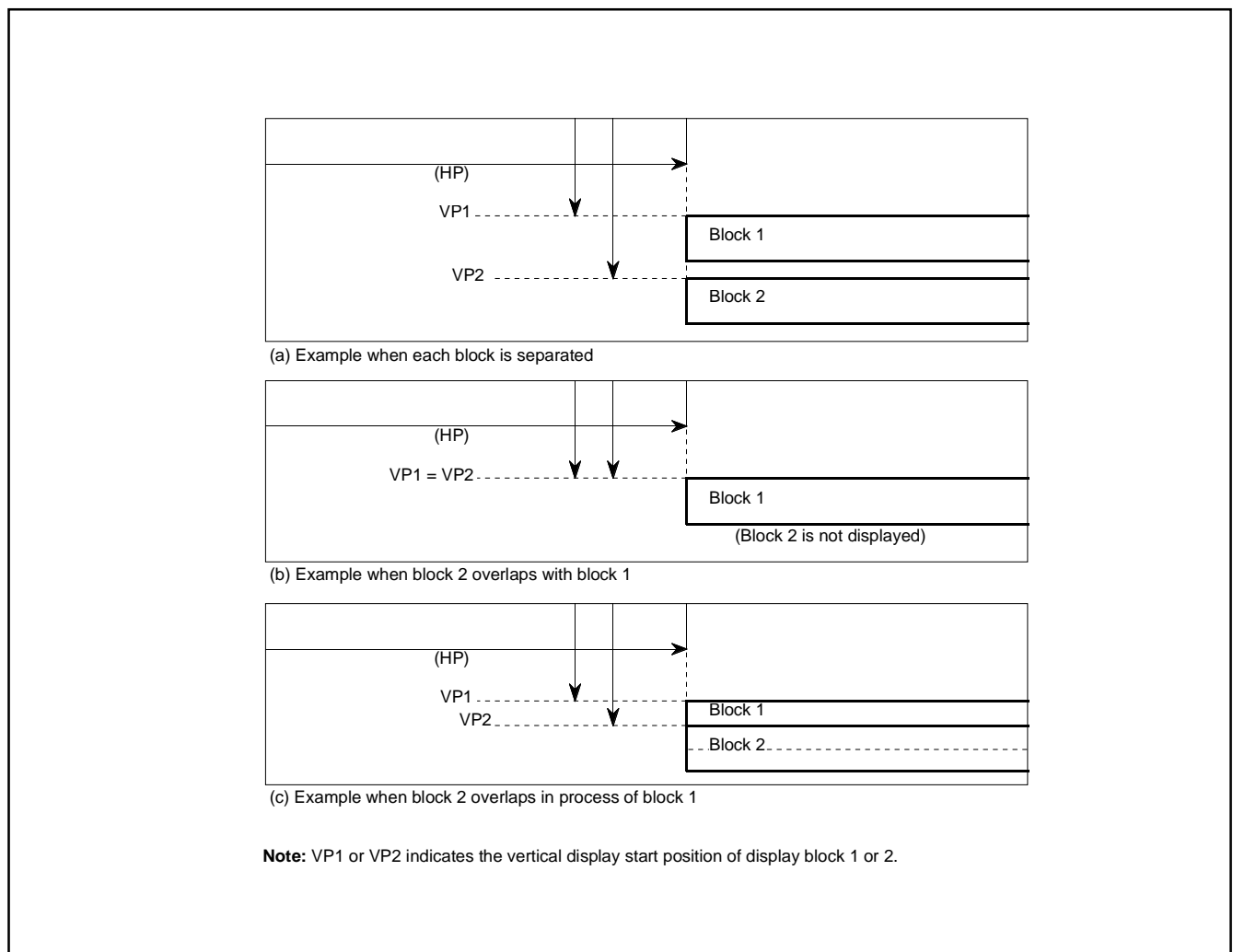

Fig. 8.11.5 Display Position

M37151M6/M8/MA/MC/MF-XXXFP, M37151EFP

SINGLE-CHIP 8-BIT CMOS MICROCOMPUTER with CLOSED CAPTION DECODER
and ON-SCREEN DISPLAY CONTROLLER

The vertical display start position is determined by counting the horizontal sync signal (HSYNC). At this time, when VSYNC and HSYNC are positive polarity (negative polarity), the count starts at the rising edge (falling edge) of HSYNC signal after the fixed cycle of the rising edge (falling edge) of VSYNC signal. So the interval from the rising edge (falling edge) of VSYNC signal to rising edge (falling edge) of HSYNC signal needs enough time (2 machine cycles or more) to avoid jitters. The polarity of HSYNC and VSYNC signals can be select with the I/O polarity control register (address 00D816).

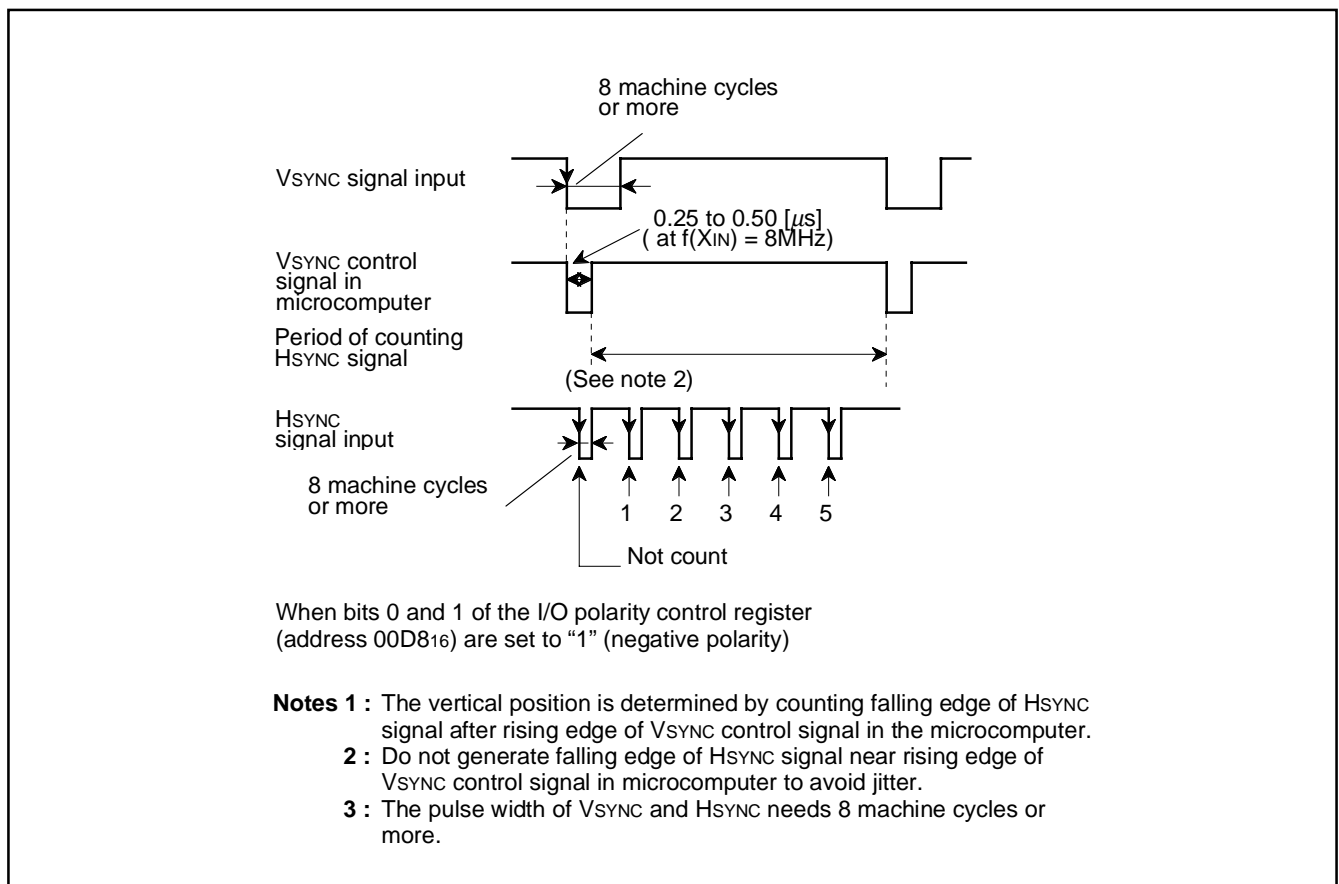

Fig. 8.11.6 Supplement Explanation for Display Position

M37151M6/M8/MA/MC/MF-XXXFP, M37151EFFP

SINGLE-CHIP 8-BIT CMOS MICROCOMPUTER with CLOSED CAPTION DECODER
and ON-SCREEN DISPLAY CONTROLLER

The vertical display start position for each block can be set in 512 steps (where each step is 1TH (TH: HSYNC cycle)) as values "0016" to "FF16" in vertical position register i (i = 1 and 2) (addresses 00D416 and 00D516) and values "0" or "1" in bit 6 of block control register i (i = 1 and 2) (addresses 00D216 and 00D316). The vertical position register is shown in Figure 8.11.7.

The vertical display start position of both blocks can be switched in each step to 1TH or 2TH by setting values "0" or "1" in bit 1 of OSD control register 2 (address 00DB16).

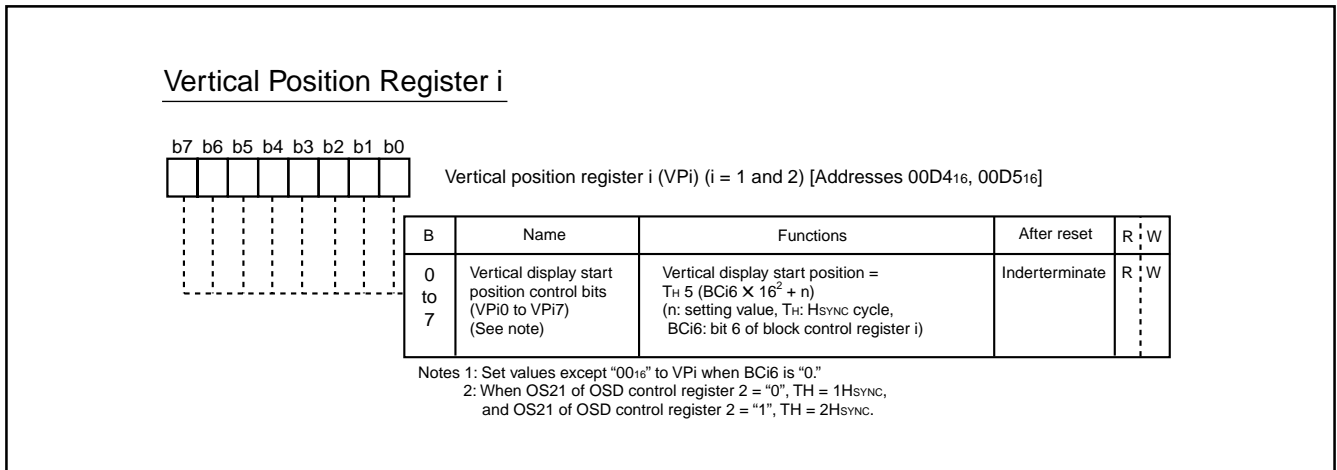

Fig. 8.11.7 Vertical Position Register i (i = 1 and 2)

M37151M6/M8/MA/MC/MF-XXXFP, M37151EFP

SINGLE-CHIP 8-BIT CMOS MICROCOMPUTER with CLOSED CAPTION DECODER and ON-SCREEN DISPLAY CONTROLLER

The horizontal display start position is common to all blocks, and can be set in 128 steps (where 1 step is 4Tosc, Tosc being the OSD oscillation cycle) as values "0016" to "FF16" in bits 0 to 6 of the horizontal position register (address 00D116). The horizontal position register is shown in Figure 8.11.8.

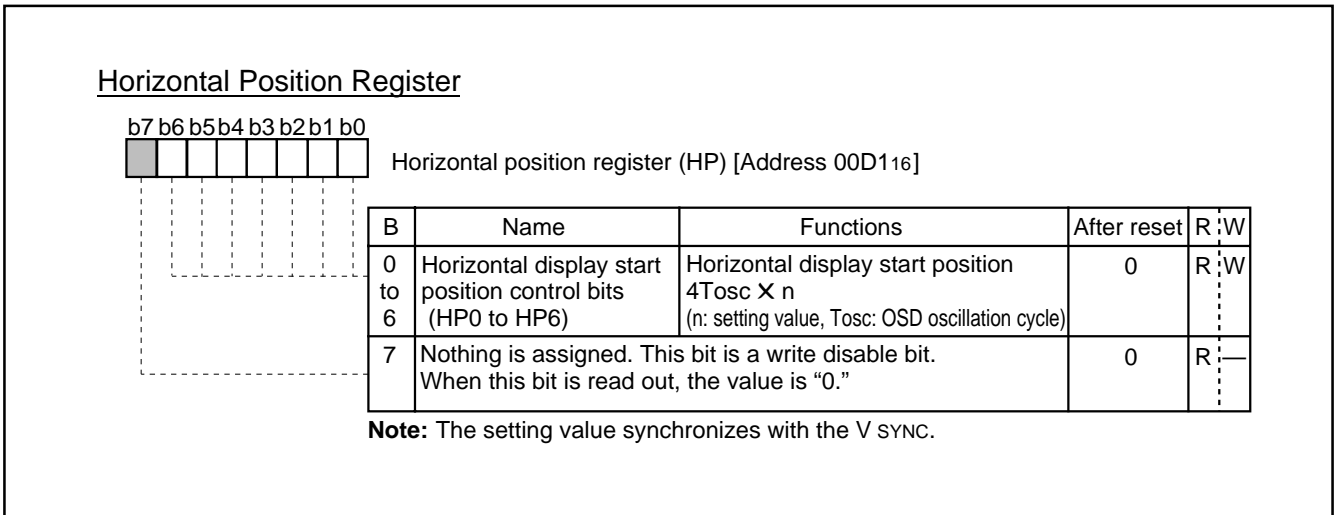

Fig. 8.11.8 Horizontal Position Register

- Notes 1 :** 1Tc (Tc : OSD clock cycle divided in pre-divide circuit) gap occurs between the horizontal display start position set by the horizontal position register and the most left dot of the 1st block. Accordingly, when 2 blocks have different pre-divide ratios, their horizontal display start position will not match.
- 2 :** The horizontal start position is based on the OSD clock source cycle selected for each block. Accordingly, when 2 blocks have different OSD clock source cycles, their horizontal display start position will not match.
- 3 :** When setting "0016" to the horizontal position register, it needs an approximately 62Tosc (= T_{def}) interval from a rising edge (when negative polarity is selected) of HSYNC signal to the horizontal display start position.

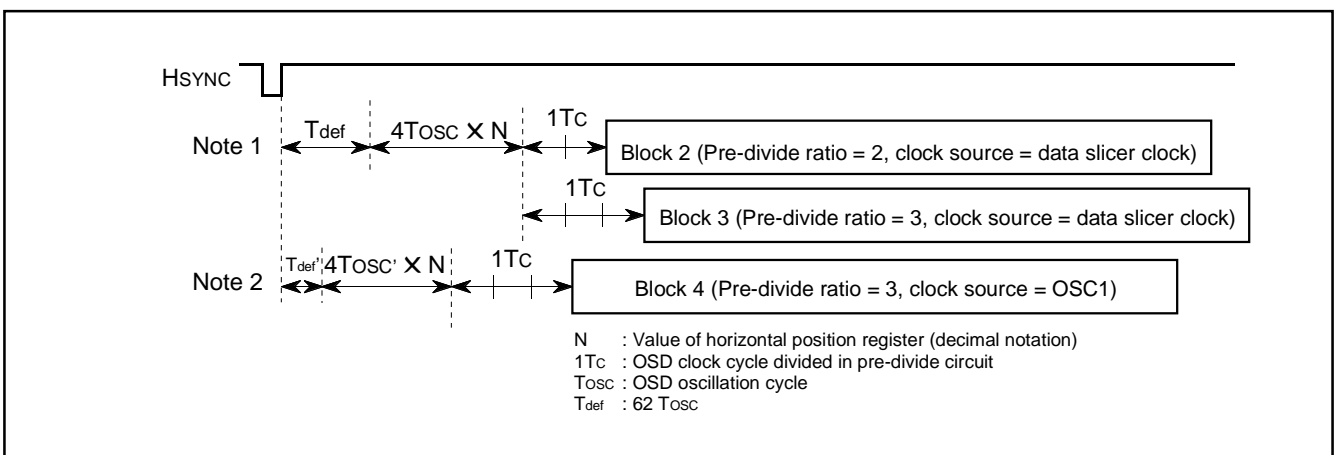

Fig. 8.11.9 Notes on Horizontal Display Start Position

M37151M6/M8/MA/MC/MF-XXXFP, M37151EFFP

SINGLE-CHIP 8-BIT CMOS MICROCOMPUTER with CLOSED CAPTION DECODER and ON-SCREEN DISPLAY CONTROLLER

8.11.2 Dot Size

The dot size can be selected in block units. The vertical dot size is determined by dividing HSYNC in the vertical dot size control circuit. The horizontal dot size is determined by dividing the following clock in the horizontal dot size control circuit : the clock gained by dividing the OSD clock source (data slicer clock, f (OSC) in the pre-divide circuit. The clock cycle divided in the pre-divide circuit is defined as $1T_c$.

The dot size of each block is specified by bits 2 to 4 of block control register i .

Refer to Figure 8.11.4 for the structure of the block control register.

The block diagram of the dot size control circuit is shown in Figure 8.11.10.

The pre-divide ratio is specified by bit 7 of the OSD control register (address 00D016) and bit 4 of block control register i (addresses 00D216 and 00D316) .

When bit 7 of the OSD control register (address 00D016) is set to "0," the double or triple pre-divide ratio can be chosen per block unit by bit 4 of block control register i . And then, when it is set to "1," the pre-divide ratio increases 1 time (both blocks 1 and 2). The pre-divided dot size can be specified per block unit by bits 2 and 3 of block control register i .

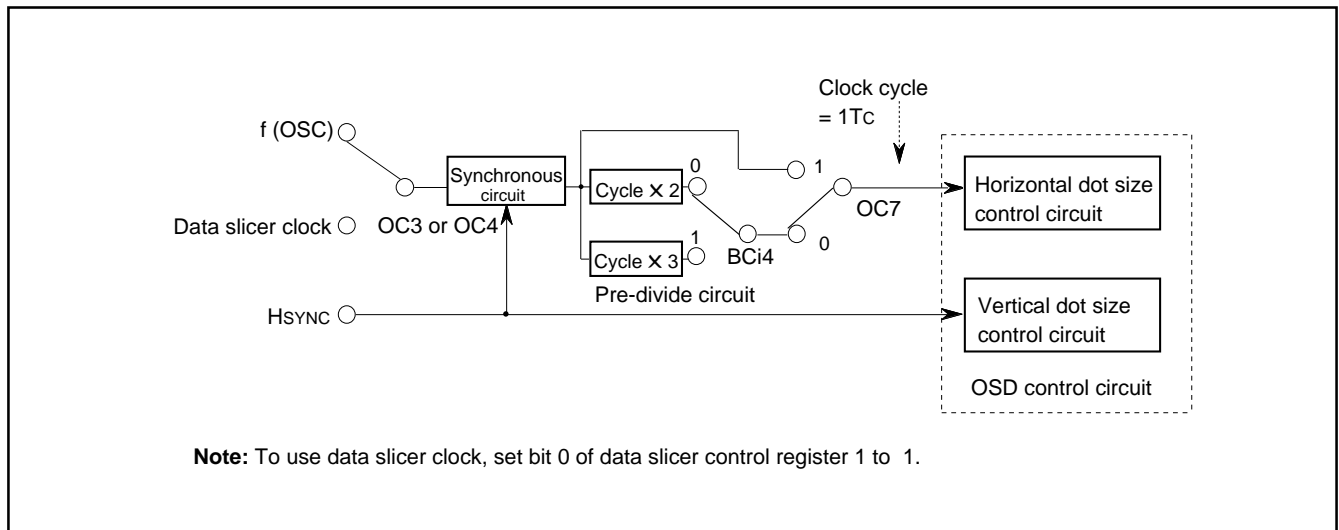

Fig. 8.11.10 Block Diagram of Dot Size Control Circuit

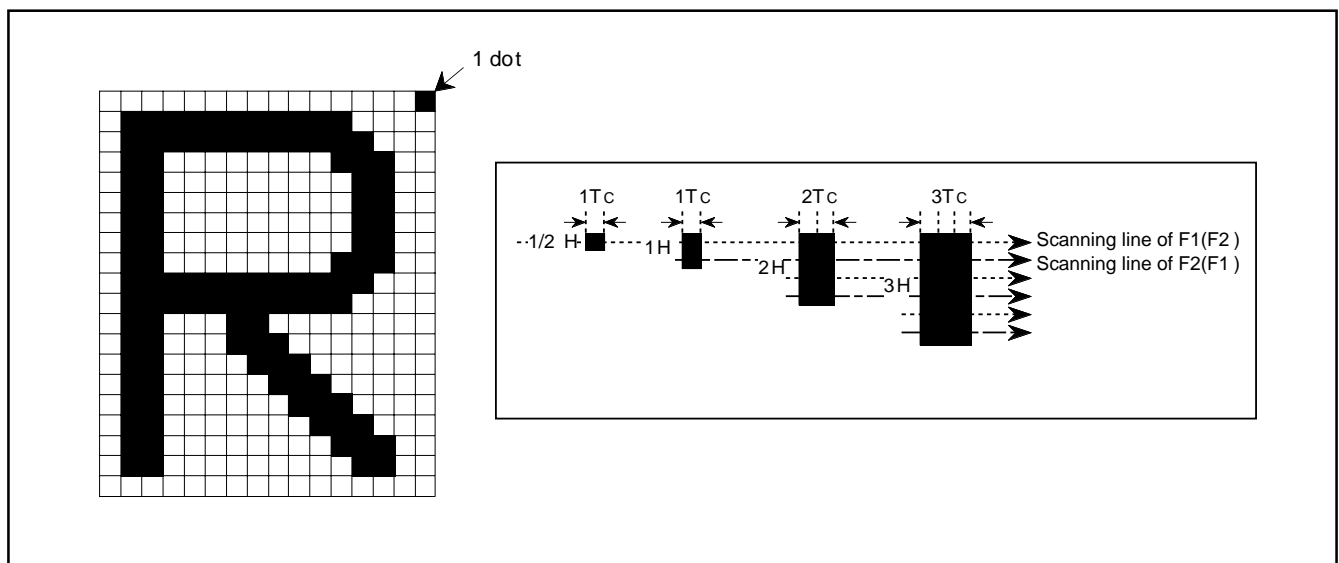

Fig. 8.11.11 Definition of Dot Sizes

M37151M6/M8/MA/MC/MF-XXXFP, M37151EFP

SINGLE-CHIP 8-BIT CMOS MICROCOMPUTER with CLOSED CAPTION DECODER and ON-SCREEN DISPLAY CONTROLLER

8.11.3 Clock for OSD

- The following 2 types of clocks can be selected for OSD display:
- Data slicer clock output from the data slicer (approximately 26 MHz)
 - OSD clock f (osc) generated based on the reference clock from pin XIN.

The OSD clock for each block can be selected by bits 3 and 4 of the clock source control register (addresses 00D0₁₆).

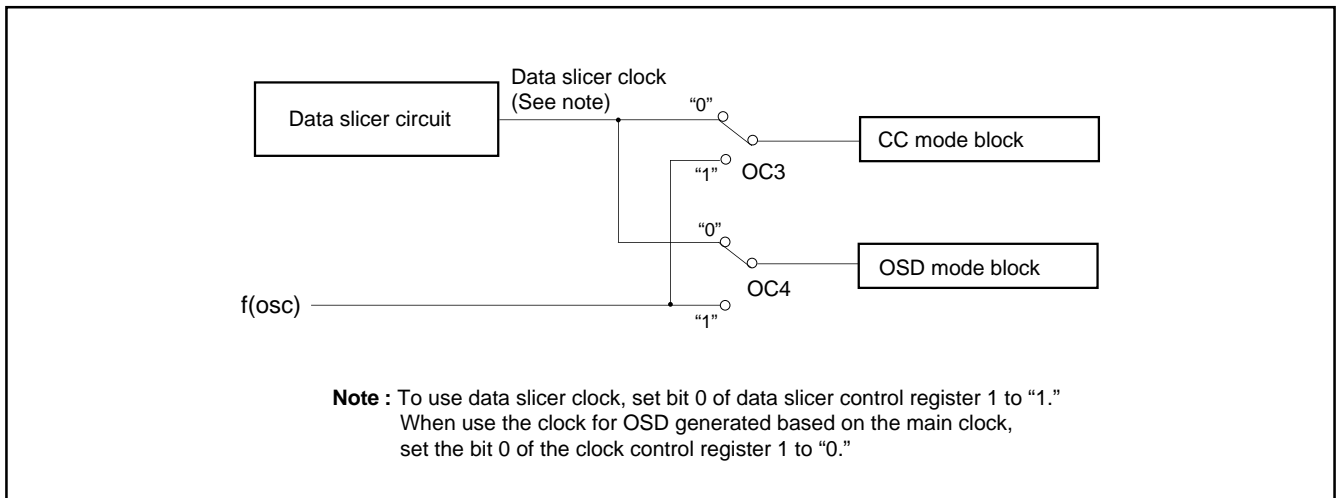

Fig. 8.11.12 Block Diagram of OSD Selection Circuit

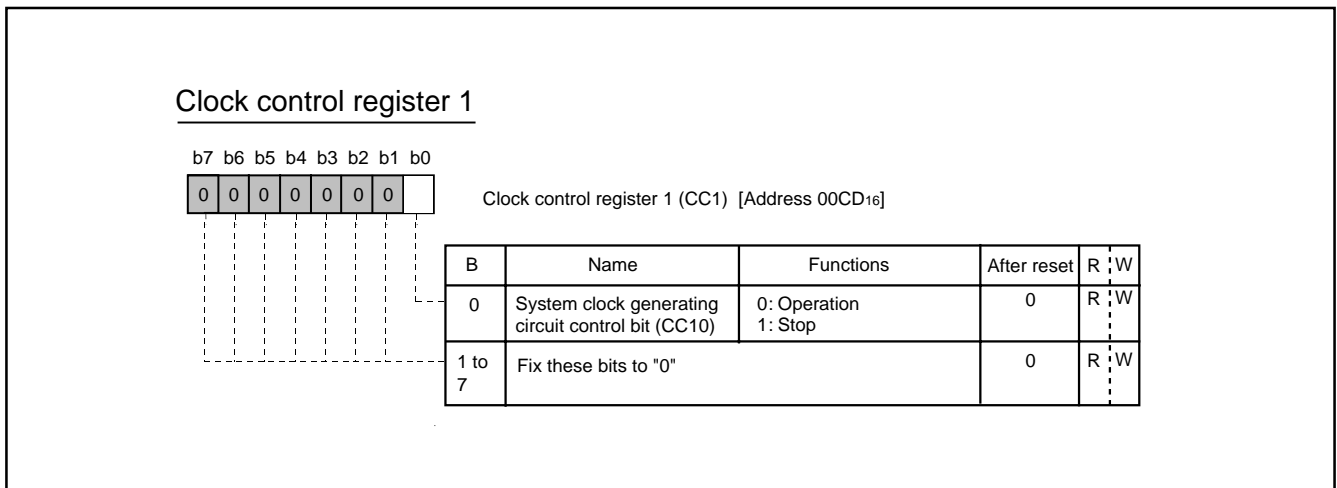

Fig. 8.11.13 Clock control register 1

M37151M6/M8/MA/MC/MF-XXXFP, M37151EFFP

SINGLE-CHIP 8-BIT CMOS MICROCOMPUTER with CLOSED CAPTION DECODER
and ON-SCREEN DISPLAY CONTROLLER

8.11.4 Field Determination Display

When displaying a block with vertical dot size of 1/2H, the differences in the synchronizing signal waveform of the interlacing system determine whether the field is odd or even. The dot lines 0 and 1 (refer to Figure 8.11.15), corresponding to each field, are displayed alternately.

In the following, the field determination standard for the case where both the horizontal sync signal and the vertical sync signal are negative-polarity inputs will be explained. A field determination is determined by detecting the time from a falling edge of the horizontal sync signal until a falling edge of the VSYNC control signal (refer to Figure 8.11.6) in the microcomputer and then comparing this time with the time of the previous field. When the time is longer than the previous time, it is regarded as an even field. When the time is shorter, it is regarded as an odd field.

The contents of this field can be read out by the field determination flag (bit 6 of the I/O polarity control register at address 00D8₁₆). A dot line is specified by bit 5 of the I/O polarity control register (refer to Figure 8.11.15).

However, the field determination flag read out from the CPU is fixed to "0" for even fields or "1" for odd fields, regardless of bit 5.

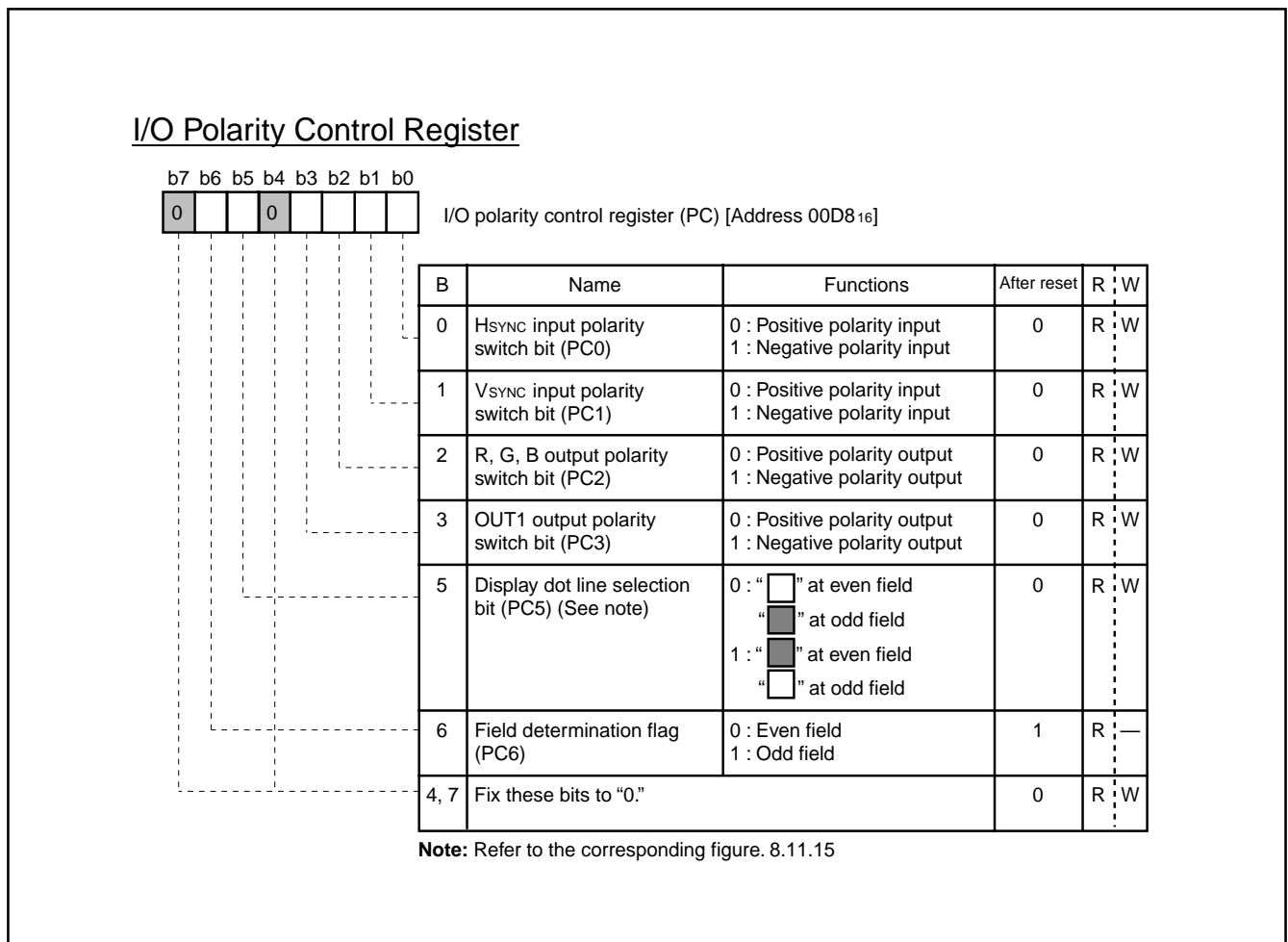

Fig. 8.11.14 I/O Polarity Control Register

M37151M6/M8/MA/MC/MF-XXXFP, M37151EFP

SINGLE-CHIP 8-BIT CMOS MICROCOMPUTER with CLOSED CAPTION DECODER and ON-SCREEN DISPLAY CONTROLLER

Both Hsync signal and Vsync signal are negative-polarity input

Hsync		Field	Field determination flag(Note)	Display dot line selection bit	Display dot line
Vsync and Vsync control signal in micro-computer		Odd	/	/	/
Upper : Vsync signal		Even	0 (T2 > T1)	0	Dot line 1 <input type="checkbox"/>
Lower : Vsync control signal in micro-computer		Odd	1 (T3 < T2)	1	Dot line 0 <input checked="" type="checkbox"/>
				1	Dot line 1 <input type="checkbox"/>

When using the field determination flag, be sure to set bit 0 of the PWM mode register 1 (address 0208 16) to "0."

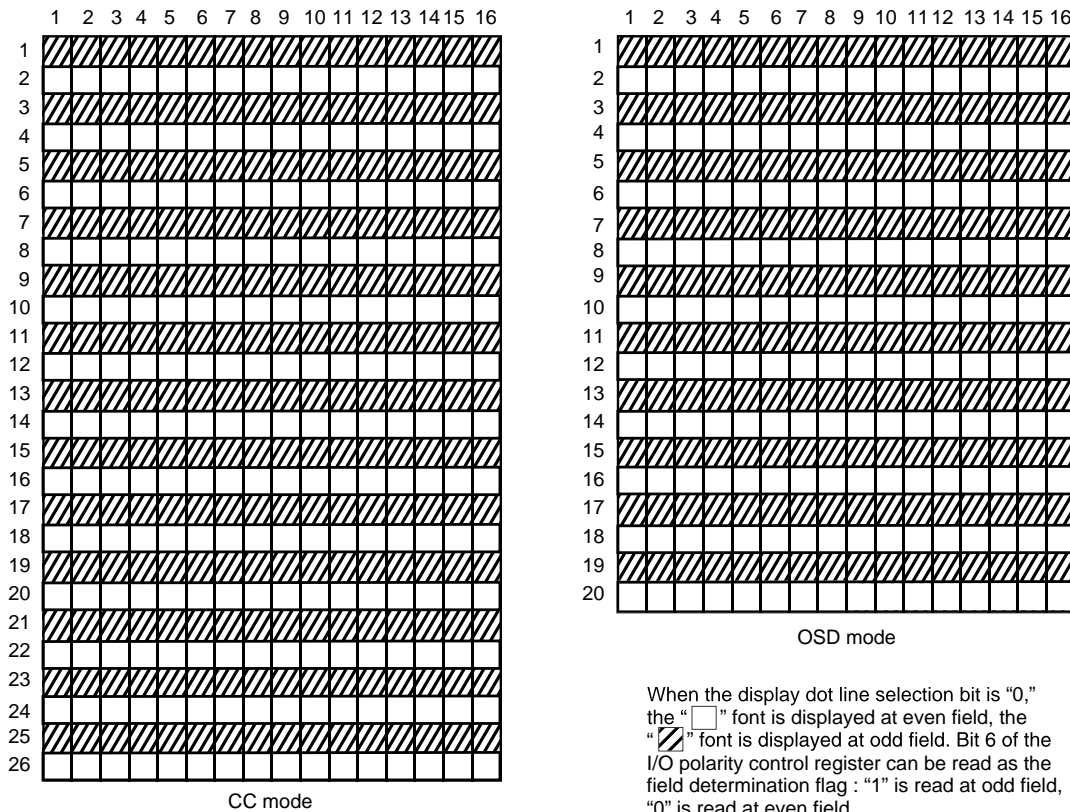

OSD ROM font configuration diagram

Note : The field determination flag changes at a rising edge of the V sync control signal (negative-polarity input) in the microcomputer.

Fig. 8.11.15 Relation between Field Determination Flag and Display Font

M37151M6/M8/MA/MC/MF-XXXFP, M37151EFFP

SINGLE-CHIP 8-BIT CMOS MICROCOMPUTER with CLOSED CAPTION DECODER
and ON-SCREEN DISPLAY CONTROLLER

8.11.5 Memory for OSD

There are 2 types of memory for OSD: OSD ROM used to store character dot data and OSD RAM used to specify the characters and colors to be displayed.

OSD ROM : addresses 11400₁₆ to 13BFF₁₆
OSD RAM : addresses 0800₁₆ to 087F₁₆

(1) OSD ROM

The dot pattern data for OSD characters is stored in the OSD ROM. To specify the kinds of character font, it is necessary to write the character code into the OSD RAM.

Data of the character font is specified as shown in Figure 8.11.16.

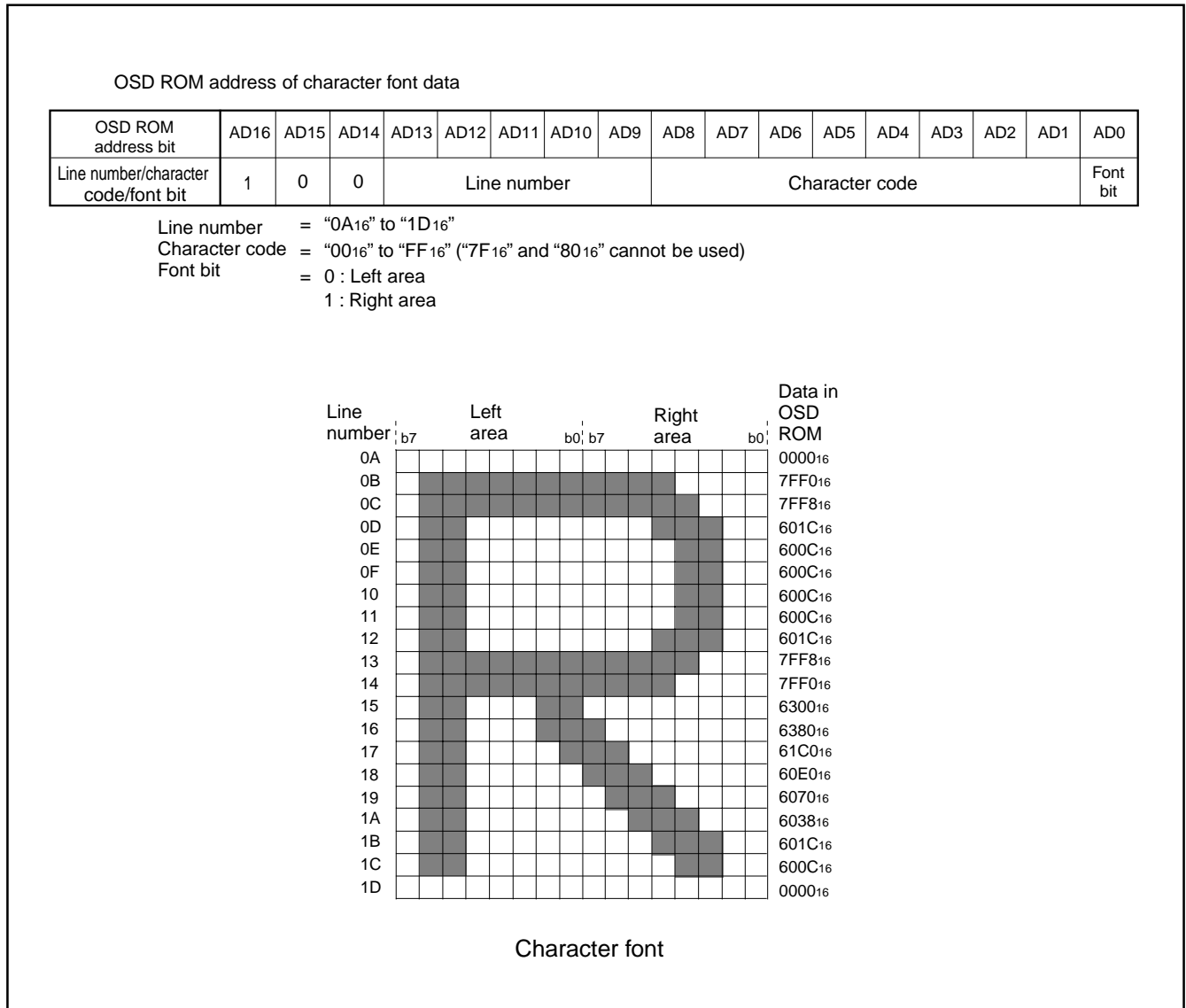

Fig. 8.11.16 Character Font Data Storing Address

M37151M6/M8/MA/MC/MF-XXXFP, M37151EFP

SINGLE-CHIP 8-BIT CMOS MICROCOMPUTER with CLOSED CAPTION DECODER
and ON-SCREEN DISPLAY CONTROLLER

Notes 1 : The 80-byte addresses corresponding to the character code "7F₁₆" and "80₁₆" in the OSD ROM are the test data storing area. Set data to the area as follows.

<Test data storing area>
addresses 11000₁₆ + (4 + 2n) X 100₁₆ + FE₁₆ to
11000₁₆ + (5 + 2n) X 100₁₆ + 01₁₆
(n = 0 to 19)

- (1)Mask version (M37151M6/M8/MA/MC/MF-XXXFP)
Set "FF₁₆" to the area (This sample has test data in this area but the actual product will have different data.) When using our font editor, the test data is written automatically.
- (2)EPROM version (M37151EFP)
Set the test data to the area. When using our font editor, the test data is written automatically.

2 : The character code "09₁₆" is used for "transparent space" when displaying Closed Caption. Therefore, set "00₁₆" to the 40-byte addresses corresponding to the character code "09₁₆."

<Transparent space font data storing area>
addresses 11000₁₆ + (4 + 2n) X 100₁₆ + 12₁₆ to
11000₁₆ + (4 + 2n) X 100₁₆ + 13₁₆
(n = 0 to 19)

addresses 11412₁₆ and 11413₁₆
addresses 11612₁₆ and 11613₁₆
⋮
addresses 13812₁₆ and 13813₁₆
addresses 13A12₁₆ and 13A13₁₆

■M37151EFP

<"7F₁₆"> address (test data)
114FE₁₆ (09₁₆), 114FF₁₆ (51₁₆)
116FE₁₆ (00₁₆), 116FF₁₆ (52₁₆)
118FE₁₆ (12₁₆), 118FF₁₆ (53₁₆)
11AFE₁₆ (00₁₆), 11AFF₁₆ (54₁₆)
11CFE₁₆ (24₁₆), 11CFF₁₆ (55₁₆)
11EFE₁₆ (00₁₆), 11EFF₁₆ (56₁₆)
120FE₁₆ (88₁₆), 120FF₁₆ (57₁₆)
122FE₁₆ (00₁₆), 122FF₁₆ (58₁₆)
124FE₁₆ (90₁₆), 124FF₁₆ (59₁₆)
126FE₁₆ (48₁₆), 126FF₁₆ (5A₁₆)
128FE₁₆ (24₁₆), 128FF₁₆ (5B₁₆)
12AFE₁₆ (00₁₆), 12AFF₁₆ (5C₁₆)
12CFE₁₆ (24₁₆), 12CFF₁₆ (5D₁₆)
12EFE₁₆ (48₁₆), 12EFF₁₆ (5E₁₆)
130FE₁₆ (00₁₆), 130FF₁₆ (5F₁₆)
132FE₁₆ (48₁₆), 132FF₁₆ (50₁₆)
134FE₁₆ (90₁₆), 134FF₁₆ (51₁₆)
136FE₁₆ (00₁₆), 136FF₁₆ (52₁₆)
138FE₁₆ (01₁₆), 138FF₁₆ (53₁₆)
13AFE₁₆ (80₁₆), 13AFF₁₆ (54₁₆)

<"80₁₆"> address (test data)
11500₁₆ (90₁₆), 11501₁₆ (A1₁₆)
11700₁₆ (00₁₆), 11701₁₆ (A2₁₆)
11900₁₆ (48₁₆), 11901₁₆ (A3₁₆)
11B00₁₆ (00₁₆), 11B01₁₆ (A4₁₆)
11D00₁₆ (24₁₆), 11D01₁₆ (A5₁₆)
11F00₁₆ (00₁₆), 11F01₁₆ (A6₁₆)
12100₁₆ (12₁₆), 12101₁₆ (A7₁₆)
12300₁₆ (00₁₆), 12301₁₆ (A8₁₆)
12500₁₆ (09₁₆), 12501₁₆ (A9₁₆)
12700₁₆ (00₁₆), 12701₁₆ (AA₁₆)
12900₁₆ (81₁₆), 12901₁₆ (AB₁₆)
12B00₁₆ (18₁₆), 12B01₁₆ (AC₁₆)
12D00₁₆ (00₁₆), 12D01₁₆ (AD₁₆)
12F00₁₆ (42₁₆), 12F01₁₆ (AE₁₆)
13100₁₆ (24₁₆), 13101₁₆ (AF₁₆)
13300₁₆ (00₁₆), 13301₁₆ (B0₁₆)
13500₁₆ (81₁₆), 13501₁₆ (B1₁₆)
13700₁₆ (0C₁₆), 13701₁₆ (B2₁₆)
13900₁₆ (06₁₆), 13901₁₆ (B3₁₆)
13B00₁₆ (00₁₆), 13B01₁₆ (B4₁₆)

M37151M6/M8/MA/MC/MF-XXXFP, M37151EFP

SINGLE-CHIP 8-BIT CMOS MICROCOMPUTER with CLOSED CAPTION DECODER
and ON-SCREEN DISPLAY CONTROLLER

(2) OSD RAM

The RAM for OSD is allocated at addresses 0800₁₆ to 087F₁₆, and is divided into a display character code specification part, color code 1 specification part, and color code 2 specification part for each block. Table 8.11.2 shows the contents of the OSD RAM.

For example, to display the first character position (the left edge) in block 1, write the character code in address 0800₁₆ and write the color code at 0820₁₆.

The structure of the OSD RAM is shown in Figure 8.11.17.

Table 8.11.2 Contents of OSD RAM

Block	Display Position (from left)	Character Code Specification	Color Code Specification
Block 1	1st character	0800 ₁₆	0820 ₁₆
	2nd character	0801 ₁₆	0821 ₁₆
	3rd character	0802 ₁₆	0822 ₁₆
	⋮	⋮	⋮
	30th character	081D ₁₆	083D ₁₆
	31st character	081E ₁₆	083E ₁₆
Block 2	32nd character	081F ₁₆	083F ₁₆
	1st character	0840 ₁₆	0860 ₁₆
	2nd character	0841 ₁₆	0861 ₁₆
	3rd character	0842 ₁₆	0862 ₁₆
	⋮	⋮	⋮
	30th character	085D ₁₆	087D ₁₆
	31st character	085E ₁₆	087E ₁₆
	32nd character	085F ₁₆	087F ₁₆

M37151M6/M8/MA/MC/MF-XXXFP, M37151EFP

SINGLE-CHIP 8-BIT CMOS MICROCOMPUTER with CLOSED CAPTION DECODER
and ON-SCREEN DISPLAY CONTROLLER

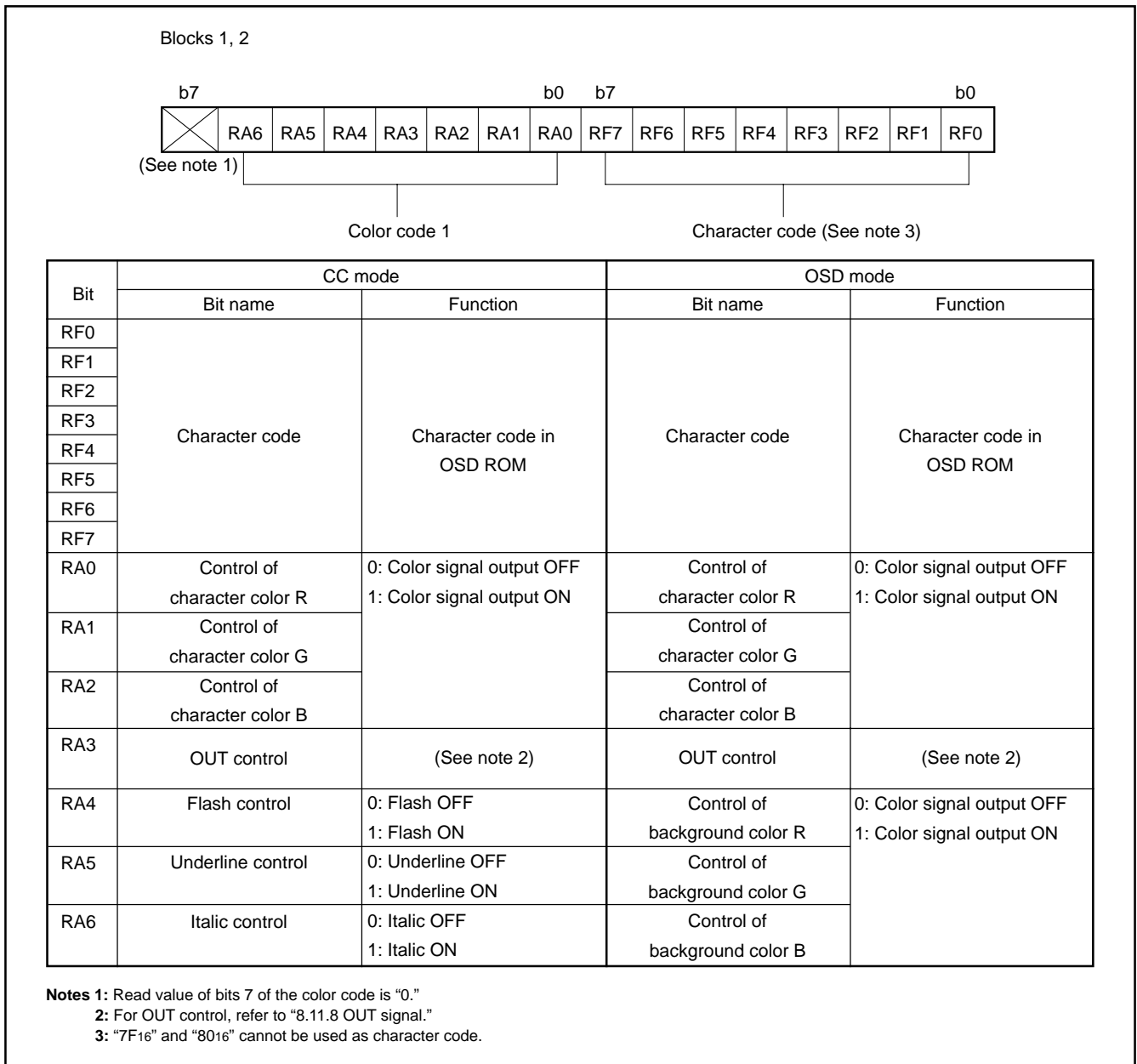

Fig. 8.11.17 Bit structure of OSD RAM

M37151M6/M8/MA/MC/MF-XXXFP, M37151EFP

SINGLE-CHIP 8-BIT CMOS MICROCOMPUTER with CLOSED CAPTION DECODER
and ON-SCREEN DISPLAY CONTROLLER

8.11.6 Character color

The color for each character is displayed by the color code.
The 7 kinds of color are specified by bits 0 (R), 1 (G), and 2 (B) of the color code.

8.11.7 Character background color

The character background color can be displayed in the character display area only in the OSD mode. The character background color for each character is specified by the color code.
The 7 kinds of color are specified by bits 0 (R), 1 (G), and 2 (B) of the color code.

Note : The character background color is displayed in the following parts:
(character display area)–(character font)–(border).
Accordingly, the character background color does not mix with these color signals.

M37151M6/M8/MA/MC/MF-XXXFP, M37151EFP

SINGLE-CHIP 8-BIT CMOS MICROCOMPUTER with CLOSED CAPTION DECODER and ON-SCREEN DISPLAY CONTROLLER

8.11.8 OUT signal

The OUT signal is used to control the luminance of the video signal. The output waveform of the OUT signal is controlled by RA3 of the OSD RAM. The setting values for controlling OUT and the corresponding output waveform are shown in Figure 8.11.18.

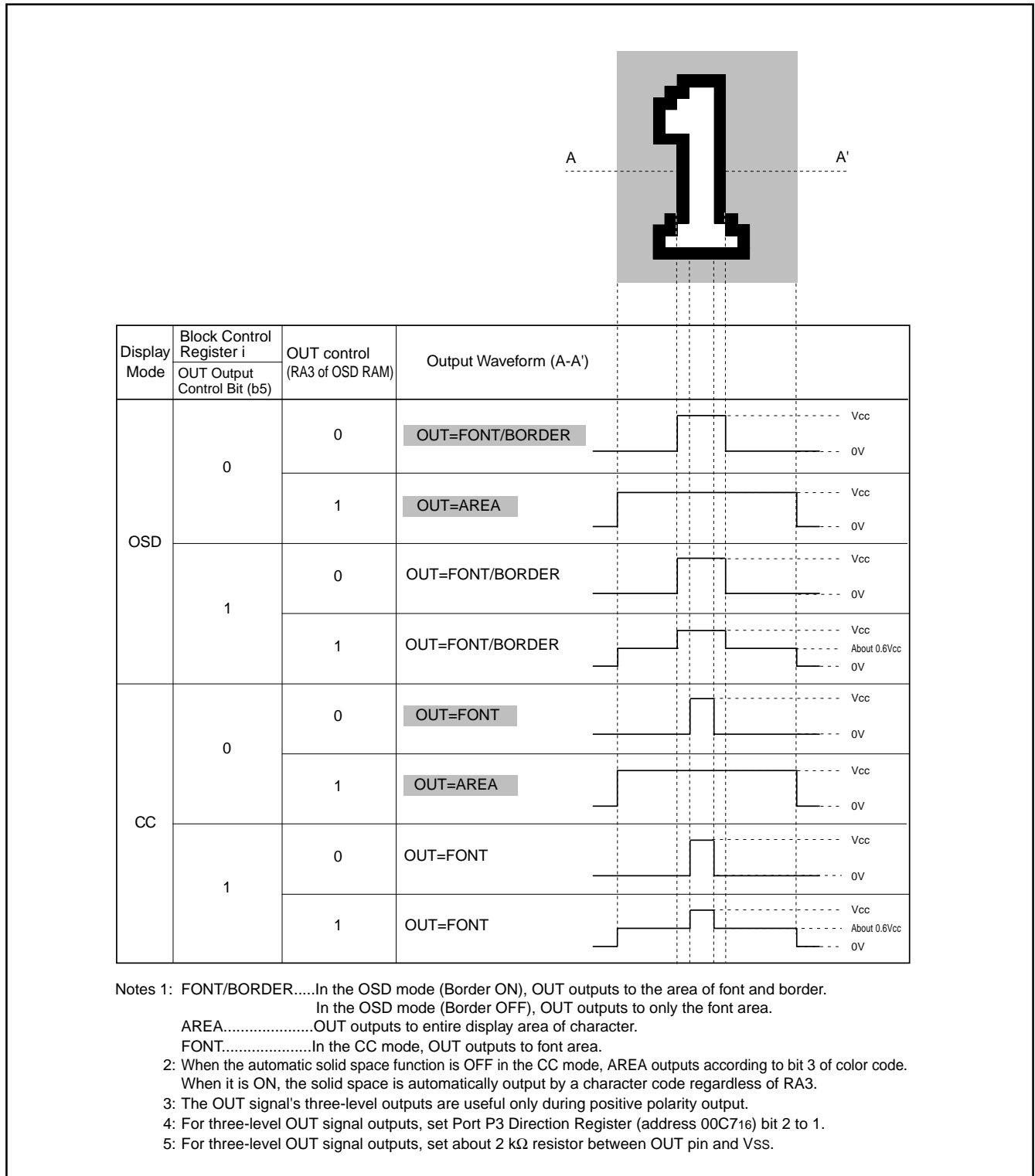

Fig. 8.11.18 Setting Value for Controlling OUT and Corresponding Output Waveform

M37151M6/M8/MA/MC/MF-XXXFP, M37151EFFP

SINGLE-CHIP 8-BIT CMOS MICROCOMPUTER with CLOSED CAPTION DECODER
and ON-SCREEN DISPLAY CONTROLLER

8.11.9 Attribute

The attributes (border, flash, underline, italic) are controlled according to the character font. The attributes to be controlled are different depending on each mode.

CC mode Flash, underline, italic (per character unit)

OSD mode Border (per character unit)

(1) Underline

The underline is output at the 23th and 24th dots in the vertical direction only in the CC mode. The underline is controlled by RA5 of the OSD RAM. The color of the underline is the same color as that of the character font.

(2) Flash

The character font and the underline are flashed only in the CC mode. The flash is controlled by RA4 of OSD RAM. In the character font part, the character output part is flashed, but the character background part is not flashed. The flash cycle is based on the VSYNC count.

- VSYNC cycle X 48 ≈ 800 ms (at display ON)
- VSYNC cycle X 16 ≈ 267 ms (at display OFF)

(3) Italic

The italic is made by slanting the font stored in the OSD ROM to the right only in the CC mode. The italic is controlled by RA6 of OSD RAM.

Display examples of the italic and underline are shown in Figure 8.11.19, using "R."

- Notes**
- 1: When setting both the italic and the flash, the italic character flashes.
 - 2: The boundary of character color is displayed in italic. However, the boundary of character background color is not affected by the italic (refer to Figure 8.11.20).
 - 3: The adjacent character (one side or both sides) to an italic character is displayed in italic even when the character is not specified to be displayed in italic (refer to Figure 8.11.20).
 - 4: Italics display cannot be used at pre-divided ratio 1 setting .

M37151M6/M8/MA/MC/MF-XXXFP, M37151EFP

SINGLE-CHIP 8-BIT CMOS MICROCOMPUTER with CLOSED CAPTION DECODER
and ON-SCREEN DISPLAY CONTROLLER

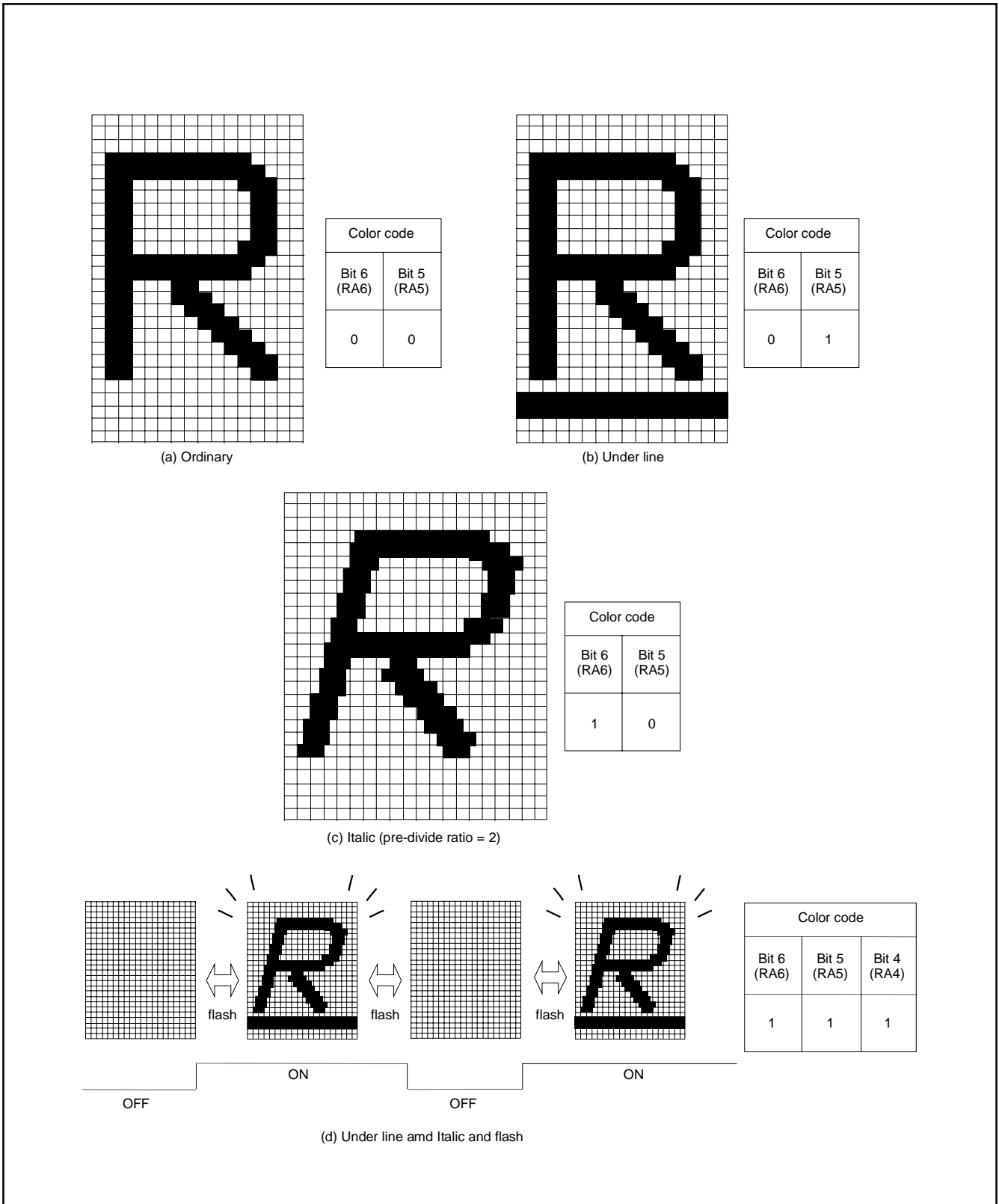

Fig. 8.11.19 Example of Attribute Display (in CC Mode)

M37151M6/M8/MA/MC/MF-XXXFP, M37151EFP

SINGLE-CHIP 8-BIT CMOS MICROCOMPUTER with CLOSED CAPTION DECODER
and ON-SCREEN DISPLAY CONTROLLER

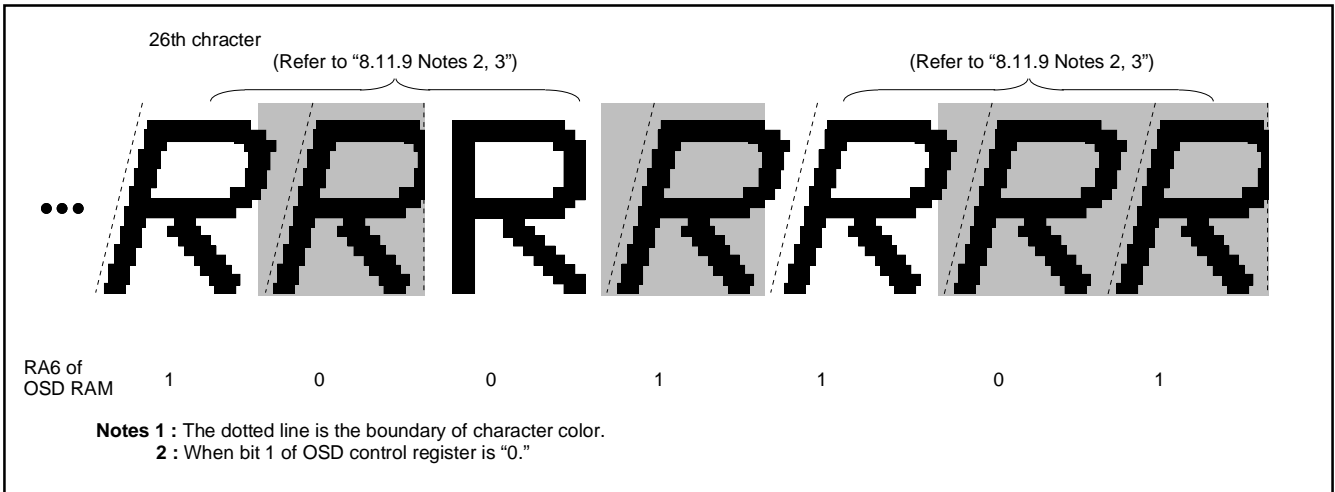

Fig. 8.11.20 Example of Italic Display

M37151M6/M8/MA/MC/MF-XXXFP, M37151EFP

SINGLE-CHIP 8-BIT CMOS MICROCOMPUTER with CLOSED CAPTION DECODER and ON-SCREEN DISPLAY CONTROLLER

(4) Border

The border is output around the character font (all bordered) in the OSD mode only. The border ON/OFF is controlled by bit 0 and 1 of block control register i (refer to Figure 8.11.4).

The OUT signal is used for border output.

The horizontal size (x) of the border is 1Tc (OSD clock cycle divided in pre-divide circuit) regardless of the character font dot size. The vertical size (y) differs depending on the screen scan mode and the vertical dot size of the character font.

- Notes 1 :** The border dot area is the shaded area as shown in Figure 8.11.21.
- 2 :** When the border dot overlaps on the next character font, the character font has priority (refer to Figure 8.11.23 A).
When the border dot overlaps the next character back ground, the border has priority (refer to Figure 8.11.23 B).
- 3 :** The border in vertical out of the character area is not displayed (refer to Figure 8.11.23).

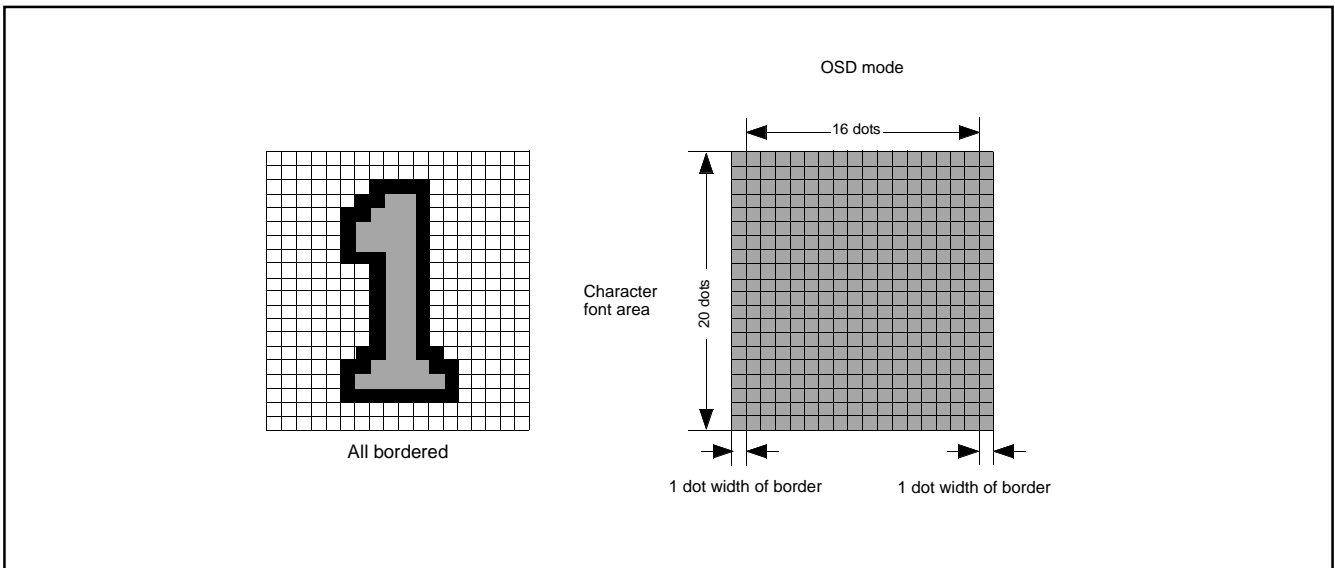

Fig. 8.11.21 Example of Border Display

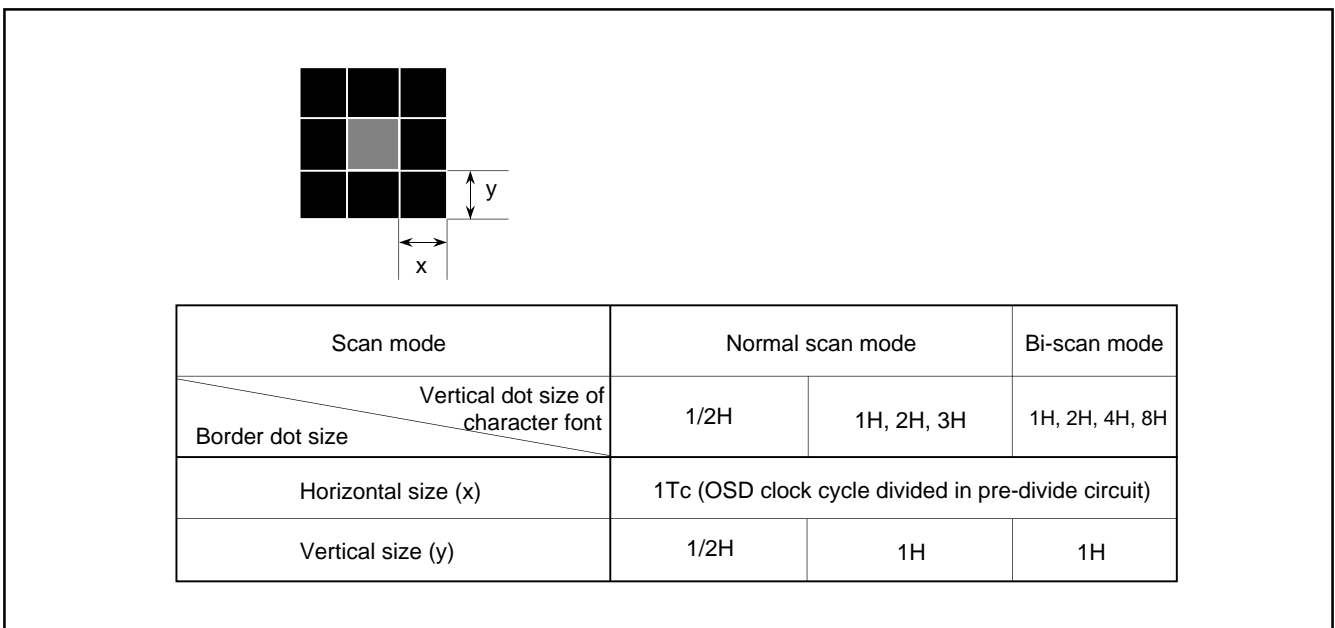

Fig. 8.11.22 Horizontal and Vertical Size of Border

M37151M6/M8/MA/MC/MF-XXXFP, M37151EFFP

SINGLE-CHIP 8-BIT CMOS MICROCOMPUTER with CLOSED CAPTION DECODER
and ON-SCREEN DISPLAY CONTROLLER

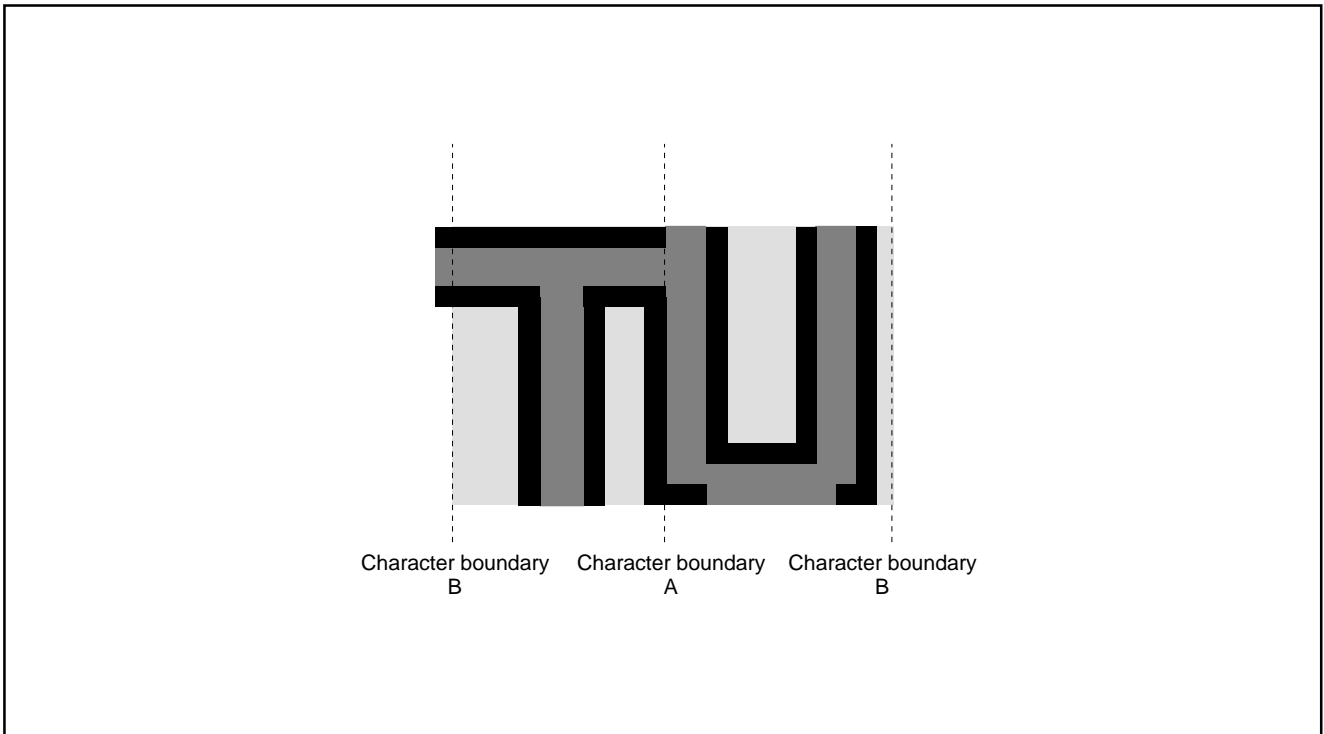

Fig. 8.11.23 Border Priority

M37151M6/M8/MA/MC/MF-XXXFP, M37151EFP

SINGLE-CHIP 8-BIT CMOS MICROCOMPUTER with CLOSED CAPTION DECODER and ON-SCREEN DISPLAY CONTROLLER

8.11.10 Multiline Display

This microcomputer can display 2 lines on the CRT screen by displaying 2 blocks at different vertical positions. In addition, it can display up to 16 lines by using OSD interrupts.

An OSD interrupt request occurs at the point at which that display of each block has been completed. In other words, when a scanning line reaches the point of the display position (specified by the vertical position registers) of a certain block, the character display of that block starts, and an interrupt occurs at the point at which the scanning line exceeds the block.

- Notes 1:** An OSD interrupt does not occur at the end of display when the block is not displayed. In other words, if a block is set to display off by the display control bit of the block control register (addresses 00D216, 00D316), an OSD interrupt request does not occur (refer to Figure 8.11.24 (A)).
- 2:** When another block display appears while one block is displayed, an OSD interrupt request occurs only once at the end of the second block display (refer to Figure 8.11.24 (B)).
- 3:** On the screen setting window, an OSD interrupt occurs even at the end of the CC mode block (display off) out of window (refer to Figure 8.11.24 (C)).

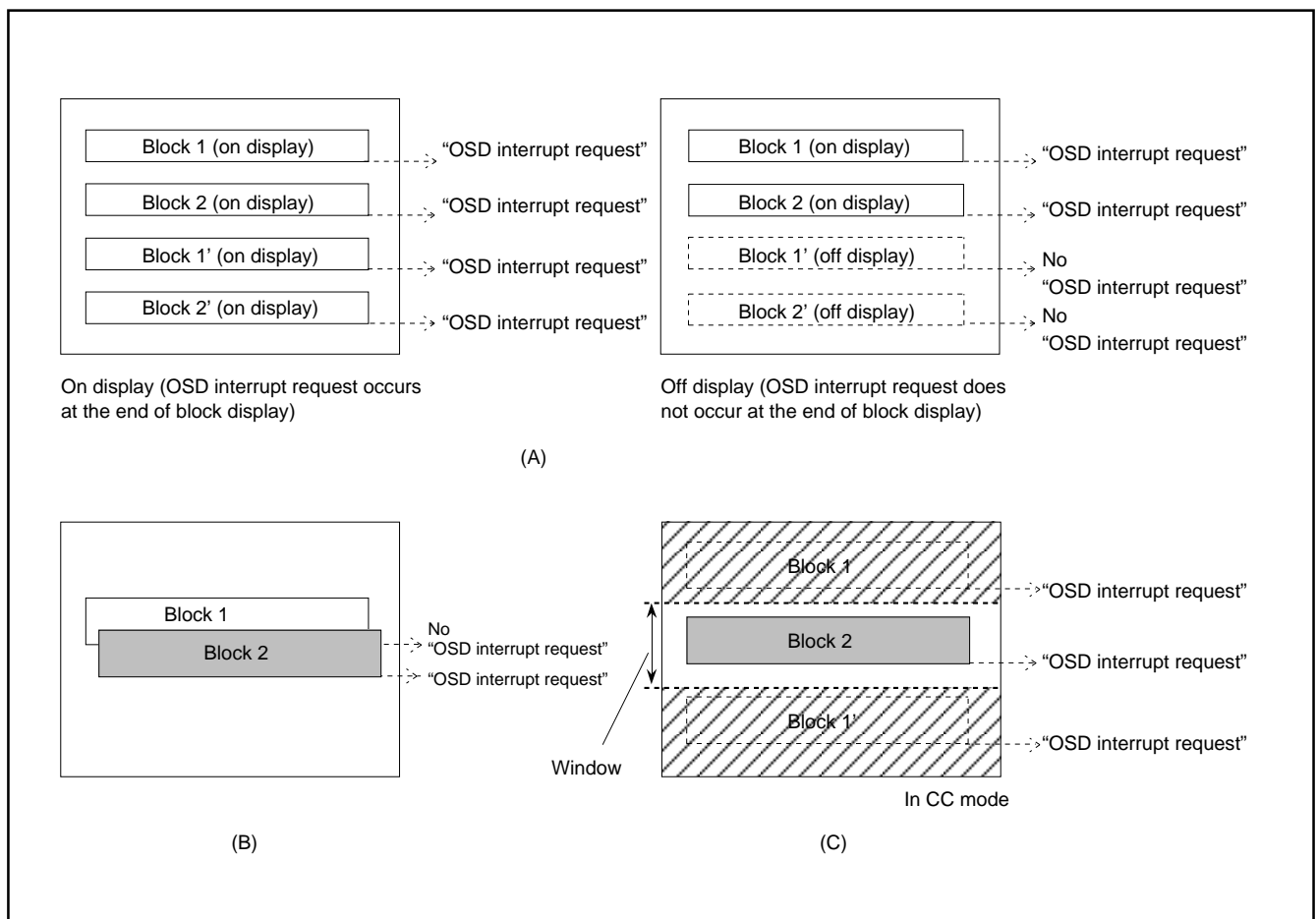

Fig. 8.11.24 Note on Occurrence of OSD Interrupt

M37151M6/M8/MA/MC/MF-XXXFP, M37151EFFP

SINGLE-CHIP 8-BIT CMOS MICROCOMPUTER with CLOSED CAPTION DECODER and ON-SCREEN DISPLAY CONTROLLER

8.11.11 Automatic Solid Space Function

This function automatically generates the solid space (OUT blank output) of the character area in the CC mode.

The solid space is output in the following areas:

- Any character area except character code "09₁₆"
- Character area on the left and right sides of the above character

This function is turned on and off by bit 1 of the OSD control register (refer to Figure 8.11.3).

Notes : The character code "09₁₆" is used for "transparent space" when displaying Closed Caption. Therefore, set "00₁₆" to the 40-byte addresses corresponding to the character code "09₁₆."

<Transparent space font data storing area>
 addresses 11000₁₆ + (4 + 2n) × 100₁₆ + 12₁₆ to
 11000₁₆ + (4 + 2n) × 100₁₆ + 13₁₆
 (n = 0 to 19)

[addresses 11412₁₆ and 11413₁₆
 addresses 11612₁₆ and 11613₁₆
 ⋮
 addresses 13812₁₆ and 13813₁₆
 addresses 13A12₁₆ and 13A13₁₆]

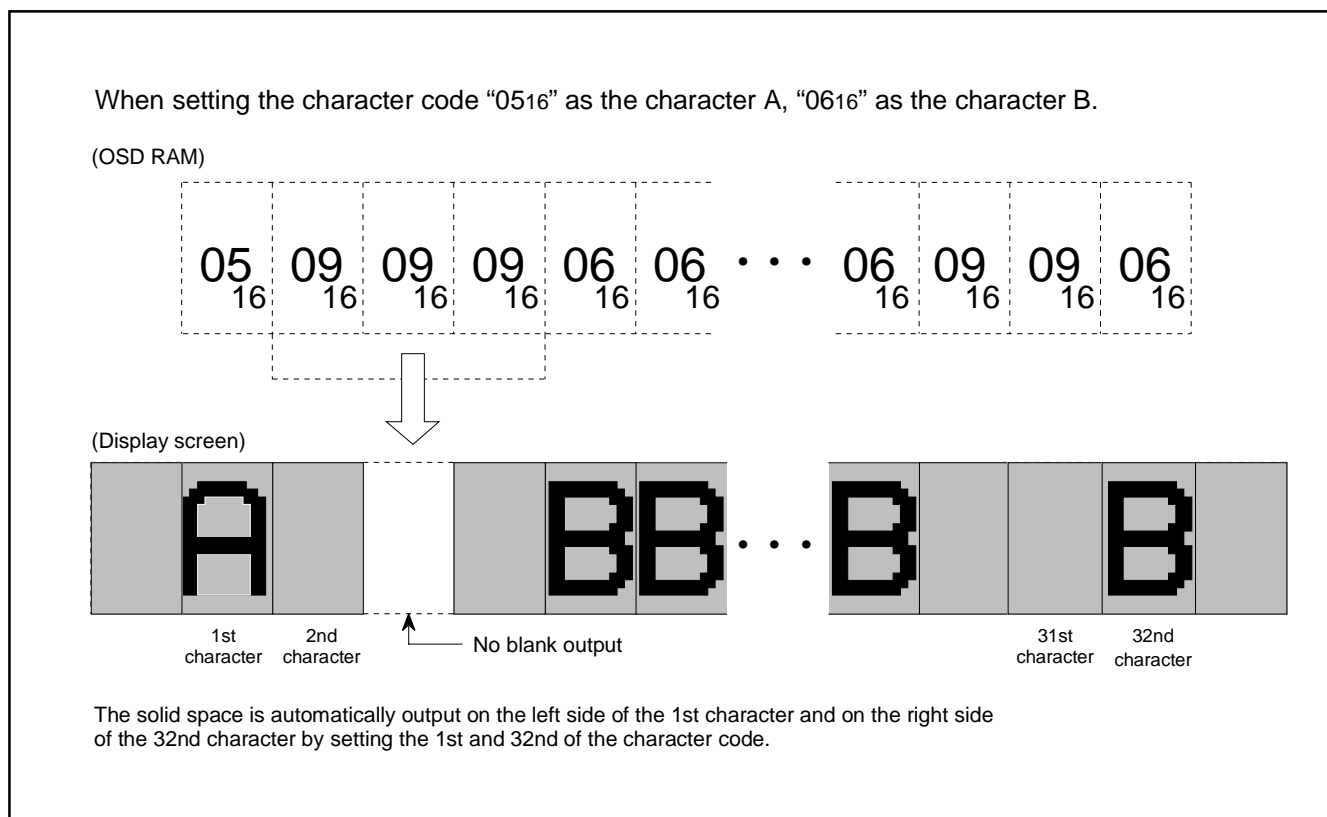

Fig. 8.11.25 Display Screen Example of Automatic Solid Space

M37151M6/M8/MA/MC/MF-XXXFP, M37151EFP

SINGLE-CHIP 8-BIT CMOS MICROCOMPUTER with CLOSED CAPTION DECODER and ON-SCREEN DISPLAY CONTROLLER

8.11.12 Window Function

This function sets the top and bottom boundaries for display limits on a screen. The window function is valid only in the CC mode. The top boundary is set by the window register 1 and bit 7 of block control register 1. The bottom boundary is set by window register 1 and bit 7 of block control register 2. This function is turned on and off by bit 2 of the OSD control register (refer to Figure 8.11.3).

Window registers 1 and 2 are shown in Figures 8.11.27 and 8.11.28.

The setting value per one step of the top and bottom window borders can be switched to either 1TH or 2TH by setting "0" or "1" to bit 1 of OSD control register 2 (address 02DB16).

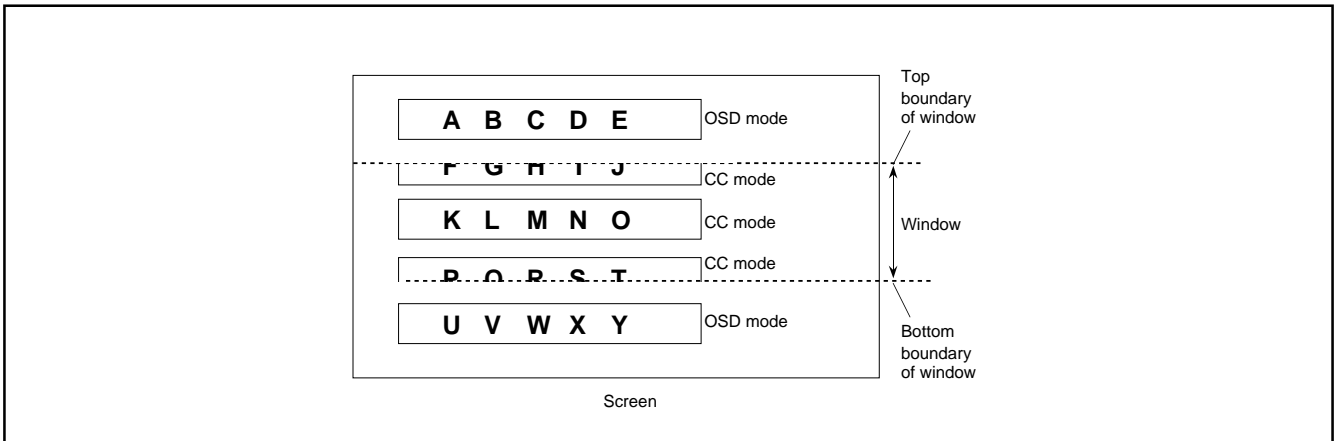

Fig. 8.11.26 Example of Window Function

M37151M6/M8/MA/MC/MF-XXXFP, M37151EFFP

SINGLE-CHIP 8-BIT CMOS MICROCOMPUTER with CLOSED CAPTION DECODER
and ON-SCREEN DISPLAY CONTROLLER

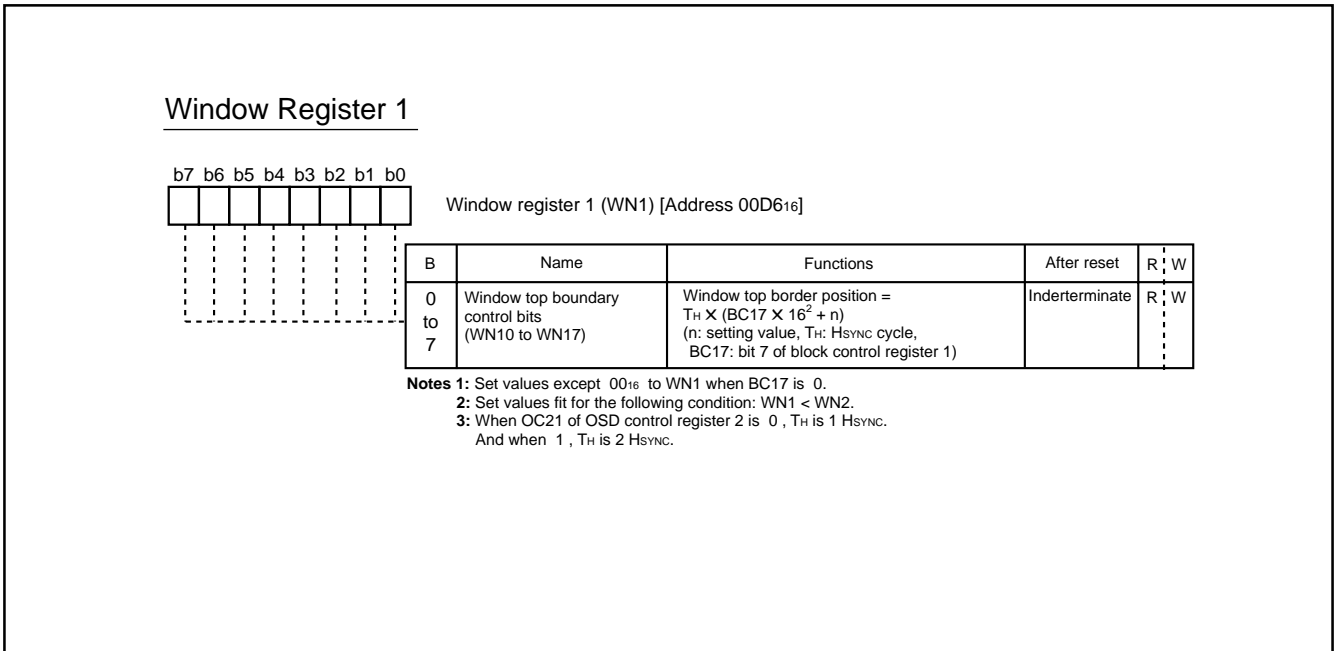

Fig. 8.11.27 Window Register 1

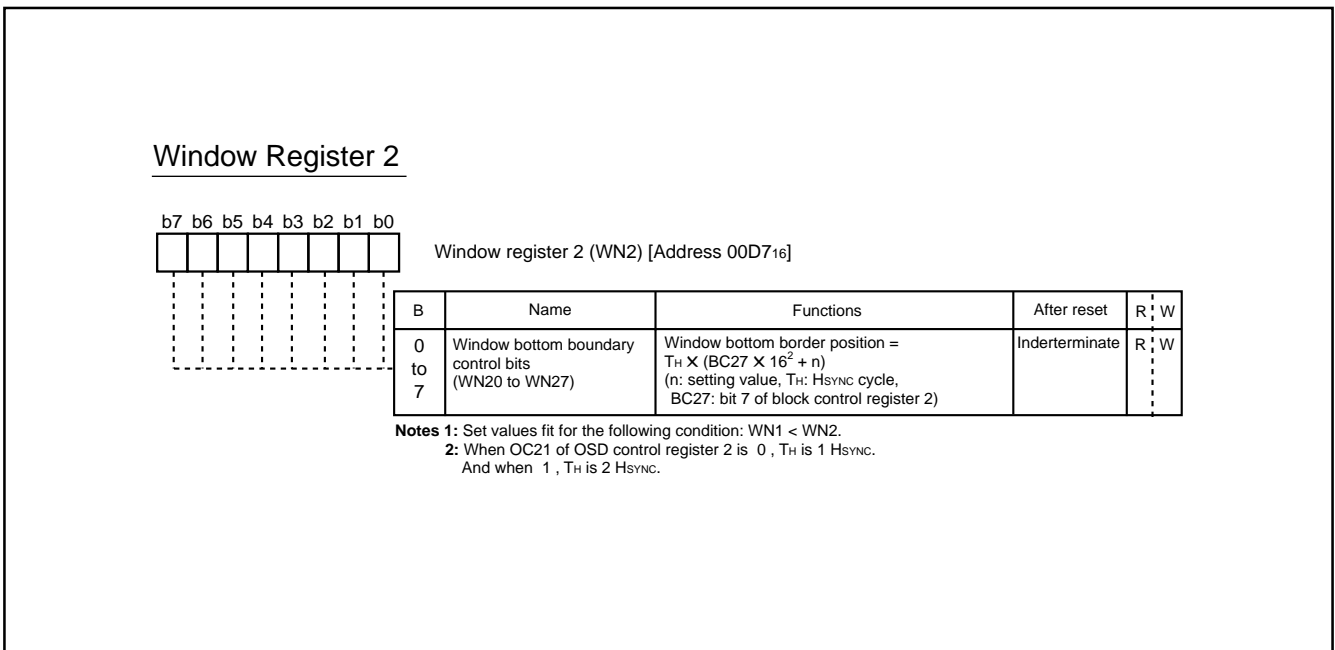

Fig. 8.11.28 Window Register 2

M37151M6/M8/MA/MC/MF-XXXFP, M37151EFP

SINGLE-CHIP 8-BIT CMOS MICROCOMPUTER with CLOSED CAPTION DECODER
and ON-SCREEN DISPLAY CONTROLLER

8.11.13 OSD Output Pin Control

The OSD output pins R, G, B and OUT can also function as ports P52–P55. Set the corresponding bit of the OSD port control register (address 00CB16) to “0” to specify these pins as OSD output pins, or to “1” to specify as the general-purpose port P5.

The input polarity of the HSYNC and VSYNC, and the output polarity of signals R, G, B, OUT can be specified with the I/O polarity control register (address 00D8). Set bits to “0” to specify positive polarity; “1” to specify negative polarity (refer to Figure 8.11.14).

The structure of the OSD port control register is shown in Figure 8.11.29.

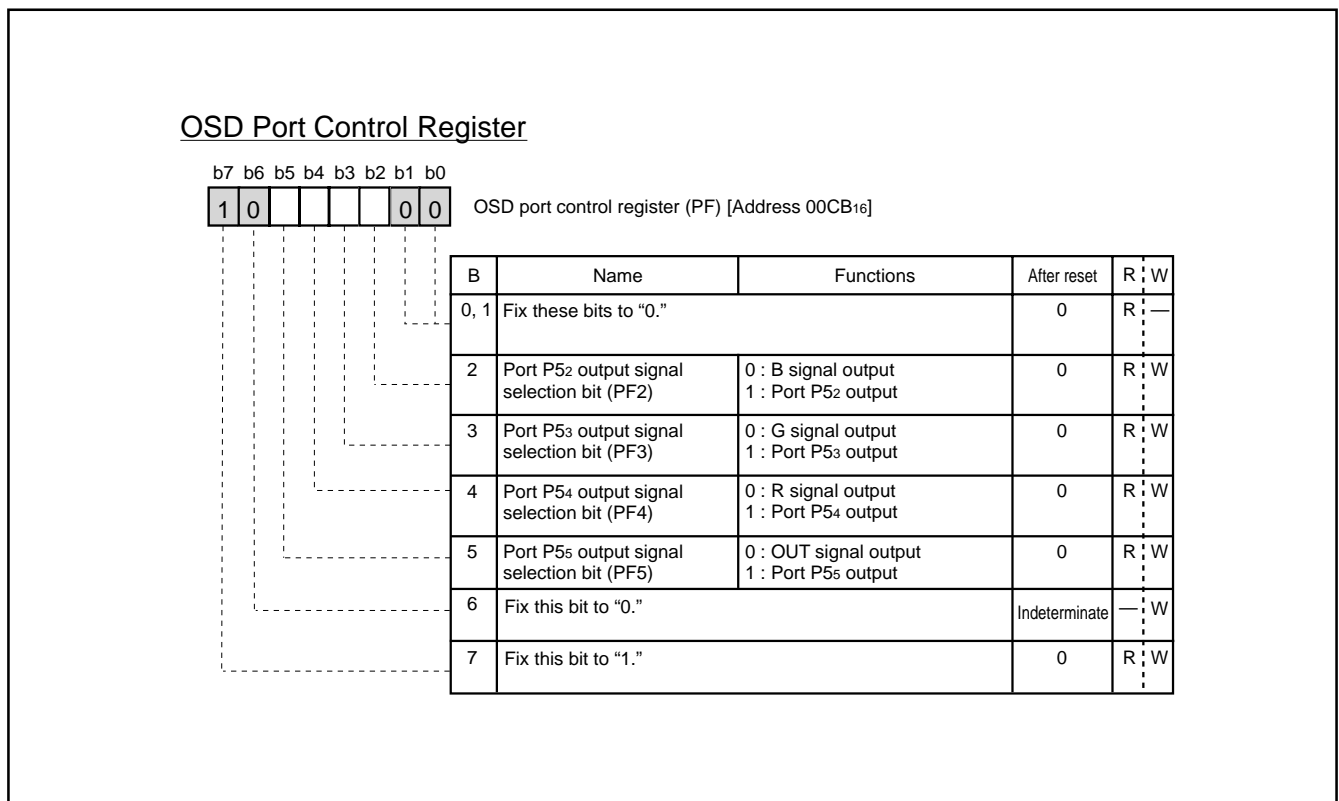

Fig. 8.11.29 OSD Port Control Register

M37151M6/M8/MA/MC/MF-XXXFP, M37151EFFP

SINGLE-CHIP 8-BIT CMOS MICROCOMPUTER with CLOSED CAPTION DECODER
and ON-SCREEN DISPLAY CONTROLLER

8.11.14 Raster Coloring Function

An entire screen (raster) can be colored by setting bits 4 to 0 of the raster color register. Since each of the R, G, B, OUT pins can be switched to raster coloring output, 8 raster colors can be obtained.

When the character color/character background color overlaps with the raster color, the color (R, G, B, OUT), specified for the character color/character background color, takes priority over the raster color. This ensures that character color/character background color is not mixed with the raster color.

The raster color register is shown in Figure 8.11.30, an example of raster coloring is shown in Figure 8.11.31.

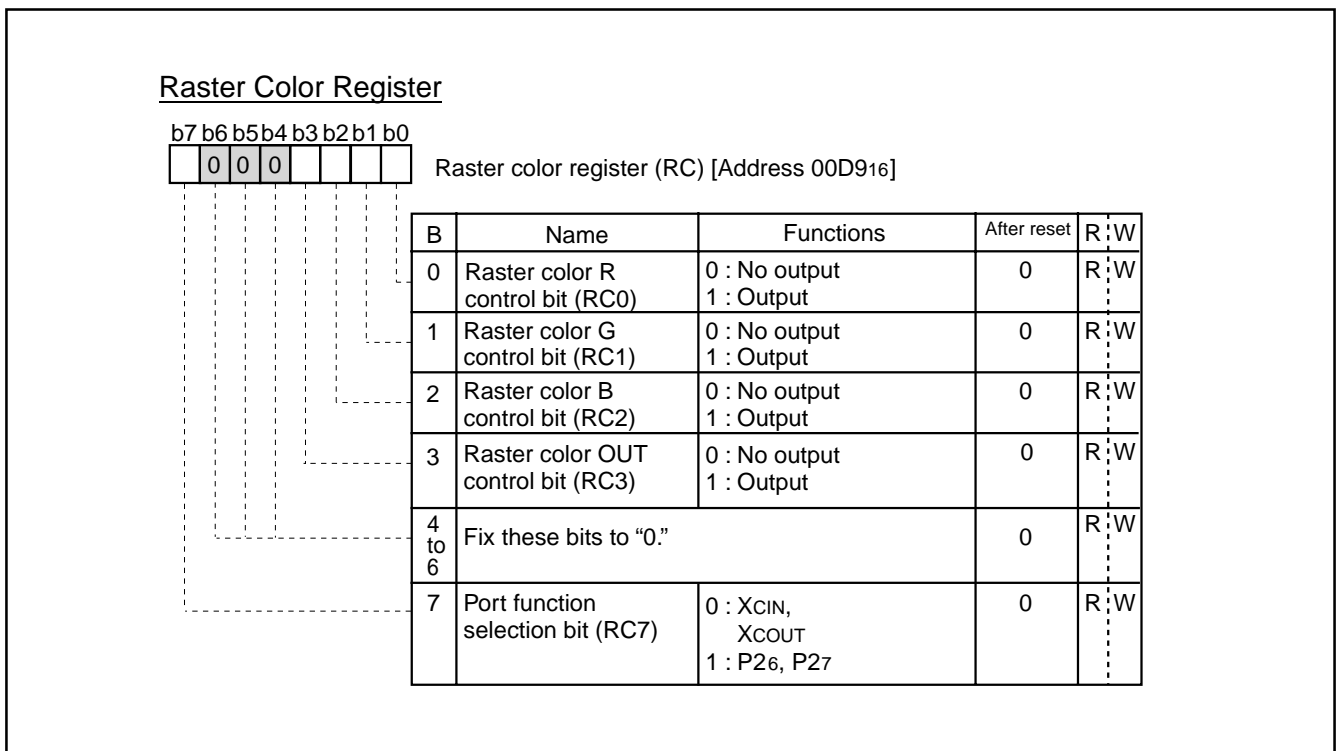

Fig. 8.11.30 Raster Color Register

M37151M6/M8/MA/MC/MF-XXXFP, M37151EFP

SINGLE-CHIP 8-BIT CMOS MICROCOMPUTER with CLOSED CAPTION DECODER
and ON-SCREEN DISPLAY CONTROLLER

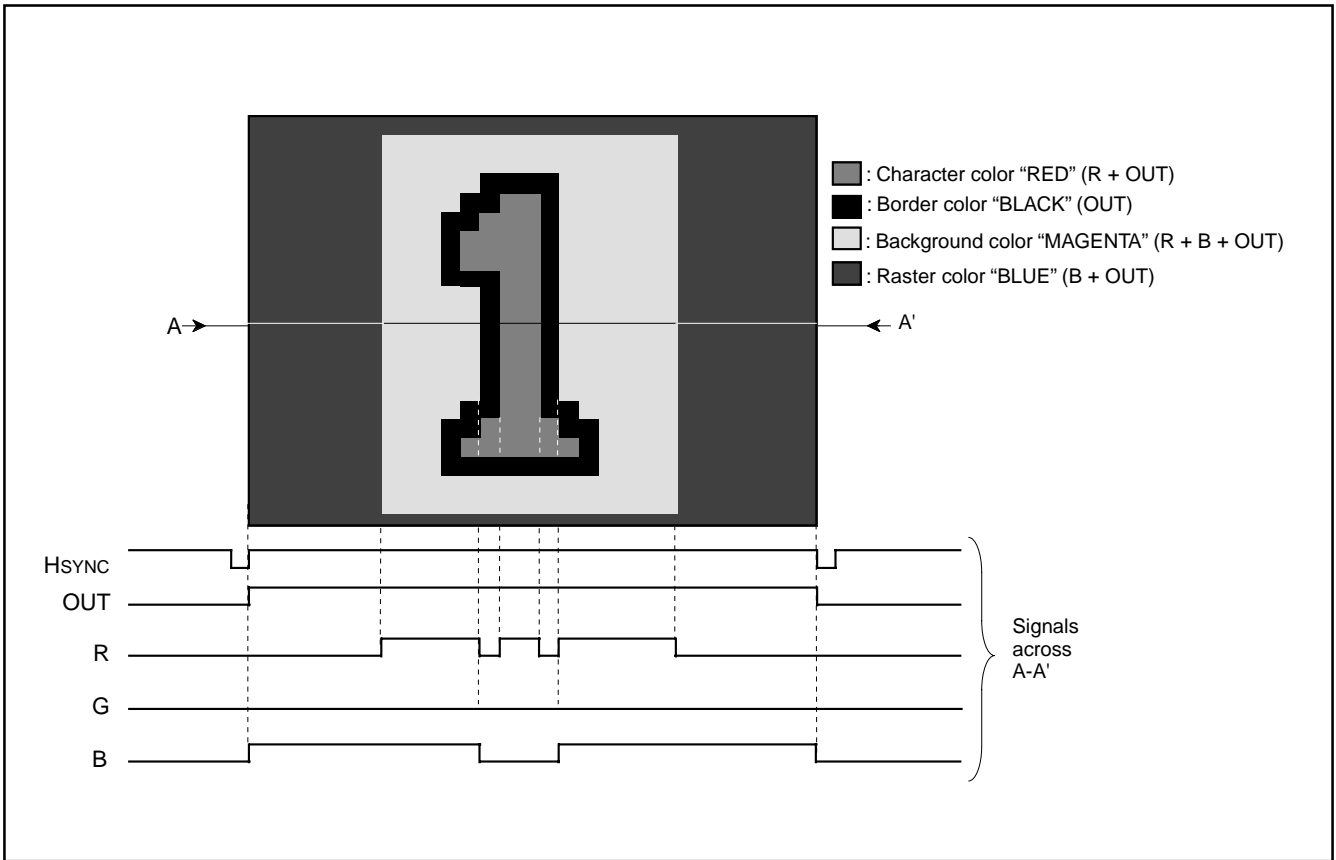

Fig. 8.11.31 Example of Raster Coloring

M37151M6/M8/MA/MC/MF-XXXFP, M37151EFP

SINGLE-CHIP 8-BIT CMOS MICROCOMPUTER with CLOSED CAPTION DECODER and ON-SCREEN DISPLAY CONTROLLER

8.12 SOFTWARE RUNAWAY DETECT FUNCTION

This microcomputer has a function to decode undefined instructions to detect a software runaway.

When an undefined op-code is input to the CPU as an instruction code during operation, the following processing is done.

- ① The CPU generates an undefined instruction decoding signal.
- ② The device is internally reset due to the undefined instruction decoding signal.
- ③ As a result of internal reset, the same reset processing as in the case of ordinary reset operation is done, and the program restarts from the reset vector.

Note, however, that the software runaway detecting function cannot be disabled.

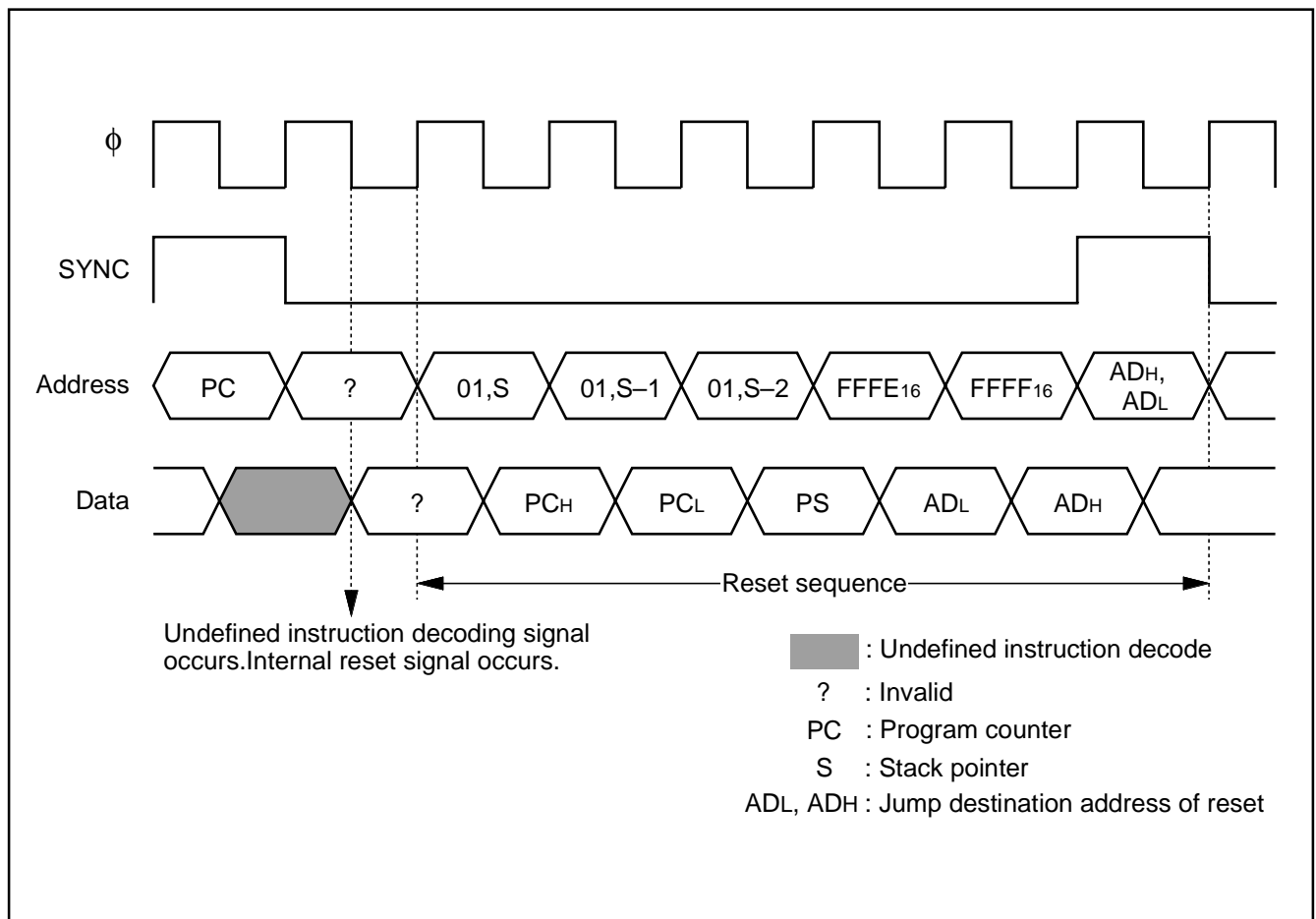

Fig.8.12.1 Sequence at Detecting Software Runaway Detection

M37151M6/M8/MA/MC/MF-XXXFP, M37151EFP

SINGLE-CHIP 8-BIT CMOS MICROCOMPUTER with CLOSED CAPTION DECODER and ON-SCREEN DISPLAY CONTROLLER

8.13. RESET CIRCUIT

When the oscillation of a quartz-crystal oscillator or a ceramic resonator is stable and the power source voltage is $5\text{ V} \pm 10\%$, hold the $\overline{\text{RESET}}$ pin at LOW for $2\ \mu\text{s}$ or more, then return to HIGH. Then, as shown in Figure 8.13.2, reset is released and the program starts from the address formed by using the content of address FFFF_{16} as the high-order address and the content of the address FFFE_{16} as the low-order address. The internal states of the microcomputer at reset are shown in Figures 8.2.2 to 8.2.5.

An example of the reset circuit is shown in Figure 8.13.1. The reset input voltage must be kept 0.9 V or less until the power source voltage surpasses 4.5 V.

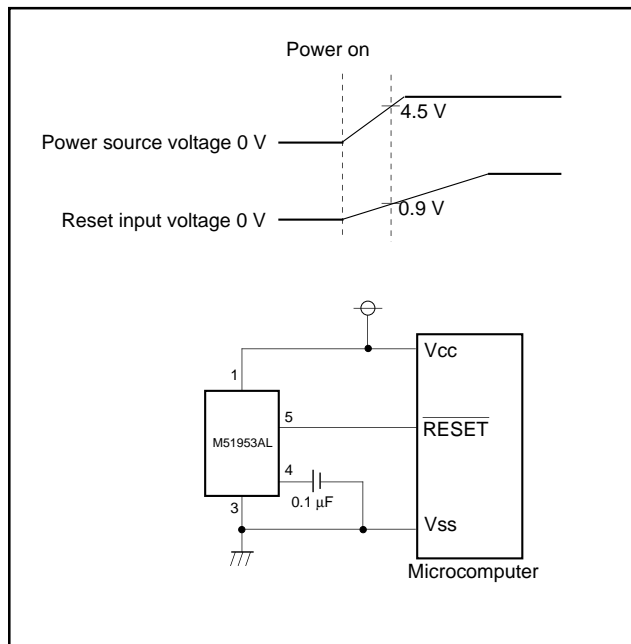

Fig.8.13.1 Example of Reset Circuit

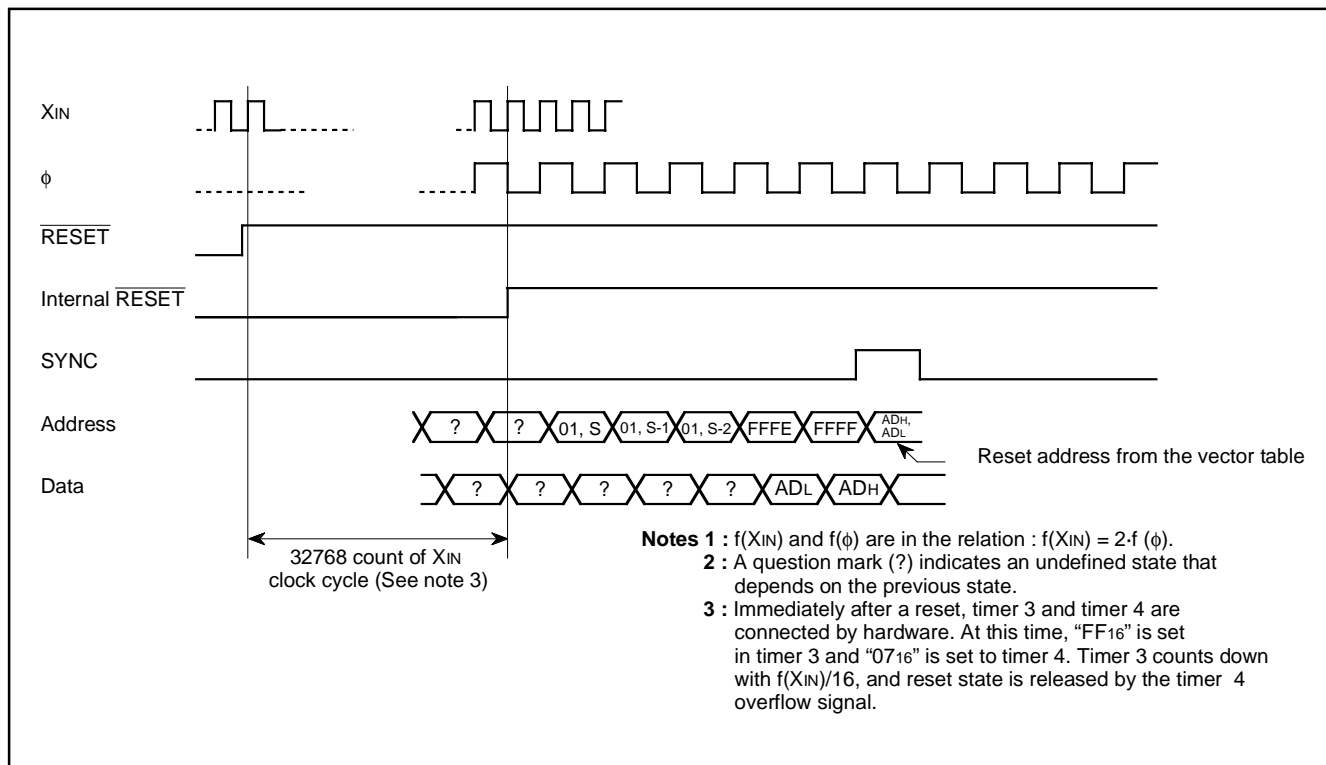

Fig.8.13.2 Reset Sequence

M37151M6/M8/MA/MC/MF-XXXFP, M37151EFFP

SINGLE-CHIP 8-BIT CMOS MICROCOMPUTER with CLOSED CAPTION DECODER
and ON-SCREEN DISPLAY CONTROLLER

8.14 CLOCK GENERATING CIRCUIT

This microcomputer has 2 built-in oscillation circuits. An oscillation circuit can be formed by connecting a resonator between XIN and XOUT (XCIN and XCOUT). Use the circuit constants in accordance with the resonator manufacturer's recommended values. No external resistor is needed between XIN and XOUT since a feed-back resistor exists on-chip. However, an external feed-back resistor is needed between XCIN and XCOUT. When using XCIN-XCOUT as sub-clock, clear bits 5 and 6 of the OSD control register to "0." To supply a clock signal externally, input it to the XIN (XCIN) pin and make the XOUT (XCOUT) pin open. When not using XCIN clock, connect the XCIN to Vss and make the XCOUT pin open.

The OSD clock can be chosen to be the data slicer clock (approx. 26 MHz) that is output from the data slicer.

After reset has completed, the internal clock ϕ is half the frequency of XIN. Immediately after poweron, both the XIN and XCIN clock start oscillating. To set the internal clock ϕ to low-speed operation mode, set bit 7 of the CPU mode register to "1."

8.14.1 OSCILLATION CONTROL

(1) Stop Mode

The built-in clock generating circuit is shown in Figure 120. When the STP instruction is executed, the internal clock f stops at HIGH. At the same time, timers 3 and 4 are connected by hardware and "FF16" is set in timer 3 and "0716" is set in timer 4. Select $f(XIN)/16$ or $f(XCIN)/16$ as the timer 3 count source (set both bit 0 of timer mode register 2 and bit 6 at address 00C716 to "0" before the execution of the STP instruction). Moreover, set the timer 3 and timer 4 interrupt enable bits to disabled ("0") before execution of the STP instruction. The oscillator restarts when an external interrupt is accepted. However, the internal clock f keeps its HIGH level until timer 4 overflows, allowing time for oscillation stabilization when a ceramic resonator or a quartz-crystal oscillator is used.

By setting bit 7 of timer return setting register (address 00CC16) to "1," an arbitrary value can be set to timer 3 and timer 4.

Bit 7 of clock control register 3 (address 020216) can switch Port P10 pin and the CLKCONT pin is selected, "H" is output normally. When an external interrupt is received in the STP state, the CLKCONT pin goes back to "H" output.

(2) Wait Mode

When the WIT instruction is executed, the internal clock ϕ stops in the HIGH level but the oscillator continues running. This wait state is released at reset or when an interrupt is accepted (See note). Since the oscillator does not stop, the next instruction can be executed immediately.

Note: In the wait mode, the following interrupts are invalid.

- VSYNC interrupt
- OSD interrupt
- All timer interrupts using external clock input from port pin as count source
- All timer interrupts using $f(XIN)/2$ or $f(XCIN)/2$ as count source
- All timer interrupts using $f(XIN)/4096$ or $f(XCIN)/4096$ as count source
- $f(XIN)/4096$ interrupt
- Multi-master I²C-BUS interface interrupt
- Data slicer interrupt
- A-D conversion interrupt

(3) Low-speed Mode

If the internal clock is generated from the sub-clock (XCIN), a low power consumption operation can be realized by stopping only the main clock XIN. To stop the main clock, set bit 6 (CM6) of the CPU mode register (00FB16) to "1." When the main clock XIN is restarted, the program must allow enough time for oscillation to stabilize.

Note that in the low-power-consumption mode the XCIN-XCOUT drivability can be reduced, allowing even lower power consumption. To reduce the XCIN-XCOUT drivability, clear bit 5 (CM5) of the CPU mode register (00FB16) to "0." At reset, this bit is set to "1" and strong drivability is selected to help the oscillation to start. When executing an STP instruction, set this bit to "1" by software before initiating the instruction.

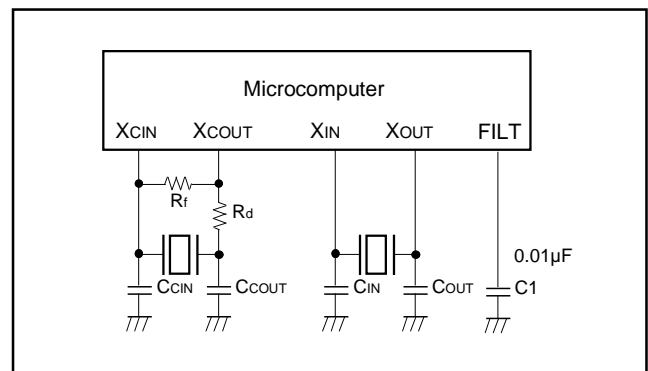

Fig.8.14.1 Ceramic Resonator Circuit Example

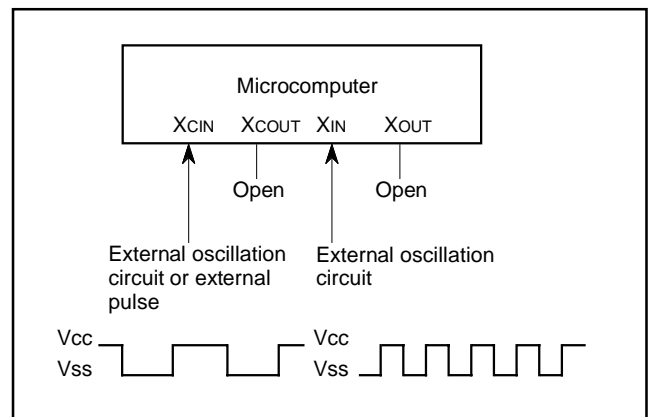

Fig.8.14.2 External Clock Input Circuit Example

M37151M6/M8/MA/MC/MF-XXXFP, M37151EFP

SINGLE-CHIP 8-BIT CMOS MICROCOMPUTER with CLOSED CAPTION DECODER
and ON-SCREEN DISPLAY CONTROLLER

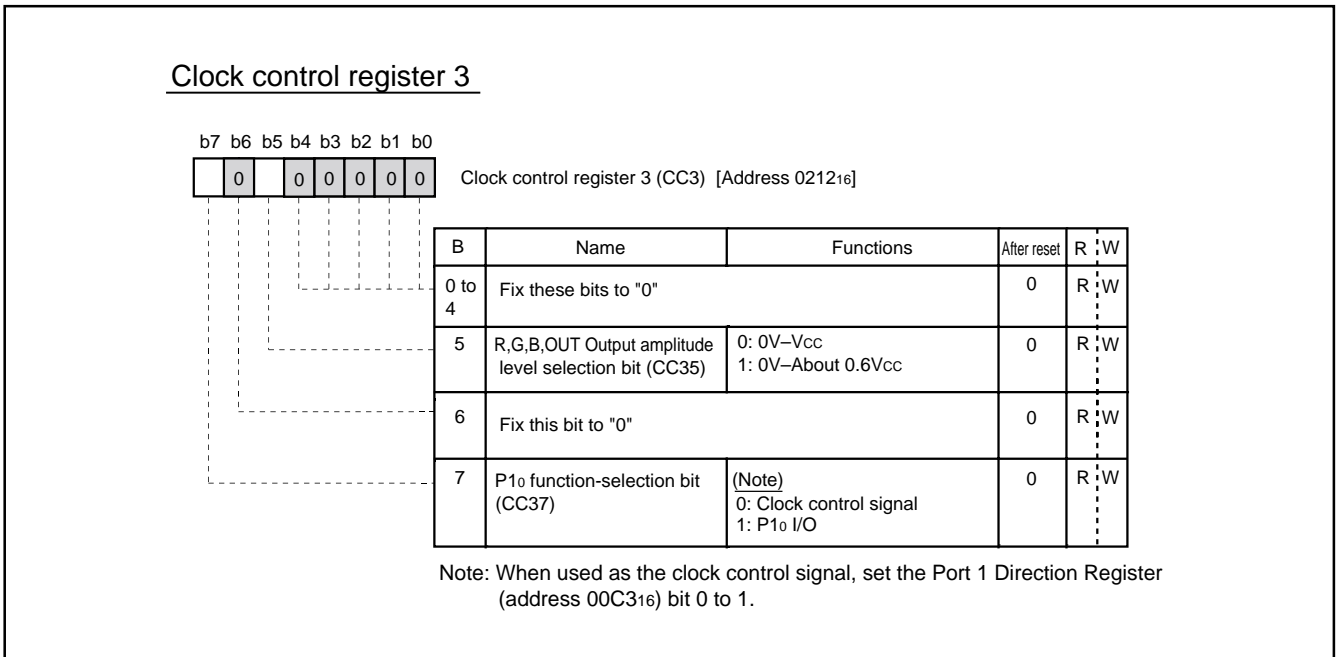

Fig.8.14.3 Clock Control Register 3

M37151M6/M8/MA/MC/MF-XXXFP, M37151EFFP

SINGLE-CHIP 8-BIT CMOS MICROCOMPUTER with CLOSED CAPTION DECODER
and ON-SCREEN DISPLAY CONTROLLER

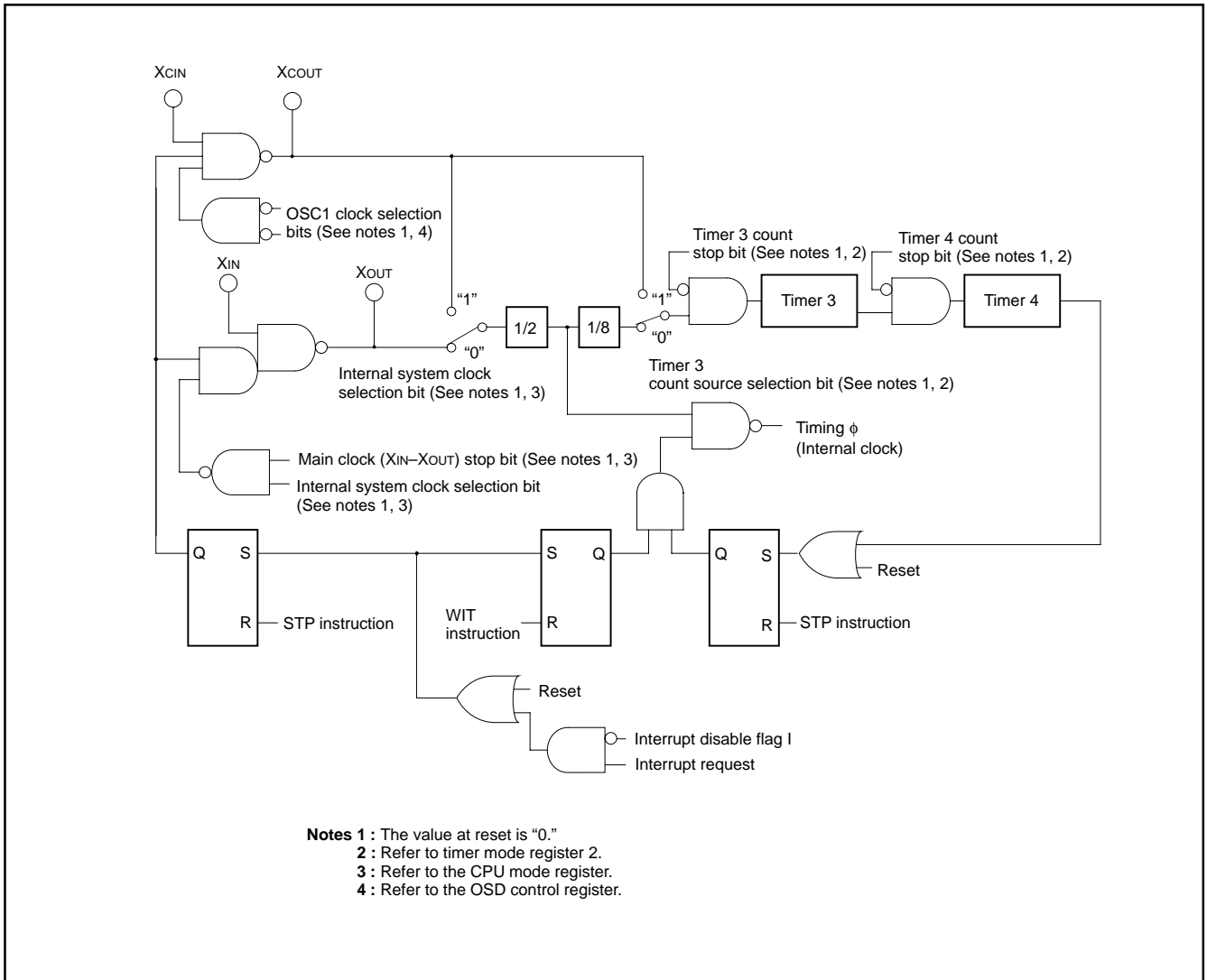

Fig.8.14.4 Clock Generating Circuit Block Diagram

M37151M6/M8/MA/MC/MF-XXXFP, M37151EFP

SINGLE-CHIP 8-BIT CMOS MICROCOMPUTER with CLOSED CAPTION DECODER and ON-SCREEN DISPLAY CONTROLLER

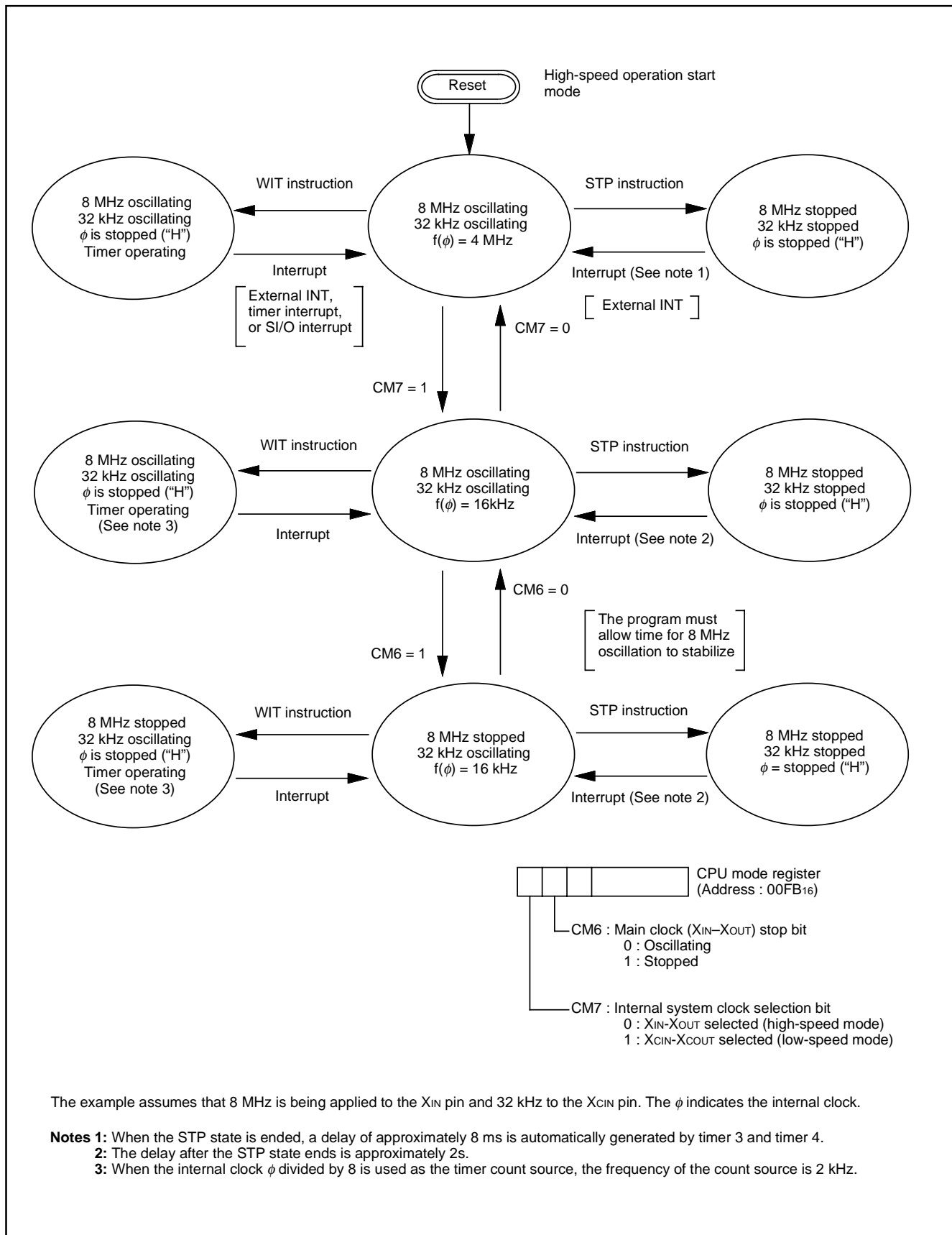

Fig.8.14.5 State Transitions of System Clock

M37151M6/M8/MA/MC/MF-XXXFP, M37151EFFP

SINGLE-CHIP 8-BIT CMOS MICROCOMPUTER with CLOSED CAPTION DECODER and ON-SCREEN DISPLAY CONTROLLER

8.15 OSD CLOCK GENERATING CIRCUIT

When generate OSD clock based on main clock, connect capacity to FILT pin.

Set bit 0 of the clock control register 1 (address 00CD₁₆) to operate OSD clock generating circuit "0." Clock control register 1 (address 00CD₁₆) is shown in Fig.8.15.3. Then, clock frequency for OSD is set up by the clock frequency register (address 0210₁₆).

Clock frequency setting register is shown in Fig.8.15.2.

In order to generate normally oscillation frequency for OSD shown in Table 8.15.1, be sure to set the main clock f (X_{IN}) to 8MHz. Then, set up not any values other than these.

Table.8.15.1 OSD Clock frequency

Clock frequency setting register (address 0210 ₁₆)	0C	0D
OSD clock frequency	26 MHz	28 MHz

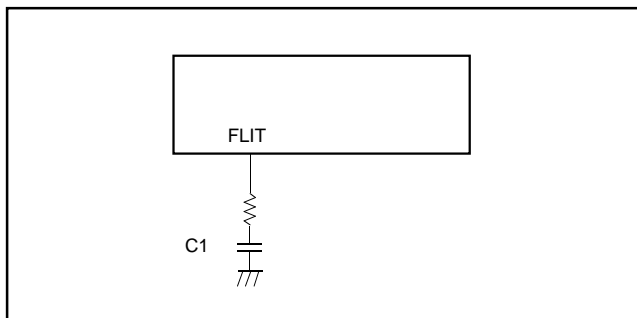

Fig.8.15.1 Display Oscillation Circuit

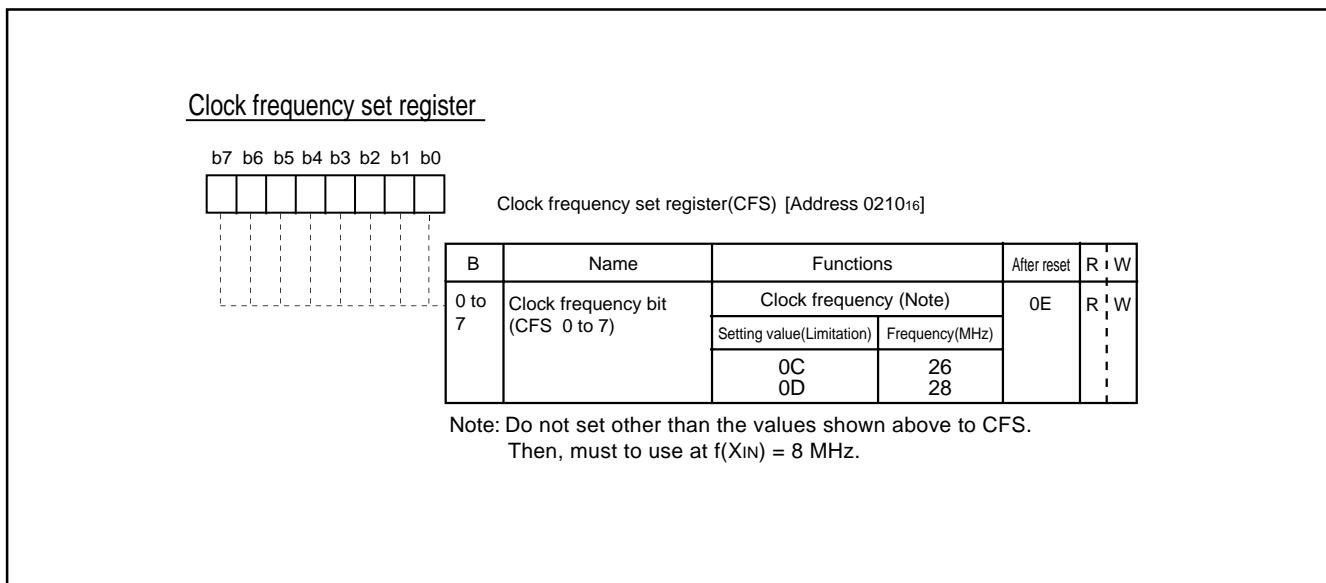

Fig.8.15.2 Clock Frequency Register

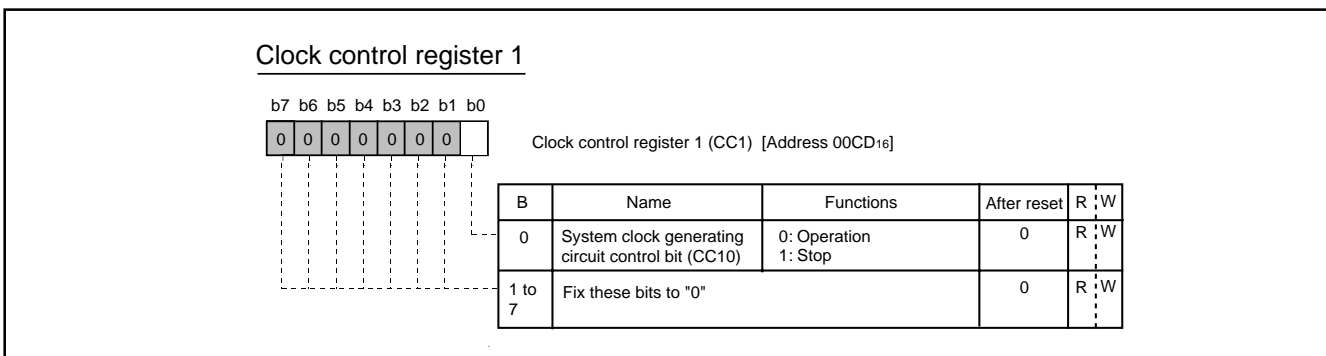

Fig.8.15.3 Clock Control Register 1

M37151M6/M8/MA/MC/MF-XXXFP, M37151EFP

SINGLE-CHIP 8-BIT CMOS MICROCOMPUTER with CLOSED CAPTION DECODER
and ON-SCREEN DISPLAY CONTROLLER

8.16 AUTO-CLEAR CIRCUIT

When a power source is supplied, the auto-clear function will operate by connecting the following circuit to the RESET pin.

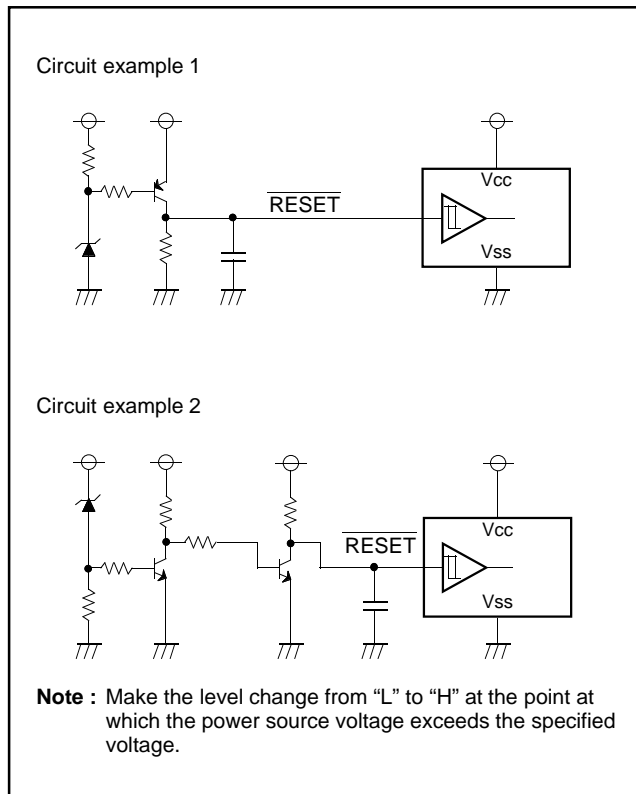

Fig.8.16.1 Auto-clear Circuit Example

8.17 ADDRESSING MODE

The memory access is reinforced with 17 kinds of addressing modes. Refer to SERIES 740 <Software> User's Manual for details.

8.18 MACHINE INSTRUCTIONS

There are 71 machine instructions. Refer to SERIES 740 <Software> User's Manual for details.

9. TECHNICAL NOTES

- The divide ratio of the timer is $1/(n+1)$.
- Even though the BBC and BBS instructions are executed immediately after the interrupt request bits are modified (by the program), those instructions are only valid for the contents before the modification. At least one instruction cycle is needed (such as an NOP) between the modification of the interrupt request bits and the execution of the BBC and BBS instructions.
- After the ADC and SBC instructions are executed (in the decimal mode), one instruction cycle (such as an NOP) is needed before the SEC, CLC, or CLD instruction is executed.
- An NOP instruction is needed immediately after the execution of a PLP instruction.
- In order to avoid noise and latch-up, connect a bypass capacitor ($\approx 0.1\mu\text{F}$) directly between the Vcc pin-Vss pin and the Vcc pin-CNVss pin, using a thick wire.
- Characteristic value, margin of operation, etc. of versions with built-in EPROM and built-in mask ROM may differ from each other within the limits of the electrical characteristics in terms of manufacturing process, built-in ROM, difference of a layout pattern, etc.

Carry out and check an examination equivalent to the system evaluation examination carried out on the EPROM version when replacing it with the mask ROM version.

M37151M6/M8/MA/MC/MF-XXXFP, M37151EFFP

SINGLE-CHIP 8-BIT CMOS MICROCOMPUTER with CLOSED CAPTION DECODER
and ON-SCREEN DISPLAY CONTROLLER

10. ABSOLUTE MAXIMUM RATINGS

Symbol	Parameter	Conditions	Ratings	Unit
VCC	Power source voltage VCC	All voltages are based on Vss. Output transistors are cut off.	-0.3 to 6	V
VI	Input voltage CNVss		-0.3 to 6	V
VI	Input voltage P00-P07, P10-P16, P20-P27, P30, P31, P50, P51, RESET, CVIN		-0.3-VCC + 0.3	V
VO	Output voltage P06, P07, P10-P16, P20-P27, P30, P31, P52-P55		-0.3-VCC + 0.3	V
IOH	Circuit current P10-P16, P20-P27, P30, P31, P52-P55,		0 to 1 (See note 1)	mA
IOL1	Circuit current P00-P07, P10-P15, P16, P20-P23, P52-P55,		0 to 2 (See note 2)	mA
IOL2	Circuit current P11-P14, P30, P31		0 to 6 (See note 2)	mA
IOL4	Circuit current P24-P27		0 to 10 (See note 3)	mA
Pd	Power dissipation	Ta = 25 °C	550	mW
Topr	Operating temperature		-10 to 70	°C
Tstg	Storage temperature		-40 to 125	°C

11. RECOMMENDED OPERATING CONDITIONS (Ta = -10 °C to 70 °C, VCC = 5 V ± 10 %, unless otherwise noted)

Symbol	Parameter	Limits			Unit
		Min.	Typ.	Max.	
VCC	Power source voltage (See note 4)	4.5	5.0	5.5	V
VSS	Power source voltage	0	0	0	V
VIH1	HIGH Input voltage P00-P07, P10-P16, P20-P27, P30, P31, P50, P51, RESET	0.8VCC		VCC	V
VIH2	HIGH Input voltage SCL1, SCL2, SCL3, SDA1, SDA2, SDA3 (When using I ² C-BUS)	0.7VCC		VCC	V
VIL1	LOW Input voltage P00-P07, P10-P16, P20-P27, P30, P31	0		0.4VCC	V
VIL2	LOW Input voltage SCL1, SCL2, SCL3, SDA1, SDA2, SDA3 (When using I ² C-BUS)	0		0.3VCC	V
VIL3	LOW Input voltage (See note 6) P50, P51, RESET, TIM2, TIM3, INT1, INT2, INT3, SIN, SCLK	0		0.2VCC	V
IOH	HIGH average output current (See note 1) P10-P16, P20-P27, P30, P31, P52-P55			1	mA
IOL1	HIGH average output current (See note 2) P00-P07, P10, P15, P16, P20-P23, P52-P55			2	mA
IOL2	LOW average output current (See note 2) P11-P14, P30, P31			6	mA
IOL3	LOW average output current (See note 3) P24-P27			10	mA
f(XIN)	Oscillation frequency (for CPU operation) (See note 5) XIN	7.9	8.0	8.1	MHz
f(XCIN)	Oscillation frequency (for sub-clock operation) XCIN	29	32	35	kHz
fhs1	Input frequency TIM2, TIM3, INT1, INT2, INT3			100	kHz
fhs2	Input frequency SCLK			1	MHz
fhs3	Input frequency SCL1, SCL2			447.5	kHz
fhs4	Input frequency Horizontal sync. signal of video signal	15.262	15.734	16.206	kHz
VI	Input amplitude video signal CVIN	1.5	2.0	2.5	V

M37151M6/M8/MA/MC/MF-XXXFP, M37151EFP

SINGLE-CHIP 8-BIT CMOS MICROCOMPUTER with CLOSED CAPTION DECODER
and ON-SCREEN DISPLAY CONTROLLER

12. ELECTRIC CHARACTERISTICS (VCC = 5 V ± 10 %, VSS = 0 V, f(XIN) = 8 MHz, Ta = -10 °C to 70 °C, unless otherwise noted)

Symbol	Parameter		Test conditions		Limits			Unit	Test circuit	
					Min.	Typ.	Max.			
Icc	Power source current	System operation	VCC = 5.5V, f(XIN) = 8 MHz	OSD OFF Data slicer OFF		15	30	mA	1	
				OSD ON Data slicer ON		30	45			
			VCC = 5.5V, f(XIN) = 0, f(XCIN) = 32kHz, OSD OFF, Data slicer OFF, Low-power dissipation mode set (CM5 = "0", CM6 = "1")			60	200	μA		
			Wait mode	VCC = 5.5 V, f(XIN) = 8 MHz			1	2		mA
				VCC = 5.5 V, f(XIN) = 0, f(XCIN) = 32 kHz, Low-power dissipation mode set (CM5 = "0", CM6 = "1")			25	100		μA
Stop mode	VCC = 5.5V, f(XIN) = 0, f(XCIN) = 0			1	10					
VOH	HIGH output voltage	P10–P16, P20–P27, P30, P31, P52–P55,	VCC = 4.5 V IOH = -0.5 mA		2.4			V	2	
VOL	LOW output voltage	P00–P07, P10, P15, P16, P20–P23, P52–P55	VCC = 4.5 V IOL = 0.5 mA				0.4	V		
	LOW output voltage	P24– P27	VCC = 4.5 V IOL = 10.0 mA				3.0			
	LOW output voltage	P11–P14, P30, P32	VCC = 4.5 V	IOL = 3 mA			0.4			
				IOL = 6 mA			0.6			
VT+ -VT-	Hysteresis (See note 6) RESET, P50, P51, INT1, INT2, INT3, TIM2, TIM3, SIN, SCLK, SCL1, SCL2, SCL3, SDA1, SDA2, SDA3		VCC = 5.0 V			0.5	1.3	V	3	
IIZH	HIGH input leak current P00–P07, P10–P16, P20–P27, P30, P31, RESET, P50, P51,		VCC = 5.5 V VI = 5.5 V				5	μA	4	
IIZL	HIGH input leak current P00–P07, P10–P16, P20–P27, P30, P31, P50, P51, RESET		VCC = 5.5 V VI = 0 V				5	μA	4	
RBS	I ² C-BUS • BUS switch connection resistor (between SCL1 and SCL2, SDA1 and SDA2)		VCC = 4.5 V				130	Ω	5	

- Notes**
- 1: The total current that flows out of the IC must be 20 mA or less.
 - 2: The total input current to IC (IOL1 + IOL2) must be 30 mA or less.
 - 3: The total average input current for ports P24–P27 and AVCC–VSS to IC must be 20 mA or less.
 - 4: Connect 0.1 μF or more capacitor externally between the power source pins VCC–VSS so as to reduce power source noise.
Also connect 0.1 μF or more capacitor externally between the pins VCC–CNVSS.
 - 5: P06, P07, P16, P23, P24, P25 have hysteresis when used as interrupt input pins or timer input pins. P11–P14, P30, P31 have hysteresis when used as multi-master I²C-BUS interface ports. P20–P22 have hysteresis when used as serial I/O pins.
 - 6: Pin names in each parameter are described as below.
 - (1) Dedicated pins: dedicated pin names.
 - (2) Double-/triple-function ports
 - Same limits: I/O port name.
 - Functions other than ports vary from I/O port limits: function pin name.

M37151M6/M8/MA/MC/MF-XXXFP, M37151EFFP

SINGLE-CHIP 8-BIT CMOS MICROCOMPUTER with CLOSED CAPTION DECODER
and ON-SCREEN DISPLAY CONTROLLER

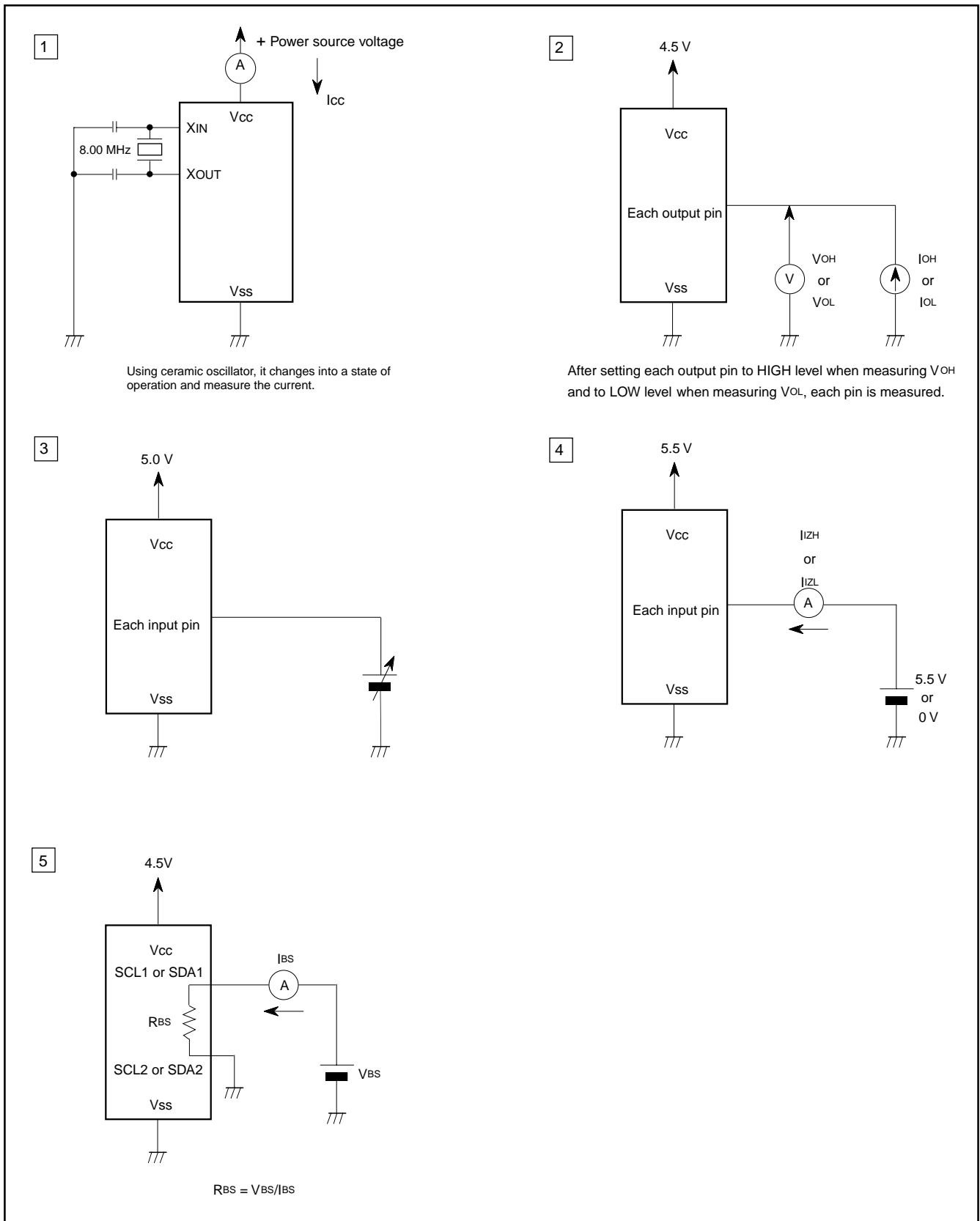

Fig.12.1 Measurement Circuits

M37151M6/M8/MA/MC/MF-XXXFP, M37151EFP

SINGLE-CHIP 8-BIT CMOS MICROCOMPUTER with CLOSED CAPTION DECODER
and ON-SCREEN DISPLAY CONTROLLER

13. A-D CONVERTER CHARACTERISTICS

(VCC = 5 V ± 10 %, VSS = 0 V, f(XIN) = 8 MHz, Ta = -10 °C to 70 °C, unless otherwise noted)

Symbol	Parameter	Test conditions	Limits			Unit
			Min.	Typ.	Max.	
—	Resolution				7	bits
—	Non-linearity error				±1.5	LSB
—	Differential non-linearity error				±0.9	LSB
V0T	Zero transition error	IOL (SUM) = 0 mA			2	LSB
VFST	Full-scale transition error				-2	LSB

14. MULTI-MASTER I²C-BUS BUS LINE CHARACTERISTICS

Symbol	Parameter	Standard clock mode		High-speed clock mode		Unit
		Min.	Max.	Min.	Max.	
tBUF	Bus free time	4.7		1.3		μs
tHD; STA	Hold time for START condition	4.0		0.6		μs
tLOW	LOW period of SCL clock	4.7		1.3		μs
tR	Rising time of both SCL and SDA signals		1000	20+0.1Cb	300	ns
tHD; DAT	Data hold time	0		0	0.9	μs
tHIGH	HIGH period of SCL clock	4.0		0.6		μs
tF	Falling time of both SCL and SDA signals		300	20+0.1Cb	300	ns
tSU; DAT	Data set-up time	250		100		ns
tSU; STA	Set-up time for repeated START condition	4.7		0.6		μs
tSU; STO	Set-up time for STOP condition	4.0		0.6		μs

Note: Cb = total capacitance of 1 bus line

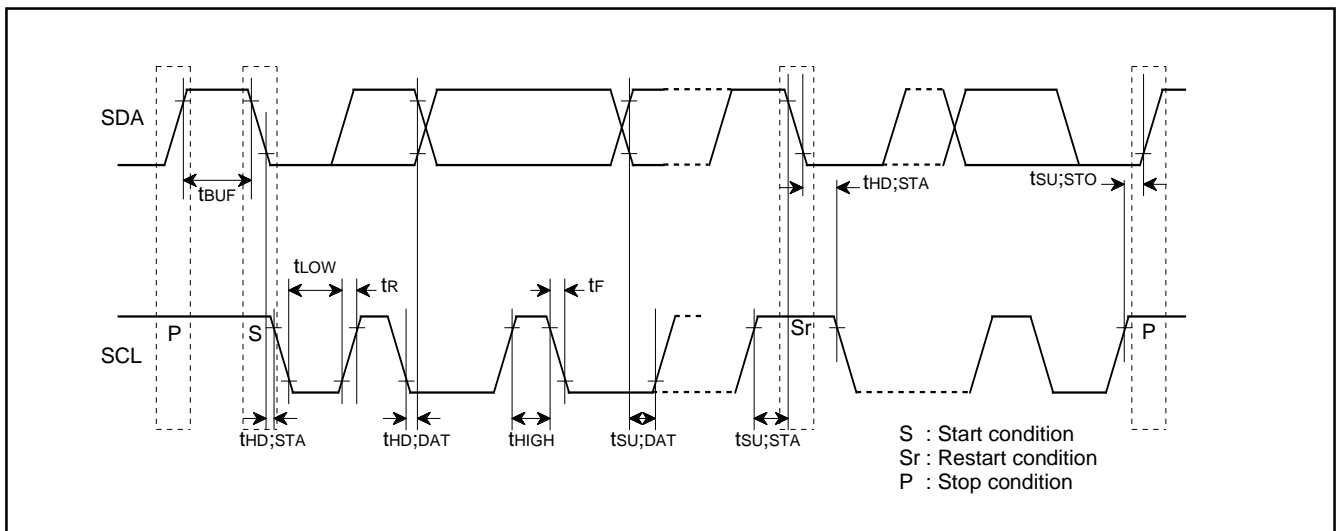

Fig.14.1 Definition Diagram of Timing on Multi-master I²C-BUS

M37151M6/M8/MA/MC/MF-XXXFP, M37151EFP

SINGLE-CHIP 8-BIT CMOS MICROCOMPUTER with CLOSED CAPTION DECODER
and ON-SCREEN DISPLAY CONTROLLER

15. PROM PROGRAMMING METHOD

The built-in PROM of the One Time PROM version (blank) and the built-in EPROM version can be read or programmed with a general-purpose PROM programmer using a special programming adapter.

Product	Name of Programming Adapter
M37151EFP	PCA7450FP

The PROM of the One Time PROM version (blank) is not tested or screened in the assembly process nor any following processes. To ensure proper operation after programming, the procedure shown in Figure 15.1 is recommended to verify programming.

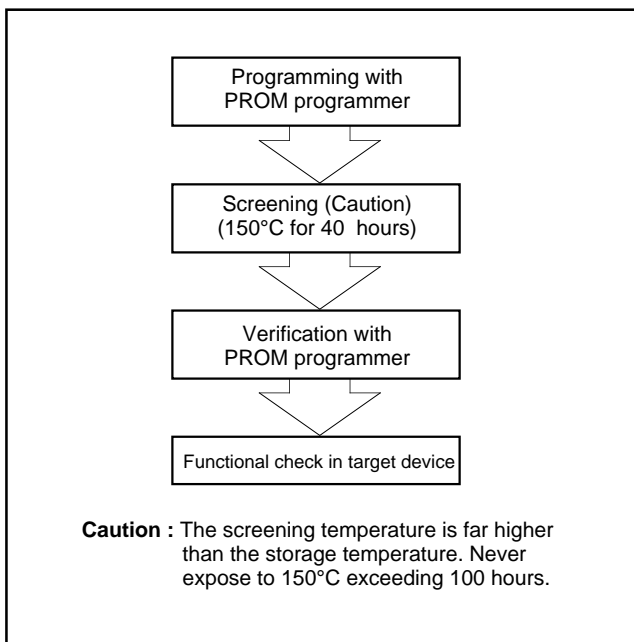

Fig. 15.1 Programming and Testing of One Time PROM Version

16. DATA REQUIRED FOR MASK ORDERS

The following are necessary when ordering a mask ROM product:

- Mask ROM Order Confirmation Form
- Mark Specification Form
- Data to be written to ROM, in EPROM form (three identical copies) or FDK

When using EPROM:

Three sets of 32-pin DIP Type 27C101

M37151M6/M8/MA/MC/MF-XXXFP, M37151EFP

SINGLE-CHIP 8-BIT CMOS MICROCOMPUTER with CLOSED CAPTION DECODER
and ON-SCREEN DISPLAY CONTROLLER

17. ONE TIME PROM VERSION M37151EFP MARKING

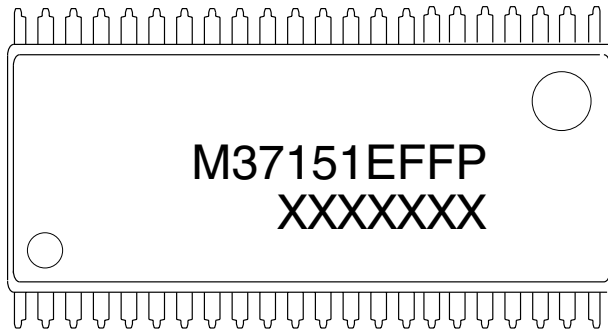

XXXXXXX is mitsubishi lot number

M37151M6/M8/MA/MC/MF-XXXFP, M37151EFFP

SINGLE-CHIP 8-BIT CMOS MICROCOMPUTER with CLOSED CAPTION DECODER
and ON-SCREEN DISPLAY CONTROLLER

18. APPENDIX Pin Configuration (TOP VIEW)

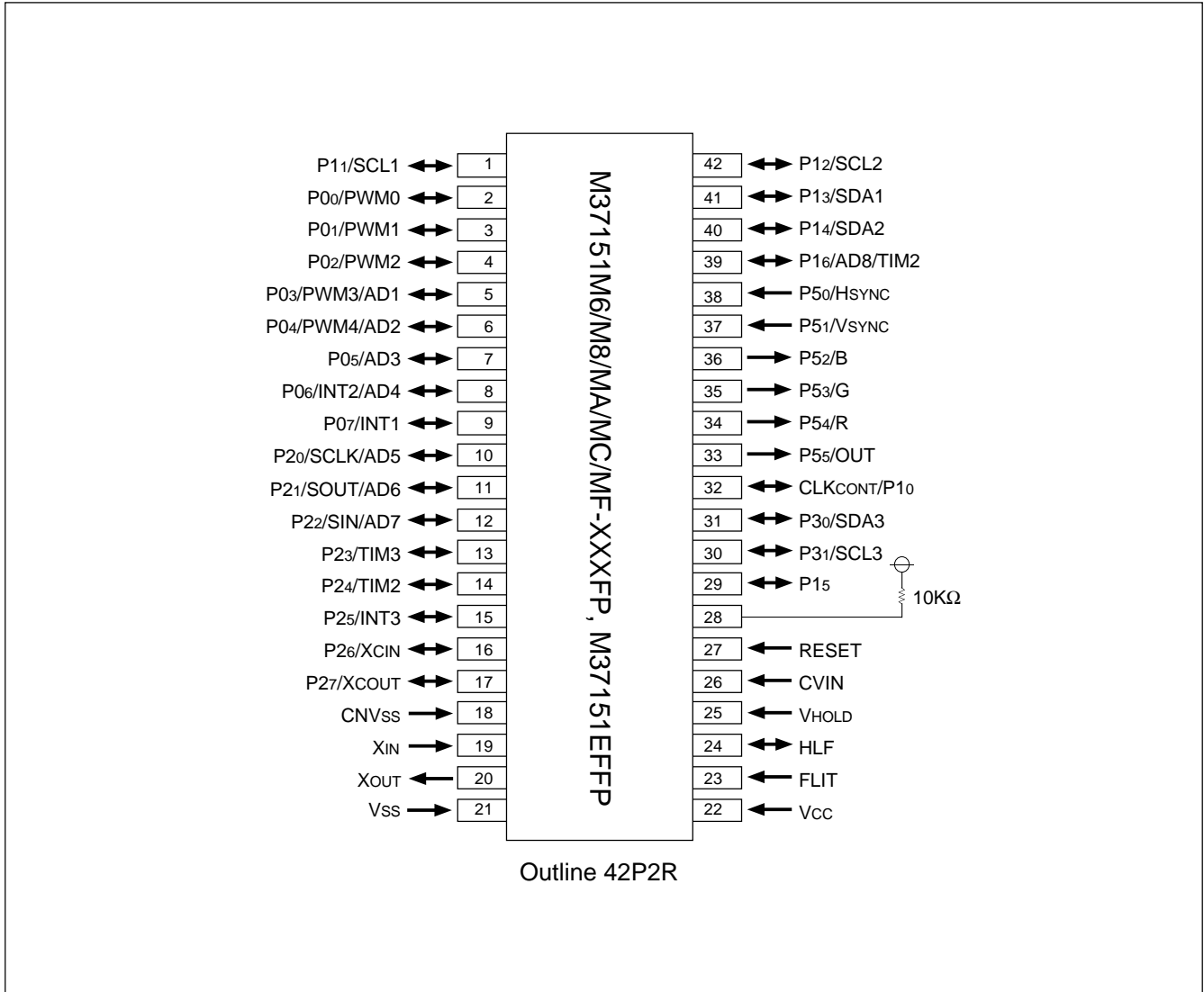

M37151M6/M8/MA/MC/MF-XXXFP, M37151EFP

SINGLE-CHIP 8-BIT CMOS MICROCOMPUTER with CLOSED CAPTION DECODER and ON-SCREEN DISPLAY CONTROLLER

Memory Map

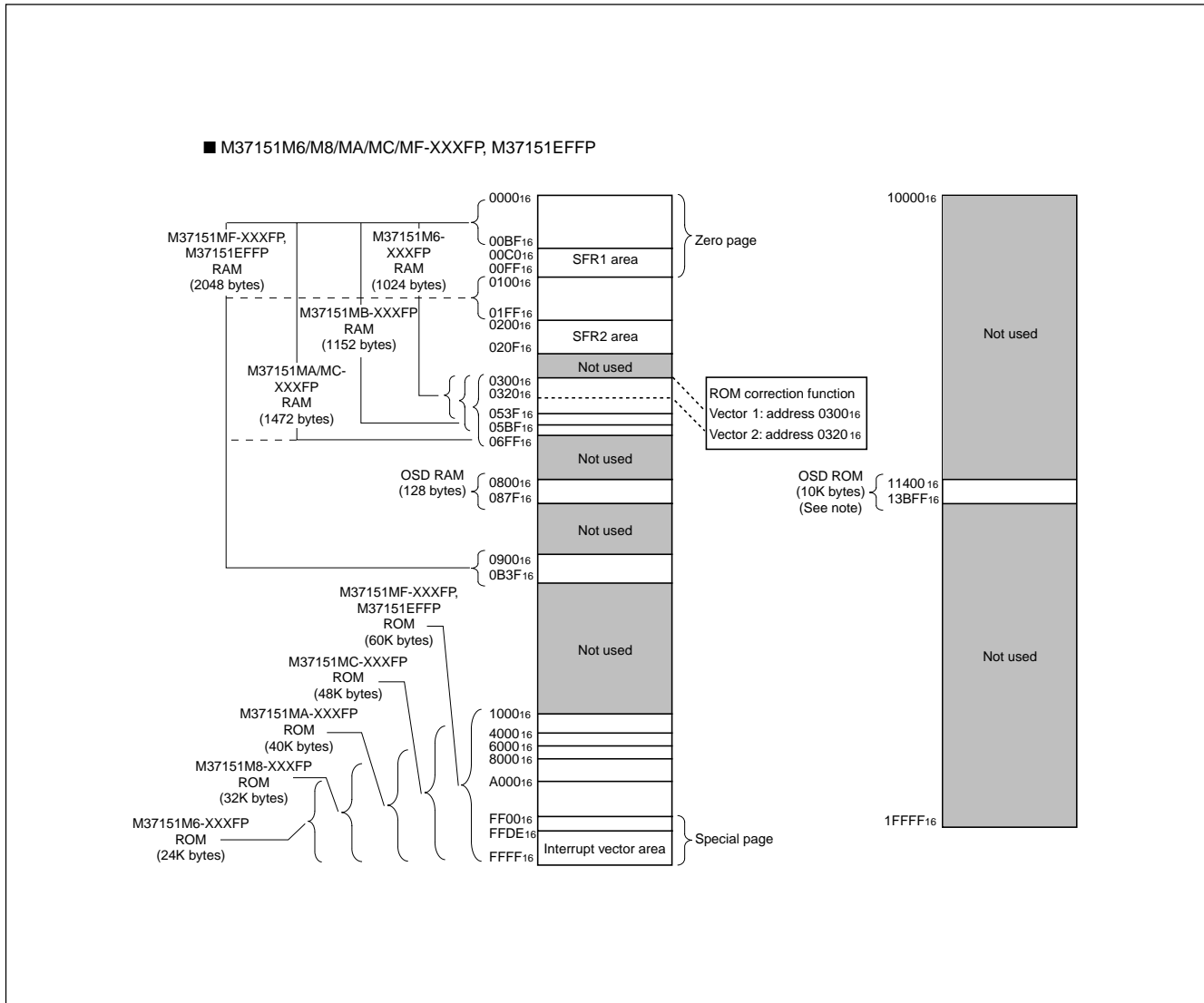

M37151M6/M8/MA/MC/MF-XXXFP, M37151EFFP

SINGLE-CHIP 8-BIT CMOS MICROCOMPUTER with CLOSED CAPTION DECODER
and ON-SCREEN DISPLAY CONTROLLER

Memory Map of Special Function Register (SFR)

■ SFR1 Area (addresses C0₁₆ to DF₁₆)

<Bit allocation>

- : } Function bit
- Name : }
- : No function bit
- : Fix this bit to 0
(do not write 1)
- : Fix this bit to 1
(do not write 0)

<State immediately after reset>

- : 0 immediately after reset
- : 1 immediately after reset
- : Indeterminate immediately after reset

Address	Register	Bit allocation								State immediately after reset							
		b7							b0	b7							b0
C0 ₁₆	Port P0(P0)									?							
C1 ₁₆	Port P0 direction register (D0)	00 ₁₆								?							
C2 ₁₆	Port P1(P1)	0								?	?	0	?	?	?	?	?
C3 ₁₆	Port P1 direction register (D1)	0								0	0	1	0	0	0	0	1
C4 ₁₆	Port P2(P2)									?							
C5 ₁₆	Port P2 direction register (D2)	00 ₁₆								?							
C6 ₁₆	Port P3(P3)					BSEL21	BSEL20	P31	P30	0	0	0	0	0	0	?	?
C7 ₁₆	Port P3 direction register (D3)	T2SC	T3SC			0	OUTS	P31D	P30D	00 ₁₆							
C8 ₁₆		0	0	0	0	0	0	0	0	?							
C9 ₁₆		0	0	1	1	1	1	1	1	?							
CA ₁₆	Port P5(P5)	0	0					0	0	?							
CB ₁₆	OSD port control register (PF)	1	0	PF5	PF4	PF3	PF2	0	0	0	?	0	0	0	0	0	0
CC ₁₆	Timer return set register (TMS)	TMS	1	1	0	0	0	0	0	00 ₁₆							
CD ₁₆	Clock control register 1 (CC1)	0	0	0	0	0	0	0	CC10	00 ₁₆							
CE ₁₆	Caption data register 3 (CD3)	CDL27	CDL26	CDL25	CDL24	CDL23	CDL22	CDL21	CDL20	?							
CF ₁₆	Caption data register 4 (CD4)	CDH27	CDH26	CDH25	CDH24	CDH23	CDH22	CDH21	CDH20	?							
D0 ₁₆	OSD control register (OC)	OC7	0	0	OC4	OC3	OC2	OC1	OC0	00 ₁₆							
D1 ₁₆	Horizontal position register (HP)		HP6	HP5	HP4	HP3	HP2	HP1	HP0	00 ₁₆							
D2 ₁₆	Block control register 1(BC1)	BC17	BC16	BC15	BC14	BC13	BC12	BC11	BC10	?							
D3 ₁₆	Block control register 2(BC2)	BC27	BC26	BC25	BC24	BC23	BC22	BC21	BC20	?							
D4 ₁₆	Vertical position register 1(VP1)	VP17	VP16	VP15	VP14	VP13	VP12	VP11	VP10	?							
D5 ₁₆	Vertical position register 2(VP2)	VP27	VP26	VP25	VP24	VP23	VP22	VP21	VP20	?							
D6 ₁₆	Window register 1(WN1)	WN17	WN16	WN15	WN14	WN13	WN12	WN11	WN10	?							
D7 ₁₆	Window register 2(WN2)	WN27	WN26	WN25	WN24	WN23	WN22	WN21	WN20	?							
D8 ₁₆	I/O polarity control register (PC)	0	PC6	PC5	0	PC3	PC2	PC1	PC0	40 ₁₆							
D9 ₁₆	Raster color register (RC)	RC7	0	0	0	RC3	RC2	RC1	RC0	00 ₁₆							
DA ₁₆										?							
DB ₁₆	OSD control register 2(OC2)	0	0	0			0	OC21	OC20	0	0	0	?	0	0	0	0
DC ₁₆	Interrupt input polarity control register (RE)						INT3	INT2	INT1	00 ₁₆							
DD ₁₆		00 ₁₆								00 ₁₆							
DE ₁₆		00 ₁₆								00 ₁₆							
DF ₁₆		00 ₁₆								00 ₁₆							

M37151M6/M8/MA/MC/MF-XXXFP, M37151EFP

SINGLE-CHIP 8-BIT CMOS MICROCOMPUTER with CLOSED CAPTION DECODER
and ON-SCREEN DISPLAY CONTROLLER

■ SFR1 Area (addresses E0₁₆ to FF₁₆)

<Bit allocation>

- : Function bit
- : No function bit
- : Fix this bit to 0 (do not write 1)
- : Fix this bit to 1 (do not write 0)

<State immediately after reset>

- : 0 immediately after reset
- : 1 immediately after reset
- : Indeterminate immediately after reset

Address	Register	Bit allocation								State immediately after reset							
		b7						b0		b7						b0	
E0 ₁₆	Data slicer control register 1 (DSC1)	0	1	1	0	0	DSC12	DSC11	DSC10								00 ₁₆
E1 ₁₆	Data slicer control register 2 (DSC2)		0						1								? 0 ? 0 ? ? 0 ?
E2 ₁₆	Caption data register 1 (CD1)	CDL17	CDL16	CDL15	CDL14	CDL13	CDL12	CDL11	CDL10								00 ₁₆
E3 ₁₆	Caption data register 2 (CD2)	CDH17	CDH16	CDH15	CDH14	CDH13	CDH12	CDH11	CDH10								00 ₁₆
E4 ₁₆	Clock run-in detect register (CRD)	CRD7	CRD6	CRD5	CRD4	CRD3											00 ₁₆
E5 ₁₆	Data clock position register (DPS)	DPS7	DPS6	DPS5	DPS4	DPS3	0	1	0								09 ₁₆
E6 ₁₆	Caption position register (CPS)	CPS7	CPS6	CPS5	CPS4	CPS3	CPS2	CPS1	CPS0	0	0	?	0	0	0	0	0
E7 ₁₆	Data slicer test register 2																00 ₁₆
E8 ₁₆	Data slicer test register 1																00 ₁₆
E9 ₁₆	Synchronous signal counter register (HC)			HC5	HC4	HC3	HC2	HC1	HC0								00 ₁₆
EA ₁₆	Serial I/O register (SIO)																?
EB ₁₆	Serial I/O mode register (SM)	0	SM6	SM5	0	SM3	SM2	SM1	SM0								00 ₁₆
EC ₁₆	A-D control register 1 (AD1)				ADC14		ADC12	ADC11	ADC10	0	0	0	?	0	0	0	0
ED ₁₆	A-D control register 2 (AD2)		ADC26	ADC25	ADC24	ADC23	ADC22	ADC21	ADC20								00 ₁₆
EE ₁₆	Timer 5 (T5)																07 ₁₆
EF ₁₆	Timer 6 (T6)																FF ₁₆
F0 ₁₆	Timer 1 (T1)																FF ₁₆
F1 ₁₆	Timer 2 (T2)																07 ₁₆
F2 ₁₆	Timer 3 (T3)																FF ₁₆
F3 ₁₆	Timer 4 (T4)																07 ₁₆
F4 ₁₆	Timer mode register 1 (TM1)	TM17	TM16	TM15	TM14	TM13	TM12	TM11	TM10								00 ₁₆
F5 ₁₆	Timer mode register 2 (TM2)	TM27	TM26	TM25	TM24	TM23	TM22	TM21	TM20								00 ₁₆
F6 ₁₆	I ² C data shift register (S0)	D7	D6	D5	D4	D3	D2	D1	D0								?
F7 ₁₆	I ² C address register (S0D)	SAD6	SAD5	SAD4	SAD3	SAD2	SAD1	SAD0	RBW								00 ₁₆
F8 ₁₆	I ² C status register (S1)	MST	TRX	BB	PIN	AL	AAS	AD0	LRB	0	0	0	1	0	0	0	?
F9 ₁₆	I ² C control register (S1D)	BSEL1	BSEL0	10BIT SAD	ALS	ESO	BC2	BC1	BC0								00 ₁₆
FA ₁₆	I ² C clock control register (S2)	ACK	ACK BIT	FAST MODE	CCR4	CCR3	CCR2	CCR1	CCR0								00 ₁₆
FB ₁₆	CPU mode register (CPUM)	CM7	CM6	CM5	1	1	CM2	0	0								3C ₁₆
FC ₁₆	Interrupt request register 1 (IREQ1)		IN3R	VSCR	OSDR	TM4R	TM3R	TM2R	TM1R								00 ₁₆
FD ₁₆	Interrupt request register 2 (IREQ2)	0	TM56R	IICR	IN2R	CKR	S1R	DSR	IN1R								00 ₁₆
FE ₁₆	Interrupt control register 1 (ICON1)		IN3E	VSCE	OSDE	TM4E	TM3E	TM2E	TM1E								00 ₁₆
FF ₁₆	Interrupt control register 2 (ICON2)	TM56C	TM56E	IICE	IN2E	CKE	S1E	DSE	IN1E								00 ₁₆

M37151M6/M8/MA/MC/MF-XXXFP, M37151EFFP

SINGLE-CHIP 8-BIT CMOS MICROCOMPUTER with CLOSED CAPTION DECODER
and ON-SCREEN DISPLAY CONTROLLER

■SFR2 Area (addresses 200₁₆ to 20F₁₆)

<Bit allocation>

: } Function bit
 Name : }

: No function bit

0 : Fix this bit to 0
(do not write 1)

1 : Fix this bit to 1
(do not write 0)

<State immediately after reset>

0 : 0 immediately after reset

1 : 1 immediately after reset

? : Indeterminate immediately after reset

Address	Register	Bit allocation						State immediately after reset													
		b7					b0	b7								b0					
200 ₁₆	PWM0 register (PWM0)							?													
201 ₁₆	PWM1 register (PWM1)							?													
202 ₁₆	PWM2 register (PWM2)							?													
203 ₁₆	PWM3 register (PWM3)							?													
204 ₁₆	PWM4 register (PWM4)							?													
205 ₁₆								?													
206 ₁₆		00 ₁₆						?													
207 ₁₆		00 ₁₆						?													
208 ₁₆	PWM mode register 1 (PM1)						PM13					PM10	?	?	?	?	0	?	?	?	0
209 ₁₆	PWM mode register 2 (PM2)	0	0	0			PM24	PM23	PM22	PM21	PM20	00 ₁₆									
20A ₁₆	ROM correction address 1 (high-order)							00 ₁₆													
20B ₁₆	ROM correction address 1 (low-order)							00 ₁₆													
20C ₁₆	ROM correction address 2 (high-order)							00 ₁₆													
20D ₁₆	ROM correction address 2 (low-order)							00 ₁₆													
20E ₁₆	ROM correction enable register (RCR)											RC1	RC0	00 ₁₆							
20F ₁₆								?													
210	Clock frequency set register (CFS)							0 0 0 0 0 1 1 1 0													
211	Clock control register 2(CC2)	0	1	0	0	0	1	0	0	00 ₁₆											
212	Clock control register 3(CC3)	CC37	0	CC35	0	0	0	0	0	00 ₁₆											

M37151M6/M8/MA/MC/MF-XXXFP, M37151EFP

SINGLE-CHIP 8-BIT CMOS MICROCOMPUTER with CLOSED CAPTION DECODER
and ON-SCREEN DISPLAY CONTROLLER

<Bit allocation>

: } Function bit
Name : }

: No function bit

0 : Fix to this bit to "0"
(do not write to "1")

1 : Fix to this bit to "1"
(do not write to "0")

<State immediately after reset>

0 : "0" immediately after reset

1 : "1" immediately after reset

? : Indeterminate immediately
after reset

Register	Bit allocation								State immediately after reset							
	b7							b0	b7							b0
Processor status register (PS)	N	V	T	B	D	I	Z	C	?	?	?	?	?	1	?	?
Program counter (PCH)									Contents of address FFFF ₁₆							
Program counter (PCL)									Contents of address FFFE ₁₆							

M37151M6/M8/MA/MC/MF-XXXFP, M37151EFFP

SINGLE-CHIP 8-BIT CMOS MICROCOMPUTER with CLOSED CAPTION DECODER
and ON-SCREEN DISPLAY CONTROLLER

Structure of Register

The figure of each register structure describes its functions, contents at reset, and attributes as follows:

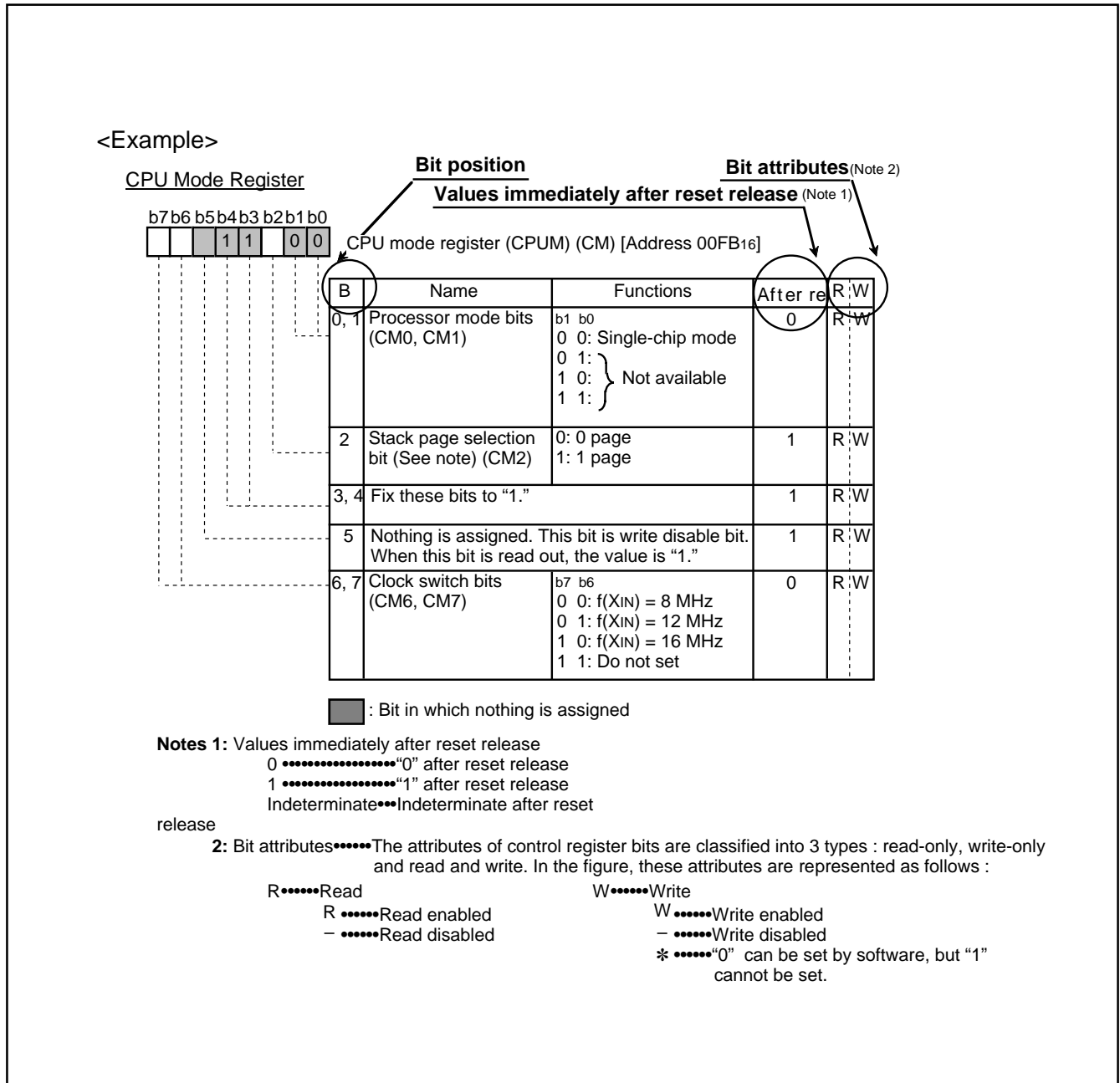

M37151M6/M8/MA/MC/MF-XXXFP, M37151EFP

SINGLE-CHIP 8-BIT CMOS MICROCOMPUTER with CLOSED CAPTION DECODER
and ON-SCREEN DISPLAY CONTROLLER

Address 00C1₁₆, 00C5₁₆

Port Pi Direction Register

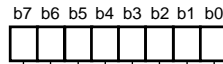

Port Pi direction register (Di) (i=0, 2) [Addresses 00C1₁₆, 00C5₁₆]

B	Name	Functions	After reset	R	W
0	Port Pi direction register	0 : Port Pi ₀ input mode 1 : Port Pi ₀ output mode	0	R	W
1		0 : Port Pi ₁ input mode 1 : Port Pi ₁ output mode	0	R	W
2		0 : Port Pi ₂ input mode 1 : Port Pi ₂ output mode	0	R	W
3		0 : Port Pi ₃ input mode 1 : Port Pi ₃ output mode	0	R	W
4		0 : Port Pi ₄ input mode 1 : Port Pi ₄ output mode	0	R	W
5		0 : Port Pi ₅ input mode 1 : Port Pi ₅ output mode	0	R	W
6		0 : Port Pi ₆ input mode 1 : Port Pi ₆ output mode	0	R	W
7		0 : Port Pi ₇ input mode 1 : Port Pi ₇ output mode	0	R	W

Address 00C2₁₆

Port P1 register

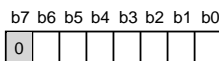

Port P1 register (P1) [Address 00C2₁₆]

B	Name	Functions	After reset	R	W
0	Port P1 register	Port P1 ₀ data	Indeterminate	R	W
1		Port P1 ₁ data	Indeterminate	R	W
2		Port P1 ₂ data	Indeterminate	R	W
3		Port P1 ₃ data	Indeterminate	R	W
4		Port P1 ₄ data	Indeterminate	R	W
5		Port P1 ₅ data	0	R	W
6	Port P1 ₆ data	Indeterminate	Indeterminate	R	W
7	Fix this bit to "0"		Indeterminate	R	W

M37151M6/M8/MA/MC/MF-XXXFP, M37151EFP

SINGLE-CHIP 8-BIT CMOS MICROCOMPUTER with CLOSED CAPTION DECODER
and ON-SCREEN DISPLAY CONTROLLER

Address 00C316

Port P1 direction register

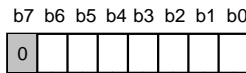

Port P1 direction register (D1) [Address 00C316]

B	Name	Functions	After reset	R	W
0	Port P1 direction register	0 : Port P1 ₀ input mode (note) 1 : Port P1 ₀ output mode	1	R	W
1		0 : Port P1 ₁ input mode 1 : Port P1 ₁ output mode	0	R	W
2		0 : Port P1 ₂ input mode 1 : Port P1 ₂ output mode	0	R	W
3		0 : Port P1 ₃ input mode 1 : Port P1 ₃ output mode	0	R	W
4		0 : Port P1 ₄ input mode 1 : Port P1 ₄ output mode	0	R	W
5		0 : Port P1 ₅ input mode 1 : Port P1 ₅ output mode	1	R	W
6		0 : Port P1 ₆ input mode 1 : Port P1 ₆ output mode	0	R	W
7	Fix this bit to "0"		0	R	W

Note: When using P10 as a general-purpose port, set the Clock Control Register 3 (address 021216) bit 7 to 1. When using P10 as a clock control signal, refer to 8.14.1 oscillation control. P10 becomes clock control signal output and "H" output setting immediately after reset release, and P16 becomes "L" output setting after reset release.

Address 00C616

Port P3 register

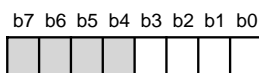

Port P3 register (P3) [Address 00C616]

B	Name	Functions	After reset	R	W
0	Port P3 register	Port P3 ₀ data	Indeterminate	R	W
1		Port P3 ₁ data	Indeterminate	R	W
2	Switch bit of I ² C-BUS interface and port P3 (BSEL20) (See note)	0: Port P3 ₀ , Port P3 ₁ 1: I ² CBUS (SDA3,SCL3)	0	R	W
3	SCL3/P3 ₁ -SCL1/P1 ₁ SDA3/P3 ₀ -SDA1/P1 ₃ Connection control bit (BSEL21)	0: Cutting 1: Connection	0	R	W
4 to 7	Nothing is assigned. This bit is write disable bit. When this bit is read out, the value is "0."		0	R	-

Notes • For the ports used as the Multi-master I²C-BUS interface, set their direction registers to 1.
• To use SCL3 and SDA3, set the I²C Control Register (address 00F916) bits 6–7 to 0.

M37151M6/M8/MA/MC/MF-XXXFP, M37151EFP

SINGLE-CHIP 8-BIT CMOS MICROCOMPUTER with CLOSED CAPTION DECODER
and ON-SCREEN DISPLAY CONTROLLER

Address 00C7₁₆

Port P3 direction register

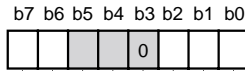

Port P3 direction register (D3) [Address 00C7₁₆]

B	Name	Functions	After reset	R	W
0	Port P3 direction register (See note 1)	0 : Port P3 ₀ input 1 : Port P3 ₀ output	0	R	W
1		0 : Port P3 ₁ input 1 : Port P3 ₁ output	0	R	W
2	Output amplitude level selection bit (OUTS) (See note 2)	0 : 2 value output 1 : 3 value output	0	R	W
3	Fix this bit to "0."		0	R	W
4,5	Nothing is assigned fix these bits When this bit are read out, the value are "0."		0	R	-
6	Timer 3 (T3SC)	Refer to explanation of a timer	0	R	W
7	Timer 2 (T2SC)	0 : P2 ₄ input 1 : P1 ₆ input	0	R	W

- Notes 1:** When using the port as the I²C-BUS interface, set the Port P3 Direction Register to 1.
2: Use the Clock Control Register 3 (address 0212₁₆) bit 5 to select the binary output level of OUT.

Address 00CA₁₆

Port P5 register

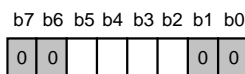

Port P5 register (P5) [Address 00CA₁₆]

B	Name	Functions	After reset	R	W
0, 1	Fix these bits to "0."		Indeterminate	R	W
2	Port P5 register	Port P5 ₂ data	Indeterminate	R	W
3		Port P5 ₃ data	Indeterminate	R	W
4		Port P5 ₄ data	Indeterminate	R	W
5		Port P5 ₅ data	Indeterminate	R	W
6	Fix these bits to "0."		Indeterminate	-	W
7			Indeterminate	R	W

M37151M6/M8/MA/MC/MF-XXXFP, M37151EFFP

SINGLE-CHIP 8-BIT CMOS MICROCOMPUTER with CLOSED CAPTION DECODER
and ON-SCREEN DISPLAY CONTROLLER

Address 00CB₁₆

OSD Port Control Register

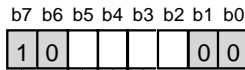

OSD port control register (PF) [Address 00CB₁₆]

B	Name	Functions	After reset	R	W
0, 1	Fix these bits to "0."		0	R	—
2	Port P5 ₂ output signal selection bit (PF2)	0 : B signal output 1 : Port P5 ₂ output	0	R	W
3	Port P5 ₃ output signal selection bit (PF3)	0 : G signal output 1 : Port P5 ₃ output	0	R	W
4	Port P5 ₄ output signal selection bit (PF4)	0 : R signal output 1 : Port P5 ₄ output	0	R	W
5	Port P5 ₅ output signal selection bit (PF5)	0 : OUT signal output 1 : Port P5 ₅ output	0	R	W
6	Fix this bit to "0."		Indeterminate	—	W
7	Fix this bit to "1."		0	R	W

Address 00CC₁₆

Timer return setting register

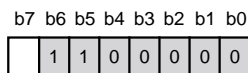

Timer return setting register (TMS) [Address 00CC₁₆]

B	Name	Functions	After reset	R	W
0 to 4	Fix these bits to "0."		0	R	W
5, 6	Fix these bits to "1."		0	R	W
7	STOP mode return selection bit (TMS)	0 : Timer Count "07FF ₁₆ " 1 : Timer Count Variable	0	R	W

M37151M6/M8/MA/MC/MF-XXXFP, M37151EFP

SINGLE-CHIP 8-BIT CMOS MICROCOMPUTER with CLOSED CAPTION DECODER
and ON-SCREEN DISPLAY CONTROLLER

Address 00CD₁₆

Clock control register 1

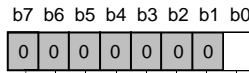

Clock control register 1 (CC1) [Address 00CD₁₆]

B	Name	Functions	After reset	R	W
0	System clock generating circuit control bit (CC10)	0: Operation 1: Stop	0	R	W
1 to 7	Fix these bits to "0"		0	R	W

Address 00D0₁₆

OSD Control Register

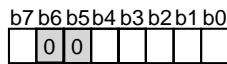

OSD control register (OC) [Address 00D0₁₆]

B	Name	Functions	After reset	R	W
0	OSD control bit (OC0) (See note 1)	0 : All-blocks display off 1 : All-blocks display on	0	R	W
1	Automatic solid space control bit (OC1)	0 : OFF 1 : ON	0	R	W
2	Window control bit (OC2)	0 : OFF 1 : ON	0	R	W
3	CC mode clock selection bit (OC3)	0 : Data slicer clock 1 : Internal oscillating clock f(osc)	0	R	W
4	OSD mode clock selection bit (OC4)	0 : Data slicer clock 1 : Internal oscillating clock f(osc)	0	R	W
5, 6	Fix these bits to "0."		0	R	W
7	Pre-divide ratio selection bit (OC7) (See note 2)	0 : Divide ratio by the block control register 1 : Pre-divide ratios = X 1 for blocks 1 and 2	0	R	W

- Notes 1:** Even this bit is switched during display, the display screen remains unchanged until a rising (falling) of the next Vsync
- 2:** This bit's priority is higher than BCi4 of Block Control Register i setting.

M37151M6/M8/MA/MC/MF-XXXFP, M37151EFFP

SINGLE-CHIP 8-BIT CMOS MICROCOMPUTER with CLOSED CAPTION DECODER
and ON-SCREEN DISPLAY CONTROLLER

Address 00D1₁₆

Horizontal Position Register

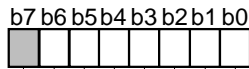

Horizontal position register (HP) [Address 00D1₁₆]

B	Name	Functions	After reset	R	W
0 to 6	Horizontal display start position control bits (HP0 to HP6)	Horizontal display start position $4T_{osc} \times n$ (n: setting value, T _{osc} : OSD oscillation cycle)	0	R	W
7	Nothing is assigned. This bit is a write disable bit. When this bit is read out, the value is "0."		0	R	—

Note: The setting value synchronizes with the V SYNC.

Address 00D2₁₆, 00D3₁₆

Block Control register i

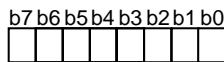

Block control register i (BCi) (i=1, 2) [Addresses 00D2₁₆ and 00D3₁₆]

B	Name	Functions	After reset	R	W																							
0, 1	Display mode selection bits (BCi0, BCi1) (See note 1)	b1 b0 0 0: Display OFF 0 1: CC mode 1 0: OSD mode (Border OFF) 1 1: OSD mode (Border ON)	Indeterminate	R	W																							
2, 3	Dot size selection bits (BCi2, BCi3)	<table border="1"> <thead> <tr> <th>b4</th> <th>b3</th> <th>b2</th> <th>Pre-divide Ratio</th> <th>Dot Size</th> </tr> </thead> <tbody> <tr> <td>0</td> <td>0</td> <td>0</td> <td rowspan="3">× 2</td> <td>1T_c × 1/2H</td> </tr> <tr> <td>0</td> <td>1</td> <td>1</td> <td>1T_c × 1H</td> </tr> <tr> <td>1</td> <td>0</td> <td>0</td> <td>2T_c × 2H</td> </tr> <tr> <td></td> <td></td> <td>1</td> <td>1</td> <td>3T_c × 3H</td> </tr> </tbody> </table>	b4	b3	b2	Pre-divide Ratio	Dot Size	0	0	0	× 2	1T _c × 1/2H	0	1	1	1T _c × 1H	1	0	0	2T _c × 2H			1	1	3T _c × 3H	Indeterminate	R	W
b4	b3	b2	Pre-divide Ratio	Dot Size																								
0	0	0	× 2	1T _c × 1/2H																								
0	1	1		1T _c × 1H																								
1	0	0		2T _c × 2H																								
		1	1	3T _c × 3H																								
4	Pre-divide ratio selection bit (BCi4)	<table border="1"> <thead> <tr> <th>b4</th> <th>b3</th> <th>b2</th> <th>Pre-divide Ratio</th> <th>Dot Size</th> </tr> </thead> <tbody> <tr> <td>1</td> <td>0</td> <td>0</td> <td rowspan="4">× 3</td> <td>1T_c × 1/2H</td> </tr> <tr> <td>1</td> <td>0</td> <td>1</td> <td>1T_c × 1H</td> </tr> <tr> <td>1</td> <td>1</td> <td>0</td> <td>2T_c × 2H</td> </tr> <tr> <td>1</td> <td>1</td> <td>1</td> <td>3T_c × 3H</td> </tr> </tbody> </table>	b4	b3	b2	Pre-divide Ratio	Dot Size	1	0	0	× 3	1T _c × 1/2H	1	0	1	1T _c × 1H	1	1	0	2T _c × 2H	1	1	1	3T _c × 3H	Indeterminate	R	W	
b4	b3	b2	Pre-divide Ratio	Dot Size																								
1	0	0	× 3	1T _c × 1/2H																								
1	0	1		1T _c × 1H																								
1	1	0		2T _c × 2H																								
1	1	1		3T _c × 3H																								
5	OUT output control bit (BCi5)	0: 2 value output control 1: 3 value output control (notes 3)	Indeterminate	R	W																							
6	Vertical display start position control bit (BCi6)	BC16: Block 1 BC26: Block 1	Indeterminate	R	W																							
7	Window top/bottom boundary control bit (BCi7)	BC17: Window top boundary BC27: Window bottom boundary	Indeterminate	R	W																							

Notes 1: T_c is OSD clock cycle divided in pre-divide circuit.

2: H is HSYNC.

3: Refer to the corresponding figure 8.11.18.

M37151M6/M8/MA/MC/MF-XXXFP, M37151EFP

SINGLE-CHIP 8-BIT CMOS MICROCOMPUTER with CLOSED CAPTION DECODER
and ON-SCREEN DISPLAY CONTROLLER

Address 00D4₁₆, 00D5₁₆

Vertical Position Register i

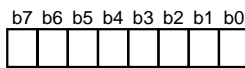

Vertical position register i (VPi) (i = 1 and 2) [Addresses 00D4₁₆, 00D5₁₆]

B	Name	Functions	After reset	R	W
0 to 7	Vertical display start position control bits (VPi0 to VPi7) (See note)	Vertical display start position = $T_H 5 (BCi6 \times 16^2 + n)$ (n: setting value, T_H : Hsync cycle, BCi6: bit 6 of block control register i)	Indeterminate	R	W

Notes 1: Set values except "00₁₆" to VPi when BCi6 is "0."
2: When OS21 of OSD control register 2 = "0", $T_H = 1H_{sync}$, and OS21 of OSD control register 2 = "1", $T_H = 2H_{sync}$.

Address 00D6₁₆

Window Register 1

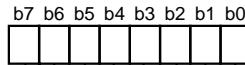

Window register 1 (WN1) [Address 00D6₁₆]

B	Name	Functions	After reset	R	W
0 to 7	Window top boundary control bits (WN10 to WN17)	Window top border position = $T_H 5 (BC17 \times 16^2 + n)$ (n: setting value, T_H : Hsync cycle, BC17: bit 7 of block control register 1)	Indeterminate	R	W

Notes 1: Set values except "00₁₆" to WN1 when BC17 is "0."
2: Set values fit for the following condition: $WN1 < WN2$.
3: When OC21 of OSD control register 2 is "0", T_H is 1 Hsync. And when "1", T_H is 2 Hsync.

Address 00D7₁₆

Window Register 2

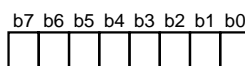

Window register 2 (WN2) [Address 00D7₁₆]

B	Name	Functions	After reset	R	W
0 to 7	Window bottom boundary control bits (WN20 to WN27)	Window bottom border position = $T_H 5 (BC27 \times 16^2 + n)$ (n: setting value, T_H : Hsync cycle, BC27: bit 7 of block control register 2)	Indeterminate	R	W

Notes 1: Set values fit for the following condition: $WN1 < WN2$.
2: When OC21 of OSD control register 2 is "0", T_H is 1 Hsync. And when "1", T_H is 2 Hsync.

M37151M6/M8/MA/MC/MF-XXXFP, M37151EFFP

SINGLE-CHIP 8-BIT CMOS MICROCOMPUTER with CLOSED CAPTION DECODER
and ON-SCREEN DISPLAY CONTROLLER

Address 00D8₁₆

I/O Polarity Control Register

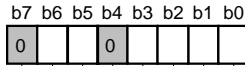

I/O polarity control register (PC) [Address 00D8₁₆]

B	Name	Functions	After reset	R	W
0	H _{SYNC} input polarity switch bit (PC0)	0 : Positive polarity input 1 : Negative polarity input	0	R	W
1	V _{SYNC} input polarity switch bit (PC1)	0 : Positive polarity input 1 : Negative polarity input	0	R	W
2	R, G, B output polarity switch bit (PC2)	0 : Positive polarity output 1 : Negative polarity output	0	R	W
3	OUT1 output polarity switch bit (PC3)	0 : Positive polarity output 1 : Negative polarity output	0	R	W
5	Display dot line selection bit (PC5) (See note)	0 : "□" at even field "■" at odd field 1 : "■" at even field "□" at odd field	0	R	W
6	Field determination flag (PC6)	0 : Even field 1 : Odd field	1	R	—
4, 7	Fix these bits to "0."		0	R	W

Note: Refer to the corresponding figure. 8.11.15

Address 00D9₁₆

Raster Color Register

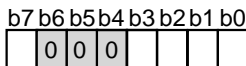

Raster color register (RC) [Address 00D9₁₆]

B	Name	Functions	After reset	R	W
0	Raster color R control bit (RC0)	0 : No output 1 : Output	0	R	W
1	Raster color G control bit (RC1)	0 : No output 1 : Output	0	R	W
2	Raster color B control bit (RC2)	0 : No output 1 : Output	0	R	W
3	Raster color OUT control bit (RC3)	0 : No output 1 : Output	0	R	W
4 to 6	Fix these bits to "0."		0	R	W
7	Port function selection bit (RC7)	0 : XCIN, XCOUT 1 : P26, P27	0	R	W

M37151M6/M8/MA/MC/MF-XXXFP, M37151EFP

SINGLE-CHIP 8-BIT CMOS MICROCOMPUTER with CLOSED CAPTION DECODER
and ON-SCREEN DISPLAY CONTROLLER

Address 00DB₁₆

OSD Control Register 2

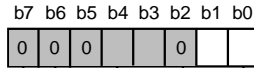

OSD control register (OC2) [Address 00DB₁₆]

B	Name	Functions	After reset	R	W
0	Vertical character dot size (OC20)	0: 1H _{SYNC} (normal scan) 1: 2H _{SYNC} (by scan)	0	R	W
1	Vertical start position count selection bit (OC21)	0: Counts one time by 1H _{SYNC} .(normal scan) 1: Counts two time by 1H _{SYNC} .(by scan)	0	R	W
2	Fix this bit to "0."		0	R	W
3	Nothing is assigned. This bit is write disable bit. When this bit is read out, the value is "0."		0	R	—
4	Nothing is assigned. This bit is write disable bit. When this bit is read out, the value is "0."		Indeterminate	—	—
5 to 7	Fix these bits to "0."		0	R	W

Address 00DC₁₆

Interrupt Input Polarity Register

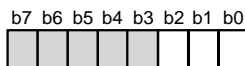

Interrupt input polarity register (RE) [Address 00DC₁₆]

B	Name	Functions	After reset	R	W
0	INT1 polarity switch bit (INT1)	0 : Positive polarity 1 : Negative polarity	0	R	W
1	INT2 polarity switch bit (INT2)	0 : Positive polarity 1 : Negative polarity	0	R	W
2	INT3 polarity switch bit (INT3)	0 : Positive polarity 1 : Negative polarity	0	R	W
3 to 7	Nothing is assigned. These bits are write disable bits. When these bits are read out, the values are "0."		0	R	—

M37151M6/M8/MA/MC/MF-XXXFP, M37151EFFP

SINGLE-CHIP 8-BIT CMOS MICROCOMPUTER with CLOSED CAPTION DECODER
and ON-SCREEN DISPLAY CONTROLLER

Address 00E0₁₆

Data Slicer Control Register 1

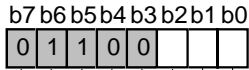

Data slicer control register 1(DSC1) [Address 00E0₁₆]

B	Name	Functions	After reset	R	W
0	Data slicer and timing signal generating circuit control bit (DSC10)	0: Stopped 1: Operating	0	R	W
1	Selection bit of data slice reference voltage generating field (DSC11)	0: F2 1: F1	0	R	W
2	Reference clock source selection bit (DSC12)	0: Video signal 1: HSYNC signal	0	R	W
3, 4	Fix these bits to "0."		0	R	W
5, 6	Fix these bits to "1."		0	R	W
7	Fix this bit to "0."		0	R	W

Definition of fields 1 (F1) and 2 (F2)



M37151M6/M8/MA/MC/MF-XXXFP, M37151EFP

SINGLE-CHIP 8-BIT CMOS MICROCOMPUTER with CLOSED CAPTION DECODER
and ON-SCREEN DISPLAY CONTROLLER

Data Slicer Control Register 2

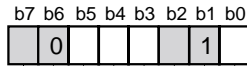

Data slicer control register 2 (DSC2) [Address 00E1₁₆]

B	Name	Functions	After reset	R	W
1	Caption data latch completion flag 1 (DSC20)	0: Data is not latched yet and a clock-run-in is not determined. 1: Data is latched and a clock-run-in is determined.	Indeterminate	R	—
1	Fix this bit to "1."		0	R	W
2	Test bit	Read-only	Indeterminate	R	—
0	Field determination flag(DSC23)	0: F2 1: F1	Indeterminate	R	—
4	Vertical synchronous signal (V _{sep}) generating method selection bit (DSC24)	0: Method (1) 1: Method (2)	0	R	W
5	V-pulse shape determination flag (DSC25)	0: Match 1: Mismatch	Indeterminate	R	—
6	Fix this bit to "0."		0	R	W
7	Test bit	Read-only	Indeterminate	R	—

Definition of fields 1 (F1) and 2 (F2)



Clock Run-in Detect Register

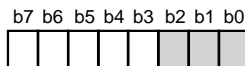

Clock run-in detect register (CRD) [Address 00E4₁₆]

B	Name	Functions	After reset	R	W
0 to 2	Test bits	Read-only	0	R	—
3 to 7	Clock run-in detection bit(CRD3 to CRD7)	Number of reference clocks to be counted in one clock run-in pulse period.	0	R	—

M37151M6/M8/MA/MC/MF-XXXFP, M37151EFFP

SINGLE-CHIP 8-BIT CMOS MICROCOMPUTER with CLOSED CAPTION DECODER
and ON-SCREEN DISPLAY CONTROLLER

Data Clock Position Register

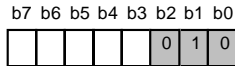

Data clock position register (DPS) [Address 00E5₁₆]

B	Name	Functions	After reset	R	W
0	Fix this bit to "0."		1	R	W
1	Fix this bit to "1."		0	R	W
2	Fix this bit to "0."		0	R	W
3	Data clock position set bits (DPS3 to DPS7)		1	R	W
4 to 7			0		

Caption Position Register

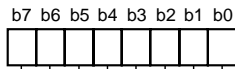

Caption Position Register (CPS) [Address 00E6₁₆]

B	Name	Functions	After reset	R	W
0 to 4	Caption position bits(CPS0 to CPS4)		0	R	W
5	Caption data latch completion flag 2 (CPS5)	0: Data is not latched yet and a clock-run-in is not determined. 1: Data is latched and a clock-run-in is determined.	Indeterminate	R	—
6, 7	Slice line mode specification bits (in 1 field) (CPS6, CPS7)	Refer to the corresponding Table (Table 8.10.1).	0	R	W

Address 00E9₁₆

Sync Pulse Counter Register

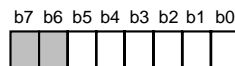

Sync pulse counter register (HC) [Address 00E9₁₆]

B	Name	Functions	After reset	R	W
0 to 4	Count value (HC0 to HC4)		0	R	—
5	Count source (HC5)	0: Hsync signal 1: Composite sync signal	0	R	W
6, 7	Nothing is assigned. These bits are write disable bits. When these bits are read out, the values are "0."		0	R	—

M37151M6/M8/MA/MC/MF-XXXFP, M37151EFP

SINGLE-CHIP 8-BIT CMOS MICROCOMPUTER with CLOSED CAPTION DECODER
and ON-SCREEN DISPLAY CONTROLLER

Address 00EB16

Serial I/O Mode Register

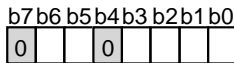

Serial I/O mode register (SM) [Address 00EB16]

B	Name	Functions	After reset	R	W
0, 1	Internal synchronous clock selection bits (SM0, SM1)	b1 b0 0 0: f(XIN)/8 or f(XCIN)/8 0 1: f(XIN)/16 or f(XCIN)/16 1 0: f(XIN)/32 or f(XCIN)/32 1 1: f(XIN)/64 or f(XCIN)/64	0	R	W
2	Synchronous clock selection bit (SM2)	0: External clock 1: Internal clock	0	R	W
3	Port function selection bit (SM3)	0: P20, P21 1: SCLK, SOUT	0	R	W
4	Fix this bit to "0."		0	R	W
5	Transfer direction selection bit (SM5)	0: LSB first 1: MSB first	0	R	W
6	Transfer clock input pin selection bit (SM6)	0: Input signal from SIN pin 1: Input signal from SOUT pin	0	R	W
7	Fix this bit to "0."		0	R	W

Address 00EC16

A-D Control Register 1

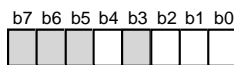

A-D control register 1 (AD1) [Address 00EC16]

B	Name	Functions	After reset	R	W
0 to 2	Analog input pin selection bits (ADC10 to ADC12)	b2 b1 b0 0 0 0: AD1 0 0 1: AD2 0 1 0: AD3 0 1 1: AD4 1 0 0: AD5 1 0 1: AD6 1 1 0: AD7 1 1 1: AD8	0	R	W
3	This bit is a write disable bit. When this bit is read out, the value is "0."		0	R	—
4	Storage bit of comparison result (ADC14)	0: Input voltage < reference voltage 1: Input voltage > reference voltage	Indeterminate	R	—
5 to 7	Nothing is assigned. These bits are write disable bits. When these bits are read out, the values are "0."		0	R	—

M37151M6/M8/MA/MC/MF-XXXFP, M37151EFP

SINGLE-CHIP 8-BIT CMOS MICROCOMPUTER with CLOSED CAPTION DECODER
and ON-SCREEN DISPLAY CONTROLLER

Address 00F5₁₆

Timer Mode Register 2

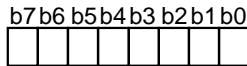

Timer mode register 2 (TM2) [Address 00F5₁₆]

B	Name	Functions	After reset	R	W
0	Timer 3 count source selection bit (TM20)	(b6 at address 00C7 ₁₆) ↓ b0 0 0 : f(X _{IN})/16 or f(X _{CIN})/16 (See note) 1 0 : f(X _{CIN}) 0 1 : } External clock from TIM3 pin 1 1 : }	0	R	W
1, 4	Timer 4 count source selection bits (TM21, TM24)	b4 b1 0 0 : Timer 3 overflow signal 0 1 : f(X _{IN})/16 or f(X _{CIN})/16 (See note) 1 0 : f(X _{IN})/2 or f(X _{CIN})/2 (See note) 1 1 : f(X _{CIN})	0	R	W
2	Timer 3 count stop bit (TM22)	0: Count start 1: Count stop	0	R	W
3	Timer 4 count stop bit (TM23)	0: Count start 1: Count stop	0	R	W
5	Timer 5 count stop bit (TM25)	0: Count start 1: Count stop	0	R	W
6	Timer 6 count stop bit (TM26)	0: Count start 1: Count stop	0	R	W
7	Timer 5 count source selection bit 1 (TM27)	0: f(X _{IN})/16 or f(X _{CIN})/16 (See note) 1: Count source selected by bit 6 of TM1	0	R	W

Note: Either f(X_{IN}) or f(X_{CIN}) is selected by bit 7 of the CPU mode register.

Address 00F6₁₆

I²C Data Shift Register

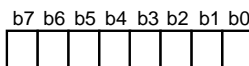

I²C data shift register 1 (S0) [Address 00F6₁₆]

B	Name	Functions	After reset	R	W
0 to 7	D0 to D7	This is an 8-bit shift register to store receive data and write transmit data.	Indeterminate	R	W

Note : To write data into the I²C data shift register after setting the MST bit to "0" (slave mode), keep an interval of 8 machine cycles or more.

M37151M6/M8/MA/MC/MF-XXXFP, M37151EFFP

SINGLE-CHIP 8-BIT CMOS MICROCOMPUTER with CLOSED CAPTION DECODER
and ON-SCREEN DISPLAY CONTROLLER

Address 00F7₁₆

I²C Address Register

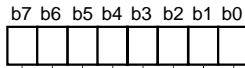

I²C address register (S0D) [Address 00F7₁₆]

B	Name	Functions	After reset	R	W
0	Read/write bit (RBW)	<Only in 10-bit addressing (in slave) mode> The last significant bit of address data is compared. 0: Wait the first byte of slave address after START condition (read state) 1: Wait the first byte of slave address after RESTART condition (write state)	0	R	—
1 to 7	Slave address (SAD0 to SAD6)	<In both modes> The address data is compared.	0	R	W

Address 00F8₁₆

I²C Status Register

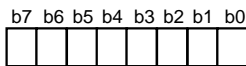

I²C status register (S1) [Address 00F8₁₆]

B	Name	Functions	After reset	R	W
0	Last receive bit (LRB) (See note)	0 : Last bit = "0" 1 : Last bit = "1" (See note)	Indeterminate	R	—
1	General call detecting flag (AD0) (See note)	0 : No general call detected 1 : General call detected (See note)	0	R	—
2	Slave address comparison flag (AAS) (See note)	0 : Address mismatch 1 : Address match (See note)	0	R	—
3	Arbitration lost detecting flag (AL) (See note)	0 : Not detected 1 : Detected (See note)	0	R	—
4	I ² C-BUS interface interrupt request bit (PIN)	0 : Interrupt request issued 1 : No interrupt request issued	1	R	W
5	Bus busy flag (BB)	0 : Bus free 1 : Bus busy	0	R	W
6, 7	Communication mode specification bits (TRX, MST)	b7 b6 0 0 : Slave receive mode 0 1 : Slave transmit mode 1 0 : Master receive mode 1 1 : Master transmit mode	0	R	W

Note : These bits and flags can be read out, but cannot be written.

M37151M6/M8/MA/MC/MF-XXXFP, M37151EFP

SINGLE-CHIP 8-BIT CMOS MICROCOMPUTER with CLOSED CAPTION DECODER
and ON-SCREEN DISPLAY CONTROLLER

Address 00F9₁₆

I²C Control Register

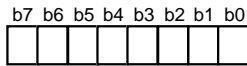

I²C control register (S1D) [Address 00F9₁₆]

B	Name	Functions	After reset	R	W
0 to 2	Bit counter (Number of transmit/recieve bits) (BC0 to BC2)	b2 b1 b0 0 0 0 : 8 0 0 1 : 7 0 1 0 : 6 0 1 1 : 5 1 0 0 : 4 1 0 1 : 3 1 1 0 : 2 1 1 1 : 1	0	R	W
3	I ² C-BUS interface use enable bit (ESO)	0 : Disabled 1 : Enabled	0	R	W
4	Data format selection bit(ALS)	0 : Addressing mode 1 : Free data format	0	R	W
5	Addressing format selection bit (10BIT SAD)	0 : 7-bit addressing format 1 : 10-bit addressing format	0	R	W
6, 7	Connection control bits between I ² C-BUS interface and ports (BSEL0, BSEL1)	b7 b6 Connection port (See note) 0 0: None 0 1: SCL1, SDA1 1 0: SCL2, SDA2 1 1: SCL1, SDA1 SCL2, SDA2	0	R	W

Note:

- Set the corresponding direction register to "1" to use the port as multi-master I²C-BUS interface.
- To use SCL1, SDA1, SCL2 and SDA2, set the port P3 Register (address 00C6₁₆) bit 2 to 0.

M37151M6/M8/MA/MC/MF-XXXFP, M37151EFFP

SINGLE-CHIP 8-BIT CMOS MICROCOMPUTER with CLOSED CAPTION DECODER
and ON-SCREEN DISPLAY CONTROLLER

Address 00FA₁₆

I²C Clock Control Register

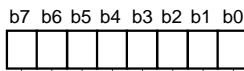

I²C clock control register (S2) [Address 00FA₁₆]

B	Name	Functions	After reset	R	W		
0 to 4	SCL frequency control bits (CCR0 to CCR4)	Setup value of CCR4–CCR0	Standard clock mode	0	R	W	
		00 to 02	Setup disabled				Setup disabled
		03	Setup disabled				333
		04	Setup disabled				250
		05	100				400 (See note)
		06	83.3				166
		:	500/CCR value				1000/CCR value
		1D	17.2				34.5
		1E	16.6				33.3
		1F	16.1				32.3
(φ = 4 MHz, unit : kHz)							
5	SCL mode specification bit (FAST MODE)	0: Standard clock mode 1: High-speed clock mode	0	R	W		
6	ACK bit (ACK BIT)	0: ACK is returned. 1: ACK is not returned.	0	R	W		
7	ACK clock bit (ACK)	0: No ACK clock 1: ACK clock	0	R	W		

Note. At 400kHz in the high-speed clock mode, the duty is as below.
 "0" period : "1" period = 3 : 2
 In the other cases, the duty is as below.
 "0" period : "1" period = 1 : 1

M37151M6/M8/MA/MC/MF-XXXFP, M37151EFP

SINGLE-CHIP 8-BIT CMOS MICROCOMPUTER with CLOSED CAPTION DECODER
and ON-SCREEN DISPLAY CONTROLLER

Address 00FB₁₆

CPU Mode Register

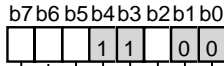

CPU mode register (CM) [Address 00FB₁₆]

B	Name	Functions	After reset	R	W
0, 1	Processor mode bits (CM0, CM1)	b1 b0 0 0: Single-chip mode 0 1: } 1 0: } Not available 1 1: }	0	R	W
2	Stack page selection bit (CM2) (See note)	0: 0 page 1: 1 page	1	R	W
3, 4	Fix these bits to "1."		1	R	W
5	XcOUT drivability selection bit (CM5)	0: LOW drive 1: HIGH drive	1	R	W
6	Main Clock (X _{IN} -X _{OUT}) stop bit (CM6)	0: Oscillating 1: Stopped	0	R	W
7	Internal system clock selection bit (CM7)	0: X _{IN} selected (high-speed mode) 1: X _{CIN} -X _{COUT} selected (low-speed mode)	0	R	W

Note. This bit is set to "1" after the reset release.

Address 00FC₁₆

Interrupt Request Register 1

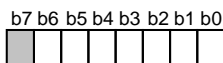

Interrupt request register 1 (IREQ1) [Address 00FC₁₆]

B	Name	Functions	After reset	R	W
0	Timer 1 interrupt request bit (TM1R)	0 : No interrupt request issued 1 : Interrupt request issued	0	R	*
1	Timer 2 interrupt request bit (TM2R)	0 : No interrupt request issued 1 : Interrupt request issued	0	R	*
2	Timer 3 interrupt request bit (TM3R)	0 : No interrupt request issued 1 : Interrupt request issued	0	R	*
3	Timer 4 interrupt request bit (TM4R)	0 : No interrupt request issued 1 : Interrupt request issued	0	R	*
4	OSD interrupt request bit (OSDR)	0 : No interrupt request issued 1 : Interrupt request issued	0	R	*
5	VSYNC interrupt request bit (VSCR)	0 : No interrupt request issued 1 : Interrupt request issued	0	R	*
6	INT3 external interrupt request bit (IN3R)	0 : No interrupt request issued 1 : Interrupt request issued	0	R	*
7	Nothing is assigned. This bit is a write disable bit. When this bit is read out, the value is "0."		0	R	—

*: "0" can be set by software, but "1" cannot be set.

M37151M6/M8/MA/MC/MF-XXXFP, M37151EFFP

SINGLE-CHIP 8-BIT CMOS MICROCOMPUTER with CLOSED CAPTION DECODER
and ON-SCREEN DISPLAY CONTROLLER

Address 00FD₁₆

Interrupt Request Register 2

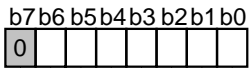

Interrupt request register 2 (IREQ2) [Address 00FD₁₆]

B	Name	Functions	After reset	R	W
0	INT1 external interrupt request bit (IN1R)	0 : No interrupt request issued 1 : Interrupt request issued	0	R	*
1	Data slicer interrupt request bit (DSR)	0 : No interrupt request issued 1 : Interrupt request issued	0	R	*
2	Serial I/O interrupt request bit (SIR)	0 : No interrupt request issued 1 : Interrupt request issued	0	R	*
3	f(XIN)/4096 interrupt request bit (CKR)	0 : No interrupt request issued 1 : Interrupt request issued	0	R	*
4	INT2 external interrupt request bit (IN2R)	0 : No interrupt request issued 1 : Interrupt request issued	0	R	*
5	Multi-master I ² C-BUS interrupt request bit (IICR)	0 : No interrupt request issued 1 : Interrupt request issued	0	R	*
6	Timer 5 • 6 interrupt request bit (TM56R)	0 : No interrupt request issued 1 : Interrupt request issued	0	R	*
7	Fix this bit to "0."		0	R	W

*: "0" can be set by software, but "1" cannot be set.

Address 00FE₁₆

Interrupt Control Register 1

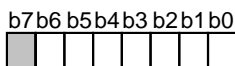

Interrupt control register 1 (ICON1) [Address 00FE₁₆]

B	Name	Functions	After reset	R	W
0	Timer 1 interrupt enable bit (TM1E)	0 : Interrupt disabled 1 : Interrupt enabled	0	R	W
1	Timer 2 interrupt enable bit (TM2E)	0 : Interrupt disabled 1 : Interrupt enabled	0	R	W
2	Timer 3 interrupt enable bit (TM3E)	0 : Interrupt disabled 1 : Interrupt enabled	0	R	W
3	Timer 4 interrupt enable bit (TM4E)	0 : Interrupt disabled 1 : Interrupt enabled	0	R	W
4	OSD interrupt enable bit (OSDE)	0 : Interrupt disabled 1 : Interrupt enabled	0	R	W
5	VSYNC interrupt enable bit (VSCE)	0 : Interrupt disabled 1 : Interrupt enabled	0	R	W
6	INT3 external interrupt enable bit (IN3E)	0 : Interrupt disabled 1 : Interrupt enabled	0	R	W
7	Nothing is assigned. This bit is a write disable bit. When this bit is read out, the value is "0."		0	R	—

M37151M6/M8/MA/MC/MF-XXXFP, M37151EFP

SINGLE-CHIP 8-BIT CMOS MICROCOMPUTER with CLOSED CAPTION DECODER
and ON-SCREEN DISPLAY CONTROLLER

Address 00FF₁₆

Interrupt Control Register 2

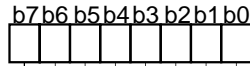

Interrupt control register 2 (ICON2) [Address 00FF₁₆]

B	Name	Functions	After reset	R	W
0	INT1 external interrupt enable bit (IN1E)	0 : Interrupt disabled 1 : Interrupt enabled	0	R	W
1	Data slicer interrupt enable bit (DSE)	0 : Interrupt disabled 1 : Interrupt enabled	0	R	W
2	Serial I/O interrupt enable bit (SIE)	0 : Interrupt disabled 1 : Interrupt enabled	0	R	W
3	f(XIN)/4096 interrupt enable bit (CKE)	0 : Interrupt disabled 1 : Interrupt enabled	0	R	W
4	INT2 external interrupt enable bit (IN2E)	0 : Interrupt disabled 1 : Interrupt enabled	0	R	W
5	Multi-master I ² C-BUS interface interrupt enable bit (IICE)	0 : Interrupt disabled 1 : Interrupt enabled	0	R	W
6	Timer 5 • 6 interrupt enable bit (TM56E)	0 : Interrupt disabled 1 : Interrupt enabled	0	R	W
7	Timer 5 • 6 interrupt switch bit (TM56C)	0 : Timer 5 1 : Timer 6	0	R	W

Address 0208₁₆

PWM Mode Register 1

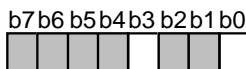

PWM mode register 1 (PM1) [Address 0208₁₆]

B	Name	Functions	After reset	R	W
0	PWM counts source selection bit (PM10)	0 : Count source supply 1 : Count source stop	0	R	W
1, 2	Nothing is assigned. These bits are write disable bits. When these bits are read out, the values are "0."		Indeterminate	R	—
3	PWM output polarity selection bit (PM13)	0 : Positive polarity 1 : Negative polarity	0	R	W
4 to 7	Nothing is assigned. These bits are write disable bits. When these bits are read out, the values are "0."		Indeterminate	R	—

M37151M6/M8/MA/MC/MF-XXXFP, M37151EFP

SINGLE-CHIP 8-BIT CMOS MICROCOMPUTER with CLOSED CAPTION DECODER
and ON-SCREEN DISPLAY CONTROLLER

Address 0209₁₆

PWM Mode Register 2

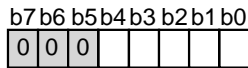

PWM mode register 2 (PM2) [Address 0209₁₆]

B	Name	Functions	After reset	R	W
0	P0 ₀ /PWM0 output selection bit (PM20)	0 : P0 ₀ output 1 : PWM0 output	0	R	W
1	P0 ₁ /PWM1 output selection bit (PM21)	0 : P0 ₁ output 1 : PWM1 output	0	R	W
2	P0 ₂ /PWM2 output selection bit (PM22)	0 : P0 ₂ output 1 : PWM2 output	0	R	W
3	P0 ₃ /PWM3 output selection bit (PM23)	0 : P0 ₃ output 1 : PWM3 output	0	R	W
4	P0 ₄ /PWM4 output selection bit (PM24)	0 : P0 ₄ output 1 : PWM4 output	0	R	W
5 to 7	Fix these bits to "0."		0	R	W

Address 020E₁₆

ROM Correction Enable Register

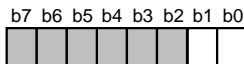

ROM correction enable register (RCR) [Address 020E₁₆]

B	Name	Functions	After reset	R	W
0	Vector 1 enable bit (RC0)	0: Disabled 1: Enabled	0	R	W
1	Vector 2 enable bit (RC1)	0: Disabled 1: Enabled	0	R	W
2 to 7	Nothing is assigned. These bits are write disable bits. When these bits are read out, the values are "0."		0	R	—

M37151M6/M8/MA/MC/MF-XXXFP, M37151EFP

SINGLE-CHIP 8-BIT CMOS MICROCOMPUTER with CLOSED CAPTION DECODER
and ON-SCREEN DISPLAY CONTROLLER

Address 0210₁₆

Clock frequency set register

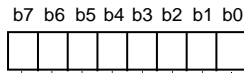

Clock frequency set register(CFS) [Address 0210₁₆]

B	Name	Functions	After reset	R	W	
0 to 7	Clock frequency bit (CFS 0 to 7)	Clock frequency (Note)		0E	R	
		Setting value(Limitation)	Frequency(MHz)			W
		0C 0D	26 28			

Note: Do not set other than the values shown above to CFS.
Then, must to use at f(X_{IN}) = 8 MHz.

Address 0211₁₆

Clock control register 2

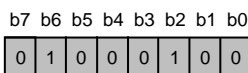

Clock control register 2 (CC2) [Address 0211₁₆]

B	Name	Functions	After reset	R	W
0,1	Fix these bits to "0"		0	R	W
2	Fix this bit to "1"		0	R	W
3 to 5	Fix these bits to "0"		0	R	W
6	Fix this bit to "1"		0	R	W
7	Fix this bit to "0"		0	R	W

M37151M6/M8/MA/MC/MF-XXXFP, M37151EFFP

SINGLE-CHIP 8-BIT CMOS MICROCOMPUTER with CLOSED CAPTION DECODER
and ON-SCREEN DISPLAY CONTROLLER

Address 0212₁₆

Clock control register 3

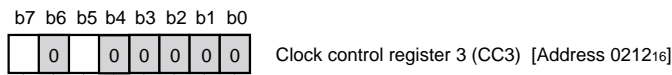

B	Name	Functions	After reset	R ; W
0 to 4	Fix these bits to "0"		0	R ; W
5	R,G,B,OUT Output amplitude level selection bit (CC35)	0: 0V-V _{cc} 1: 0V-About 0.6V _{cc}	0	R ; W
6	Fix this bit to "0"		0	R ; W
7	P1 ₀ function-selection bit (CC37)	(Note) 0: Clock control signal 1: P1 ₀ I/O	0	R ; W

Note: When used as the clock control signal, set the Port 1 Direction Register (address 00C3₁₆) bit 0 to 1.

M37151M6/M8/MA/MC/MF-XXXFP, M37151EFP

SINGLE-CHIP 8-BIT CMOS MICROCOMPUTER with CLOSED CAPTION DECODER
and ON-SCREEN DISPLAY CONTROLLER

19. PACKAGE OUTLINE

42P2R-A/E

Plastic 42pin 450mil SSOP

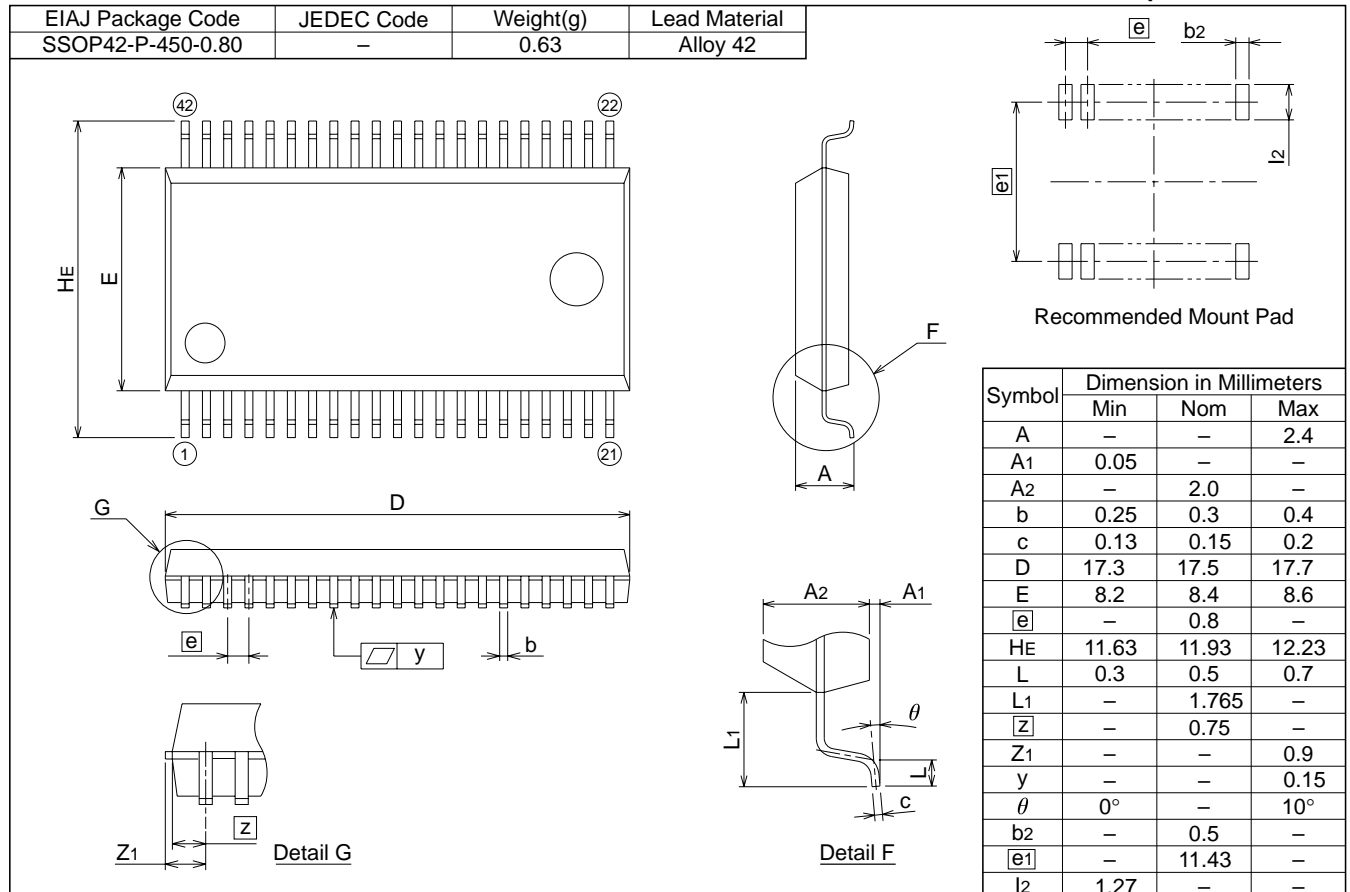

M37151M6/M8/MA/MC/MF-XXXFP, M37151EFFP

SINGLE-CHIP 8-BIT CMOS MICROCOMPUTER with CLOSED CAPTION DECODER
and ON-SCREEN DISPLAY CONTROLLER

Renesas Technology Corp.

Nippon Bldg.,6-2,Otemachi 2-chome,Chiyoda-ku,Tokyo,100-0004 Japan

Keep safety first in your circuit designs!

- Mitsubishi Electric Corporation puts the maximum effort into making semiconductor products better and more reliable, but there is always the possibility that trouble may occur with them. Trouble with semiconductors may lead to personal injury, fire or property damage. Remember to give due consideration to safety when making your circuit designs, with appropriate measures such as (i) placement of substitutive, auxiliary circuits, (ii) use of non-flammable material or (iii) prevention against any malfunction or mishap.

Notes regarding these materials

- These materials are intended as a reference to assist our customers in the selection of the Mitsubishi semiconductor product best suited to the customer's application; they do not convey any license under any intellectual property rights, or any other rights, belonging to Mitsubishi Electric Corporation or a third party.
- Mitsubishi Electric Corporation assumes no responsibility for any damage, or infringement of any third-party's rights, originating in the use of any product data, diagrams, charts, programs, algorithms, or circuit application examples contained in these materials.
- All information contained in these materials, including product data, diagrams, charts, programs and algorithms represents information on products at the time of publication of these materials, and are subject to change by Mitsubishi Electric Corporation without notice due to product improvements or other reasons. It is therefore recommended that customers contact Mitsubishi Electric Corporation or an authorized Mitsubishi Semiconductor product distributor for the latest product information before purchasing a product listed herein.
- The information described here may contain technical inaccuracies or typographical errors. Mitsubishi Electric Corporation assumes no responsibility for any damage, liability, or other loss rising from these inaccuracies or errors. Please also pay attention to information published by Mitsubishi Electric Corporation by various means, including the Mitsubishi Semiconductor home page (<http://www.mitsubishichips.com>).
- When using any or all of the information contained in these materials, including product data, diagrams, charts, programs, and algorithms, please be sure to evaluate all information as a total system before making a final decision on the applicability of the information and products. Mitsubishi Electric Corporation assumes no responsibility for any damage, liability or other loss resulting from the information contained herein.
- Mitsubishi Electric Corporation semiconductors are not designed or manufactured for use in a device or system that is used under circumstances in which human life is potentially at stake. Please contact Mitsubishi Electric Corporation or an authorized Mitsubishi Semiconductor product distributor when considering the use of a product contained herein for any specific purposes, such as apparatus or systems for transportation, vehicular, medical, aerospace, nuclear, or underwater repeater use.
- The prior written approval of Mitsubishi Electric Corporation is necessary to reprint or reproduce in whole or in part these materials.
- If these products or technologies are subject to the Japanese export control restrictions, they must be exported under a license from the Japanese government and cannot be imported into a country other than the approved destination.
- Any diversion or reexport contrary to the export control laws and regulations of Japan and/or the country of destination is prohibited.
- Please contact Mitsubishi Electric Corporation or an authorized Mitsubishi Semiconductor product distributor for further details on these materials or the products contained therein.

REVISION DESCRIPTION LIST

M37151M6/M8/MA/MC/MF-XXXFP, M37151EFP

Rev. No.	Revision Description	Rev. date
1.0	First Edition of PDF File	0212