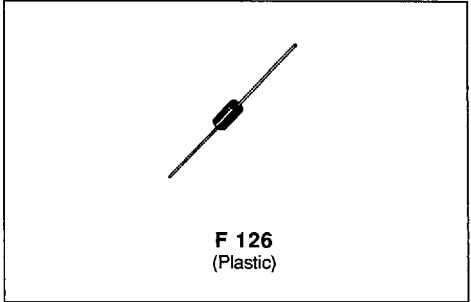

FEATURES

- BIDIRECTIONAL CROWBAR PROTECTION.
- BREAKDOWN VOLTAGE RANGE:
From 62 V To 270 V.
- HOLDING CURRENT = I_H
Suffix 12 = 120mA min.
Suffix 18 = 180mA min.
- PEAK PULSE CURRENT :
 $I_{PP} = 50 \text{ A}, 10/1000 \mu\text{s}.$

DESCRIPTION

The TPAxx series has been designed to protect telecommunication equipments against lightning and transient induced by AC power lines.

IN ACCORDANCE WITH FOLLOWING STANDARDS :

CCITT K17 - K20	{	10/700 μs	1.5 kV
		5/310 μs	38 A
VDE 0433	{	10/700 μs	2 kV
		5/200 μs	50 A
CNET	{	0.5/700 μs	1.5 kV
		0.2/310 μs	38 A

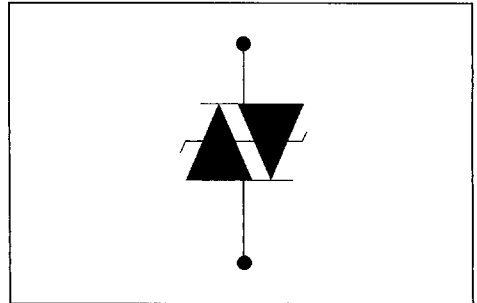
SCHEMATIC DIAGRAM

ABSOLUTE RATINGS (limiting values) ($-40^{\circ}\text{C} \leq T_{\text{amb}} \leq +85^{\circ}\text{C}$)

Symbol	Parameter		Value	Unit
P	Power dissipation on infinite heatsink	$T_{\text{amb}} = 50^{\circ}\text{C}$	1.7	W
I_{PP}	Peak pulse current See note1	10/1000 μs 8/20 μs	50 100	A
I_{TSM}	Non repetitive surge peak on-state current	$t_p = 20 \text{ ms}$	30	A
di/dt	Critical rate of rise of on-state current	Non repetitive	100	A/ μs
dv/dt	Critical rate of rise of off-state voltage	67% V_{BR}	5	KV/ μs
T_{stg} T_J	Storage and operating junction temperature range		- 40 to + 150 + 150	$^{\circ}\text{C}$ $^{\circ}\text{C}$
T_L	Maximum lead temperature for soldering during 10 s.		230	$^{\circ}\text{C}$

THERMAL RESISTANCES

Symbol	Parameter	Value	Unit
$R_{th(j-l)}$	Junction to leads on infinite heatsink.	60	°C/W
$R_{th(j-a)}$	Junction to ambient. on printed circuit. Llead = 10 mm	100	°C/W

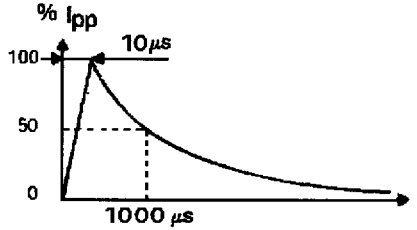
Note 1: 10/1000 μ s wave form.



ELECTRICAL CHARACTERISTICS

Symbol	Parameter
V_{RM}	Stand-off voltage
V_{BR}	Breakdown voltage
V_{BO}	Breakover voltage
I_H	Holding current
V_T	On-state voltage
I_{BO}	Breakover current
I_{PP}	Peak pulse current

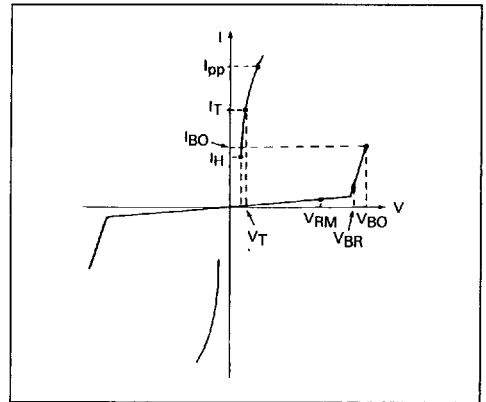

ELECTRICAL CHARACTERISTICS

Type	I_{RM} @ V_{RM}		V_{BR} @ I_R		V_{BO} @ I_{BO}		V_T	C	I_H
	max		min		max	max	max	max	min
	μA	V	V	mA	V	mA	V	pF	note2
P TPA62A - 12 or 18	2	56	62	1	82	300	2	150	Suffix 12 for 120 mA.
TPA62B - 12 or 18	2	56	62	1	75	300	2	150	
P TPA68A - 12 or 18	2	61	68	1	90	300	2	150	
TPA68B - 12 or 18	2	61	68	1	82	300	2	150	
(1) TPA75A - 12 or 18	2	67	75	1	100	300	2	150	
(1) TPA75B - 12 or 18	2	67	75	1	91	300	2	150	
(1) TPA82A - 12 or 18	2	74	82	1	109	300	2	150	
(1) TPA82B - 12 or 18	2	74	82	1	99	300	2	150	
(1) TPA91A - 12 or 18	2	82	91	1	121	300	2	150	
(1) TPA91B - 12 or 18	2	82	91	1	110	300	2	150	
P TPA100A - 12 or 18	2	90	100	1	133	300	2	100	
TPA100B - 12 or 18	2	90	100	1	121	300	2	100	
P TPA110A - 12 or 18	2	99	110	1	147	300	2	100	
TPA110B - 12 or 18	2	99	110	1	133	300	2	100	
P TPA120A - 12 or 18	2	108	120	1	160	300	2	100	Suffix 18 for 180 mA.
TPA120B - 12 or 18	2	108	120	1	145	300	2	100	
P TPA130A - 12 or 18	2	117	130	1	173	300	2	100	
TPA130B - 12 or 18	2	117	130	1	157	300	2	100	
(1) TPA150A - 12 or 18	2	135	150	1	200	300	4	75	
(1) TPA150B - 12 or 18	2	135	150	1	181	300	4	75	
(1) TPA160A - 12 or 18	2	144	160	1	213	300	4	75	
(1) TPA160B - 12 or 18	2	144	160	1	193	300	4	75	
P TPA180A - 12 or 18	2	162	180	1	240	300	4	75	
TPA180B - 12 or 18	2	162	180	1	217	300	4	75	
P TPA200A - 12 or 18	2	180	200	1	267	300	4	75	
TPA200B - 12 or 18	2	180	200	1	241	300	4	75	
P TPA220A - 12 or 18	2	198	220	1	293	300	4	75	
TPA220B - 12 or 18	2	198	220	1	265	300	4	75	
P TPA240A - 12 or 18	2	216	240	1	320	300	4	75	
TPA240B - 12 or 18	2	216	240	1	289	300	4	75	
P TPA270A - 12 or 18	2	243	270	1	360	300	4	75	
TPA270B - 12 or 18	2	243	270	1	325	300	4	75	

All parameters tested at 25°C, except where indicated.

P : Preferred device.

(1): These voltages are on request.

Note 2 : See the reference test circuit for I_H , I_{BO} and V_{BO} parameters.

Note 3 : Square pulse $T_p = 1$ ms - $t_r = 3$ A

Note 4 : $V_R = 1V$, $F = 1MHz$

REFERENCE TEST CIRCUIT FOR I_H , I_{BO} and V_{BO} parameters :

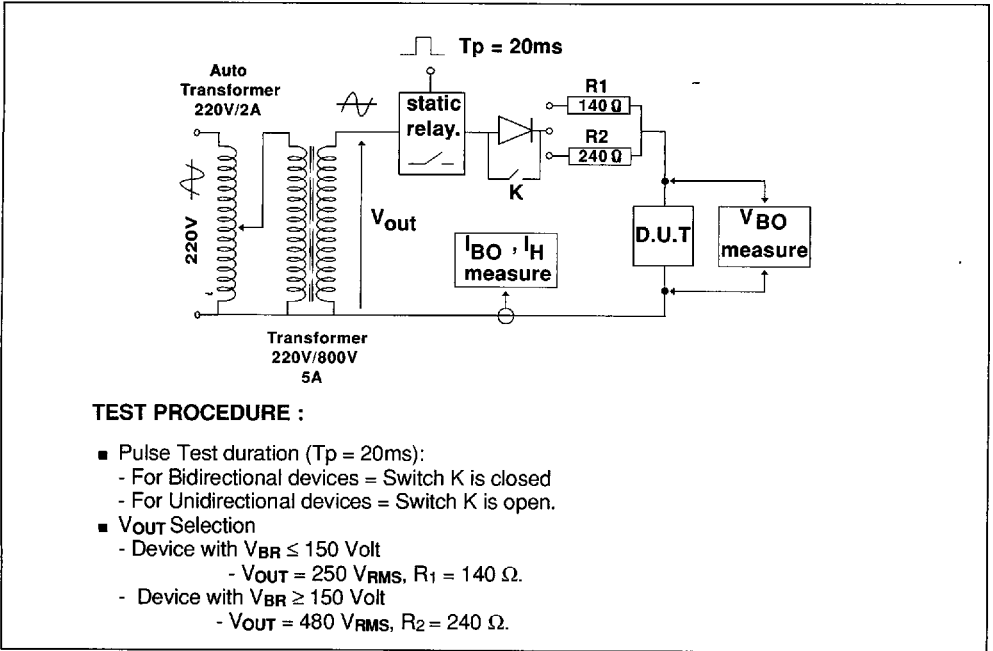

FUNCTIONAL HOLDING CURRENT (I_H) TEST CIRCUIT = GO - NOGO TEST.

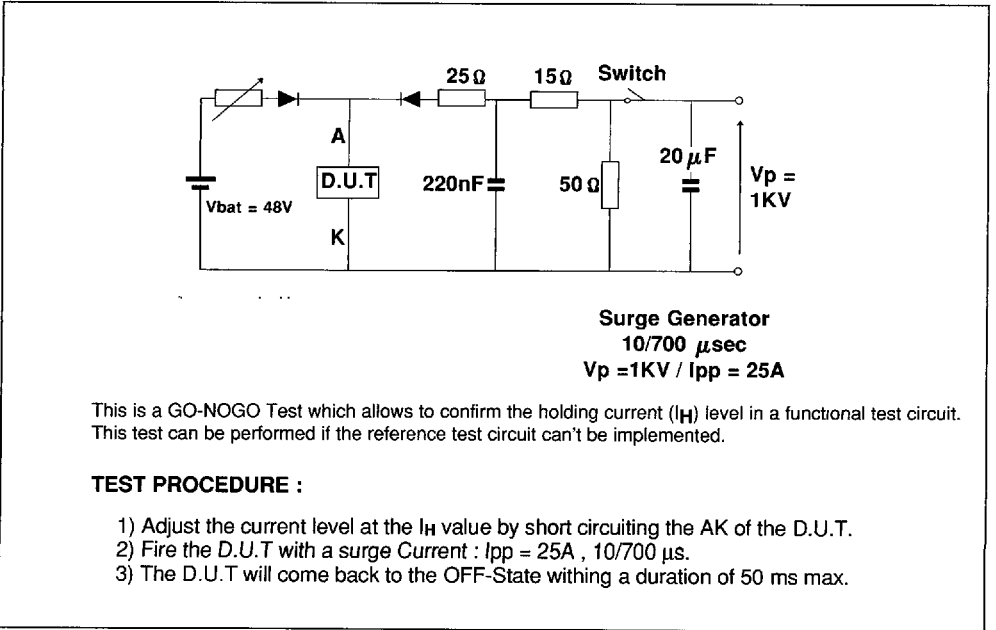
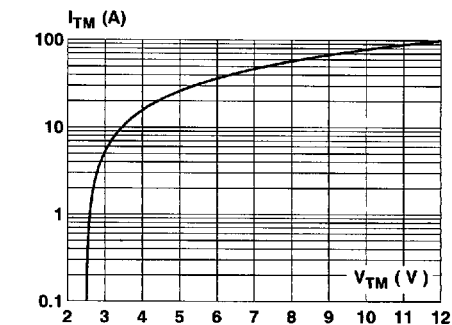
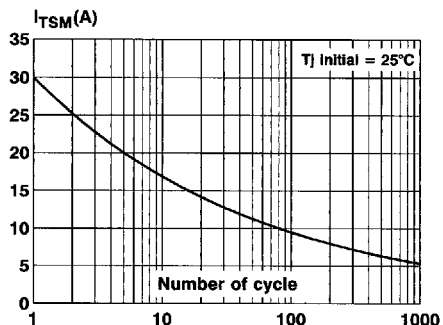

Figure 1 : Non repetitive surge peak on state current versus number of cycles. (with sinusoidal

Figure 2 : On - state characteristics (typical values).



Note : For device with $V_{BR} > 150$ Volt
The V_T value is twice that shown

Figure 3 : Relative variation of holding current versus junction temperature.

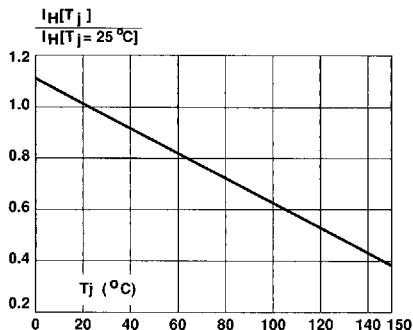

ORDER CODE

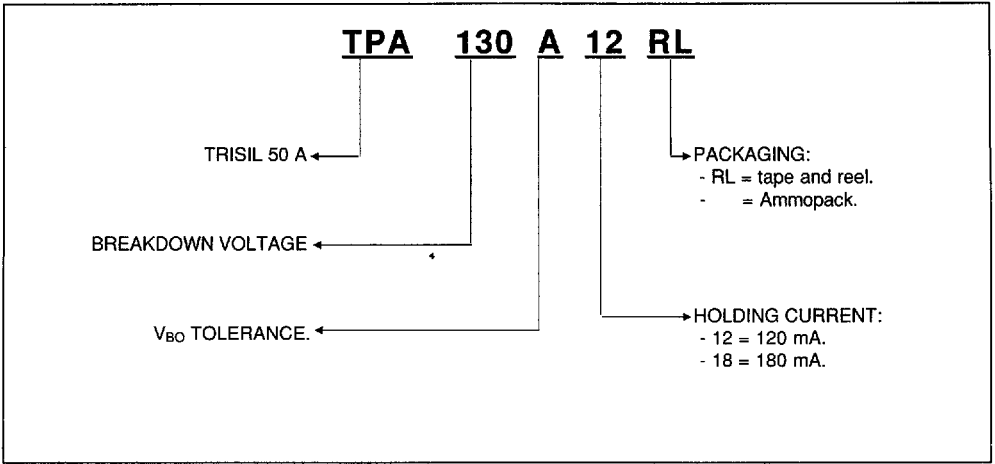

MARKING : Logo, Date Code, Part Number.

PACKAGE MECHANICAL DATA.

F 126 Plastic.

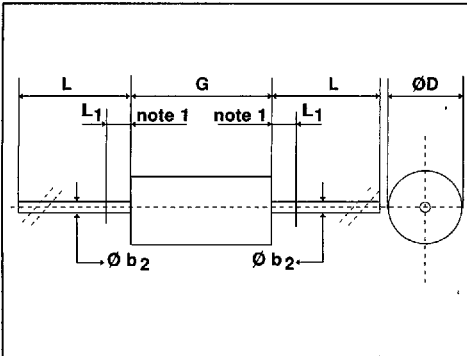

Ref	Millimeters		Inches	
	min	max	min	max
$\varnothing b_2$	0.76	0.86	0.03	0.034
$\varnothing D$	-	3.05	-	0.12
G	-	6.35	-	0.25
L	26	-	1.02	-
L1	-	1.27	-	0.05

note 1: The diameter $\varnothing b_2$ is not controlled over zone L1.

Packaging : Standard packaging is in tape and reel.