



# STMPE1208S

## 12 channel touch key controller

Data Brief

### Features

- 12 touch key capacitive sensor inputs
- 12-bit general purpose Input/Output
- Operating voltage 2.5-5.5V
- 98µA in active mode, 60µA in idle mode
- Dual interrupt output pin
- I2C interface (Up to 400KHz)
- 8kV HBM ESD protection
- Idle and sleep mode for low power operation
- Advanced Filtering System (AFS)
- Environment tracking calibration (ETC)
- Individually adjustable TouchVariance (TVR) setting for all channels
- Adjustable EnvironmentalVariance (EVR) for optimal calibration

### Description

The STMPE1208S is a GPIO 12 channel capacitive touch key sensor able to interface a Main Digital ASIC via the two-line bidirectional bus (I2C). It senses changes in capacitance using a fully digital architecture, giving fast and accurate results at very low power consumption. Automatic Impedance Calibration ensures that changes in environment will never affect the correct operation of the capacitive touch keys.

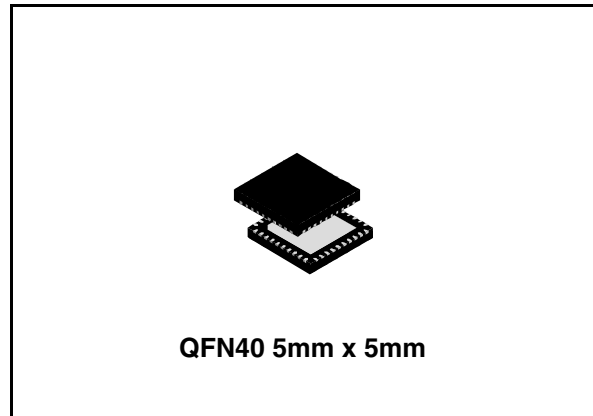

### Applications

- Notebook Computer, Monitor
- Set Top Box, Television
- Portable media player, Game console
- Mobile phone, Smart phone
- Home Entertainment Systems
- Domestic Appliances

Table 1. Device summary

Part Number	Package	Packaging
STMPE1208SQTR	QFN40 5mm x 5mm	Tape and reel

# Contents

<b>1</b>	<b>Block diagram</b> .....	<b>3</b>
<b>2</b>	<b>Pin settings</b> .....	<b>4</b>
	2.1 Pin connection .....	4
	2.2 Pin assignment .....	4
<b>3</b>	<b>Application diagram</b> .....	<b>6</b>
<b>4</b>	<b>Power management</b> .....	<b>7</b>
<b>5</b>	<b>Package mechanical data</b> .....	<b>8</b>
<b>6</b>	<b>Revision history</b> .....	<b>11</b>

# 1 Block diagram

Figure 1. Block diagram

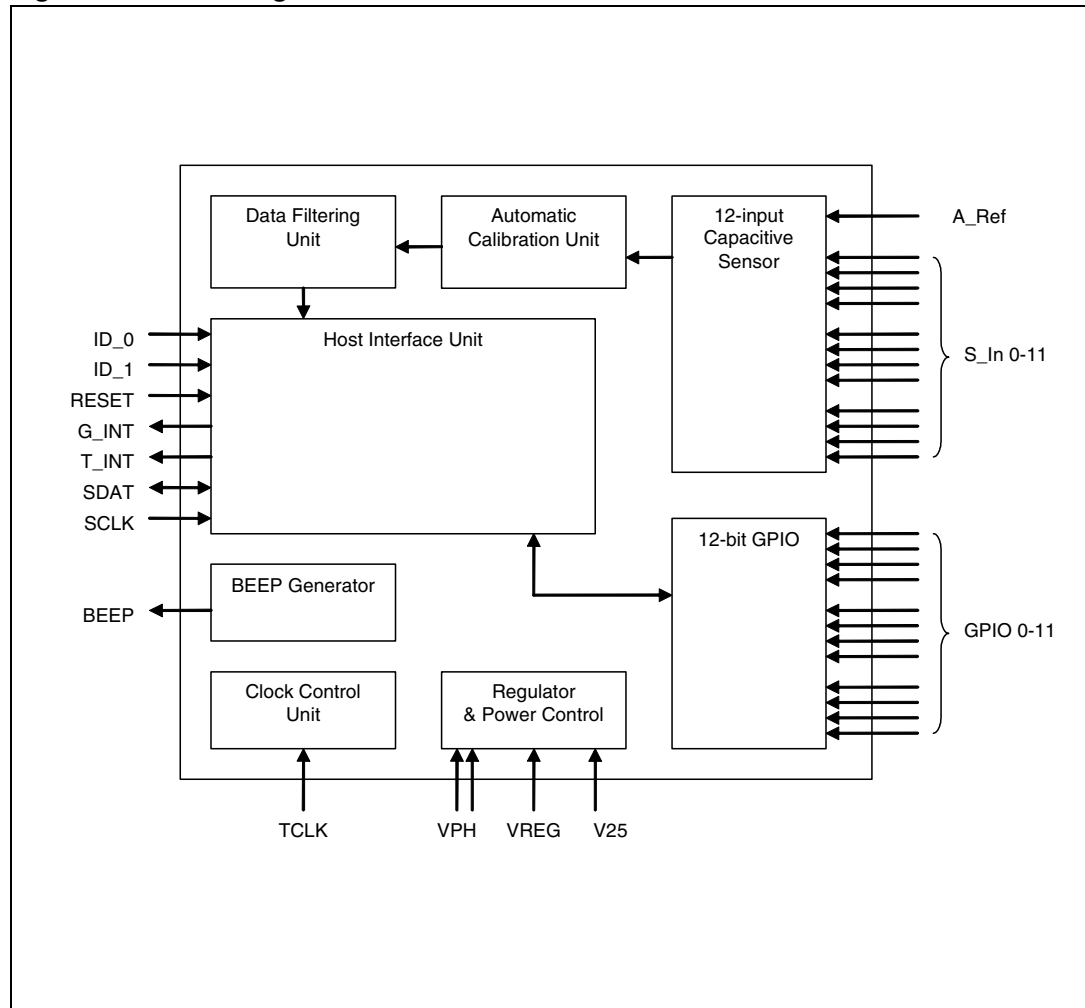

## 2 Pin settings

### 2.1 Pin connection

Figure 2. Pin connection

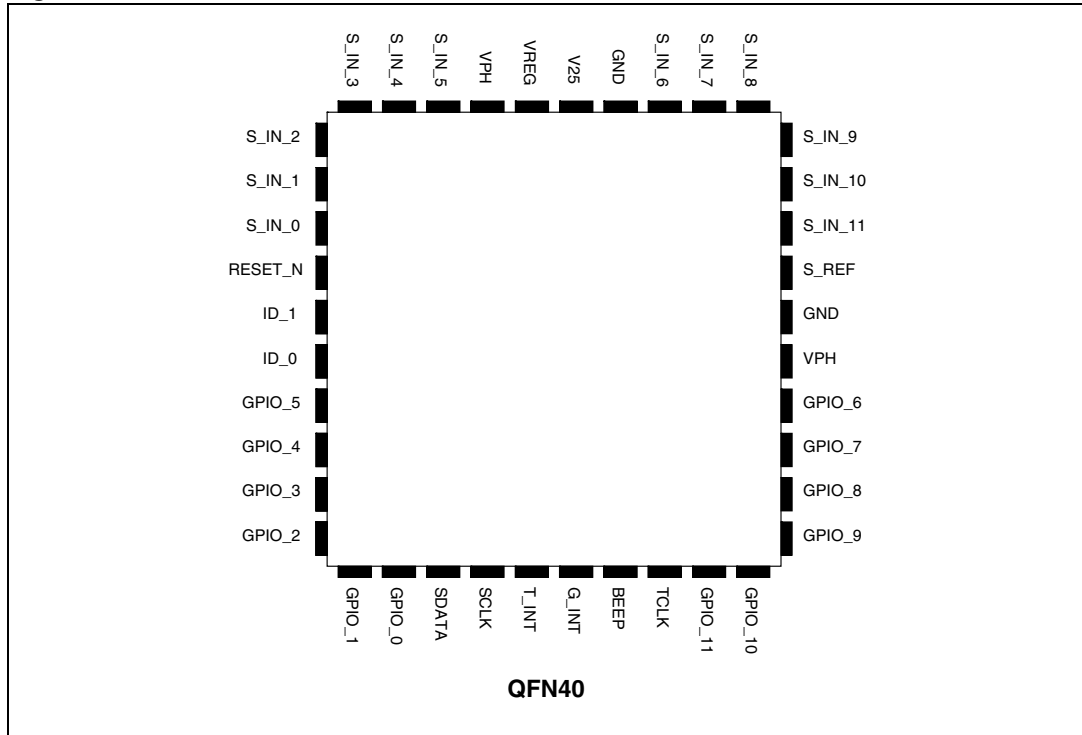

### 2.2 Pin assignment

Table 2. Pin assignment

Pin	Name	Description
1	GPIO_1	General Purpose I/O
2	GPIO_0	General Purpose I/O
3	SDATA	I2C Data
4	SCLK	I2C Clock
5	TINT	Touch Interrupt
6	GINT	General Interrupt
7	BEEP	Beep output
8	TCLK	Test Pin
9	GPIO_11	General Purpose I/O
10	GPIO_10	General Purpose I/O
11	GPIO_9	General Purpose I/O

**Table 2. Pin assignment (continued)**

12	GPIO_8	General Purpose I/O
13	GPIO_7	General Purpose I/O
14	GPIO_6	General Purpose I/O
15	VPH	3-5.5V Power Supply (Regulator Input) Supply to this pin is also used for powering the GPIO
16	GND	GROUND
17	S_REF	Touch Sensing Reference. 1-5pF capacitor for compensation of stray capacitance on board, optional.
18	S_IN_11	Capacitive sensing channel 11
19	S_IN_10	Capacitive sensing channel 10
20	S_IN_9	Capacitive sensing channel 9
21	S_IN_8	Capacitive sensing channel 8
22	S_IN_7	Capacitive sensing channel 7
23	S_IN_6	Capacitive sensing channel 6
24	GND	GROUND
25	V25	2.5V Supply
26	VREG	Internal regulator output
27	VPH	3-5.5V Power Supply (Regulator Input)
28	S_IN_5	Capacitive sensing channel 5
29	S_IN_4	Capacitive sensing channel 4
30	S_IN_3	Capacitive sensing channel 3
31	S_IN_2	Capacitive sensing channel 2
32	S_IN_1	Capacitive sensing channel 1
33	S_IN_0	Capacitive sensing channel 0
34	RESET_N	Active Low Reset
35	ID_1	I2C Address 1
36	ID_0	I2C Address 2
37	GPIO_5	General Purpose I/O
38	GPIO_4	General Purpose I/O
39	GPIO_3	General Purpose I/O
40	GPIO_2	General Purpose I/O

### 3 Application diagram

Figure 3. Application diagram

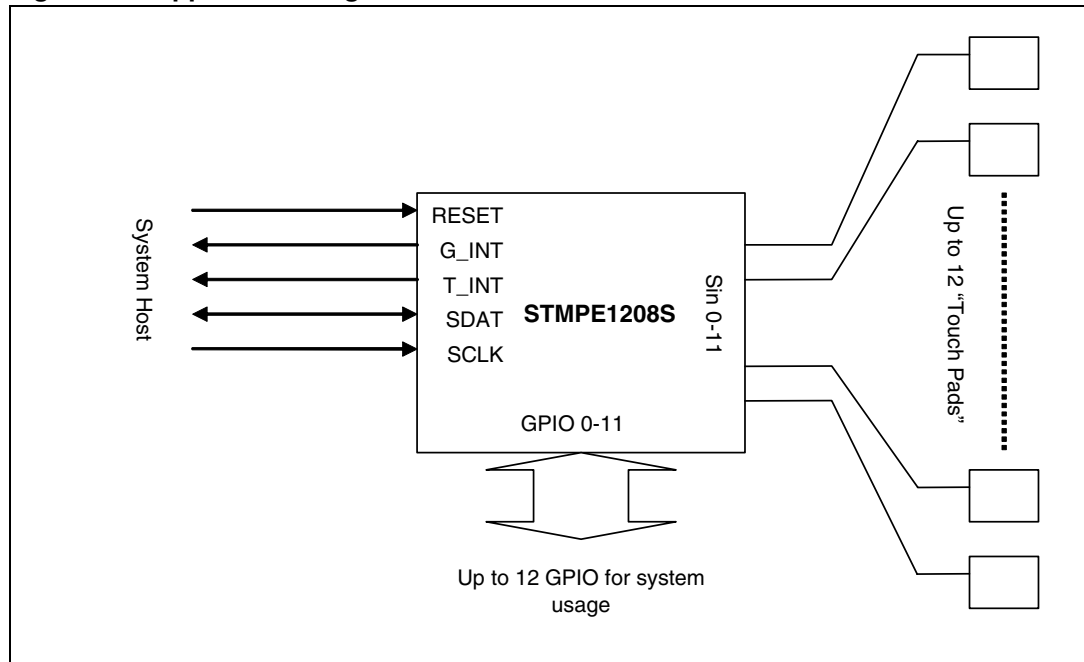

## 4 Power management

STMPE1208S operates in 3 states:

**Figure 4. Power management**

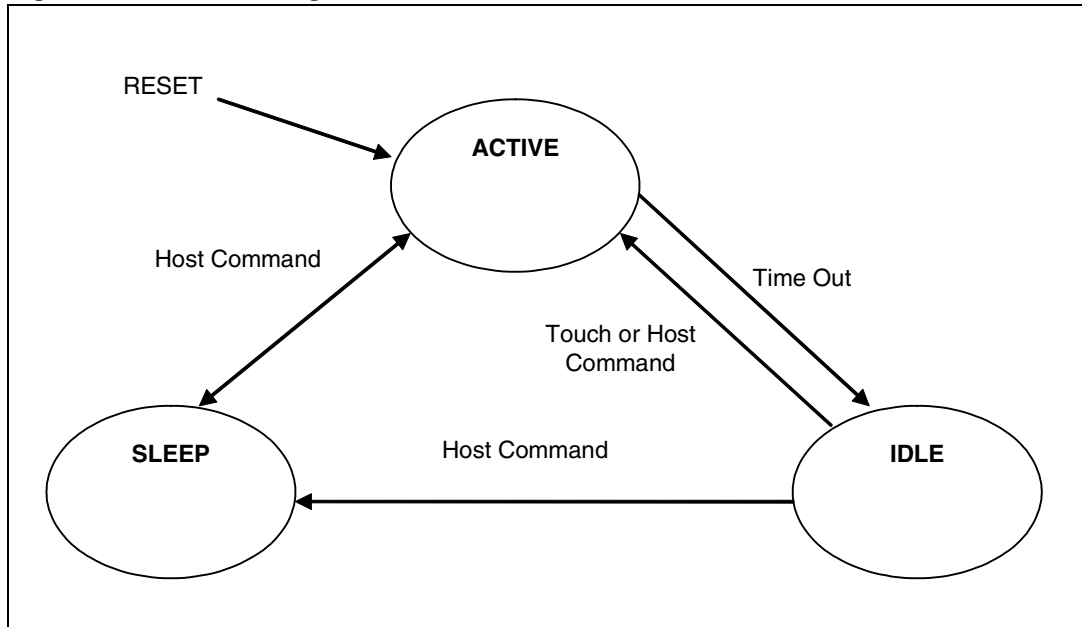

On RESET, STMPE1208S enters ACTIVE state immediately.

Upon a fixed period of inactivity, device enters IDLE state. Any touch activity in IDLE state would cause the device to go back to ACTIVE state.

If no touch activity is expected, host may set the device into SLEEP state to conserve power.

## 5 Package mechanical data

In order to meet environmental requirements, ST offers these devices in ECOPACK® packages. These packages have a Lead-free second level interconnect . The category of second level interconnect is marked on the package and on the inner box label, in compliance with JEDEC Standard JESD97. The maximum ratings related to soldering conditions are also marked on the inner box label. ECOPACK is an ST trademark. ECOPACK specifications are available at: [www.st.com](http://www.st.com)

**Table 3. QFN40 5mm x 5mm Mechanical data**

Dim.	mm.		
	Min	Typ	Max
A	0.80	0.85	0.90
A1	0.00		0.05
A3	0.203 ref		
b	0.15	0.20	0.25
D	5.00 BSC		
E	5.00 BSC		
D2	3.70	3.80	3.90
E2	3.70	3.80	3.90
e	0.40 BSC		
L	0.30	0.35	0.40
L1			0.10
P		45° BSC	
aaa		0.15	
ccc		0.10	



Figure 5. Package dimensions

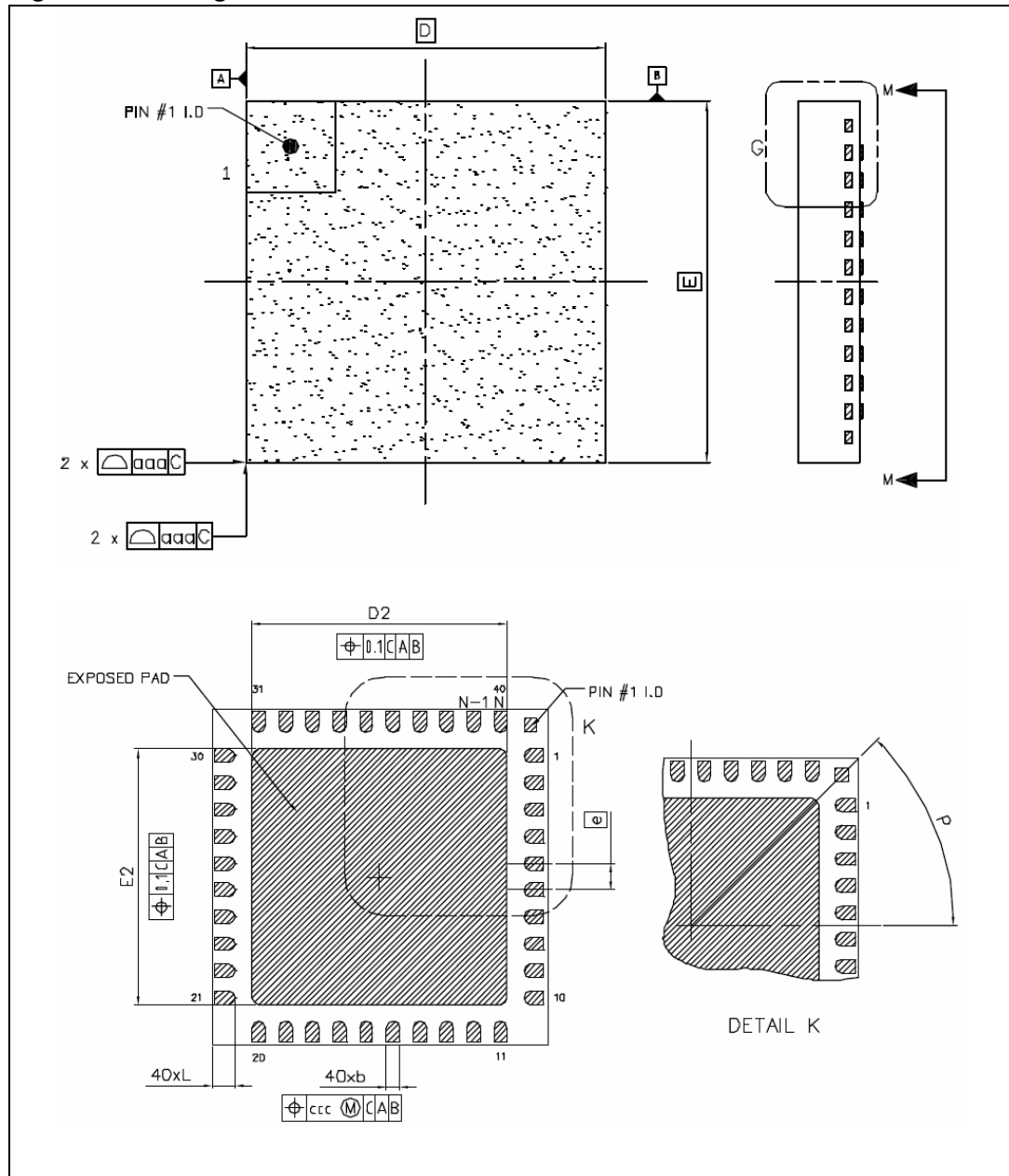
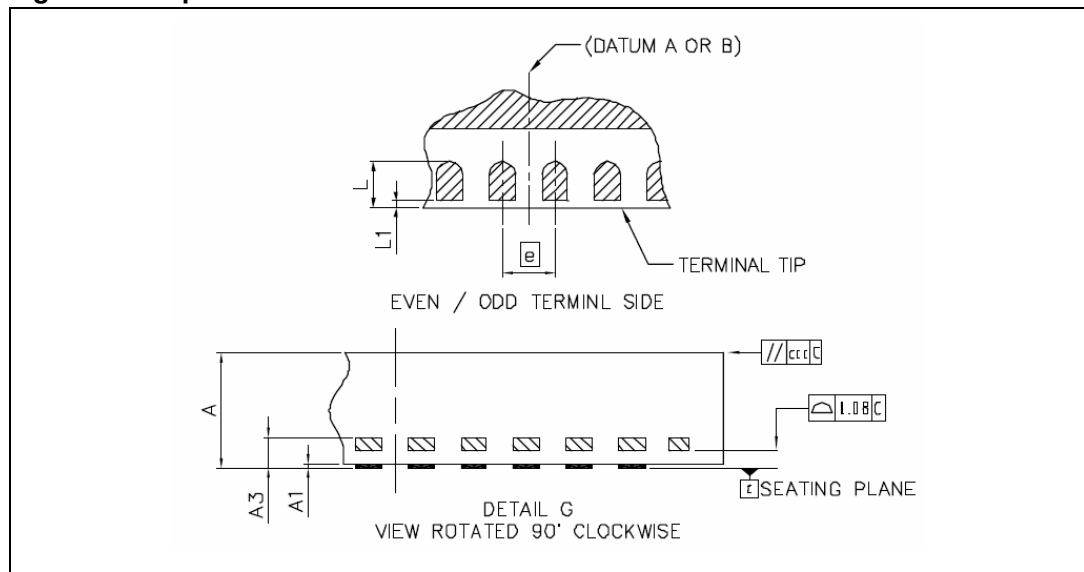

Figure 6. Tape and reel



## 6 Revision history

Table 4. Revision history

Date	Revision	Changes
19-Jun-2007	1	Initial release

**Please Read Carefully:**

Information in this document is provided solely in connection with ST products. STMicroelectronics NV and its subsidiaries ("ST") reserve the right to make changes, corrections, modifications or improvements, to this document, and the products and services described herein at any time, without notice.

All ST products are sold pursuant to ST's terms and conditions of sale.

Purchasers are solely responsible for the choice, selection and use of the ST products and services described herein, and ST assumes no liability whatsoever relating to the choice, selection or use of the ST products and services described herein.

No license, express or implied, by estoppel or otherwise, to any intellectual property rights is granted under this document. If any part of this document refers to any third party products or services it shall not be deemed a license grant by ST for the use of such third party products or services, or any intellectual property contained therein or considered as a warranty covering the use in any manner whatsoever of such third party products or services or any intellectual property contained therein.

**UNLESS OTHERWISE SET FORTH IN ST'S TERMS AND CONDITIONS OF SALE ST DISCLAIMS ANY EXPRESS OR IMPLIED WARRANTY WITH RESPECT TO THE USE AND/OR SALE OF ST PRODUCTS INCLUDING WITHOUT LIMITATION IMPLIED WARRANTIES OF MERCHANTABILITY, FITNESS FOR A PARTICULAR PURPOSE (AND THEIR EQUIVALENTS UNDER THE LAWS OF ANY JURISDICTION), OR INFRINGEMENT OF ANY PATENT, COPYRIGHT OR OTHER INTELLECTUAL PROPERTY RIGHT.**

**UNLESS EXPRESSLY APPROVED IN WRITING BY AN AUTHORIZED ST REPRESENTATIVE, ST PRODUCTS ARE NOT RECOMMENDED, AUTHORIZED OR WARRANTED FOR USE IN MILITARY, AIR CRAFT, SPACE, LIFE SAVING, OR LIFE SUSTAINING APPLICATIONS, NOR IN PRODUCTS OR SYSTEMS WHERE FAILURE OR MALFUNCTION MAY RESULT IN PERSONAL INJURY, DEATH, OR SEVERE PROPERTY OR ENVIRONMENTAL DAMAGE. ST PRODUCTS WHICH ARE NOT SPECIFIED AS "AUTOMOTIVE GRADE" MAY ONLY BE USED IN AUTOMOTIVE APPLICATIONS AT USER'S OWN RISK.**

Resale of ST products with provisions different from the statements and/or technical features set forth in this document shall immediately void any warranty granted by ST for the ST product or service described herein and shall not create or extend in any manner whatsoever, any liability of ST.

ST and the ST logo are trademarks or registered trademarks of ST in various countries.

Information in this document supersedes and replaces all information previously supplied.

The ST logo is a registered trademark of STMicroelectronics. All other names are the property of their respective owners.

© 2007 STMicroelectronics - All rights reserved

STMicroelectronics group of companies

Australia - Belgium - Brazil - Canada - China - Czech Republic - Finland - France - Germany - Hong Kong - India - Israel - Italy - Japan - Malaysia - Malta - Morocco - Singapore - Spain - Sweden - Switzerland - United Kingdom - United States of America

[www.st.com](http://www.st.com)