



VV5301-VV6301 Digital Output Sensor

The VV5301 and VV6301 sensors are highly integrated digital output imaging devices based on STMicroelectronics unique CMOS sensor technology. Both sensors require minimal support circuitry.

VV5301 (monochrome) and VV6301 (colourised) sensors produce digital video output. The video streams from both devices contain embedded control data that can be used in frame grabbing applications

The pixel array in the VV6301 device is coated with dyes forming a Bayer colour pattern. The sensors require software to perform colour processing before an image may be displayed.

Automatic Black Level Calibration

The sensor can perform automatic black level calibration to remove voltage offsets in the video signal path that lead to offsets in the output image. These offsets are removed using 2 Digital to Analogue Convertors (DACs). The automatic black calibration algorithm monitors the average level of the sensor black pixels and adjusts the input level to the 2 DACs to remove the offset.

Serial Interface

A 2 wire serial interface allows the master coprocessor to reconfigure the device.

KEY FEATURES

- Low cost digital imager
- QSIF resolution sensor
- Automatic exposure/gain control
- Dual digital output formats available
- 2 wire serial communications
- On board 8bit ADC
- On board voltage regulator
- Automatic black level calibration
- Variable frame rate
- Reduced flicker operating modes

APPLICATIONS

- Toys
- Automotive systems
- Personal video communications
- Biometric readers

SPECIFICATIONS

DEVICE FUNCTIONALITY

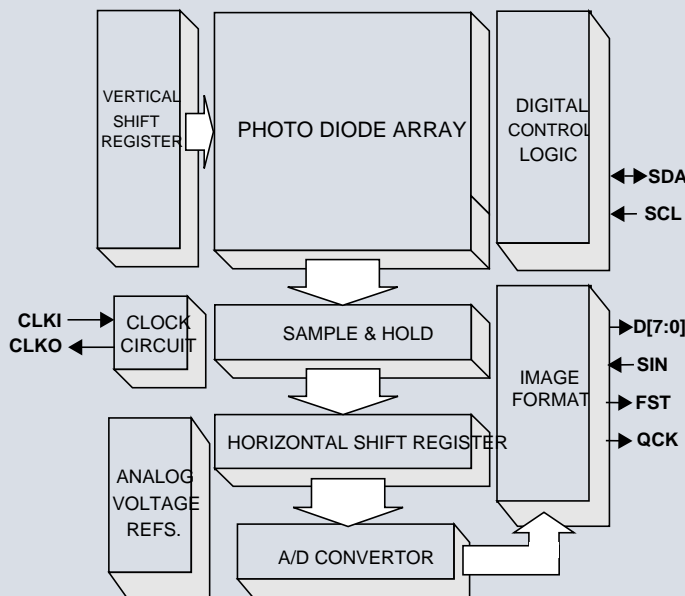

Maximum pixel resolution	164 x 124
Effective image size after colour processing	160 x 120
Pixel size	12.0µm x 12.0µm
Array size	1.92mm x 1.44mm
Exposure control	+44dB
Analogue gain	+18dB
Signal/Noise ratio	44dB
Supply voltage	5V DC +/- 5%
Supply current VV5301-VV6301	2.9mA (standby) 14.6mA (active)
Operating temperature (ambient)	0°C - 40°C (for extended temperature information please contact ST)
Package type	48BGA



VV5301-VV6301 Digital Output Sensors

EXAMPLE APPLICATIONS

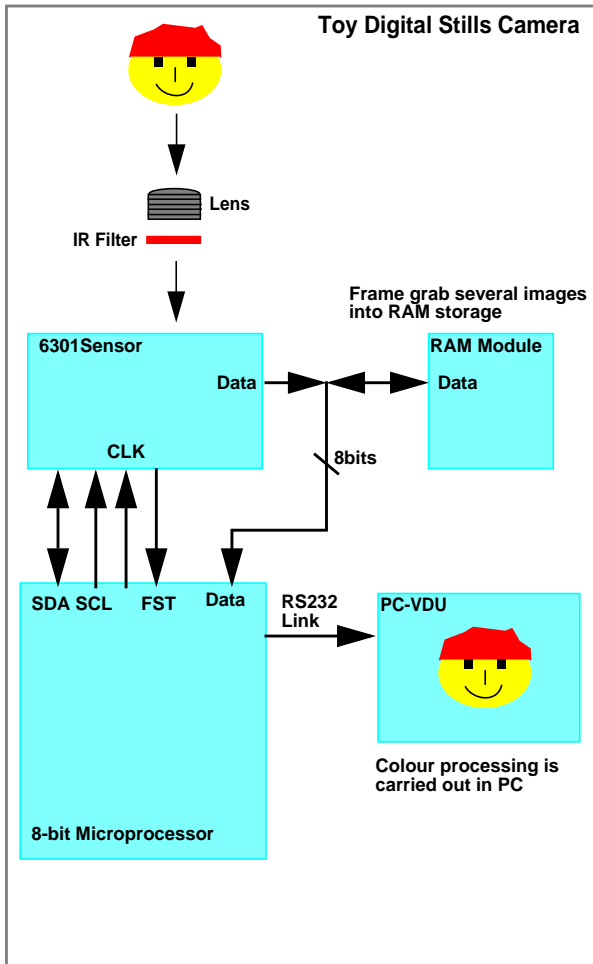

EVALUATION KITS

STMicroelectronics recommend using their Evaluation Kits for initial evaluation and design-in of sensors. For the VV5301 and VV6301 there are two Kits, a Mono and a colour EVK. Each kit comprises a lensed camera head board camera, an interface PCB, a short form PCI card and required cabling. Software is provided to control the sensor operation from a PC.

ABOUT VISION & IMAGING TECHNOLOGY

Our unique CMOS technology enables integration of the sensor array and associated support circuitry on a single VLSI microchip. CMOS sensors are compact, highly integrated devices that require reduced power consumption over traditional CCD devices while offering equivalent image quality.

STMicroelectronics is a leading supplier of CMOS image sensors. The VV5301-VV6301 sensors are part of a comprehensive range of image sensing products for applications including videoconferencing, digital stills cameras, toys, security and biometrics. Visit our web site at www.st.com for more information.

ORDERING DETAILS

Part Number	Description	Number of defects
VV5301B003	48BGA packaged, QSIF Monochrome	up to 32
VV6301B003	48BGA packaged, QSIF ColourMOS	up to 32
STV-5301-E01	Evaluation Kit for VV5301	N/A
STV-6301-E01	Evaluation Kit for VV6301	N/A

Information furnished is believed to be accurate and reliable. However, STMicroelectronics assumes no responsibility for the consequences of use of such information nor for any infringement of patents or other rights of third parties which may result from its use. No license is granted by implication or otherwise under any patent or patent rights of STMicroelectronics. Specifications mentioned in this publication are subject to change without notice. This publication supersedes and replaces all information previously supplied. STMicroelectronics products are not authorized for use as critical components in life support devices or systems without express written approval of STMicroelectronics
 The ST logo is a registered trademark of STMicroelectronics
 © 2000STMicroelectronics - All Rights Reserved
 The ST logo is a registered trademark