



16K x 68-bit Entry NETWORK SEARCH ENGINE

DATA BRIEFING

FEATURES SUMMARY

- 16K ENTRIES IN 68-BIT MODE
- TABLE MAY BE PARTITIONED INTO UP TO FOUR (4) QUADRANTS
(Data entry width in each quadrant is configurable as 34, 68, 136, or 272 bits.)
- UP TO 83 MILLION SUSTAINED SEARCHES PER SECOND IN 68-BIT and 136-BIT CONFIGURATIONS
- UP TO 41.5 MILLION SEARCHES PER SECOND IN 34-BIT and 272-BIT CONFIGURATIONS
- SEARCHES ANY SUB-FIELD IN A SINGLE CYCLE
- OFFERS BIT-BY-BIT and GLOBAL MASKING
- SYNCHRONOUS, PIPELINED OPERATION
- UP TO 31 SEARCH ENGINES CASCADABLE WITHOUT PERFORMANCE DEGRADATION
- WHEN CASCADED, THE DATABASE ENTRIES CAN SCALE FROM 124K to 992K DEPENDING ON THE SIZE OF THE ENTRY
- GLUELESS INTERFACE TO INDUSTRY-STANDARD SRAMS
- SIMPLE HARDWARE INSTRUCTION INTERFACE
- IEEE 1149.1 TEST ACCESS PORT
- OPERATING SUPPLY VOLTAGES INCLUDE:
V_{DD} (Operating Supply Voltage) = 1.8V
V_{DDQ} (Operating Supply Voltage for I/O) = 2.5 or 3.3V
- 272 BALL, 27mm x 27mm, CAVITY-UP BGA

Figure 1. 272-ball PBGA Package

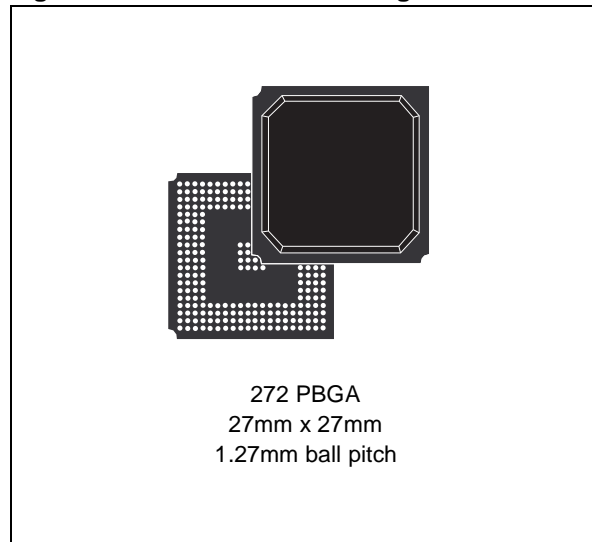

M7010

DESCRIPTION

Overview

The M7010 is a feature-rich hardware search engine optimized for networking and communications applications. It incorporates leading-edge Associative Processing Technology (APT, trademark of Cypress Semiconductor, Inc.) and Advanced Power Management. The data table may be partitioned into up to four (4) quadrants, allowing the user to configure each quadrant with different table entry widths (x34, x68, x136, or x272-bit). It is also programmable to accelerate performance.

Performance

The M7010 outperforms competitive solutions using software sequential search algorithms in conjunction with SRAMs or ASICs, or hardware implementation with ASICs and CAMs. The latter solution, while faster than a software-based solution, still suffers from performance degradation

when depth-cascaded and is unable to scale to next-generation requirements. The M7010-based solutions overcome all of these drawbacks.

Applications

The performance and features of the M7010 makes it ideal in applications such as enterprise LAN switches, broadband switching and routing equipment, supporting multiple data rates from OC-48 and beyond.

Figure 2 illustrates how a search engine subsystem can be optimized using a host bridge ASIC (or a dedicated co-processor, such as the Cypress Semiconductor LNI8010), the M7010, and synchronous or non-synchronous SRAMs. It also illustrates how this system fits into a switch-router implementation.

Table 1. Product Range

Part Number	Operating Supply Voltage	Operating I/O Voltage	Speed
M7010R-083ZA1	1.8V	2.5 or 3.3V	83MHz
M7010R-066ZA1	1.8V	2.5 or 3.3V	66MHz

Figure 2. Switch/Router Implementation Using the M7010

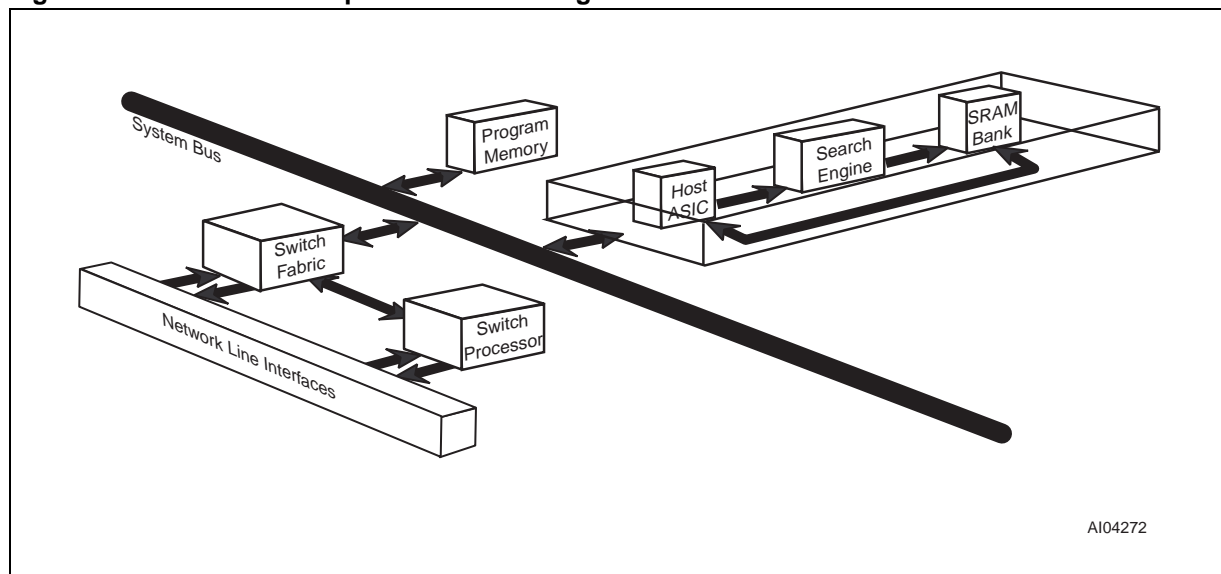

AI04272

Table 2. Signal Names

Symbol	Type	Connection Name
Clocks and Reset		
CLK2X	I	Master Clock
PHS_L	I	Phase
RST_L	I	Reset
Command and DQ Bus		
CMD[8:0]	I	Command Bus
CMDV	I	Command Valid
DQ[67:0]	I/O	Address/Data Bus
ACK ⁽¹⁾	T	READ Acknowledge
EOT ⁽¹⁾	T	End of Transfer
SSF	T	SEARCH Successful Flag
SSV	T	SEARCH Successful Flag Valid
SADR[21:0]	T	SRAM Address
CE_L	T	SRAM Chip Enable
WE_L	T	SRAM WRITE Enable
OE_L	T	SRAM Output Enable
ALE_L	T	Address Latch Enable

Cascade Interface		
LHI[6:0]	I	Local Hit In
LHO[1:0]	O	Local Hit Out
BHI[2:0]	I	Block Hit In
BHO[2:0]	O	Block Hit Out
FULI[6:0]	I	Full In
FULO[1:0]	O	Full Out
FULL	O	Full Flag
Device Identification		
ID[4:0]	I	Device Identification
Test Access Port		
TDI	I	Test Access Port's Test Data In
TCK	I	Test Access Port's Test Clock
TDO	T	Test Access Port's Test Data Out
TMS	I	Test Access Port's Test Mode Select
TRST_L	I	Test Access Port's Reset

Note: Signal types are: I = Input only; I/O = Input or Output; O = Output; and T = Tristate

1. ACK and EOT Signals require a pull-down resistor of 47 ohms.

Figure 3. Connections

NC	GND	EOT	NC	NC	V _{DD}	FULI5	FULI4	FULI1	BHO0	V _{DD}	BHI0	LHI6	NC	V _{DD}	ID2	ID0	TDO	NC	NC	
NC	NC	ACK	FULL	NC	FULO1	NC	FULI6	FULI2	BHO1	BHI2	V _{DDQ}	LHI5	LHI3	LHI2	ID3	TMS	TDI	V _{DD}	NC	
DQ64	NC	NC	V _{DDQ}	V _{DD}	V _{DDQ}	NC	NC	V _{DDQ}	BHO2	V _{DD}	LHO1	LHI4	V _{DDQ}	LHI0	ID1	TCK	NC	NC	DQ65	
DQ62	NC	V _{DD}	GND	RSTL	NC	FULO0	GND	FULI3	FULI0	BHI1	LHO0	GND	LHI1	ID4	T _{RST_L}	GND	DQ63	DQ61	DQ57	
DQ60	V _{DDQ}	NC	DQ66	TOP												DQ67	DQ59	NC	DQ53	
V _{DD}	NC	DQ56	DQ58													V _{DDQ}	DQ55	DQ49	V _{DD}	
DQ50	V _{DDQ}	DQ52	DQ54													DQ47	V _{DDQ}	DQ51	V _{DDQ}	
NC	DQ46	DQ48	GND													GND	NC	DQ45	DQ43	
DQ40	DQ42	V _{DDQ}	DQ44													DQ41	DQ39	V _{DD}	DQ37	
V _{DD}	NC	DQ36	DQ38	LEFT	GND				GND				RIGHT				V _{DDQ}	DQ35	DQ33	DQ31
V _{DDQ}	DQ34	DQ32	DQ30													V _{DDQ}	NC	DQ29	V _{DD}	
NC	DQ28	V _{DDQ}	DQ26													NC	DQ23	DQ25	DQ27	
DQ24	V _{DD}	DQ20	GND													GND	DQ19	V _{DDQ}	DQ21	
DQ22	DQ16	DQ14	V _{DDQ}													V _{DDQ}	NC	DQ15	DQ17	
V _{DD}	DQ18	V _{DDQ}	DQ6													DQ9	DQ11	DQ13	V _{DD}	
NC	DQ12	DQ8	DQ0	BOTTOM												DQ1	DQ5	DQ7	NC	
DQ10	NC	V _{DDQ}	GND	NC	CMD2	CMD4	GND	WE_L	CLK2X	V _{DD}	SADR ₁₅	GND	V _{DDQ}	SADR ₅	V _{DDQ}	GND	NC	NC	V _{DDQ}	
DQ2	DQ4	V _{DD}	SSF	CMD6	CMD3	CMD0	AE_L	OE_L	SADR ₂₁	SADR ₁₈	SADR ₁₆	SADR ₁₂	SADR ₉	SADR ₇	SADR ₆	NC	SADR ₀	V _{DD}	DQ3	
NC	NC	NC	SSV	CMD5	CMD1	CMDV	V _{DDQ}	PHS_L	V _{DDQ}	SADR ₁₉	V _{DDQ}	NC	SADR ₁₀	SADR ₁₁	NC	SADR ₄	SADR ₃	NC	NC	
NC	NC	CMD8	CMD7	V _{DDQ}	V _{DD}	NC	CE_L	NC	V _{DD}	SADR ₂₀	SADR ₁₇	SADR ₁₄	SADR ₁₃	V _{DD}	SADR ₈	V _{DDQ}	SADR ₂	SADR ₁	NC	

AI04270



Figure 4. M7010 Block Diagram

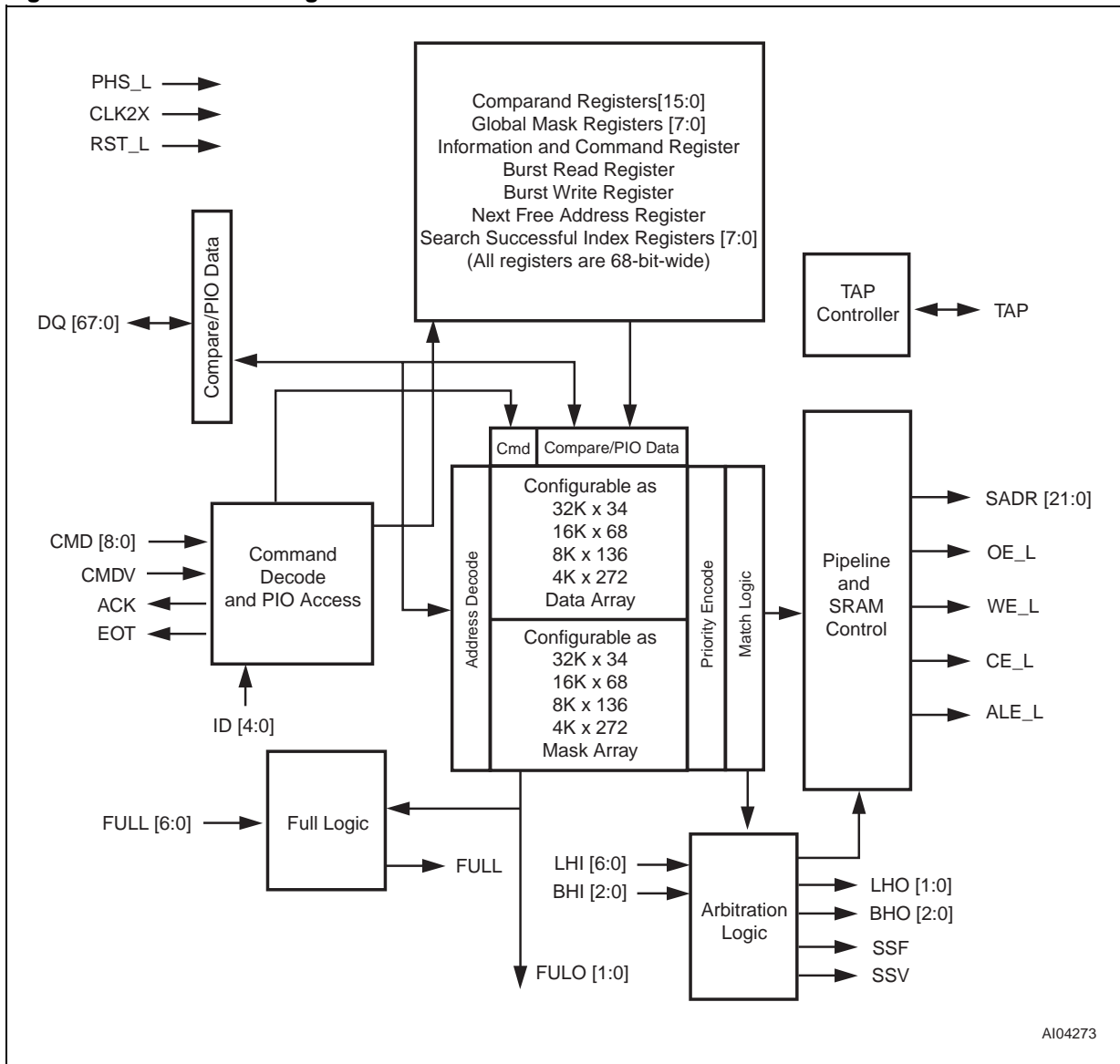

AI04273

PART NUMBERING

Table 3. Ordering Information Scheme

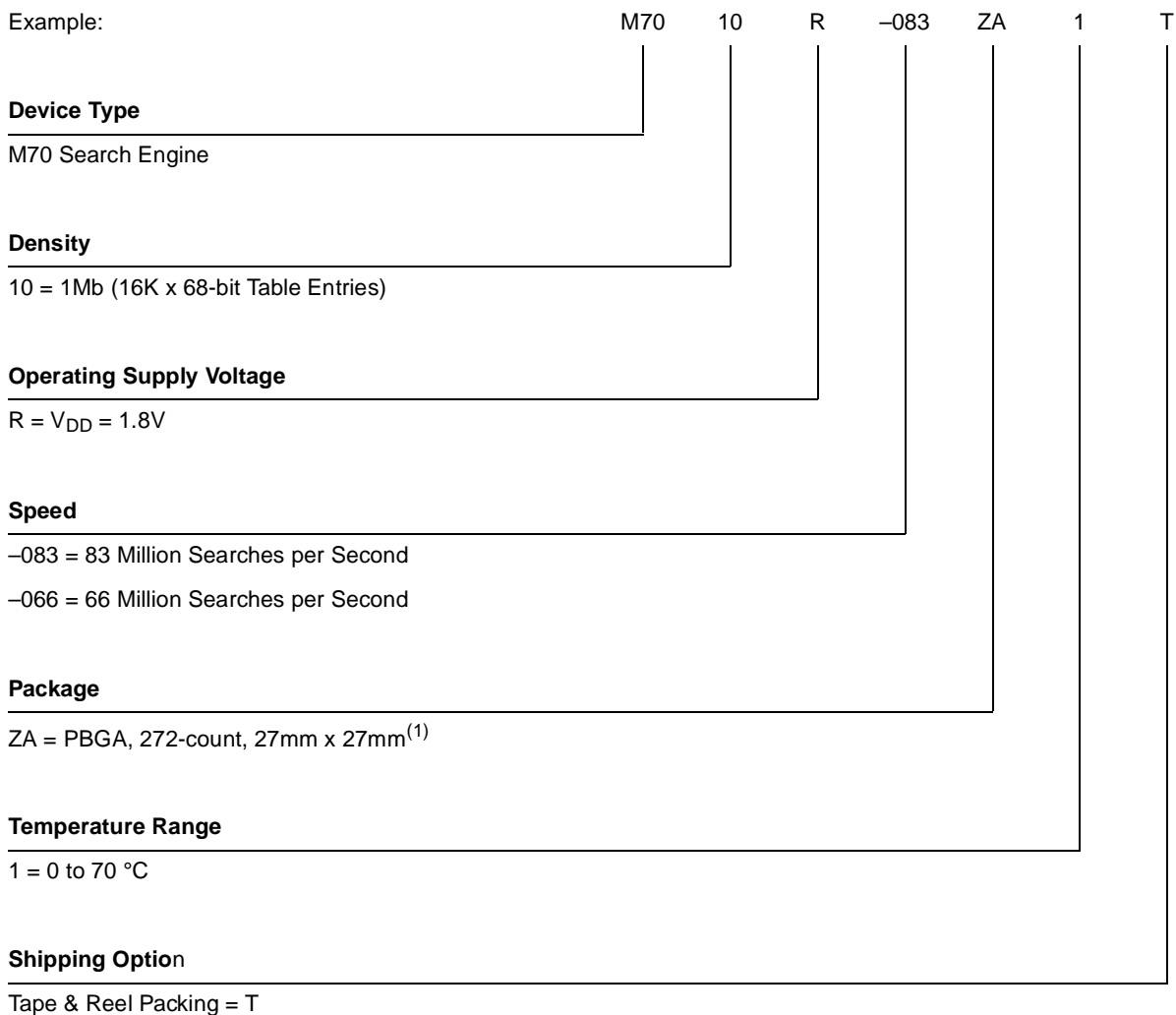

Note: 1. Where "Z" is the symbol for BGA packages and "A" denotes 1.27mm ball pitch

For a list of available options (e.g., Speed, Package) or for further information on any aspect of this device, please contact the ST Sales Office nearest to you.