



## 4-BIT MICROCONTROLLER

### 1. GENERAL DESCRIPTION

The W742C814 is a high-performance 4-bit micro-controller ( $\mu\text{C}$ ) that provides an LCD driver. The device contains a 4-bit ALU, two 8-bit timers, two dividers (for two oscillators) in dual-clock operation, a  $32 \times 4$  LCD driver, five 4-bit I/O ports (including 1 output port for LED driving), and one channel DTMF generator. There are also five interrupt sources and 8-levels subroutine nesting for call subroutine or interrupt applications. The W742C814 operates on very low current and has two power reduction modes, that is the dual-clock slow operation and STOP mode, which help to minimize power dissipation.

### 2. FEATURES

- Operating voltage: 2.4V - 5.5V
- Dual-clock operation
- Main-oscillator
  - Connect to 3.58 MHz crystal or 400 KHz that can be selected by option code
  - Connect to 2 MHz typical RC oscillator
- Sub-oscillator
  - Connect to 32768 Hz crystal only
- Memory
  - 4096 x 16 bits program ROM (including 16K x 4 bit look-up table)
  - 1024 x 4 bits data RAM (including 16 nibbles x 16 pages working registers)
  - 32 x 4 LCD data RAM
- 20 input/output pins
  - Port for input only: 1 ports/4 pins (RC)
  - Input/output ports: 3 ports/12 pins (RA, RB & RD)
  - High sink current output port for LED driving: 1 port / 4 pins (RE)
- Power-down mode
  - Hold function: no operation (excluding main-oscillator and sub-oscillator)
  - Stop function: no operation (main-oscillator and sub-oscillator are stopped)
  - Dual-clock slow operation mode: system is operated by the sub-oscillator (FOSC = Fs and Fm is stopped)
- Five types of interrupts
  - Four internal interrupts (Divider0, Divider1, Timer 0, Timer 1)
  - One external interrupts (RC Port)



- LCD driver output
  - 32 segments x 4 commons
  - 1/4 duty 1/3 bias driving mode
  - Clock source should be the sub-oscillator clock in the dual-clock operation mode or  $F_{osc}/128$  in the single-clock operation mode
- MFP output pin
  - Output is software selectable as modulating or non-modulating frequency
  - Works as frequency output specified by Timer 1
- DTMF output pin
  - Output is one channel Dual Tone Multi-Frequency signal for dialing
- Two built-in 14-bit frequency dividers
  - Divider0: the clock source is the output of the main-oscillator
  - Divider1: the clock source is the output of the sub-oscillator (for dual-clock option) or the  $F_{osc}/128$  (for single-clock option)
- Two built-in 8-bit programmable countdown timers
  - Timer 0: one of two internal clock frequencies ( $F_{osc}/4$  or  $F_{osc}/1024$ ) can be selected
  - Timer 1: with auto-reload function and one of three internal clock frequencies ( $F_{osc}$ ,  $F_{osc}/64$  or  $F_s$ ) can be selected by MR1 register; and the specified frequency can be delivered to MFP pin
- Built-in 18/15-bit watchdog timer selectable for system reset; enable the watch dog timer or not is determined by code option
- Powerful instruction set: 142 instructions
- 8-levels subroutine (include interrupt) nesting
- Packaged in: 80-pin QFP, 100-Pin QFP

# Preliminary W742C814



## 3. PIN CONFIGURATIONS

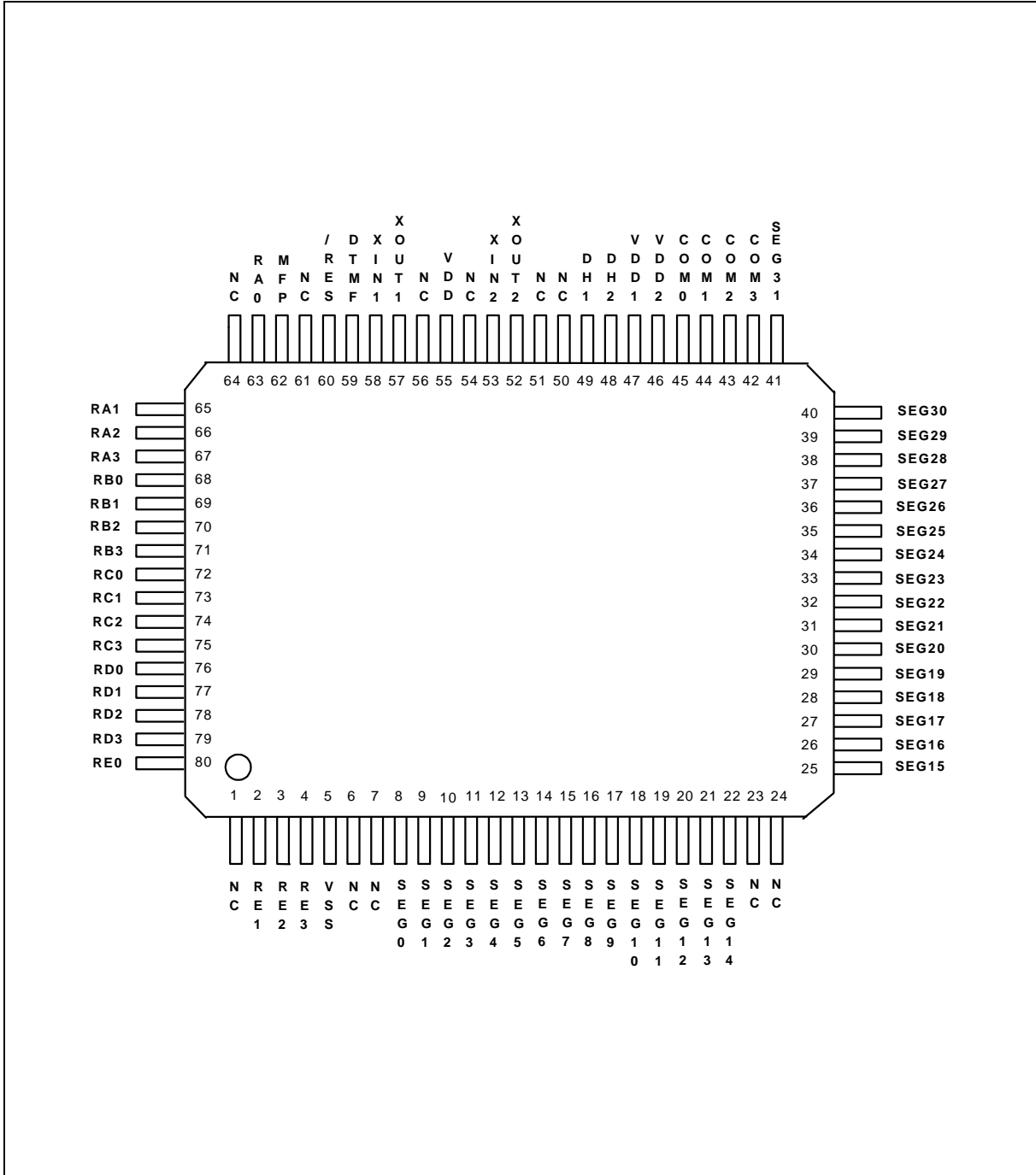

80-pin QFP

# Preliminary W742C814



Pin Configurations, continued

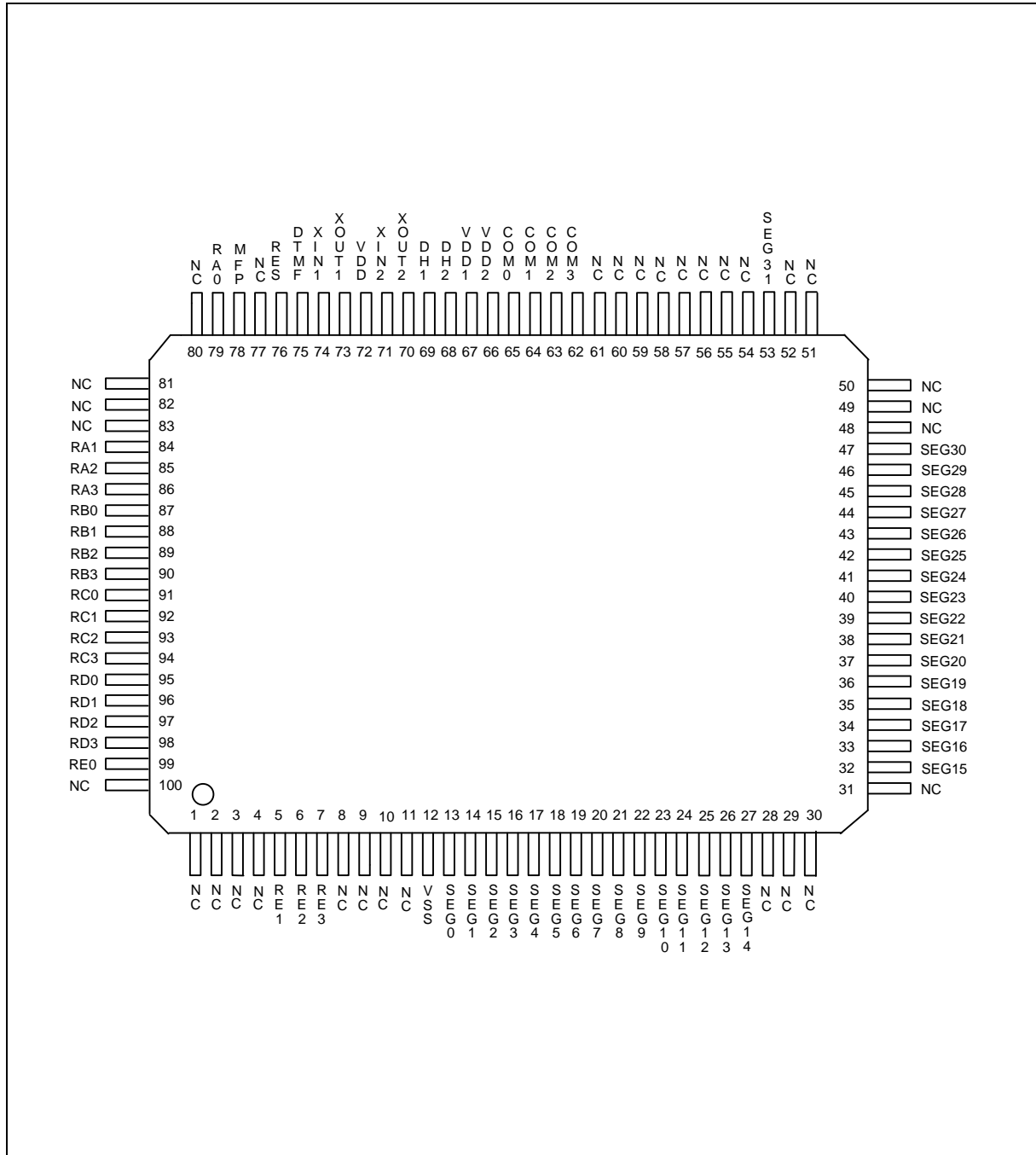

100-pin QFP



## 4. PIN DESCRIPTION

SYMBOL	I/O	FUNCTION
XIN2	I	Input pin for sub-oscillator. Connected to 32.768 KHz crystal only.
XOUT2	O	Output pin for sub-oscillator with internal oscillation capacitor. Connected to 32.768 KHz crystal only.
XIN1	I	Input pin for main-oscillator. Connected to 3.58 MHz or 400 KHz crystal or RC to generate system clock.
XOUT1	O	Output pin for main-oscillator. Connected to 3.58 MHz or 400 KHz crystal or RC to generate system clock.
RA0-RA3	I/O	Input/Output port. Input/output mode specified by port mode 1 register (PM1).
RB0-RB3	I/O	Input/Output port. Input/output mode specified by port mode 2 register (PM2).
RC0-RC3	I	4-bit port for input only. Each pin has an independent interrupt capability.
RD0-RD3	I/O	Input/Output port. Input/output mode specified by port mode 5 register (PM5).
RE0-RE3	O	Output port only. With high sink current capacity for the LED application.
MFP	O	Output pin only. This pin can output modulating or nonmodulating frequency, or Timer 1 specified frequency. It can be selected by bit 0 of BUZCR (BUZCR.0).
DTMF	O	This pin can output dual-tone multifrequency signal for dialling.
$\overline{\text{RES}}$	I	System reset pin with pull-high resistor.
SEG0-SEG31	O	LCD segment output pins.
COM0- COM3	O	LCD common signal output pins. The LCD alternating frequency can be selected by code option.
DH1, DH2	I	Connection terminals for voltage doubler (halver) capacitor.
VDD1 VDD2	I	Positive (+) supply voltage terminal. Refer to Functional Description.
VDD	I	Positive power supply (+).
VSS	I	Negative power supply (-).

# Preliminary W742C814



## 4.1 Pad List

\*\* Shrink factor: 1.000000      Date: 19101/05/02      Time: 17:26:00

\*\* Window: (xl = -1345.00, yl = -1295.00), (xh = 1345.00, yh = 1295.00)

\*\* Windows size: width = 2690.00, length = 2590.00

### QFP 80-pin Bonding

PAD NO.	PAD NAME	PIN NAME	X.	Y.
1	RE1	2	-1250.00	1168.70
2	RE2	3	-1250.00	1038.10
3	RE3	4	-1250.00	907.50
4	Vss	5	-1250.00	776.90
5	SEG<0>	8	-1250.00	639.70
6	SEG<1>	9	-1250.00	509.10
7	SEG<2>	10	-1250.00	378.50
8	SEG<3>	11	-1250.00	247.90
9	SEG<4>	12	-1250.00	117.30
10	SEG<5>	13	-1250.00	-13.30
11	SEG<6>	14	-1250.00	-143.90
12	SEG<7>	15	-1250.00	-274.50
13	SEG<8>	16	-1250.00	-405.10
14	SEG<9>	17	-1250.00	-535.70
15	SEG<10>	18	-1250.00	-666.30
16	SEG<11>	19	-1250.00	-796.90
17	SEG<12>	20	-1250.00	-927.50
18	SEG<13>	21	-1250.00	-1058.10
19	SEG<14>	22	-1250.00	-1188.70
20	SEG<15>	25	-975.00	-1200.00
21	SEG<16>	26	-845.00	-1200.00
22	SEG<17>	27	-715.00	-1200.00
23	SEG<18>	28	-585.00	-1200.00
24	SEG<19>	29	-455.00	-1200.00
25	SEG<20>	30	-325.00	-1200.00
26	SEG<21>	31	-195.00	-1200.00
27	SEG<22>	32	-65.00	-1200.00
28	SEG<23>	33	65.00	-1200.00
29	SEG<24>	34	195.00	-1200.00
30	SEG<25>	35	325.00	-1200.00
31	SEG<26>	36	455.00	-1200.00
32	SEG<27>	37	585.00	-1200.00
33	SEG<28>	38	715.00	-1200.00

# Preliminary W742C814



QFP 80-pin Bonding, continued

PAD NO.	PAD NAME	PIN NAME	X.	Y.
34	SEG<29>	39	845.00	-1200.00
35	SEG<30>	40	975.00	-1200.00
36	SEG<31>	41	1250.00	-1188.70
37	COM<3>	42	1250.00	-1054.40
38	COM<2>	43	1250.00	-913.60
39	COM<1>	44	1250.00	-772.80
40	COM<0>	45	1250.00	-632.00
41	VDD2	46	1250.00	-474.80
42	VDD1	47	1250.00	-330.15
43	DH2	48	1250.00	-179.98
44	DH1	49	1250.00	-49.98
45	XOUT2	52	1250.00	80.03
46	XIN2	53	1250.00	210.03
47	VDD	55	1250.00	340.03
48	XOUT1	57	1250.00	486.93
49	XIN1	58	1250.00	628.13
50	DTMF	59	1250.00	778.83
51	RES	60	1250.00	908.83
52	MFP	62	1250.00	1038.83
53	RA0	63	1250.00	1168.83
54	RA1	65	975.00	1180.00
55	RA2	66	845.00	1180.00
56	RA3	67	715.00	1180.00
57	RB0	68	585.00	1180.00
58	RB1	69	455.00	1180.00
59	RB2	70	325.00	1180.00
60	RB3	71	195.00	1180.00
61	RC0	72	65.00	1180.00
62	RC1	73	-65.00	1180.00
63	RC2	74	-195.00	1180.00
64	RC3	75	-325.00	1180.00
65	RD0	76	-455.00	1180.00
66	RD1	77	-585.00	1180.00
67	RD2	78	-715.00	1180.00
68	RD3	79	-845.00	1180.00
69	RE0	80	-975.00	1180.00

5. BLOCK DIAGRAM

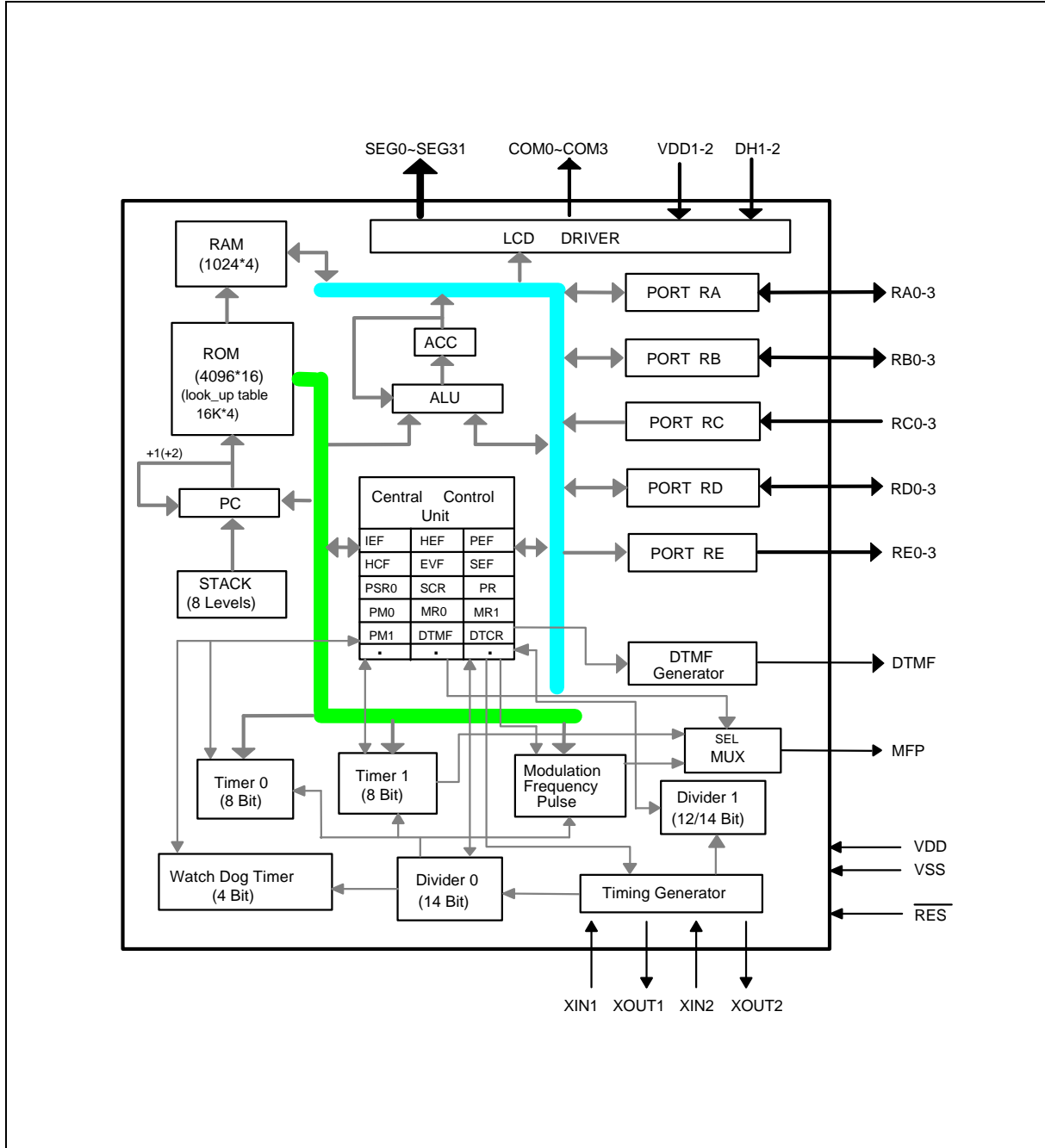





## 6. FUNCTIONAL DESCRIPTION

### 6.1 Program Counter (PC)

Organized as an 14-bit binary counter (PC0 to PC13), the program counter generates the addresses of the  $4096 \times 16$  on-chip ROM containing the program instruction words. Before the jump or subroutine call instructions are to be executed, the destination ROM page must be determined firstly. The confirmation of the ROM page can be done by executing the MOV ROMPR, #I or MOV ROMPR, R instruction. When the interrupt or initial reset conditions are to be executed, the corresponding address will be loaded into the program counter directly. The format used is shown below.

**Table 1 Vector address and interrupt priority**

ITEM	ADDRESS	INTERRUPT PRIORITY
Initial Reset	0000H	-
INT 0 (Divider0)	0004H	1 <sup>st</sup>
INT 1 (Timer 0)	0008H	2 <sup>nd</sup>
INT 2 (Port RC)	000CH	3 <sup>rd</sup>
INT 3 (Divider1)	0014H	4 <sup>th</sup>
INT 4 (Timer 1)	0020H	5 <sup>th</sup>
JP Instruction	XXXXH	-
Subroutine Call	XXXXH	-

### 6.2 Stack Register (STACK)

The stack register is organized as 42 bits x 8 levels (first-in, last-out). When either a call subroutine or an interrupt is executed, the program counter will be pushed onto the stack register automatically. At the end of a call subroutine or an interrupt service subroutine, the RTN instruction must be executed to pop the contents of the stack register into the program counter. (Refer to



Table 8) When the stack register is pushed over the eight levels, the contents of the first level will be lost. In other words, the stack register is always eight levels deep.

## 6.3 Program Memory (ROM)

The read-only memory (ROM) is used to store program codes; and the look-up table is arranged as 16384 x 4 bits. The program ROM is divided into two pages; the size of each page is 2048 x 16 bits. So the total ROM size is 4096 x 16 bits. Before the jump or subroutine call instructions are to be executed, the destination ROM page must be determined firstly. The ROM page can be selected by executing the MOV ROMPR,#I or MOV ROMPR, R instruction. But the branch decision instructions (e.g. JB0, SKB0, JZ, JC, ...) must jump to the same ROM page which the branch decision instructions are in. The whole ROM can store both instruction codes and the look-up table. Each look-up table element is composed of 4 bits, so the look-up table can be addressed up to 16384 elements. Instruction MOVC R is used to read the look-up table content and transfer table data to the RAM. But before reading the addressed look-up table content, the content of the look-up table pointer (TAB) must be determined firstly. The address of the look-up table element is allocated by the content of TAB. The MOV TAB0 (TAB1, TAB2, TAB3), R instructions are used to allocate the address of the wanted look-up table element. The TAB0 register stores the LSB 4 bits of the look-up table address. The organization of the program memory is shown in Figure 6-1.

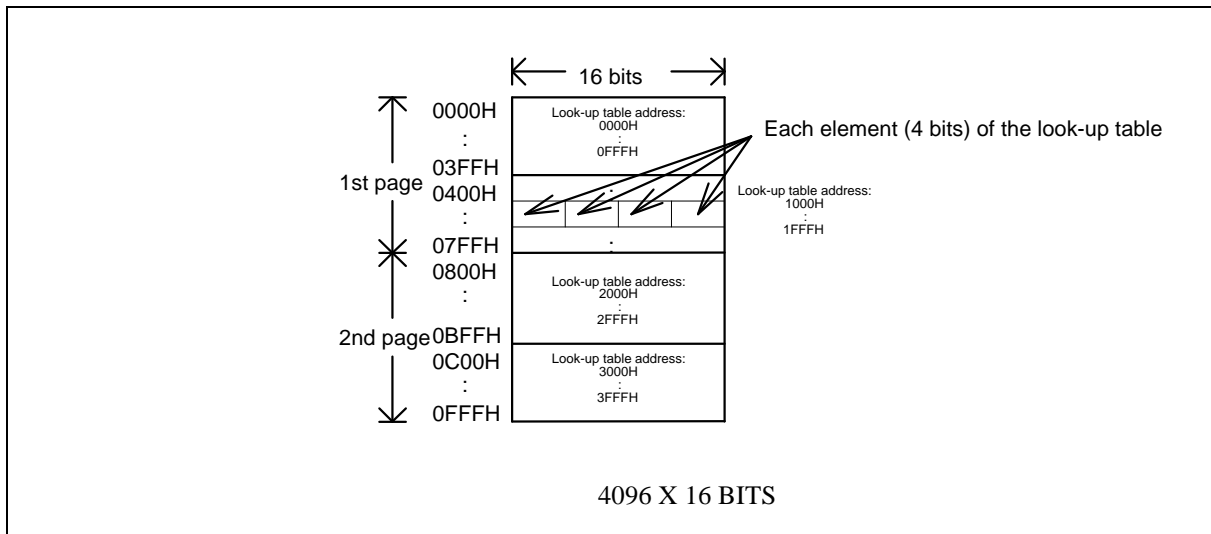
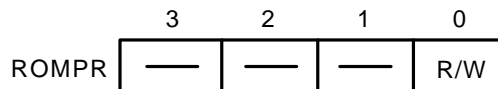

Figure 6-1 Program Memory Organization

### 6.3.1 ROM Page Register (ROMPR)

The ROM page register is organized as a 4-bit binary register. The bit descriptions are as follows:



Note: R/W means read/write available.



Bit 3, Bit 2, Bit 1 is reserved.

Bit 0 ROM page preselect bits:

- 0 = ROM page 0 (0000H - 07FFH)
- 1 = ROM page 1 (0800H - 0FFFH)

## 6.4 Data Memory (RAM)

### 6.4.1 Architecture

The static data memory (RAM) used to store data is arranged as 1024 × 4 bits. The data RAM is divided into eight banks; each bank has 128 × 4 bits. Executing the MOV DBKR,WR or MOV DBKR,#I instruction can determine which data bank is used. The data memory can be addressed directly or indirectly. But the data bank must be confirmed firstly; and the page in the data bank will be done in the indirect addressing mode, too. In indirect addressing mode, each data bank will be divided into eight pages. Before the data memory is addressed indirectly, the page which the data memory is in must be confirmed. The organization of the data memory is shown in Figure 6-2.

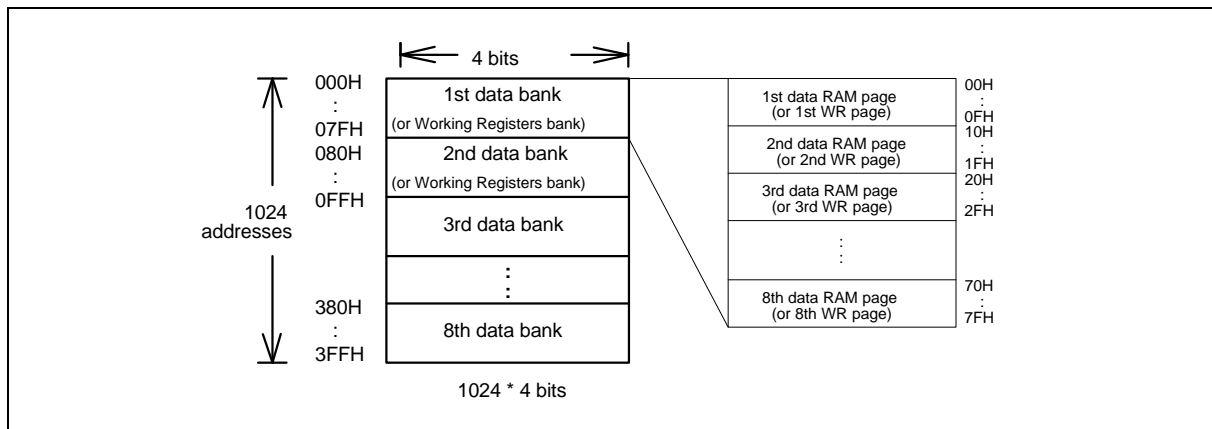

Figure 6-2 Data Memory Organization

The 1st and 2nd data bank (00H to 7FH & 80H to FFH) in the data memory can also be used as the working registers (WR). It is also divided into sixteen pages. Each page contains 16 working registers. When one page is used as WR, the others can be used as the normal data memory. The WR page can be switched by executing the MOV WRP,R or MOV WRP,#I instruction. The data memory cannot operate directly with immediate data, but the WR can do. The relationship between data memory locations and the page register (PAGE) in indirect addressing mode is described in the next subsection.

### 6.4.2 Page Register (PAGE)

The page register is organized as a 4-bit binary register. The bit descriptions are as follows:

	3	2	1	0
PAGE	—	R/W	R/W	R/W

Note: R/W means read/write available.



Bit 3 is reserved.

Bit 2, Bit 1, Bit 0 Indirect addressing mode pre-select bits:

- 000 = Page 0 (00H - 0FH)
- 001 = Page 1 (10H - 1FH)
- 010 = Page 2 (20H - 2FH)
- 011 = Page 3 (30H - 3FH)
- 100 = Page 4 (40H - 4FH)
- 101 = Page 5 (50H - 5FH)
- 110 = Page 6 (60H - 6FH)
- 111 = Page 7 (70H - 7FH)

### 6.4.3 WR Page Register (WRP)

The WR page register is organized as a 4-bit binary register. The bit descriptions are as follows:

	3	2	1	0
WRP	R/W	R/W	R/W	R/W

Note: R/W means read/write available.

Bit 3, Bit 2, Bit 1, Bit 0 Working registers page preselect bits:

- 0000 = WR Page 0 (00H - 0FH)
- 0001 = WR Page 1 (10H - 1FH)
- 0010 = WR Page 2 (20H - 2FH)
- 0011 = WR Page 3 (30H - 3FH)
- 0100 = WR Page 4 (40H - 4FH)
- 0101 = WR Page 5 (50H - 5FH)
- 0110 = WR Page 6 (60H - 6FH)
- 0111 = WR Page 7 (70H - 7FH)
- 1000 = WR Page 8 (80H - 8FH)
- 1001 = WR Page 9 (90H - 9FH)
- 1010 = WR Page A (A0H - AFH)
- 1011 = WR Page B (B0H - BFH)
- 1100 = WR Page C (C0H - CFH)
- 1101 = WR Page D (D0H - DFH)
- 1110 = WR Page E (E0H - EFH)
- 1111 = WR Page F (F0H - FFH)

### 6.4.4 Data Bank Register (DBKR)

The data bank register is organized as a 4-bit binary register. The bit descriptions are as follows:

	3	2	1	0
DBKR	—	R/W	R/W	R/W

Note: R/W means read/write available.



Bit 3 is reserved

Bit 2, Bit 1, Bit 0 Data memory bank preselect bits:

- 000 = Data bank 0 (000H - 07FH)
- 001 = Data bank 1 (080H - 0FFH)
- 010 = Data bank 2 (100H - 17FH)
- 011 = Data bank 3 (180H - 1FFH)
- 100 = Data bank 4 (200H - 27FH)
- 101 = Data bank 5 (280H - 2FFH)
- 110 = Data bank 6 (300H - 37FH)
- 111 = Data bank 7 (380H - 3FFH)

## 6.5 Accumulator (ACC)

The accumulator (ACC) is a 4-bit register used to hold results from the ALU and transfer data between the memory, I/O ports, and registers.

## 6.6 Arithmetic and Logic Unit (ALU)

This is a circuit which performs arithmetic and logic operations. The ALU provides the following functions:

- Logic operations: ANL, XRL, ORL
- Branch decisions: JB0, JB1, JB2, JB3, JNZ, JZ, JC, JNC, DSKZ, DSKNZ, SKB0, SKB1, SKB2, SKB3
- Shift operations: SHRC, RRC, SHLC, RLC
- Binary additions/subtractions: ADC, SBC, ADD, SUB, ADU, DEC, INC

After any of the above instructions are executed, the status of the carry flag (CF) and zero flag (ZF) is stored in the internal registers. CF can be read out by executing MOV R, CF.

## 6.7 Main-Oscillator

The W742C814 provides a crystal or RC oscillation circuit to generate the system clock through external connections. If a crystal oscillator is used, The 3.58 MHz or 400KHz crystal must be connected to XIN1 and XOUT1, and a capacitor must be connected to XIN1 and VSS if an accurate frequency is needed.

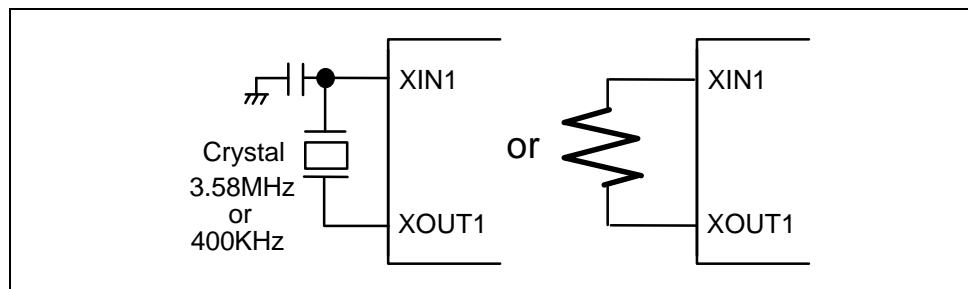

Figure 6-3 System Clock Oscillator Configuration



If a RC oscillator is used, The typical frequency is 2 MHz.

## 6.8 Sub-Oscillator

The sub-oscillator is used in dual-clock operation mode. In the sub-oscillator application, just only the 32768 Hz crystal could be connected to XIN2 and XOUT2, and it would not be oscillated in STOP mode.

## 6.9 Dividers

Each divider is organized as a 14-bit binary up-counter designed to generate periodic interrupts. When the main oscillator starts action, the Divider0 is incremented by each clock (FOSC). When an overflow occurs, the Divider0 event flag is set to 1 (EVF.0 = 1). Then, if the Divider0 interrupt enable flag has been set (IEF.0 = 1), the interrupt is executed, while if the hold release enable flag has been set (HEF.0 = 1), the hold state is terminated. And the last 4-stage of the Divider0 can be reset by executing CLR DIVR0 instruction.

If the sub-oscillator starts action, the Divider1 is incremented by each clock (Fs or Fosc/128). When an overflow occurs, the Divider1 event flag is set to 1 (EVF.4 = 1). Then, if the Divider1 interrupt enable flag has been set (IEF.4 = 1), the interrupt is executed, while if the hold release enable flag has been set (HEF.4 = 1), the hold state is terminated. And the last 4-stage of the Divider1 can be reset by executing CLR DIVR1 instruction. Same as EVF.0, the EVF.4 is set to 1 periodically. But there are two period time (125 mS & 500 mS) that can be selected by setting the SCR.3 bit. When SCR.3 = 0 (default), the 500 mS period time is selected; SCR.3 = 1, the 125 mS period time is selected.

## 6.10 Dual-clock operation

This operation mode is selected by option code. In the dual-clock mode, the clock source of the LCD frequency selector should be the sub-oscillator clock (32768 Hz) only. But in the signal-clock mode, the clock source of the LCD frequency selector will be Fm/128 (Fm: main oscillator clock, See figure 6-4).

*So before the STOP instruction is executing, the LCD must be turned off in the signal-clock mode or dual-clock mode.*

In this dual-clock mode, the normal operation is performed by generating the system clock from the main-oscillator clock (Fm). As required, the slow operation can be performed by generating the system clock from the sub-oscillator clock (Fs). The exchange of the normal operation and the slow operation is performed by resetting or setting the bit 0 of the System clock Control Register (SCR). If the SCR.0 is reset to 0, the clock source of the system clock generator is main-oscillator clock; if the SCR.0 is set to 1, the clock source of the system clock generator is sub-oscillator clock. In the dual-clock mode, the main-oscillator can stop oscillating when the STOP instruction is executing or the SCR.1 is set to 1.

When the SCR is set or reset, we must care the following cases:

1. X000B → X011B: we should not exchange the FOSC from Fm into Fs and disable Fm simultaneously. We could first exchange the FOSC from Fm into Fs, then disable the main-oscillator. So it should be X000B→X001B→X011B.
2. X011B → X000B: we should not enable Fm and exchange the FOSC from Fs into Fm simultaneously. We could first enable the main-oscillator; the 2nd step is calling a delay subroutine to wait the main-oscillator oscillating stably; then exchange the FOSC from Fs into Fm is the last step. So it should be X011B→X001B→delay the Fm oscillating stably time→X000B. The suggestion of the Fm oscillating stably time is 3.5 mS for 455 KHz and 0.8 mS for 4 MHz.

We must remember that the X010B state is inhibitive, because it will induce the system shutdown. The organization of the dual-clock operation mode is shown in Figure 6-4.

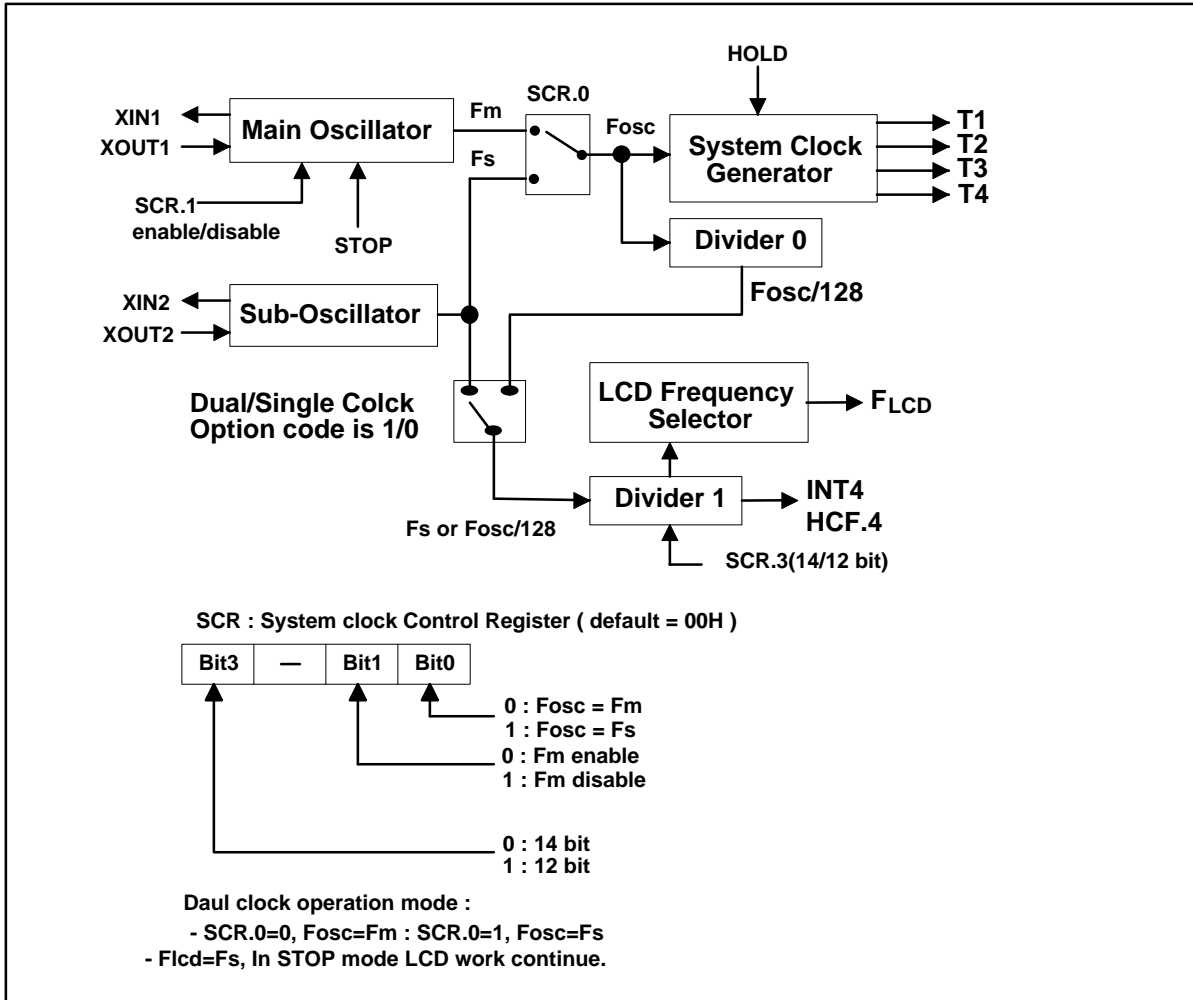

Figure 6-4 Organization of the dual-clock operation mode

## 6.11 WatchDog Timer (WDT) and WatchDog Timer Register (WDTR)

The watchdog timer (WDT) is organized as a 4-bit up counter designed to prevent the program from unknown errors. When the corresponding option code bit of the WDT set to 1, the WDT is enabled, and if the WDT overflows, the chip will be reset. At initial reset, the input clock of the WDT is  $F_{osc}/2048$ . The input clock of the WDT can be switched to  $F_{osc}/16384$  (or  $F_{osc}/2048$ ) by setting  $WDTR.3$  to 1. The contents of the WDT can be reset by the instruction CLR WDT. In normal operation, the application program must reset WDT before it overflows. A WDT overflow indicates that operation is not under control and the chip will be reset. The WDT overflow period is 1 S when the sub-system clock ( $F_s$ ) is 32 KHz and WDT clock input is  $F_s/2048$ . When the corresponding option code bit of the WDT set to 0, the WDT function is disabled. The organization of the Divider0 and watchdog timer is shown in Figure 6-5.

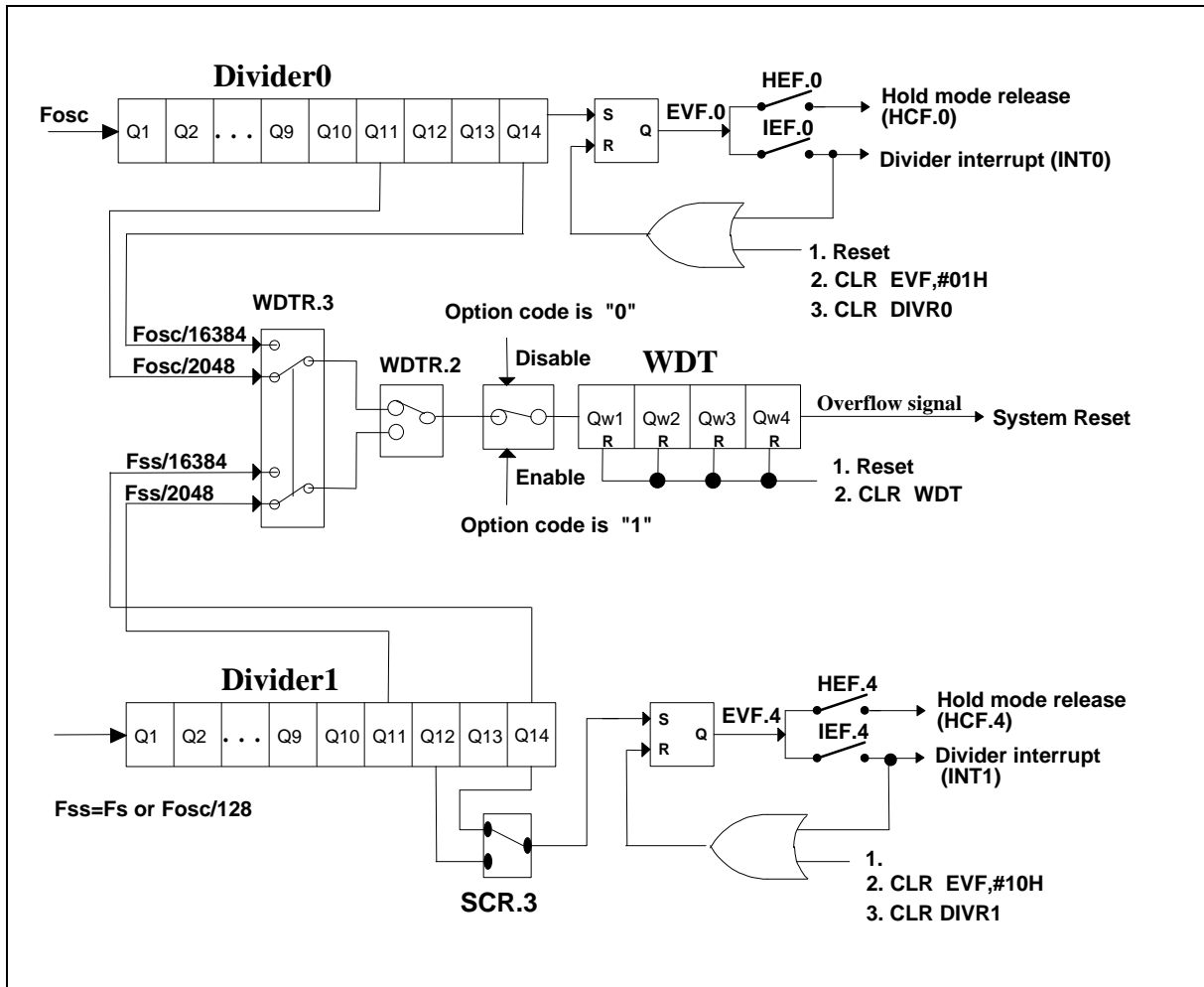

Figure 6-5 Organization of Divider0, Divider1 and WatchDog Timer

	3	2	1	0
WDTR	R/W	R/W	R/W	R

Note: R/W means read/write available, R means read only.

Power On reset default is: 0000

- Bit 3 = 0 Fosc/2048(Select Divider0) or Fss/2048(Select Divider1) as the WDT source.
- = 1 Fosc/16384(Select Divider0) or Fss/16384(Select Divider1) as the WDT source.
- Bit 2 = 0 Select Divider0.
- = 1 Select Divider1.
- Bit 1 = 0 Refer to Table 2.
- = 1 Refer to Table 2.
- Bit 0 = 0 No time out.
- = 1 Time out.



# Preliminary W742C814



WDTR.0 will be set to one when WDT time out and can be reset to zero by:  
Power On Reset, RESET pin, CLR WDT

**Table 2 The bit 1 of WatchDog Timer Register (WDTR) reset item**

RESET ITEM	WDTR.1 = 1	WDTR.1 = 0
Program Counter (PC)	0000H	0000H
Stack Pointer (SP)	-	Reset
ROMPR, PAGE, DBKR, WRP, ACC, CF, ZF, SCR Registers	-	Reset
IEF, HEF, SEF, HCF, PEF, EVF flags	IEF = Reset	Reset
DIV0, DIV1	-	Reset
TM0, TM1, MR0, MR1 Registers	-	Reset
Timer 0 Input Clock	-	FOSC/4
Timer 1 Input Clock	-	FOSC
MFP Output	-	Low
PM0 Register	-	Reset
PM1, PM2, PM5 Registers	-	Set (1111B)
PSR0 Register	-	Reset
Input/Output Ports RA, RB, RD	-	Input mode
Output Ports RE	-	High
RA, RB Ports Output Type	-	CMOS type
RC Port Pull-high Resistors	-	Disable
Input Clock of the Watchdog Timer	-	FOSC/2048
DTMF Output	-	Hi-Z
BUZCR Register	-	Reset
FLCD	-	Q5 to Q9 Reset
LCD Display	-	OFF
LCDR	-	Reset
Segment Output Mode	-	LCD drive output

-: keep the status

Note: SCR.2 is reserved



## 6.12 Timer/Counter

### 6.12.1 Timer 0 (TM0)

Timer 0 (TM0) is a programmable 8-bit binary down-counter. The specified value can be loaded into TM0 by executing the MOV TM0L(TM0H),R instructions. When the MOV TM0L(TM0H),R instructions are executed, it will stop the TM0 down-counting (if the TM0 is down-counting) and reset the MR0.3 to 0, and the specified value can be loaded into TM0. Then we can set MR0.3 to 1, that will cause the event flag 1 (EVF.1) is reset and the TM0 starts to count. When it decreases and underflow to FFH, Timer 0 stops operating and generates an underflow (EVF.1 = 1). Then, if the Timer 0 interrupt enable flag has been set (IEF.1 = 1), the interrupt is executed, while if the hold release enable flag 1 has been set (HEF.1 = 1), the hold state is terminated. The Timer 0 clock input can be set as FOSC/1024 or FOSC/4 by setting MR0.0 to 1 or resetting MR0.0 to 0. The default timer value is FOSC/4. The organization of Timer 0 is shown in Figure 6-6.

If the Timer 0 clock input is FOSC/4:

$$\text{Desired Timer 0 interval} = (\text{preset value} + 1) \times 4 \times 1/\text{Fosc}$$

If the Timer 0 clock input is FOSC/1024:

$$\text{Desired Timer 0 interval} = (\text{preset value} + 1) \times 1024 \times 1/\text{Fosc}$$

Preset value: Decimal number of Timer 0 preset value

Fosc: Clock oscillation frequency

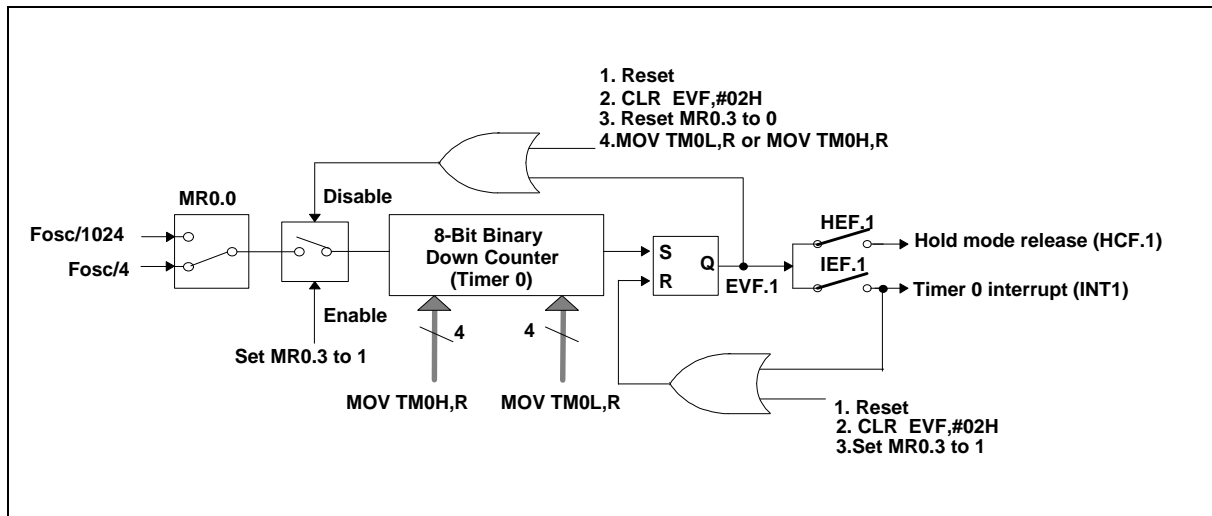

Figure 6-6 Organization of Timer 0

### 6.12.2 Timer 1 (TM1)

Timer 1 (TM1) is also a programmable 8-bit binary down counter, as shown in Figure 6-7. Timer 1 can be used as to output an arbitrary frequency to the MFP pin. The input clock of Timer 1 can be one of three sources: FOSC/64, FOSC, or Fs. The source can be selected by setting bit 0 and bit 1 of mode register 1 (MR1). At initial reset, the Timer 1 clock input is FOSC. When the MOV TM1L, R or MOV TM1H,R instruction is executed, the specified data are loaded into the auto-reload buffer; but the TM1



down-counting will keep going on. If the bit 3 of MR1 is set (MR1.3 = 1), the content of the auto-reload buffer will be loaded into the TM1 down counter, and Timer 1 starts to down count, and the event flag 7 is reset (EVF.7 = 0). When the timer decreases and underflow to FFH, it will generate an underflow (EVF.7 = 1) and be auto-reloaded with the specified data, after which it will continue to count down. Then, if interrupt enable flag 7 has been set to 1 (IEF.7 = 1), an interrupt is executed; if hold mode release enable flag 7 is set to 1 (HEF.7 = 1), the hold state is terminated. The specified frequency of Timer 1 can be delivered to the MFP output pin by programming bit 2 of MR1. Bit 3 of MR1 can be used to make Timer 1 stop or start counting.

In a case where Timer 1 clock input is FT:

$$\text{Desired Timer 1 interval} = (\text{preset value} + 1) / F_T$$

$$\text{Desired frequency for MFP output pin} = F_T \div (\text{preset value} + 1) \div 2 \text{ (Hz)}$$

Preset value: Decimal number of Timer 1 preset value

FOSC: Clock oscillation frequency

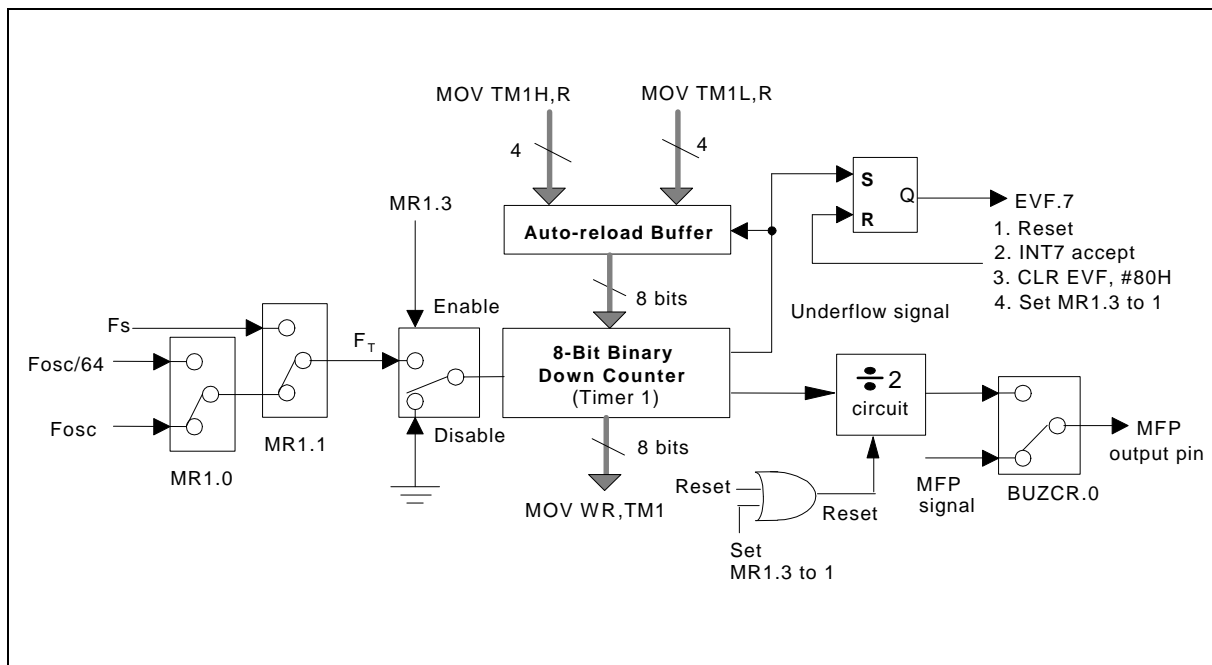

Figure 6-7 Organization of Timer 1

For example, when FT equals 32768 Hz, depending on the preset value of TM1, the MFP pin will output a single tone signal in the tone frequency range from 64 Hz to 16384 Hz. The relation between the tone frequency and the preset value of TM1 is shown in the table below.

MOV WR, TM1 can read back the content of TM1, It will save the TM1 MSB to WR and the TM1 LSB to ACC.



**Table 3 The relation between the tone frequency and the present value of TM1**

		3rd octave			4th octave			5th octave		
		Tone frequency	TM1 preset value & MFP frequency		Tone frequency	TM1 preset value & MFP frequency		Tone frequency	TM1 preset value & MFP frequency	
<b>TONE</b>	<b>C</b>	130.81	7CH	131.07	261.63	3EH	260.06	523.25	1EH	528.51
	<b>C #</b>	138.59	75H	138.84	277.18	3AH	277.69	554.37	1CH	564.96
	<b>D</b>	146.83	6FH	146.28	293.66	37H	292.57	587.33	1BH	585.14
	<b>D #</b>	155.56	68H	156.03	311.13	34H	309.13	622.25	19H	630.15
	<b>E</b>	164.81	62H	165.49	329.63	31H	327.68	659.26	18H	655.36
	<b>F</b>	174.61	5DH	174.30	349.23	2EH	372.36	698.46	16H	712.34
	<b>F #</b>	185.00	58H	184.09	369.99	2BH	390.09	739.99	15H	744.72
	<b>G</b>	196.00	53H	195.04	392.00	29H	420.10	783.99	14H	780.19
	<b>G #</b>	207.65	4EH	207.39	415.30	26H	443.81	830.61	13H	819.20
	<b>A</b>	220.00	49H	221.40	440.00	24H	442.81	880.00	12H	862.84
	<b>A #</b>	233.08	45H	234.05	466.16	22H	468.11	932.23	11H	910.22
	<b>B</b>	246.94	41H	248.24	493.88	20H	496.48	987.77	10H	963.76

Note: Central tone is A4 (440 Hz).

### 6.12.3 Mode Register 0 (MR0)

Mode Register 0 is organized as a 4-bit binary register (MR0.0 to MR0.3). MR0 can be used to control the operation of Timer 0. The bit descriptions are as follows:

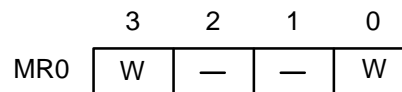

Note: W means write only.

Bit 0 = 0 The fundamental frequency of Timer 0 is  $F_{OSC}/4$ .

= 1 The fundamental frequency of Timer 0 is  $F_{OSC}/1024$ .

Bit 1 & Bit 2 are reserved

Bit 3 = 0 Timer 0 stops down-counting.

= 1 Timer 0 starts down-counting.

### 6.12.4 Mode Register 1 (MR1) & MFP Control Pin (BUZCR)

Mode Register 1 is organized as a 4-bit binary register (MR1.0 to MR1.3). MR1 can be used to control the operation of Timer 1. The bit descriptions are as follows:

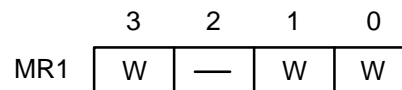

Note: W means write only.



- Bit 0 = 0 The internal fundamental frequency of Timer 1 is FOSC.  
= 1 The internal fundamental frequency of Timer 1 is FOSC/64.
- Bit 1 = 0 The fundamental frequency source of Timer 1 is the internal clock.  
= 1 The fundamental frequency source of Timer 1 is the sub-oscillator frequency Fs (32768 Hz).
- Bit 2 is reserved.
- Bit 3 = 0 Timer 1 stops down-counting.  
= 1 Timer 1 starts down-counting.

MFP control pin is organized as a 4-bit binary register.

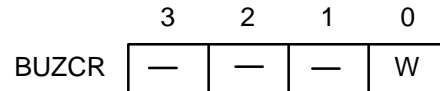

Note: W means write only.

- Bit 0 = 0 The specified waveform of the MFP generator is delivered to the MFP output pin.  
= 1 The specified frequency of Timer 1 is delivered to the MFP output pin.
- Bit 1, Bit 2 & Bit 3 are reserved.

## 6.13 Interrupts

The W742C814 provides four internal interrupt sources (Divider 0, Divider 1, Timer 0, Timer 1) and one external interrupt source (port RC). Vector addresses for each of the interrupts are located in the range of program memory (ROM) addresses 004H to 020H. The flags IEF, PEF, and EVF are used to control the interrupts. When EVF is set to "1" by hardware and the corresponding bits of IEF and PEF have been set by software, an interrupt is generated. When an interrupt occurs, all of the interrupts are inhibited until the EN INT or MOV IEF,#I instruction is invoked. The interrupts can also be disabled by executing the DIS INT instruction. When an interrupt is generated in hold mode, the hold mode will be released momentarily and interrupt subroutine will be executed. After the RTN instruction is executed in an interrupt subroutine, the  $\mu$ C will enter hold mode again. The operation flow chart is shown in Figure 6-9. The control diagram is shown in Figure 6-9.

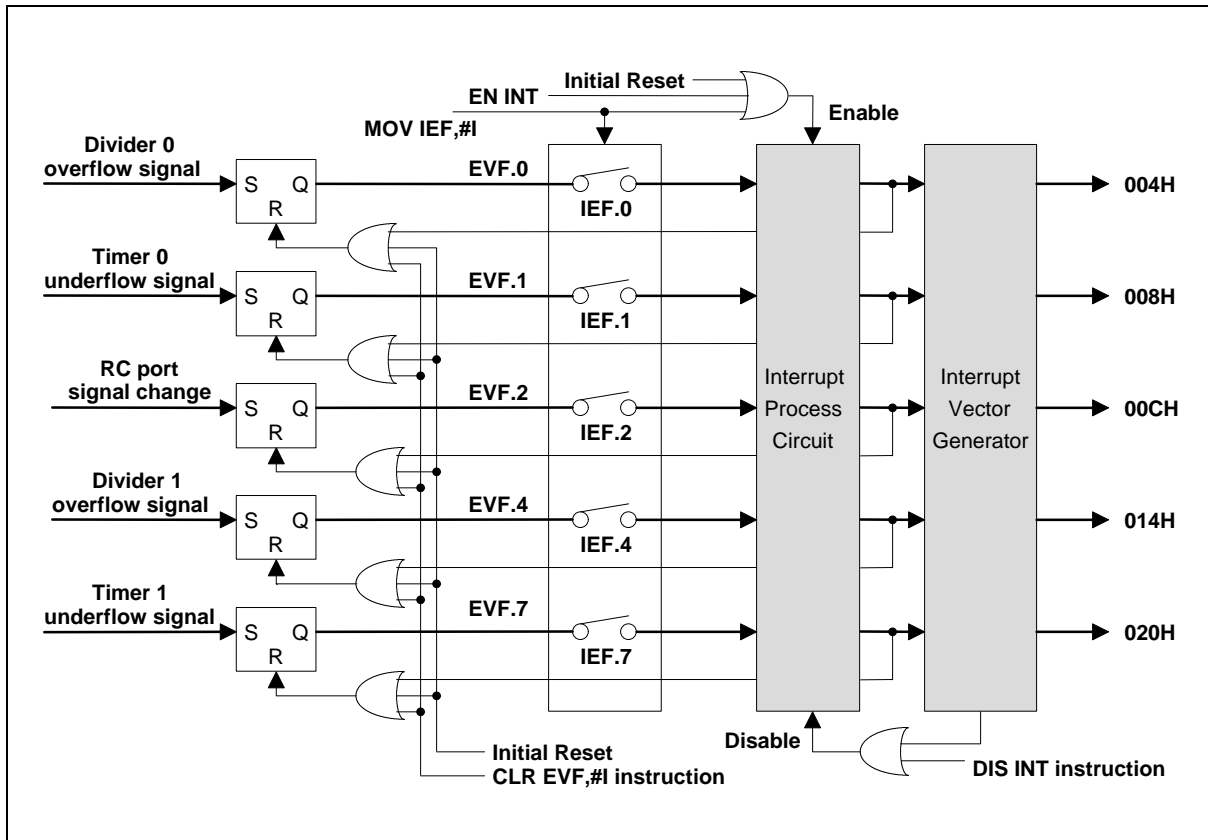

Figure 6-8 Interrupt event control diagram

## 6.14 Stop Mode Operation

In stop mode, all operations of the  $\mu\text{C}$  cease, and the MFP pin is kept to high. The  $\mu\text{C}$  enters stop mode when the STOP instruction is executed and exits stop mode when an external trigger is activated (by a falling signal on the RC). When the designated signal is accepted, the  $\mu\text{C}$  awakens and executes the next instruction. To prevent erroneous execution, the NOP instruction should follow the STOP command. But In the dual-clock slow operation mode, the STOP instruction will also disable the sub-oscillator oscillating; the  $\mu\text{C}$  system will be all cease.

### 6.14.1 Stop Mode Wake-up Enable Flag for RC Port (SEF)

The stop mode wake-up flag for port RC is organized as an 4-bit binary register (SEF.0 to SEF.3). Before port RC may be used to make the device exit the stop mode, the content of the SEF must be set first. The SEF is controlled by the MOV SEF, #I instruction. The bit descriptions are as follows:

	3	2	1	0
SEF	w	w	w	w

Note: W means write only.

SEF.0 = 1 Device will exit stop mode when falling edge signal is applied to pin RC.0

SEF.1 = 1 Device will exit stop mode when falling edge signal is applied to pin RC.1



- SEF.2 = 1     Device will exit stop mode when falling edge signal is applied to pin RC.2
- SEF.3 = 1     Device will exit stop mode when falling edge signal is applied to pin RC.3

## 6.15 Hold Mode Operation

In hold mode, all operations of the  $\mu\text{C}$  cease, except for the operation of the oscillator, Timer, Divider, LCD driver, DTMF generator and MFP generator. The  $\mu\text{C}$  enters hold mode when the HOLD instruction is executed. The hold mode can be released in one of five ways: by the action of timer 0, timer 1, divider 0, divider 1, the RC port. Before the device enters the hold mode, the HEF, PEF, and IEF flags must be set to define the hold mode release conditions. For more details, refer to the instruction-set table and the following flow chart.

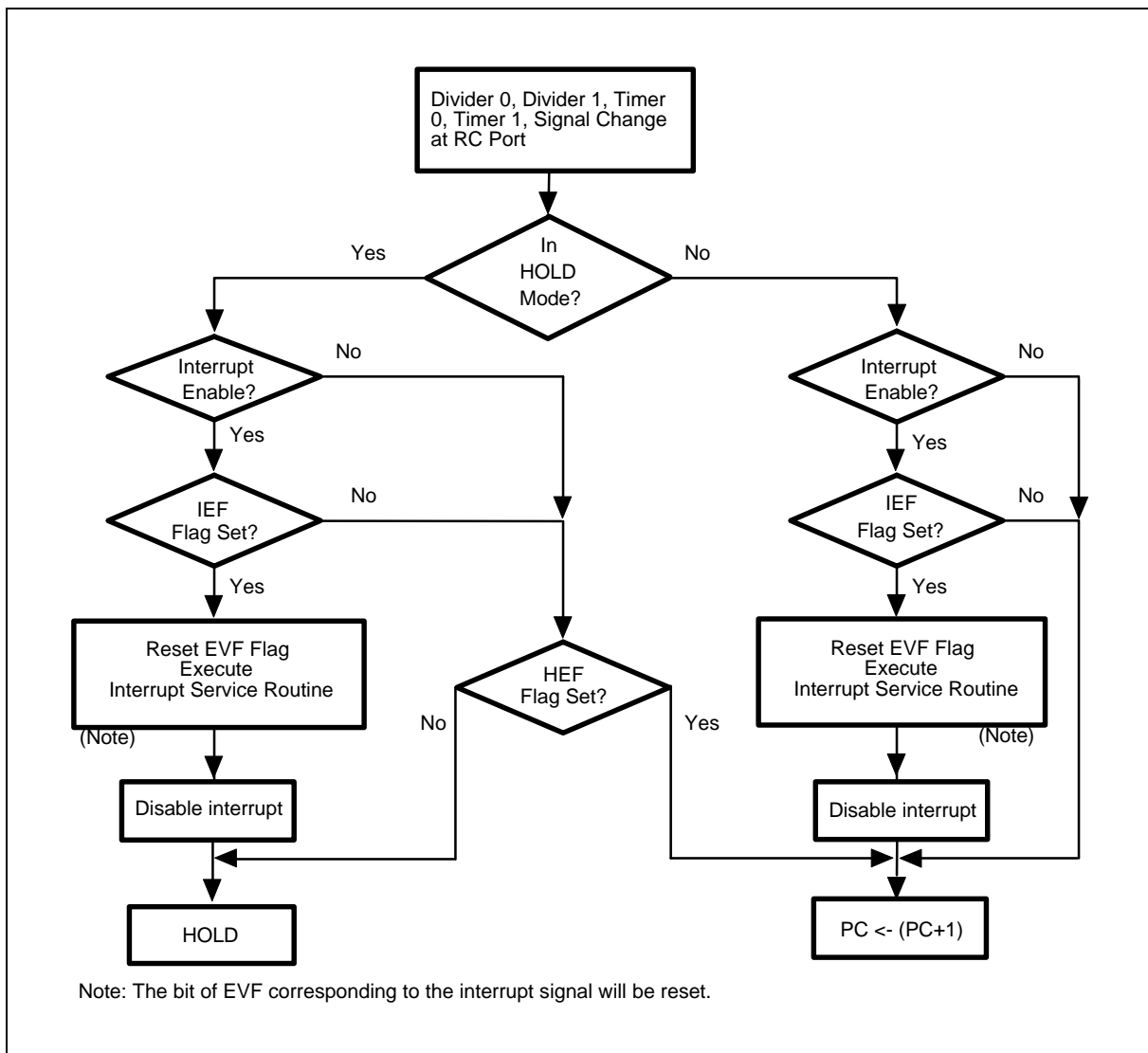

Figure 6-9 Hold Mode and Interrupt Operation Flow Chart



## 6.15.1 Hold Mode Release Enable Flag (HEF)

The hold mode release enable flag is organized as an 8-bit binary register (HEF.0 to HEF.7). The HEF is used to control the hold mode release conditions. It is controlled by the MOV HEF, #I instruction. The bit descriptions are as follows:

	7	6	5	4	3	2	1	0
HEF	w	—	—	w	—	w	w	w

Note: W means write only.

HEF.0 = 1      Overflow from the Divider 0 causes Hold mode to be released.

HEF.1 = 1      Underflow from Timer 0 causes Hold mode to be released.

HEF.2 = 1      Signal change at port RC causes Hold mode to be released.

HEF.3, HEF.5 & HEF.6 are reserved.

HEF.4 = 1      Overflow from the Divider 1 causes Hold mode to be released.

HEF.7 = 1      Underflow from Timer 1 causes Hold mode to be released.

## 6.15.2 Interrupt Enable Flag (IEF)

The interrupt enable flag is organized as a 8-bit binary register (IEF.0 to IEF.7). These bits are used to control the interrupt conditions. It is controlled by the MOV IEF, #I instruction. When one of these interrupts is accepted, the corresponding to the bit of the event flag will be reset, but the other bits are unaffected. In interrupt subroutine, these interrupts will be disable till the instruction MOV IEF, #I or EN INT is executed again. Otherwise, these interrupts can be disable by executing DIS INT instruction. The bit descriptions are as follows:

	7	6	5	4	3	2	1	0
IEF	w	—	—	w	—	w	w	w

Note: W means write only.

IEF.0 = 1      Interrupt 0 is accepted by overflow from the Divider 0.

IEF.1 = 1      Interrupt 1 is accepted by underflow from the Timer 0.

IEF.2 = 1      Interrupt 2 is accepted by a signal change at port RC.

IEF.3, IEF.5 & IEF.6 are reserved.

IEF.4 = 1      Interrupt 4 is accepted by overflow from the Divider 1.

IEF.7 = 1      Interrupt 7 is accepted by underflow from Timer 1.

## 6.15.3 Port Enable Flag (PEF)

The port enable flag is organized as 4-bit binary register (PEF.0 to PEF.3). Before port RC may be used to release the hold mode or preform interrupt function, the content of the PEF must be set first. The PEF is controlled by the MOV PEF, #I instruction. The bit descriptions are as follows:

	3	2	1	0
PEF	w	w	w	w

Note: W means write only.





- PEF.0: Enable/disable the signal change at pin RC.0 to release hold mode or perform interrupt.
- PEF.1: Enable/disable the signal change at pin RC.1 to release hold mode or perform interrupt.
- PEF.2: Enable/disable the signal change at pin RC.2 to release hold mode or perform interrupt.
- PEF.3: Enable/disable the signal change at pin RC.3 to release hold mode or perform interrupt.

### 6.15.4 Hold Mode Release Condition Flag (HCF)

The hold mode release condition flag is organized as a 8-bit binary register (HCF.0 to HCF.7). It indicates by which interrupt source the hold mode has been released, and is loaded by hardware. The HCF can be read out by the MOVA R, HCFL and MOVA R, HCFH instructions. When any of the HCF bits is "1," the hold mode will be released and the HOLD instruction is invalid. The HCF can be reset by the CLR EVF or MOV HEF,#I (HEF = 0) instructions. When EVF and HEF have been reset, the corresponding bit of HCF is reset simultaneously. The bit descriptions are as follows:

	7	6	5	4	3	2	1	0
HCF	—	—	R	R	—	R	R	R

Note: R means read only.

- HCF.0 = 1 Hold mode was released by overflow from the divider 0.
- HCF.1 = 1 Hold mode was released by underflow from the timer 0.
- HCF.2 = 1 Hold mode was released by a signal change at port RC.
- HCF.3 is reserved.
- HCF.4 = 1 Hold mode was released by overflow from the divider 1.
- HCF.5 = 1 Hold mode was released by underflow from the timer 1.
- HCF.6 and HCF.7 are reserved.

### 6.15.5 Event Flag (EVF)

The event flag is organized as a 8-bit binary register (EVF.0 to EVF.7). It is set by hardware and reset by CLR EVF,#I instruction or the occurrence of an interrupt. The bit descriptions are as follows:

	7	6	5	4	3	2	1	0
EVF	R	—	—	R	—	R	R	R

Note: R means read only.

- EVF.0 = 1 Overflow from divider 0 occurred.
- EVF.1 = 1 Underflow from timer 0 occurred.
- EVF.2 = 1 Signal change at port RC occurred.
- EVF.3 is reserved.
- EVF.4 = 1 Overflow from divider 1 occurred.
- EVF.5 & EVF.6 are reserved.



EVF.7 = 1 Underflow from Timer 1 occurred.

## 6.16 Reset Function

The W742C814 is reset either by a power-on reset or by using the external  $\overline{\text{RES}}$  pin. The initial state of the W742C814 after the reset function is executed is described below.

**Table 4 The initial state after the reset function is executed**

Program Counter (PC)	000H
WDTR Registers	Reset
BUZCR Registers	Reset
ACC, CF, ZF Registers	Reset
MR0, MR1, PAGE Registers	Reset
PSR0, SCR, TM0, TM1 Registers	Reset
IEF, HEF, HCF, PEF, EVF, SEF Flags	Reset
WRP, DBKR, PAGE Registers	Reset
Timer 0 Input Clock	FOSC/4
Timer 1 Input Clock	FOSC
MFP Output	Low
DTMF Output	Hi-Z
Input/Output Ports RA, RB, RD	Input mode
Output Port RE	High
RA, RB Ports Output Type	CMOS type
RC Ports Pull-high Resistors	Disable
Input Clock of the Watchdog Timer	FOSC/2048
LCD Display	OFF

## 6.17 Input/Output Ports RA, RB & RD

Port RA consists of pins RA.0 to RA.3. Port RB consists of pins RB.0 to RB.3. Port RD consists of pins RD.0 to RD.3. At initial reset, input/output ports RA, RB and RD are all in input mode. When RA, RB are used as output ports, CMOS or NMOS open drain output type can be selected by the PM0 register. But when RD is used as output port, the output type is just fixed to be CMOS output type. Each pin of port RA, RB and RD can be specified as input or output mode independently by the PM1, PM2 and PM5 registers. The MOVA R, RA or MOVA R, RB or MOVA R, RD instructions operate the input functions and the MOV RA, R or MOV RB, R or MOV RD, R operate the output functions. For more details, refer to the instruction table and Figure 6-10 and Figure 6-11.

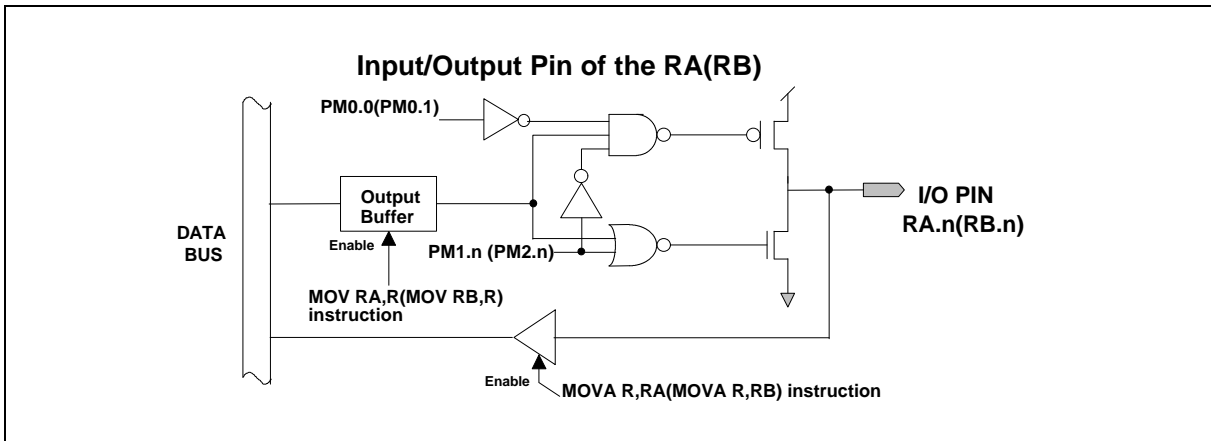

Figure 6-10 Architecture of RA (RB) Input/Output Pins

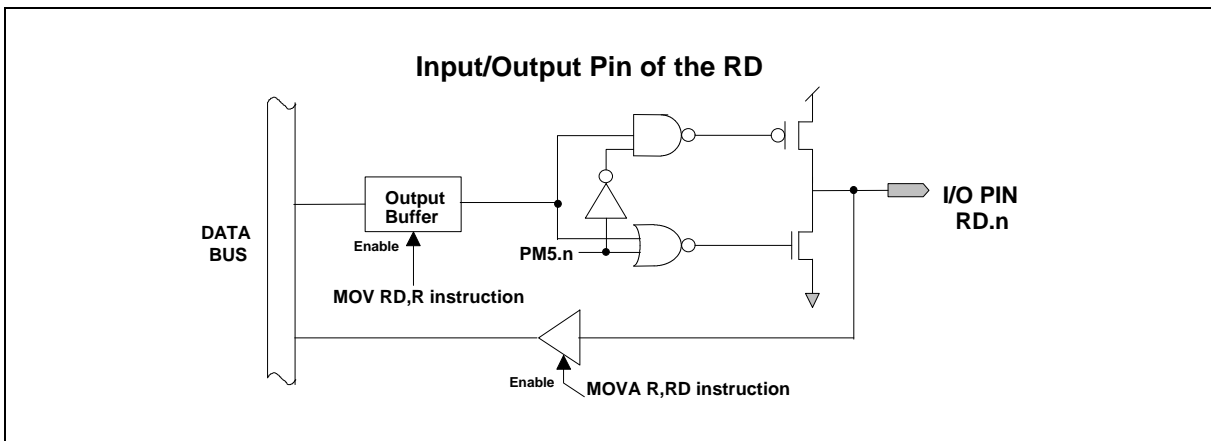

Figure 6-11 Architecture of RD Input/Output pins

### 6.17.1 Port Mode 0 Register (PM0)

The port mode 0 register is organized as 4-bit binary register (PM0.0 to PM0.3). PM0 can be used to determine the structure of the input/output ports; it is controlled by the MOV PM0, #I instruction. The bit descriptions are as follows:

	3	2	1	0
PM0	—	w	w	w

Note: W means write only.

- Bit 0 = 0 RA port is CMOS output type.      Bit 0 = 1 RA port is NMOS open drain output type.
- Bit 1 = 0 RB port is CMOS output type.      Bit 1 = 1 RB port is NMOS open drain output type.
- Bit 2 = 0 RC port pull-high resistor is disabled. Bit 2 = 1 RC port pull-high resistor is enabled.
- Bit 3 is reserved.



## 6.17.2 Port Mode 1 Register (PM1)

The port mode 1 register is organized as 4-bit binary register (PM1.0 to PM1.3). PM1 can be used to control the input/output mode of port RA. PM1 is controlled by the MOV PM1, #I instruction. The bit descriptions are as follows:

	3	2	1	0
PM1	w	w	w	w

Note: W means write only.

Bit 0 = 0      RA.0 works as output pin; Bit 0 = 1      RA.0 works as input pin  
 Bit 1 = 0      RA.1 works as output pin; Bit 1 = 1      RA.1 works as input pin  
 Bit 2 = 0      RA.2 works as output pin; Bit 2 = 1      RA.2 works as input pin  
 Bit 3 = 0      RA.3 works as output pin; Bit 3 = 1      RA.3 works as input pin

At initial reset, port RA is input mode (PM1 = 1111B).

## 6.17.3 Port Mode 2 Register (PM2)

The port mode 2 register is organized as 4-bit binary register (PM2.0 to PM2.3). PM2 can be used to control the input/output mode of port RB. PM2 is controlled by the MOV PM2, #I instruction. The bit descriptions are as follows:

	3	2	1	0
PM2	w	w	w	w

Note: W means write only.

Bit 0 = 0      RB.0 works as output pin; Bit 0 = 1      RB.0 works as input pin  
 Bit 1 = 0      RB.1 works as output pin; Bit 1 = 1      RB.1 works as input pin  
 Bit 2 = 0      RB.2 works as output pin; Bit 2 = 1      RB.2 works as input pin  
 Bit 3 = 0      RB.3 works as output pin; Bit 3 = 1      RB.3 works as input pin

At initial reset, the port RB is input mode (PM2 = 1111B).

## 6.17.4 Port Mode 5 Register (PM5)

The port mode 5 register is organized as 4-bit binary register (PM5.0 to PM5.3). PM5 can be used to control the input/output mode of port RD. PM5 is controlled by the MOV PM5, #I instruction. The bit descriptions are as follows:

	3	2	1	0
PM5	w	w	w	w

Note: W means write only.

Bit 0 = 0      RD.0 works as output pin; Bit 0 = 1      RD.0 works as input pin  
 Bit 1 = 0      RD.1 works as output pin; Bit 1 = 1      RD.1 works as input pin  
 Bit 2 = 0      RD.2 works as output pin; Bit 2 = 1      RD.2 works as input pin  
 Bit 3 = 0      RD.3 works as output pin; Bit 3 = 1      RD.3 works as input pin

At initial reset, the port RD is input mode (PM5 = 1111B).



### 6.18 Input Ports RC

Port RC consists of pins RC.0 to RC.3. Each pin of port RC can be connected to a pull-up resistor, which is controlled by the port mode 0 register (PM0). When the PEF, HEF, and IEF corresponding to the RC port are set, a signal change at the specified pins of port RC will execute the hold mode release or interrupt subroutine. Port status register 0 (PSR0) records the status of ports RC, i.e., any signal changes on the pins that make up the ports. PSR0 can be read out and cleared by the MOV R, PSR0, and CLR PSR0 instructions. In addition, the falling edge signal on the pin of port RC specified by the instruction MOV SEF, #1 will cause the device to exit the stop mode. Refer to Figure 6-12 and the instruction table for more details.

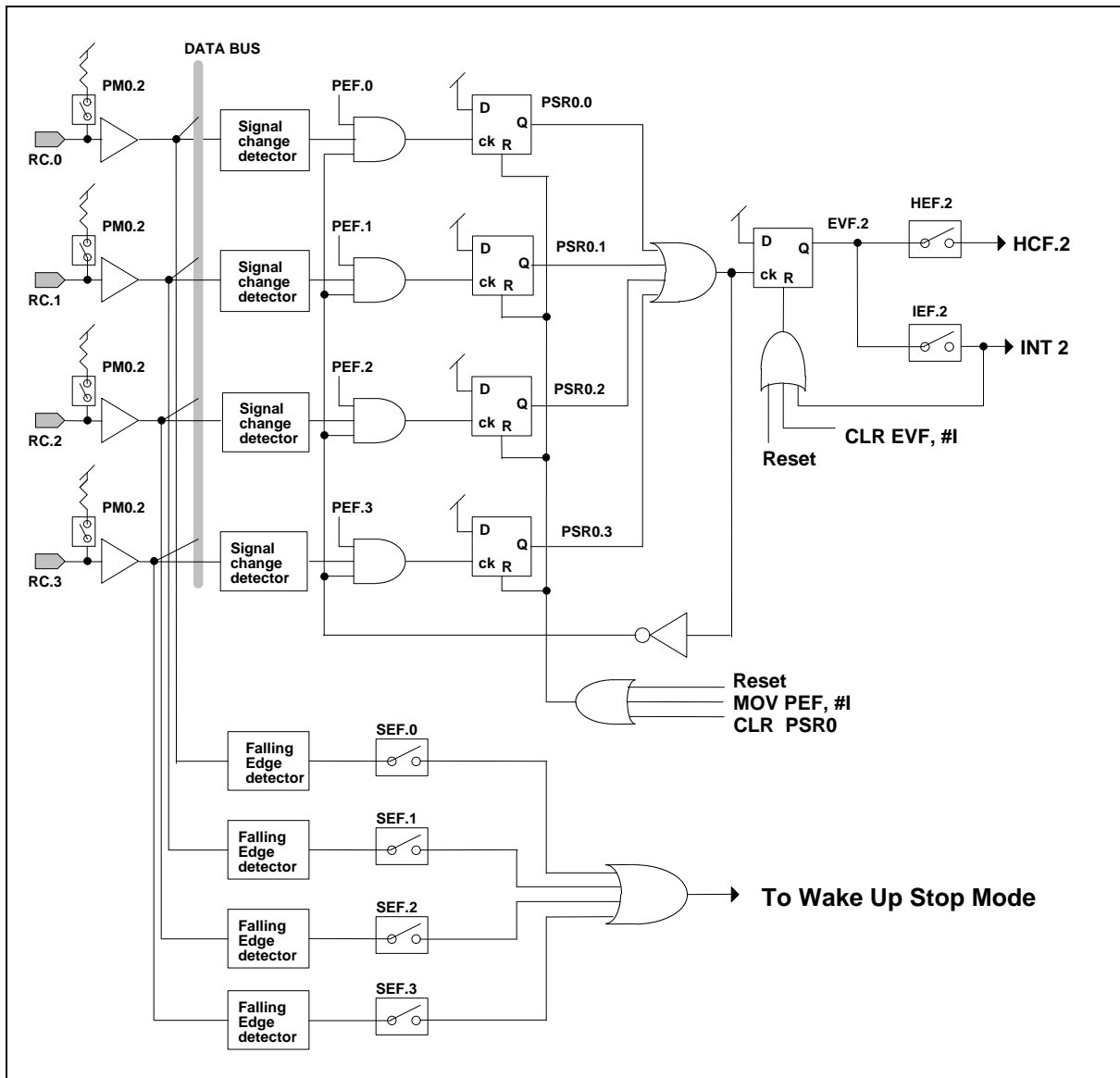
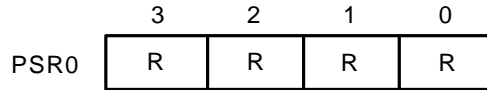

Figure 6-12 Architecture of Input Ports RC



## 6.18.1 Port Status Register 0 (PSR0)

Port status register 0 is organized as 4-bit binary register (PSR0.0 to PSR0.3). PSR0 can be read or cleared by the MOVA R, PSR0, and CLR PSR0 instructions. The bit descriptions are as follows:



Note: R means read only.

- Bit 0 = 1      Signal change at RC.0
- Bit 1 = 1      Signal change at RC.1
- Bit 2 = 1      Signal change at RC.2
- Bit 3 = 1      Signal change at RC.3

## 6.19 Output Port RE

Output port RE is used as an output of the internal RT port. When the MOV RE, R instruction is executed, the data in the RAM will be output to port RT through port RE. It provides a high sink current to drive an LED.

## 6.20 DTMF Output Pin (DTMF)

This pin should output the dual tone multi-frequency signal from the DTMF generator. There is the DTMF register that can specify the wanted low/high frequency. And control whether the dual tone will be output or not. The tones are divided into two groups (Row group and Col group) and one tone from each group is selected to represent a digit. The relation between the DTMF signal and the corresponding touch tone keypad is shown in Figure 6-13.

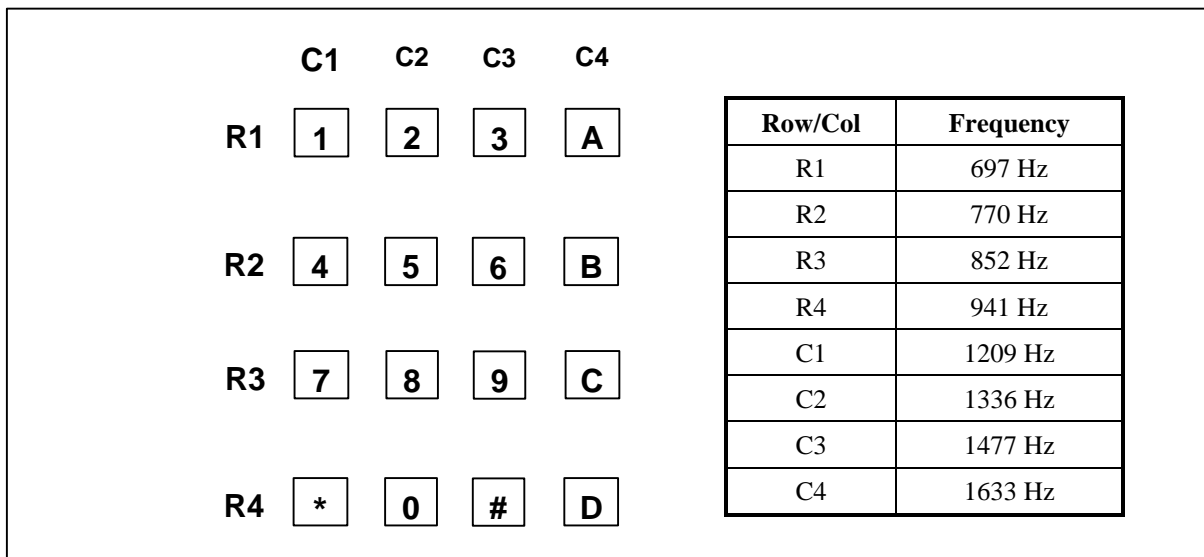
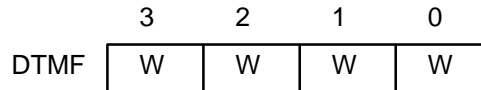

Figure 6-13 The relation between the touch tone keypad and the frequency



## 6.20.1 DTMF register

DTMF register is organized as 4-bit binary register. By controlling the DTMF register, one tone of the low/high group can be selected. The MOV DTMF,R instruction can specify the wanted tones. The bit descriptions are as follows:



Note: W means write only.

	B3	B2	B1	B0	SELECTED TONE
<b>High Group</b>	X	X	0	0	1209 Hz
	X	X	0	1	1336 Hz
	X	X	1	0	1477 Hz
	X	X	1	1	1633 Hz
<b>Low Group</b>	0	0	X	X	697 Hz
	0	1	X	X	770 Hz
	1	0	X	X	852 Hz
	1	1	X	X	941 Hz

Note: X means this bit do not care.

## 6.20.2 Dual Tone Control Register (DTCR)

Dual tone control register is organized as 4-bit binary register. The output of the dual or single tone will be controlled by this register. The MOV DTCR,#I instruction can specify the wanted status. The bit descriptions are as follows:

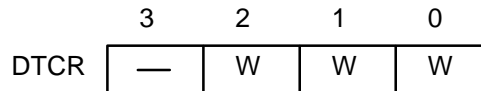

Note: W means write only.

Bit 0 = 1      Low group tone output is enabled.

Bit 1 = 1      High group tone output is enabled.

Bit 2 = 1      DTMF output is enabled. When Bit 2 is reset to 0, the DTMF output pin will be Hi-Z state.

Bit 3 is reserved.

## 6.21 MFP Output Pin (MFP)

The MFP output pin can output the Timer 1 clock or the modulation frequency; the output of the pin is determined by bit 0 of BUZCR (BUZCR.0). The organization of MR1 is shown in Figure 6-7. When bit 0 of BUZCR is reset to "0," the MFP output can deliver a modulation output in any combination of one signal from among DC, 4096 Hz, 2048 Hz, and one or more signals from among 128 Hz, 64 Hz, 8 Hz, 4 Hz, 2 Hz, or 1 Hz (when using a 32.768 KHz crystal). The MOV MFP, #I instruction is used to specify the modulation output combination. The data specified by the 8-bit operand and the MFP output pin are shown in next page.

# Preliminary W742C814



**Table 5** The relation between the MFP output frequency and the data specified by 8-bit operand

(Fosc = 32.768 KHz)

R7	R6	R5	R4	R3	R2	R1	R0	FUNCTION
0	0	0	0	0	0	0	0	Low level
		0	0	0	0	0	1	128 Hz
		0	0	0	0	1	0	64 Hz
		0	0	0	1	0	0	8 Hz
		0	0	1	0	0	0	4 Hz
		0	1	0	0	0	0	2 Hz
		1	0	0	0	0	0	1 Hz
0	1	0	0	0	0	0	0	High level
		0	0	0	0	0	1	128 Hz
		0	0	0	0	1	0	64 Hz
		0	0	0	1	0	0	8 Hz
		0	0	1	0	0	0	4 Hz
		0	1	0	0	0	0	2 Hz
		1	0	0	0	0	0	1 Hz
1	0	0	0	0	0	0	0	2048 Hz
		0	0	0	0	0	1	2048 Hz * 128 Hz
		0	0	0	0	1	0	2048 Hz * 64 Hz
		0	0	0	1	0	0	2048 Hz * 8 Hz
		0	0	1	0	0	0	2048 Hz * 4 Hz
		0	1	0	0	0	0	2048 Hz * 2 Hz
		1	0	0	0	0	0	2048 Hz * 1 Hz
1	1	0	0	0	0	0	0	4096 Hz
		0	0	0	0	0	1	4096 Hz * 128 Hz
		0	0	0	0	1	0	4096 Hz * 64 Hz
		0	0	0	1	0	0	4096 Hz * 8 Hz
		0	0	1	0	0	0	4096 Hz * 4 Hz
		0	1	0	0	0	0	4096 Hz * 2 Hz
		1	0	0	0	0	0	4096 Hz * 1 Hz





## 6.22 LCD Controller/Driver

The W742C814 can directly drive an LCD with 32 segment output pins and 4 common output pins for a total of  $32 \times 4$  dots. The LCD driving mode is 1/3 bias 1/4 duty. The alternating frequency of the LCD can be set as  $F_w/64$ ,  $F_w/128$ ,  $F_w/256$ , or  $F_w/512$ . The structure of the LCD alternating frequency ( $F_{LCD}$ ) is shown in the Figure 6-14.

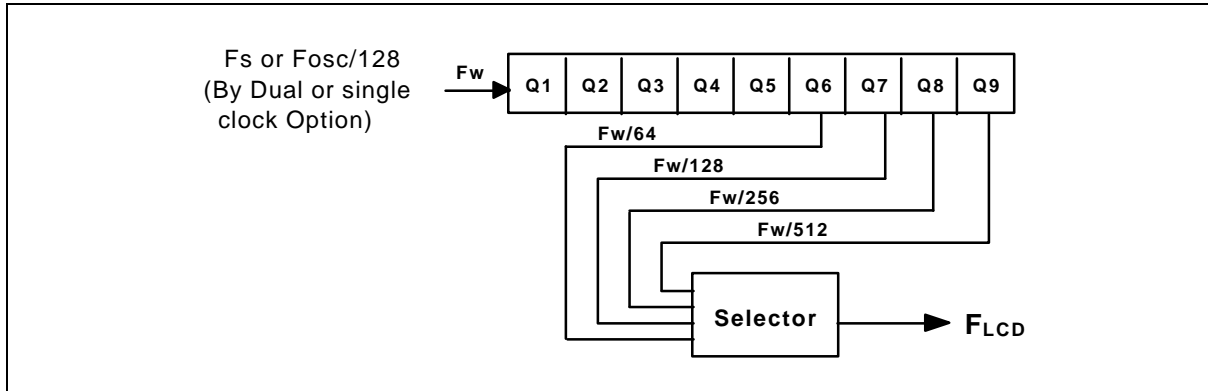

Figure 6-14 LCD alternating frequency ( $F_{LCD}$ ) circuit diagram

$F_w = 32.768$  KHz, the LCD frequency is as shown in the table below.

**Table 6 The relationship between the  $F_{LCD}$  and the duty cycle**

LCD Frequency	$F_w/64$ (512Hz)	$F_w/128$ (256 Hz)	$F_w/256$ (128 Hz)	$F_w/512$ (64 Hz)
<b>1/4 Duty</b>	128 Hz	64 Hz	32 Hz	16 Hz

Corresponding to the 32 LCD drive output pins, there are 32 LCD data RAM segments. Instructions such as MOV LPL,R, MOV LPH,R, MOV @LP,R, and MOV R,@LP are used to control the LCD data RAM. The data in the LCD data RAM are transferred to the segment output pins automatically without program control. When the bit value of the LCD data RAM is "1," the LCD is turned on. When the bit value of the LCD data RAM is "0," LCD is turned off. The contents of the LCD data RAM (LCDR) are sent out through the segment0 to segment32 pins by a direct memory access. The relation between the LCD data RAM and segment/common pins is shown below.

**Table 7 The reation between the LCDR and segment/common pins used as LCD drive output pins**

		COM3	COM2	COM1	COM0
LCD DATA RAM	OUTPUT PIN	BIT 3	BIT 2	BIT 1	BIT 0
LCDR00	SEG0	0/1	0/1	0/1	0/1
LCDR01	SEG1	0/1	0/1	0/1	0/1
⋮	⋮	⋮	⋮	⋮	⋮
⋮	⋮	⋮	⋮	⋮	⋮
LCDR1E	SEG30	0/1	0/1	0/1	0/1
LCDR1F	SEG31	0/1	0/1	0/1	0/1



The LCDON instruction turns the LCD display on (even in HOLD mode), and the LCDOFF instruction turns the LCD display off. At initial reset, all the LCD segments are unlit. When the initial reset state ends, the LCD display is turned off automatically. To turn on the LCD display, the instruction LCDON must be executed.

## 6.22.1 LCD RAM addressing method

There are 32 LCD RAMs (LCDR00 – Lcdr1F) that should be indirectly addressed. The LCD RAM pointer (LP) is used to point to the address of the wanted LCD RAM. The LP is organized as 6-bit binary register. The MOV LPL,R and MOV LPH,R instructions can load the LCD RAM address to the LP from R. The MOV @LP,R and MOV R,@LP instructions can access the pointed LCD RAM content.

## 6.22.2 The output waveforms for the LCD driving mode

1/3 bias 1/4 duty Lighting System (Example)

Normal Operating Mode

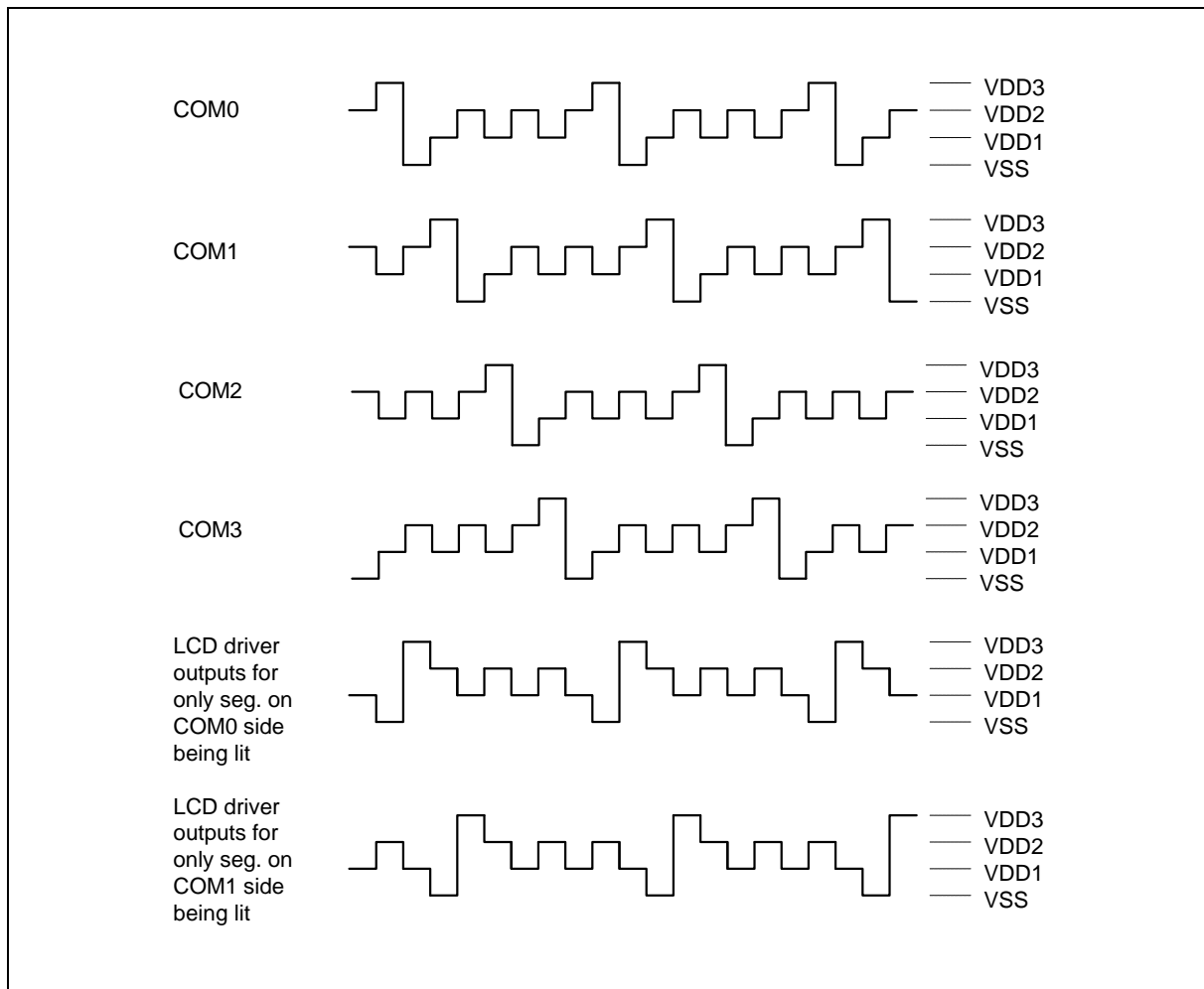

# Preliminary W742C814



Continued

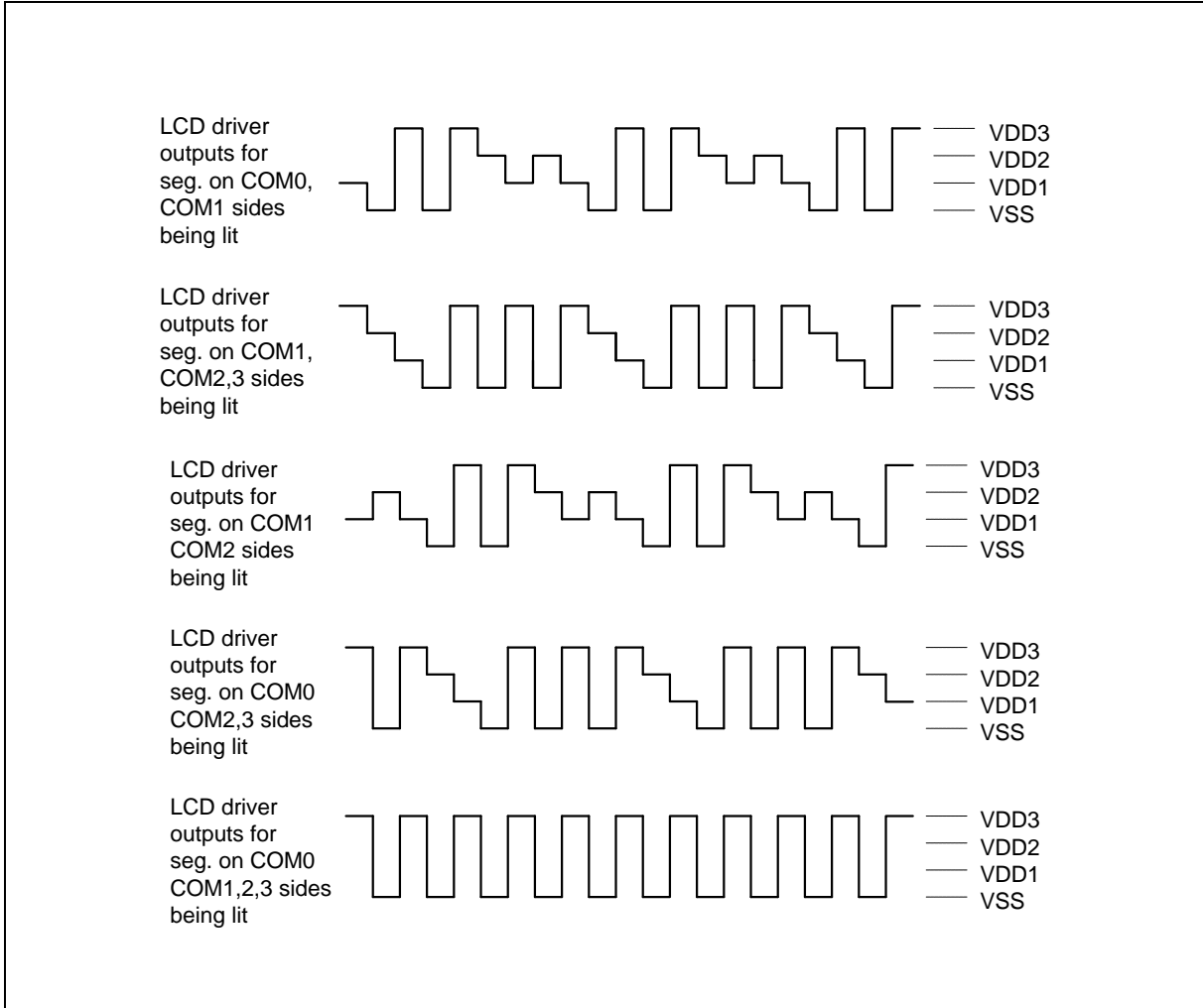

The power connections for the 1/3 bias 1/4 duty LCD driving mode are shown below.

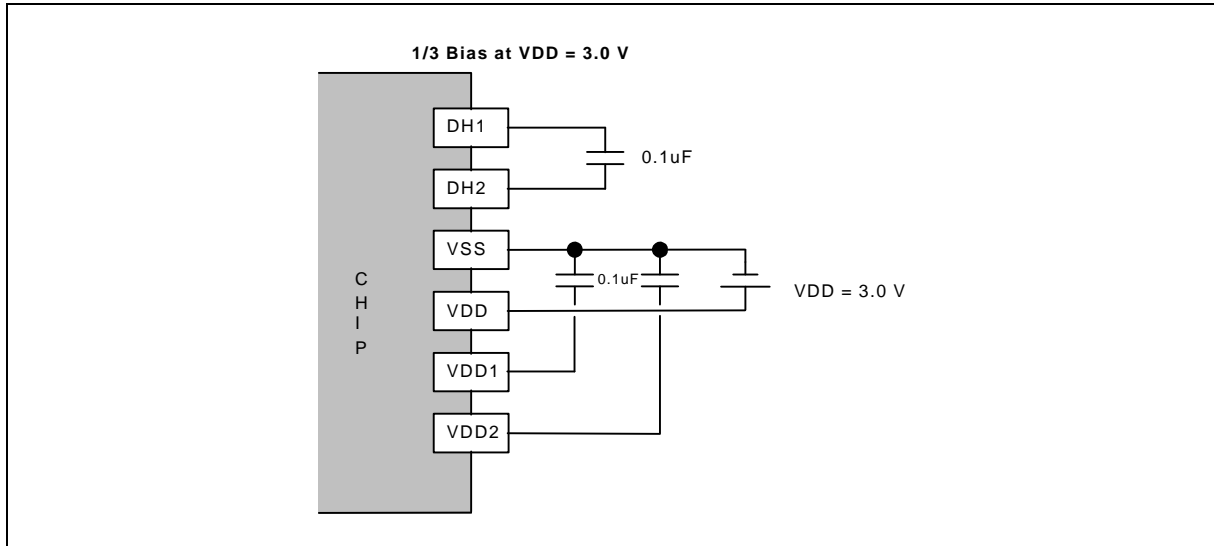

## 7. ABSOLUTE MAXIMUM RATINGS

PARAMETER	RATING	UNIT
Supply Voltage to Ground Potential	-0.3 to +7.0	V
Applied Input/Output Voltage	-0.3 to +7.0	V
Power Dissipation	120	mW
Ambient Operating Temperature	0 to +70	°C
Storage Temperature	-55 to +150	°C

Note: Exposure to conditions beyond those listed under Absolute Maximum Ratings may adversely affect the life and reliability of the device.

## 8. DC CHARACTERISTICS

(V<sub>DD</sub>-V<sub>SS</sub> = 3.0 V, F<sub>m</sub> = 3.58 MHz, F<sub>s</sub> = 32.768 KHz, T<sub>a</sub> = 25° C, LCD on; unless otherwise specified)

PARAMETER	SYM.	CONDITIONS	MIN.	TYP.	MAX.	UNIT
Op. Voltage	V <sub>DD</sub>	-	2.4	-	5.5	V
Op. Current (Crystal type)	I <sub>OP1</sub>	No load (Ext-V) In dual-clock normal operation	-	0.7	1.0	mA
Op. Current (Crystal type)	I <sub>OP3</sub>	No load (Ext-V) In dual-clock slow operation and F <sub>m</sub> is stopped	-	-	20	μA

# Preliminary W742C814



DC Characteristics, continued

PARAMETER	SYM.	CONDITIONS	MIN.	TYP.	MAX.	UNIT
Hold Current (Crystal type)	IHM1	Hold mode No load (Ext-V) In dual-clock normal operation	-	-	450	$\mu$ A
Hold Current (Crystal type)	IHM3	Hold mode No load (Ext-V) In dual-clock slow operation and Fm is stopped	-	6	15	$\mu$ A
Stop Current (Crystal type)	ISM1	Stop mode No load (Ext-V) LCD driver must be turned off	-	1	2	$\mu$ A
Input Low Voltage	VIL	-	VSS	-	0.3 VDD	V
Input High Voltage	VIH	-	0.7 VDD	-	VDD	V
MFP Output Low Voltage	VML	IOL = 3.5 mA	-	-	0.4	V
MFP Output High Voltage	VMH	IOH = 3.5 mA	2.4	-	-	V
Port RA, RB and RD Output Low Voltage	VABL	IOL = 2.0 mA	-	-	0.4	V
Port RA, RB and RD Output high Voltage	VABH	IOH = 2.0 mA	2.4	-	-	V
LCD Supply Current	ILCD	All Seg. ON	-	-	6	$\mu$ A
SEG0-SEG31 Sink Current (Used as LCD output)	IOL1	VOL = 0.4V VLCD = 0.0V	90	-	-	$\mu$ A
SEG0-SEG31 Drive Current (Used as LCD output)	IOH1	VOH = 2.4V VLCD = 3.0V	90	-	-	$\mu$ A
Port RE Sink Current	IEL	VOL = 0.9V	9	-	-	mA
Port RE Source Current	IEH	VOH = 2.4V	0.4	1.2	-	mA
DTMF Output DC level	VTDC	RL = 5 K $\Omega$ , VDD = 2.5 to 3.8V	1.1	-	2.8	V
DTMF Distortion	THD	RL = 5 K $\Omega$ , VDD = 2.5 to 3.8V	-	-30	-23	dB
DTMF Output Voltage	VTO	Low group, RL = 5K $\Omega$	130	150	170	mVrms
Pre-emphasis		Col/Row	1	2	3	dB
DTMF Output Sink Current	ITL	VTO = 0.5V	0.2	-	-	mA
Pull-up Resistor	RC	Port RC	100	350	1000	K $\Omega$
RES Pull-up Resistor	RRES	-	20	100	500	K $\Omega$

Publication Release Date: May 2001  
Revision A1



## 9. AC CHARACTERISTICS

PARAMETER	SYM.	CONDITIONS	MIN.	TYP.	MAX.	UNIT
Op. Frequency	FOSC	Crystal type	-	3.58	-	MHz
Instruction Cycle Time	T <sub>I</sub>	One machine cycle	-	4/FOSC	-	S
Reset Active Width	T <sub>RAW</sub>	FOSC = 32.768 KHz	1	-	-	μS
Interrupt Active Width	T <sub>IAW</sub>	FOSC = 32.768 KHz	1	-	-	μS

## 10. INSTRUCTION SET TABLE

### Symbol Description

ACC:	Accumulator
ACC.n:	Accumulator bit n
WR:	Working Register
WRP:	WR Page Register
PAGE:	Page Register
DBKR:	Data Bank Register
ROMPR:	ROM Page Register
MR0:	Mode Register 0
MR1:	Mode Register 1
PM0:	Port Mode 0
PM1:	Port Mode 1
PM2:	Port Mode 2
PM5:	Port Mode 5
PSR0:	Port Status Register 0
R:	Memory (RAM) of address R
WDTR:	WatchDog Timer Register
LPL:	LCD data RAM pointer
LPH:	LCD data RAM pointer
R.n:	Memory bit n of address R
SCR:	System Control Register
BUZCR:	Buzzer Control Register
RA:	I/O Port RA
RC:	I/O Port RC
DTMF:	DTMF Register
DTCR:	MTMF Control Pin
MFP:	MFP Output Pin



Continued

I:	Constant parameter
L:	Branch or Jump address
CF:	Carry Flag
ZF:	Zero Flag
PC:	Program Counter
TM0L:	Low nibble of the Timer 0 counter
TM0H:	High nibble of the Timer 0 counter
TM1L:	Low nibble of the Timer 1 counter
TM1H:	High nibble of the Timer 1 counter
TAB0:	Look-up table address buffer 0
TAB1:	Look-up table address buffer 1
TAB2:	Look-up table address buffer 2
TAB3:	Look-up table address buffer 3
IEF.n:	Interrupt Enable Flag n
HCF.n:	HOLD mode release Condition Flag n
HEF.n:	HOLD mode release Enable Flag n
SEF.n:	STOP mode wake-up Enable Flag n
PEF.n:	Port Enable Flag n
EVF.n:	Event Flag n
! =:	Not equal
&:	AND
^:	OR
EX:	Exclusive OR
←:	Transfer direction, result
[PAGE*10H+():]	Contents of address PAGE(bit2, bit1, bit0)*10H+()
[P():]	Contents of port P

# Preliminary W742C814



MACHINE CODE	MNEMONIC	FUNCTION	FLAG AFFECTED	W/C
<b>Arithmetic</b>				
0001 1000 0xxx xxxx	ADD R, ACC	ACC←(R) + (ACC)	ZF, CF	1/1
0001 1100 iiii nnnn	ADD WRn, #I	ACC←(WRn) + I	ZF, CF	1/1
0001 1001 0xxx xxxx	ADDR R, ACC	ACC, R←(R) + (ACC)	ZF, CF	1/1
0001 1101 iiii nnnn	ADDR WRn, #I	ACC, WRn←(WRn) + I	ZF, CF	1/1
0000 1000 0xxx xxxx	ADC R, ACC	ACC←(R) + (ACC) + (CF)	ZF, CF	1/1
0000 1100 iiii nnnn	ADC WRn, #I	ACC←(WRn) + I + (CF)	ZF, CF	1/1
0000 1001 0xxx xxxx	ADCR R, ACC	ACC, R←(R) + (ACC) + (CF)	ZF, CF	1/1
0000 1101 iiii nnnn	ADCR WRn, #I	ACC, WRn←(WRn) + I + (CF)	ZF, CF	1/1
0010 1000 0xxx xxxx	ADU R, ACC	ACC←(R) + (ACC)	ZF	1/1
0010 1100 iiii nnnn	ADU WRn, #I	ACC←(WRn) + I	ZF	1/1
0010 1001 0xxx xxxx	ADUR R, ACC	ACC, R←(R) + (ACC)	ZF	1/1
0010 1101 iiii nnnn	ADUR WRn, #I	ACC, WRn←(WRn) + I	ZF	1/1
0001 1010 0xxx xxxx	SUB R, ACC	ACC←(R) - (ACC)	ZF, CF	1/1
0001 1110 iiii nnnn	SUB WRn, #I	ACC←(WRn) - I	ZF, CF	1/1
0001 1011 0xxx xxxx	SUBR R, ACC	ACC, R←(R) - (ACC)	ZF, CF	1/1
0001 1111 iiii nnnn	SUBR WRn, #I	ACC, WRn←(WRn) - I	ZF, CF	1/1
0000 1010 0xxx xxxx	SBC R, ACC	ACC←(R) - (ACC) - (CF)	ZF, CF	1/1
0000 1110 iiii nnnn	SBC WRn, #I	ACC←(WRn) - I - (CF)	ZF, CF	1/1
0000 1011 0xxxxxxx	SBCR R, ACC	ACC, R←(R) - (ACC) - (CF)	ZF, CF	1/1
0000 1111 iiii nnnn	SBCR WRn, #I	ACC, WRn←(WRn) - I - (CF)	ZF, CF	1/1
0100 1010 0xxx xxxx	INC R	ACC, R←(R) + 1	ZF, CF	1/1
0100 1010 1xxx xxxx	DEC R	ACC, R←(R) - 1	ZF, CF	1/1



# Preliminary W742C814



Instruction set, continued

MACHINE CODE	MNEMONIC	FUNCTION	FLAG AFFECTED	W/C
<b>Logic</b>				
0010 1010 0xxx xxxx	ANL R, ACC	ACC←(R) & (ACC)	ZF	1/1
0010 1110 iiii nnnn	ANL WRn, #I	ACC←(WRn) & I	ZF	1/1
0010 1011 0xxx xxxx	ANLR R, ACC	ACC, R←(R) & (ACC)	ZF	1/1
0010 1111 iiii nnnn	ANLR WRn, #I	ACC, WRn←(WRn) & I	ZF	1/1
0011 1010 0xxx xxxx	ORL R, ACC	ACC←(R) ^ (ACC)	ZF	1/1
0011 1110 iiii nnnn	ORL WRn, #I	ACC←(WRn) ^ I	ZF	1/1
0011 1011 0xxx xxxx	ORLR R, ACC	ACC, R←(R) ^ (ACC)	ZF	1/1
0011 1111 iiii nnnn	ORLR WRn, #I	ACC, WRn←(WRn) ^ I	ZF	1/1
0011 1000 0xxx xxxx	XRL R, ACC	ACC←(R) EX (ACC)	ZF	1/1
0011 1100 iiii nnnn	XRL WRn, #I	ACC←(WRn) EX I	ZF	1/1
0011 1001 0xxx xxxx	XRLR R, ACC	ACC, R←(R) EX (ACC)	ZF	1/1
0011 1101 iiii nnnn	XRLR WRn, #I	ACC, WRn←(WRn) EX I	ZF	1/1
<b>Branch</b>				
0111 0aaa aaaa aaaa	JMP L	PC12-PC0←(ROMPR)×800H+L10-L0		1/1
1000 0aaa aaaa aaaa	JB0 L	PC10-PC0←L10-L0; if ACC.0 = "1"		1/1
1001 0aaa aaaa aaaa	JB1 L	PC10-PC0←L10-L0; if ACC.1 = "1"		1/1
1010 0aaa aaaa aaaa	JB2 L	PC10-PC0←L10-L0; if ACC.2 = "1"		1/1
1011 0aaa aaaa aaaa	JB3 L	PC10-PC0←L10-L0; if ACC.3 = "1"		1/1
1110 0aaa aaaa aaaa	JZ L	PC10-PC0←L10-L0; if ACC = 0		1/1
1100 0aaa aaaa aaaa	JNZ L	PC10-PC0←L10-L0; if ACC ≠ 0		1/1
1111 0aaa aaaa aaaa	JC L	PC10-PC0←L10-L0; if CF = "1"		1/1
1101 0aaa aaaa aaaa	JNC L	PC10-PC0←L10-L0; if CF ≠ "1"		1/1
0100 1000 0xxx xxxx	DSKZ R	ACC, R←(R) - 1; PC ← (PC) + 2 if ACC = 0	ZF, CF	1/1
0100 1000 1xxx xxxx	DSKN R Z	ACC, R←(R) - 1; PC ← (PC) + 2 if ACC ≠ 0	ZF, CF	1/1
1010 1000 0xxx xxxx	SKB0 R	PC ← (PC) + 2 if R.0 = "1"		1/1
1010 1000 1xxx xxxx	SKB1 R	PC ← (PC) + 2 if R.1 = "1"		1/1
1010 1001 0xxx xxxx	SKB2 R	PC ← (PC) + 2 if R.2 = "1"		1/1
1010 1001 1xxx xxxx	SKB3 R	PC ← (PC) + 2 if R.3 = "1"		1/1

# Preliminary W742C814



Instruction set, continued

MACHINE CODE	MNEMONIC	FUNCTION	FLAG AFFECTED	W/C
<b>Data move</b>				
0001 0000 0000 iiiii	MOV ACC, #I	ACC←I	ZF	1/1
1110 1nnn nxxx xxxxx	MOV WRn, R	WRn←(R)		1/1
1001 1001 iiiii nnnn	MOV WRn, #I	WRn←I		1/1
1111 1nnn nxxx xxxxx	MOV R, WRn	R←(WRn)		1/1
0110 1nnn nxxx xxxxx	MOVA WRn, R	ACC, WRn←(R)	ZF	1/1
0111 1nnn nxxx xxxxx	MOVA R, WRn	ACC, R←(WRn)	ZF	1/1
0101 1001 1xxx xxxxx	MOV R, ACC	R←(ACC)		1/1
0100 1110 1xxx xxxxx	MOV ACC, R	ACC←(R)	ZF	1/1
1011 1iii ixxx xxxxx	MOV R, #I	R←I		1/1
1100 1nnn n000 qqqq	MOV WRn, @WRq	WRn←[(DBKR)×80H+(PAGE)×10H+(WRq)]		1/2
1101 1nnn n000 qqqq	MOV @WRq, WRn	[(DBKR)×80H+(PAGE)×10H+(WRq)]←WRn		1/2
1000 1100 0xxx xxxxx	MOV TAB0, R	TAB0←(R)		1/1
1000 1100 1xxx xxxxx	MOV TAB1, R	TAB1←(R)		1/1
1000 1110 0xxx xxxxx	MOV TAB2, R	TAB2←(R)		1/1
1000 1110 1xxx xxxxx	MOV TAB3, R	TAB3←(R)		1/1
1000 1101 0xxx xxxxx	MOVC R	R←[(TAB3)×1000H+(TAB2)×100H+(TAB1)×10H +		1/2
<b>Input &amp; Output</b>				
0101 1011 0xxx xxxxx	MOVA R, RA	ACC, R←[RA]	ZF	1/1
0101 1011 1xxx xxxxx	MOVA R, RB	ACC, R←[RB]	ZF	1/1
0100 1011 0xxx xxxxx	MOVA R, RC	ACC, R←[RC]	ZF	1/1
0100 1011 1xxx xxxxx	MOVA R, RD	ACC, R←[RD]	ZF	1/1
0101 1010 0xxx xxxxx	MOV RA, R	[RA]←(R)		1/1
0101 1010 1xxx xxxxx	MOV RB, R	[RB]←(R)		1/1
0100 1010 0xxx xxxxx	MOV RC, R	[RC]←(R)		1/1
1010 1100 1xxx xxxxx	MOV RD, R	[RD]←(R)		1/1
0101 1110 0xxx xxxxx	MOV RE, R	[RE]←(R)		1/1

# Preliminary W742C814



Instruction set, continued

MACHINE CODE	MNEMONIC	FUNCTION	FLAG AFFECTED	W/C
<b>Flag &amp; Register</b>				
0101 1111 1xxx xxxx	MOVA R, PAGE	ACC, R←PAGE (Page Register)	ZF	1/1
0101 1110 1xxx xxxx	MOV PAGE, R	PAGE←(R)		1/1
0101 0110 1000 0iii	MOV PAGE, #I	PAGE←I		1/1
1001 1101 1xxx xxxx	MOV R, WRP	R←WRP		1/1
1001 1100 1xxx xxxx	MOV WRP, R	WRP←(R)		1/1
0011 0101 1000 iiiii	MOV WRP, #I	WRP←I		1/1
10011101 0000 nnnn	MOV WRn,DBKR	WRn←DBKR		1/1
10011111 0000 nnnn	MOV WRn,TM1	WRn←TM1.4 - TM1.7, ACC←TM1.0 - TM1.3		1/1
10011100 0000 nnnn	MOV DBKR, WRn	DBKR←WRn		1/1
0011 0101 0000 iiiii	MOV DBKR, #I	DBKR←I		1/1
0011 0100 0000 0iii	MOV ROMPR, #I	ROMPR←I		1/1
1000 1000 0xxx xxxx	MOV ROMPR, R	ROMPR←(R)		1/1
1000 1001 0xxx xxxx	MOV R, ROMPR	R←(ROMPR)		1/1
0101 1001 0xxx xxxx	MOVA R, CF	ACC.0, R.0←CF	ZF	1/1
0101 1000 0xxx xxxx	MOV CF, R	CF←(R.0)	CF	1/1
0100 1001 0xxx xxxx	MOVA R, HCF.L	ACC, R←HCF.0~HCF.3	ZF	1/1
0100 1001 1xxx xxxx	MOVA R, HCF.H	ACC, R←HCF.4~HCF.7	ZF	1/1
0101 0011 0000 iiiii	MOV PM0, #I	Port Mode 0← I		1/1
0101 0111 0000 iiiii	MOV PM1, #I	Port Mode 1← I		1/1
0101 0111 1000 iiiii	MOV PM2, #I	Port Mode 2← I		1/1
0011 0111 1000 iiiii	MOV PM5, #I	Port Mode 5← I		1/1
0100 0000 i00i 0iii	CLR EVF, #I	Clear Event Flag if In = 1		1/1
0101 1101 0xxx xxxx	MOVA R, EVFL	R← EVF.0 - EVF.3		1/1
0101 1101 1xxx xxxx	MOVA R, EVFH	R← EVF.4 - EVF.7		1/1
0100 0001 i00i 0iii	MOV HEF, #I	Set/Reset HOLD mode release Enable Flag		1/1
0101 0001 i00i 0iii	MOV IEF, #I	Set/Reset Interrupt Enable Flag		1/1
0100 0011 0000 iiiii	MOV PEF, #I	Set/Reset Port Enable Flag		1/1
0101 0010 0000 iiiii	MOV SEF, #I	Set/Reset STOP mode wake-up Enable Flag for RC port		1/1

Publication Release Date: May 2001  
Revision A1

# Preliminary W742C814



Instruction set, continued

MACHINE CODE	MNEMONIC	FUNCTION	FLAG AFFECTED	W/C
<b>Flag &amp; Register</b>				
0101 0100 0000 i 0 ii	MOV SCR, #I	SCR←I		1/1
0100 1111 0xxx xxxx	MOVA R, PSR0	ACC, R←Port Status Register 0	ZF	1/1
0100 0010 0000 0000	CLR PSR0	Clear Port Status Register 0		1/1
0101 0000 0100 0000	SET CF	Set Carry Flag	CF	1/1
0101 0000 0000 0000	CLR CF	Clear Carry Flag	CF	1/1
0001 0111 0000 0000	CLR DIVR0	Clear the last 4-bit of the Divider 0		1/1
0101 0101 1000 0000	CLR DIVR1	Clear the last 4-bit of the Divider 1		1/1
0101 0110 0000 i iii	MOV WDTR, #I	WDTR←I		1/1
0101 1111 0xxx xxxx	MOVA R, WDTR	ACC, R←Watchdog Timer Register		1/1
0001 0111 1000 0000	CLR WDT	Clear Watchdog Timer		1/1
<b>DTMF</b>				
1001 1110 1xxx xxxx	MOV DTMF, R	DTMF←(R)		1/1
0011 0100 1000 0iii	MOV DTCR, I	DTCR←I		1/1
<b>Shift &amp; Rotate</b>				
0100 1101 0xxx xxxx	SHRC R	ACC.n, R.n←(R.n+1); ACC.3, R.3←0; CF←R.0	ZF, CF	1/1
0100 1101 1xxx xxxx	RRC R	ACC.n, R.n←(R.n+1); ACC.3, R.3←CF; CF←R.0	ZF, CF	1/1
0100 1100 0xxx xxxx	SHLC R	ACC.n, R.n←(R.n-1); ACC.0, R.0←0; CF←R.3	ZF, CF	1/1
0100 1100 1xxx xxxx	RLC R	ACC.n, R.n←(R.n-1); ACC.0, R.0←CF; CF←R.3	ZF, CF	1/1
<b>LCD</b>				
1001 1000 0xxx xxxx	MOV LPL, R	LPL←(R)		1/1
1001 1000 1xxx xxxx	MOV LPH, R	LPH←(R)		1/1
1001 1010 0xxx xxxx	MOV @LP, R	[(LPH)×10H+(LPL)]←(R)		1/1
1001 1011 0xxx xxxx	MOV R, @LP	R←[(LPH)×10H+(LPL)]		1/1
0000 0010 0000 0000	LCDON	LCD ON		1/1
0000 0010 1000 0000	LCDOFF	LCD OFF		1/1

# Preliminary W742C814



Instruction set, continued

MACHINE CODE	MNEMONIC	FUNCTION	FLAG AFFECTED	W/C
<b>MFP</b>				
0011 0110 0000 000i	MOV BUZCR, #I	BUZCR ← I		1/1
1000 1010 0xxx xxxx	MOV BUZCR, R	BUZCR ← (R)		1/1
1000 1011 0xxx xxxx	MOV R, BUZCR	R ← (BUZCR)		1/1
0001 0010 iiiiii	MOV MFP, #I	[MFP] ← I		1/1
<b>Timer</b>				
1010 1010 0xxx xxxx	MOV TM0L, R	TM0L ← (R)		1/1
1010 1010 1xxx xxxx	MOV TM0H, R	TM0H ← (R)		1/1
1010 1011 0xxx xxxx	MOV TM1L, R	TM1L ← (R)		1/1
1010 1011 1xxx xxxx	MOV TM1H, R	TM1H ← (R)		1/1
0001 0011 1000 i00i	MOV MR0, #I	MR0 ← (R)		1/1
0001 0011 0000 iiiiii	MOV MR1, #I	MR1 ← (R)		1/1
<b>Other</b>				
0000 0000 1000 0000	HOLD	Enter Hold mode		1/1
0000 0000 1100 0000	STOP	Enter Stop mode		1/1
0000 0000 0000 0000	NOP	No operation		1/1
0101 0000 1100 0000	EN INT	Enable interrupt function		1/1
0101 0000 1000 0000	DIS INT	Disable interrupt function		1/1
<b>Subroutine</b>				
0110 0aaa aaaa aaaa	CALL L	Push Stack: STACK ← PC+1, TAB0, TAB1, TAB2, TAB3, DBKR, WRP, ROMPR, PAGE, ACC, CF; PC12~PC0 ← (ROMPR)x800H+L10~L0		1/1
0000 0001 iiiiii	RTN #I	(PC) ← STACK; Pop other register by I Table setting (Refer to Table 8)		1/1



**Table 8 The bit definition of RTN**

Bit definition of I	
I = 0000 0000	Pop <b>PC</b> from stack only
bit0 = 1	Pop <b>PC</b> and <b>TAB0, TAB1, TAB2, TAB3</b> from stack
bit1 = 1	Pop <b>PC</b> and <b>DBKR</b> from stack
bit2 = 1	Pop <b>PC</b> and <b>WRP</b> from stack
bit3 = 1	Pop <b>PC</b> and <b>ROMPR</b> from stack
bit4 = 1	Pop <b>PC</b> and <b>PAGE</b> from stack
bit5 = 1	Pop <b>PC</b> and <b>ACC</b> from stack
bit6 = 1	Pop <b>PC</b> and <b>CF</b> from stack



**Headquarters**

No. 4, Creation Rd. III,  
Science-Based Industrial Park,  
Hsinchu, Taiwan  
TEL: 886-3-5770066  
FAX: 886-3-5792766  
<http://www.winbond.com.tw/>  
Voice & Fax-on-demand: 886-2-27197006

**Taipei Office**

11F, No. 115, Sec. 3, Min-Sheng East Rd.,  
Taipei, Taiwan  
TEL: 886-2-27190505  
FAX: 886-2-27197502

**Winbond Electronics (H.K.) Ltd.**

Unit 9-15, 22F, Millennium City,  
No. 378 Kwun Tong Rd;  
Kowloon, Hong Kong  
TEL: 852-27513100  
FAX: 852-27552064

**Winbond Electronics North America Corp.**

**Winbond Memory Lab.**  
**Winbond Microelectronics Corp.**  
**Winbond Systems Lab.**  
2727 N. First Street, San Jose,  
CA 95134, U.S.A.  
TEL: 408-9436666  
FAX: 408-5441798

Note: All data and specifications are subject to change without notice.