

To all our customers

Regarding the change of names mentioned in the document, such as Hitachi Electric and Hitachi XX, to Renesas Technology Corp.

The semiconductor operations of Mitsubishi Electric and Hitachi were transferred to Renesas Technology Corporation on April 1st 2003. These operations include microcomputer, logic, analog and discrete devices, and memory chips other than DRAMs (flash memory, SRAMs etc.) Accordingly, although Hitachi, Hitachi, Ltd., Hitachi Semiconductors, and other Hitachi brand names are mentioned in the document, these names have in fact all been changed to Renesas Technology Corp. Thank you for your understanding. Except for our corporate trademark, logo and corporate statement, no changes whatsoever have been made to the contents of the document, and these changes do not constitute any alteration to the contents of the document itself.

Renesas Technology Home Page: <http://www.renesas.com>

Renesas Technology Corp.
Customer Support Dept.
April 1, 2003

Cautions

Keep safety first in your circuit designs!

1. Renesas Technology Corporation puts the maximum effort into making semiconductor products better and more reliable, but there is always the possibility that trouble may occur with them. Trouble with semiconductors may lead to personal injury, fire or property damage.

Remember to give due consideration to safety when making your circuit designs, with appropriate measures such as (i) placement of substitutive, auxiliary circuits, (ii) use of nonflammable material or (iii) prevention against any malfunction or mishap.

Notes regarding these materials

1. These materials are intended as a reference to assist our customers in the selection of the Renesas Technology Corporation product best suited to the customer's application; they do not convey any license under any intellectual property rights, or any other rights, belonging to Renesas Technology Corporation or a third party.
2. Renesas Technology Corporation assumes no responsibility for any damage, or infringement of any third-party's rights, originating in the use of any product data, diagrams, charts, programs, algorithms, or circuit application examples contained in these materials.
3. All information contained in these materials, including product data, diagrams, charts, programs and algorithms represents information on products at the time of publication of these materials, and are subject to change by Renesas Technology Corporation without notice due to product improvements or other reasons. It is therefore recommended that customers contact Renesas Technology Corporation or an authorized Renesas Technology Corporation product distributor for the latest product information before purchasing a product listed herein.
The information described here may contain technical inaccuracies or typographical errors. Renesas Technology Corporation assumes no responsibility for any damage, liability, or other loss rising from these inaccuracies or errors.
Please also pay attention to information published by Renesas Technology Corporation by various means, including the Renesas Technology Corporation Semiconductor home page (<http://www.renesas.com>).
4. When using any or all of the information contained in these materials, including product data, diagrams, charts, programs, and algorithms, please be sure to evaluate all information as a total system before making a final decision on the applicability of the information and products. Renesas Technology Corporation assumes no responsibility for any damage, liability or other loss resulting from the information contained herein.
5. Renesas Technology Corporation semiconductors are not designed or manufactured for use in a device or system that is used under circumstances in which human life is potentially at stake. Please contact Renesas Technology Corporation or an authorized Renesas Technology Corporation product distributor when considering the use of a product contained herein for any specific purposes, such as apparatus or systems for transportation, vehicular, medical, aerospace, nuclear, or undersea repeater use.
6. The prior written approval of Renesas Technology Corporation is necessary to reprint or reproduce in whole or in part these materials.
7. If these products or technologies are subject to the Japanese export control restrictions, they must be exported under a license from the Japanese government and cannot be imported into a country other than the approved destination.
Any diversion or reexport contrary to the export control laws and regulations of Japan and/or the country of destination is prohibited.
8. Please contact Renesas Technology Corporation for further details on these materials or the products contained therein.

Hitachi Microcomputer

H8/3004, H8/3005

Hardware Manual

Preface

The H8/3004 and H8/3005 are high-performance single-chip microcontrollers that integrate system supporting functions together with an H8/300H CPU core.

The H8/300H CPU has a 32-bit internal architecture with sixteen 16-bit general registers, and a concise, optimized instruction set designed for speed. It can address a 16-Mbyte linear address space.

The on-chip system supporting functions include RAM, a 16-bit integrated timer unit (ITU), a watchdog timer (WDT), a serial communication interface (SCI), an A/D converter, I/O ports, and other facilities.

Two operating modes offer a choice of address space size.

This manual describes the H8/3004 and H8/3005 hardware. For details of the instruction set, refer to the H8/300H Programming Manual.

Contents

Section 1	Overview.....	1
1.1	Overview	1
1.2	Block Diagram.....	4
1.3	Pin Description	5
1.3.1	Pin Arrangement.....	5
1.3.2	Pin Functions	6
1.4	Pin Functions	9
Section 2	CPU	13
2.1	Overview	13
2.1.1	Features.....	13
2.1.2	Differences from H8/300 CPU	14
2.2	CPU Operating Modes.....	15
2.3	Address Space.....	16
2.4	Register Configuration.....	17
2.4.1	Overview.....	17
2.4.2	General Registers.....	18
2.4.3	Control Registers	19
2.4.4	Initial CPU Register Values	20
2.5	Data Formats.....	21
2.5.1	General Register Data Formats.....	21
2.5.2	Memory Data Formats	22
2.6	Instruction Set.....	24
2.6.1	Instruction Set Overview	24
2.6.2	Instructions and Addressing Modes.....	25
2.6.3	Tables of Instructions Classified by Function.....	26
2.6.4	Basic Instruction Formats	36
2.6.5	Notes on Use of Bit Manipulation Instructions	37
2.7	Addressing Modes and Effective Address Calculation	37
2.7.1	Addressing Modes	37
2.7.2	Effective Address Calculation	40
2.8	Processing States	44
2.8.1	Overview.....	44
2.8.2	Program Execution State	45
2.8.3	Exception-Handling State.....	45
2.8.4	Exception-Handling Sequences	47
2.8.5	Reset State	48
2.8.6	Power-Down State	48

2.9	Basic Operational Timing	49
2.9.1	Overview	49
2.9.2	On-Chip Memory Access Timing.....	49
2.9.3	On-Chip Supporting Module Access Timing	51
2.9.4	Access to External Address Space.....	52
Section 3	MCU Operating Modes.....	53
3.1	Overview	53
3.1.1	Operating Mode Selection	53
3.1.2	Register Configuration.....	54
3.2	Mode Control Register (MDCR)	55
3.3	System Control Register (SYSCR).....	56
3.4	Operating Mode Descriptions.....	58
3.4.1	Mode 1	58
3.4.2	Mode 3	58
3.5	Memory Map in Each Operating Mode.....	58
Section 4	Exception Handling.....	61
4.1	Overview	61
4.1.1	Exception Handling Types and Priority.....	61
4.1.2	Exception Handling Operation	61
4.1.3	Exception Vector Table	62
4.2	Reset	63
4.2.1	Overview.....	63
4.2.2	Reset Sequence	63
4.2.3	Interrupts after Reset.....	65
4.3	Interrupts	65
4.4	Trap Instruction.....	66
4.5	Stack Status after Exception Handling	66
4.6	Notes on Stack Usage	67
Section 5	Interrupt Controller.....	69
5.1	Overview	69
5.1.1	Features.....	69
5.1.2	Block Diagram.....	70
5.1.3	Pin Configuration.....	71
5.1.4	Register Configuration.....	71
5.2	Register Descriptions.....	72
5.2.1	System Control Register (SYSCR).....	72
5.2.2	Interrupt Priority Registers A and B (IPRA, IPRB)	73
5.2.3	IRQ Status Register (ISR)	79

5.2.4	IRQ Enable Register (IER)	80
5.2.5	IRQ Sense Control Register (ISCR)	81
5.3	Interrupt Sources	82
5.3.1	External Interrupts	82
5.3.2	Internal Interrupts	83
5.3.3	Interrupt Vector Table	83
5.4	Interrupt Operation	86
5.4.1	Interrupt Handling Process	86
5.4.2	Interrupt Sequence	91
5.4.3	Interrupt Response Time.....	92
5.5	Usage Notes	93
5.5.1	Contention between Interrupt and Interrupt-Disabling Instruction	93
5.5.2	Instructions that Inhibit Interrupts	94
5.5.3	Interrupts during EEPMOV Instruction Execution.....	94
Section 6	Bus Controller	95
6.1	Overview	95
6.1.1	Features.....	95
6.1.2	Block Diagram.....	96
6.1.3	Input/Output Pins.....	97
6.1.4	Register Configuration.....	97
6.2	Register Descriptions.....	98
6.2.1	Wait Control Register (WCR).....	98
6.2.2	Access State Control Register (ASTCR).....	99
6.2.3	Wait State Controller Enable Register (WCER).....	100
6.3	Operation	101
6.3.1	Area Division.....	101
6.3.2	Bus Control Signal Timing	103
6.3.3	Wait Modes	105
6.3.4	Interconnections with Memory (Example).....	111
6.4	Usage Notes	112
6.4.1	Register Write Timing	112
Section 7	I/O Ports	113
7.1	Overview	113
7.2	Port 6	115
7.2.1	Overview.....	115
7.2.2	Register Descriptions.....	115
7.2.3	Pin Functions	117
7.3	Port 7	118
7.3.1	Overview.....	118

	7.3.2	Register Description	119
7.4	Port 8	120
	7.4.1	Overview.....	120
	7.4.2	Register Descriptions.....	121
	7.4.3	Pin Functions	123
7.5	Port 9	124
	7.5.1	Overview.....	124
	7.5.2	Register Descriptions.....	124
	7.5.3	Pin Functions	126
7.6	Port A	127
	7.6.1	Overview.....	127
	7.6.2	Register Descriptions.....	128
	7.6.3	Pin Functions	130
7.7	Port B	137
	7.7.1	Overview.....	137
	7.7.2	Register Descriptions.....	137
	7.7.3	Pin Functions	139
Section 8 16-Bit Integrated Timer Unit (ITU).....			145
8.1	Overview	145
	8.1.1	Features.....	145
	8.1.2	Block Diagrams	148
	8.1.3	Input/Output Pins.....	153
	8.1.4	Register Configuration.....	154
8.2	Register Descriptions.....		157
	8.2.1	Timer Start Register (TSTR)	157
	8.2.2	Timer Synchro Register (TSNC)	158
	8.2.3	Timer Mode Register (TMDR).....	160
	8.2.4	Timer Function Control Register (TFCR)	163
	8.2.5	Timer Output Master Enable Register (TOER)	165
	8.2.6	Timer Output Control Register (TOCR).....	168
	8.2.7	Timer Counters (TCNT).....	169
	8.2.8	General Registers (GRA, GRB)	170
	8.2.9	Buffer Registers (BRA, BRB)	171
	8.2.10	Timer Control Registers (TCR).....	172
	8.2.11	Timer I/O Control Register (TIOR).....	174
	8.2.12	Timer Status Register (TSR).....	176
	8.2.13	Timer Interrupt Enable Register (TIER).....	179
8.3	CPU Interface		181
	8.3.1	16-Bit Accessible Registers.....	181
	8.3.2	8-Bit Accessible Registers	183

8.4	Operation	185
8.4.1	Overview.....	185
8.4.2	Basic Functions.....	186
8.4.3	Synchronization	196
8.4.4	PWM Mode	198
8.4.5	Reset-Synchronized PWM Mode	202
8.4.6	Complementary PWM Mode.....	205
8.4.7	Phase Counting Mode.....	215
8.4.8	Buffering.....	217
8.4.9	ITU Output Timing.....	224
8.5	Interrupts	226
8.5.1	Setting of Status Flags	226
8.5.2	Clearing of Status Flags.....	228
8.5.3	Interrupt Sources.....	229
8.6	Usage Notes.....	230
Section 9 Watchdog Timer		245
9.1	Overview	245
9.1.1	Features.....	245
9.1.2	Block Diagram.....	246
9.1.3	Pin Configuration.....	246
9.1.4	Register Configuration.....	247
9.2	Register Descriptions.....	248
9.2.1	Timer Counter (TCNT).....	248
9.2.2	Timer Control/Status Register (TCSR).....	249
9.2.3	Reset Control/Status Register (RSTCSR)	251
9.2.4	Notes on Register Access	253
9.3	Operation	255
9.3.1	Watchdog Timer Operation.....	255
9.3.2	Interval Timer Operation	256
9.3.3	Timing of Setting of Overflow Flag (OVF).....	257
9.3.4	Timing of Setting of Watchdog Timer Reset Bit (WRST)	258
9.4	Interrupts	259
9.5	Usage Notes.....	259
Section 10 Serial Communication Interface.....		261
10.1	Overview	261
10.1.1	Features.....	261
10.1.2	Block Diagram.....	263
10.1.3	Input/Output Pins.....	264
10.1.4	Register Configuration.....	264

10.2	Register Descriptions	265
10.2.1	Receive Shift Register (RSR)	265
10.2.2	Receive Data Register (RDR)	265
10.2.3	Transmit Shift Register (TSR)	266
10.2.4	Transmit Data Register (TDR)	266
10.2.5	Serial Mode Register (SMR)	267
10.2.6	Serial Control Register (SCR)	271
10.2.7	Serial Status Register (SSR)	275
10.2.8	Bit Rate Register (BRR)	279
10.3	Operation	288
10.3.1	Overview	288
10.3.2	Operation in Asynchronous Mode	290
10.3.3	Multiprocessor Communication	299
10.3.4	Synchronous Operation	306
10.4	SCI Interrupts	315
10.5	Usage Notes	316
Section 11	A/D Converter	321
11.1	Overview	321
11.1.1	Features	321
11.1.2	Block Diagram	322
11.1.3	Input Pins	323
11.1.4	Register Configuration	324
11.2	Register Descriptions	325
11.2.1	A/D Data Registers A to D (ADDRA to ADDR D)	325
11.2.2	A/D Control/Status Register (ADCSR)	326
11.2.3	A/D Control Register (ADCR)	329
11.3	CPU Interface	330
11.4	Operation	331
11.4.1	Single Mode (SCAN = 0)	331
11.4.2	Scan Mode (SCAN = 1)	333
11.4.3	Input Sampling and A/D Conversion Time	335
11.4.4	External Trigger Input Timing	336
11.5	Interrupts	337
11.6	Usage Notes	337
Section 12	RAM	339
12.1	Overview	339
12.1.1	Block Diagram	339
12.1.2	Register Configuration	340
12.2	System Control Register (SYSCR)	341

12.3	Operation	342
Section 13	Clock Pulse Generator	343
13.1	Overview	343
13.1.1	Block Diagram.....	343
13.2	Oscillator Circuit	344
13.2.1	Connecting a Crystal Resonator	344
13.2.2	External Clock Input.....	346
13.3	Duty Adjustment Circuit.....	348
13.4	Prescalers	348
Section 14	Power-Down State	349
14.1	Overview	349
14.2	Register Configuration.....	350
14.2.1	System Control Register (SYSCR).....	350
14.3	Sleep Mode	352
14.3.1	Transition to Sleep Mode.....	352
14.3.2	Exit from Sleep Mode.....	352
14.4	Software Standby Mode	353
14.4.1	Transition to Software Standby Mode	353
14.4.2	Exit from Software Standby Mode	353
14.4.3	Selection of Waiting Time for Exit from Software Standby Mode	354
14.4.4	Sample Application of Software Standby Mode	355
14.4.5	Note.....	355
14.5	Hardware Standby Mode	356
14.5.1	Transition to Hardware Standby Mode.....	356
14.5.2	Exit from Hardware Standby Mode.....	356
14.5.3	Timing for Hardware Standby Mode.....	356
Section 15	Electrical Characteristics	357
15.1	Absolute Maximum Ratings	357
15.2	Electrical Characteristics	358
15.2.1	DC Characteristics	358
15.2.2	AC Characteristics	368
15.2.3	A/D Conversion Characteristics	375
15.3	Operational Timing.....	376
15.3.1	Bus Timing	376
15.3.2	Control Signal Timing	380
15.3.3	Clock Timing	382
15.3.4	I/O Port Timing.....	382
15.3.5	ITU Timing	383

15.3.6	SCI Input/Output Timing.....	384
Appendix A Instruction Set..... 385		
A.1	Instruction List.....	385
A.2	Operation Code Maps.....	400
A.3	Number of States Required for Execution.....	403
Appendix B Register Field..... 412		
B.1	Register Addresses and Bit Names.....	412
B.2	Register Descriptions.....	420
Appendix C I/O Port Block Diagrams..... 461		
C.1	Port 6 Block Diagram.....	461
C.2	Port 7 Block Diagram.....	462
C.3	Port 8 Block Diagram.....	463
C.4	Port 9 Block Diagram.....	465
C.5	Port A Block Diagram.....	468
C.6	Port B Block Diagram.....	471
Appendix D Pin States..... 475		
D.1	Port States in Each Mode.....	475
D.2	Pin States at Reset.....	476
Appendix E Timing of Transition to and Recovery from Hardware Standby Mode..... 479		
Appendix F Product Code Lineup..... 480		
Appendix G Package Dimensions..... 481		

Section 1 Overview

1.1 Overview

The H8/3004 and H8/3005 are microcontrollers (MCUs) that integrate system supporting functions together with an H8/300H CPU core having an original Hitachi architecture.

The H8/300H CPU has a 32-bit internal architecture with sixteen 16-bit general registers, and a concise, optimized instruction set designed for speed. It can address a 16-Mbyte linear address space. Its instruction set is upward-compatible at the object-code level with the H8/300 CPU, enabling easy porting of software from the H8/300 Series.

The on-chip system supporting functions include RAM, a 16-bit integrated timer unit (ITU), a watchdog timer (WDT), a serial communication interface (SCI), an A/D converter, I/O ports, and other facilities.

Two MCU operating modes—modes 1 and 3—offer a choice of address space size.

Table 1-1 summarizes the features of the H8/3004 and H8/3005.

Table 1-1 Features

Feature	Description
CPU	<p>Upward-compatible with the H8/300 CPU at the object-code level</p> <p>General-register machine</p> <ul style="list-style-type: none"> • Sixteen 16-bit general registers (also useable as sixteen 8-bit registers or eight 32-bit registers) <p>High-speed operation</p> <ul style="list-style-type: none"> • Maximum clock rate: 16 MHz • Add/subtract: 125 ns • Multiply/divide: 875 ns <p>Two CPU operating modes</p> <ul style="list-style-type: none"> • Normal mode (64-kbyte address space; cannot be used with the H8/3004 or H8/3005) • Advanced mode (16-Mbyte address space) <p>Instruction features</p> <ul style="list-style-type: none"> • 8/16/32-bit data transfer, arithmetic, and logic instructions • Signed and unsigned multiply instructions (8 bits \times 8 bits, 16 bits \times 16 bits) • Signed and unsigned divide instructions (16 bits \div 8 bits, 32 bits \div 16 bits) • Bit accumulator function • Bit manipulation instructions with register-indirect specification of bit positions
Memory	<ul style="list-style-type: none"> • H8/3004 RAM: 2 kbyte, H8/3005 RAM: 4 kbyte
Interrupt controller	<ul style="list-style-type: none"> • Six external interrupt pins: NMI, $\overline{\text{IRQ}}_0$ to $\overline{\text{IRQ}}_4$ • 21 internal interrupts • Three selectable interrupt priority levels
Bus controller	<ul style="list-style-type: none"> • Address space can be partitioned into eight areas, with independent bus specifications in each area • Two-state or three-state access selectable for each area • Selection of four wait modes • Bus arbitration function
16-bit integrated timer unit (ITU)	<ul style="list-style-type: none"> • Five 16-bit timer channels, capable of processing up to 12 pulse outputs or 10 pulse inputs • 16-bit timer counter (channels 0 to 4) • Two multiplexed output compare/input capture pins (channels 0 to 4) • Operation can be synchronized (channels 0 to 4) • PWM mode available (channels 0 to 4) • Phase counting mode available (channel 2) • Buffering available (channels 3 and 4) • Reset-synchronized PWM mode available (channels 3 and 4) • Complementary PWM mode available (channels 3 and 4)

Table 1-1 Features (cont)

Feature	Description																											
Watchdog timer (WDT), 1 channel	<ul style="list-style-type: none"> • Reset signal can be generated by overflow • Reset signal can be output externally • Usable as an interval timer 																											
Serial communication interface (SCI), 1 channel	<ul style="list-style-type: none"> • Selection of asynchronous or synchronous mode • Full duplex: can transmit and receive simultaneously • On-chip baud-rate generator 																											
A/D converter	<ul style="list-style-type: none"> • Resolution: 10 bits • Eight channels, with selection of single or scan mode • Variable analog conversion voltage range • Sample-and-hold function • Can be externally triggered 																											
I/O ports	<ul style="list-style-type: none"> • 21 input/output pins • 11 input-only pins 																											
Operating modes	Two MCU operating modes																											
	<table border="1"> <thead> <tr> <th>Mode</th> <th>Address Space</th> <th>Address Pins</th> </tr> </thead> <tbody> <tr> <td>Mode 1</td> <td>1 Mbyte</td> <td>A₀ to A₁₉</td> </tr> <tr> <td>Mode 3</td> <td>16 Mbyte</td> <td>A₀to A₂₃</td> </tr> </tbody> </table>	Mode	Address Space	Address Pins	Mode 1	1 Mbyte	A ₀ to A ₁₉	Mode 3	16 Mbyte	A ₀ to A ₂₃																		
Mode	Address Space	Address Pins																										
Mode 1	1 Mbyte	A ₀ to A ₁₉																										
Mode 3	16 Mbyte	A ₀ to A ₂₃																										
Power-down state	<ul style="list-style-type: none"> • Sleep mode • Software standby mode • Hardware standby mode 																											
Other features	<ul style="list-style-type: none"> • On-chip clock oscillator 																											
Product lineup	<table border="1"> <thead> <tr> <th>Model</th> <th>Package</th> <th>Power Supply Voltage</th> </tr> </thead> <tbody> <tr> <td>HD6413004F</td> <td>80-pin QFP (FP-80A)</td> <td>5 V ±10%</td> </tr> <tr> <td>HD6413004VF</td> <td></td> <td>2.7 to 5.5 V</td> </tr> <tr> <td>HD6413004TE</td> <td>80-pin TQFP (TFP-80C)</td> <td>5 V ±10%</td> </tr> <tr> <td>HD6413004VTE</td> <td></td> <td>2.7 V to 5.5 V</td> </tr> <tr> <td>HD6413005F</td> <td>80-pin QFP (FP-80A)</td> <td>5 V ±10%</td> </tr> <tr> <td>HD6413005VF</td> <td></td> <td>2.7 V to 5.5 V</td> </tr> <tr> <td>HD6413005TE</td> <td>80-pin TQFP (TFP-80C)</td> <td>5 V ±10%</td> </tr> <tr> <td>HD6413005VTE</td> <td></td> <td>2.7 V to 5.5 V</td> </tr> </tbody> </table>	Model	Package	Power Supply Voltage	HD6413004F	80-pin QFP (FP-80A)	5 V ±10%	HD6413004VF		2.7 to 5.5 V	HD6413004TE	80-pin TQFP (TFP-80C)	5 V ±10%	HD6413004VTE		2.7 V to 5.5 V	HD6413005F	80-pin QFP (FP-80A)	5 V ±10%	HD6413005VF		2.7 V to 5.5 V	HD6413005TE	80-pin TQFP (TFP-80C)	5 V ±10%	HD6413005VTE		2.7 V to 5.5 V
Model	Package	Power Supply Voltage																										
HD6413004F	80-pin QFP (FP-80A)	5 V ±10%																										
HD6413004VF		2.7 to 5.5 V																										
HD6413004TE	80-pin TQFP (TFP-80C)	5 V ±10%																										
HD6413004VTE		2.7 V to 5.5 V																										
HD6413005F	80-pin QFP (FP-80A)	5 V ±10%																										
HD6413005VF		2.7 V to 5.5 V																										
HD6413005TE	80-pin TQFP (TFP-80C)	5 V ±10%																										
HD6413005VTE		2.7 V to 5.5 V																										

1.2 Block Diagram

Figure 1-1 shows an internal block diagram.

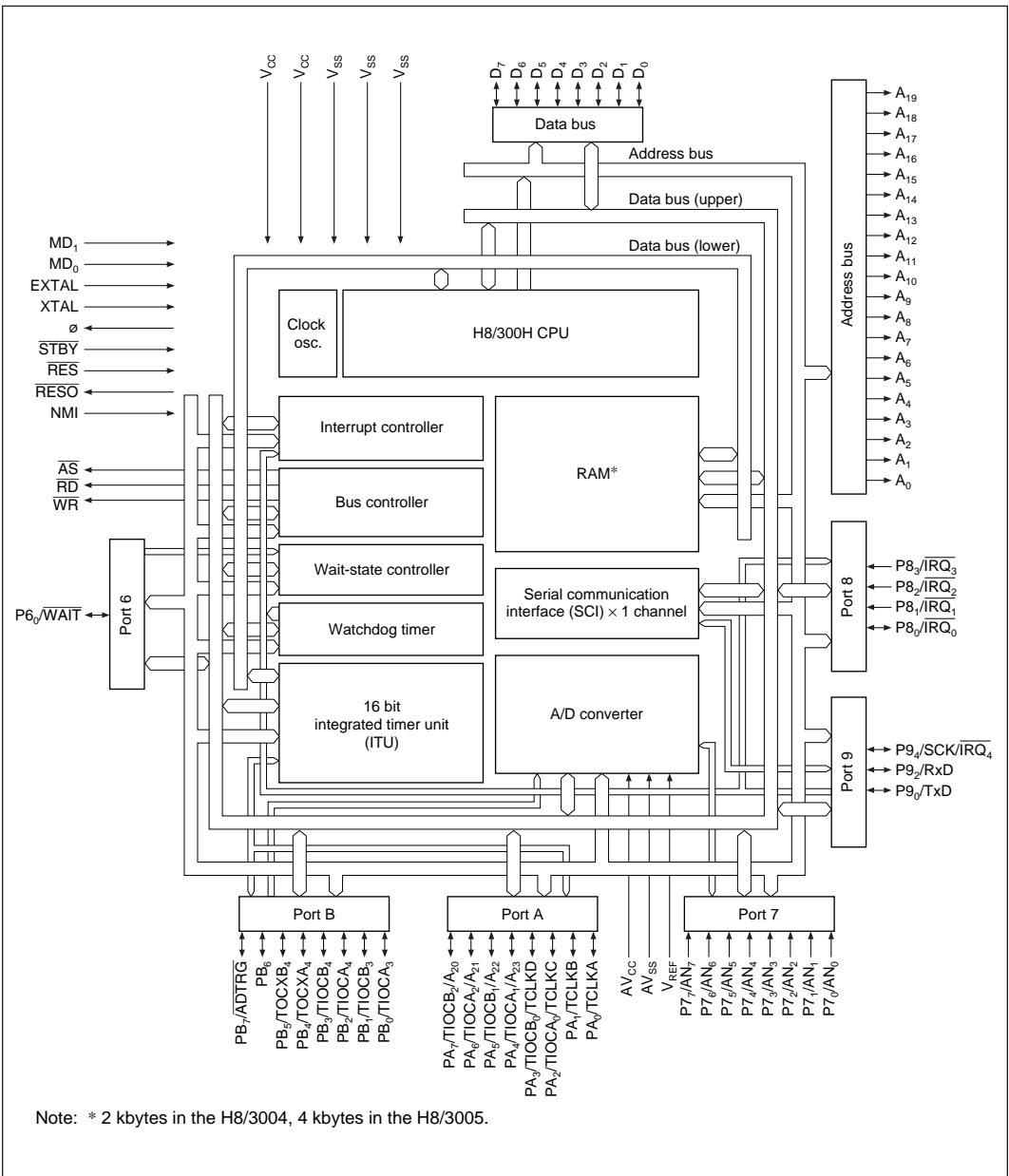

Figure 1-1 Block Diagram

1.3 Pin Description

1.3.1 Pin Arrangement

Figure 1-2 shows the pin arrangement of the H8/3004 and H8/3005, FP-80A and TFP-80C package.

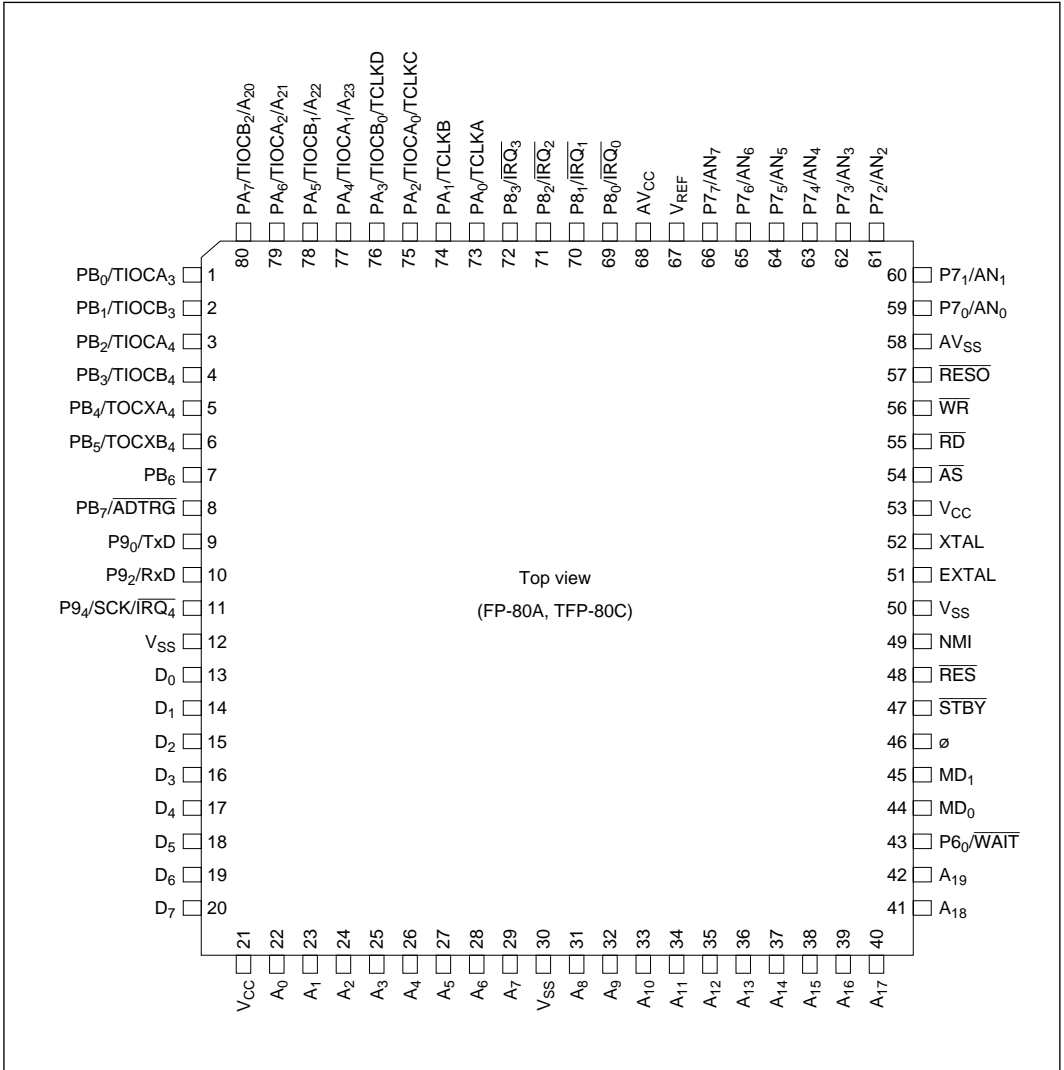

Figure 1-2 Pin Arrangement (FP-80A, TFP-80C, Top View)

1.3.2 Pin Functions

Pin Assignments in Each Mode: Table 1-2 lists the FP-80A and TFP-80C pin assignments in each mode.

Table 1-2 FP-80A and TFP-80C Pin Assignments in Each Mode

Pin No.	Pin Name	
	Mode 1	Mode 3
1	PB ₀ /TIOCA ₃	PB ₀ /TIOCA ₃
2	PB ₁ /TIOCB ₃	PB ₁ /TIOCB ₃
3	PB ₂ /TIOCA ₄	PB ₂ /TIOCA ₄
4	PB ₃ /TIOCB ₄	PB ₃ /TIOCB ₄
5	PB ₄ /TOCXA ₄	PB ₄ /TOCXA ₄
6	PB ₅ /TOCXB ₄	PB ₅ /TOCXB ₄
7	PB ₆	PB ₆
8	PB ₇ /ADTRG	PB ₇ /ADTRG
9	P9 ₀ /TxD	P9 ₀ /TxD
10	P9 ₂ /RxD	P9 ₂ /RxD
11	P9 ₄ /SCK/IRQ ₄	P9 ₄ /SCK/IRQ ₄
12	V _{SS}	V _{SS}
13	D ₀	D ₀
14	D ₁	D ₁
15	D ₂	D ₂
16	D ₃	D ₃
17	D ₄	D ₄
18	D ₅	D ₅
19	D ₆	D ₆
20	D ₇	D ₇
21	V _{CC}	V _{CC}
22	A ₀	A ₀
23	A ₁	A ₁
24	A ₂	A ₂
25	A ₃	A ₃

Table 1-2 FP-80A and TFP-80C Pin Assignments in Each Mode (cont)

Pin No.	Pin Name	
	Mode 1	Mode 3
26	A ₄	A ₄
27	A ₅	A ₅
28	A ₆	A ₆
29	A ₇	A ₇
30	V _{SS}	V _{SS}
31	A ₈	A ₈
32	A ₉	A ₉
33	A ₁₀	A ₁₀
34	A ₁₁	A ₁₁
35	A ₁₂	A ₁₂
36	A ₁₃	A ₁₃
37	A ₁₄	A ₁₄
38	A ₁₅	A ₁₅
39	A ₁₆	A ₁₆
40	A ₁₇	A ₁₇
41	A ₁₈	A ₁₈
42	A ₁₉	A ₁₉
43	P6 ₀ $\overline{\text{WAIT}}$	P6 ₀ $\overline{\text{WAIT}}$
44	MD ₀	MD ₀
45	MD ₁	MD ₁
46	∅	∅
47	$\overline{\text{STBY}}$	$\overline{\text{STBY}}$
48	$\overline{\text{RES}}$	$\overline{\text{RES}}$
49	NMI	NMI
50	V _{SS}	V _{SS}
51	EXTAL	EXTAL
52	XTAL	XTAL
53	V _{CC}	V _{CC}

Table 1-2 FP-80A and TFP-80C Pin Assignments in Each Mode (cont)

Pin No.	Pin Name	
	Mode 1	Mode 3
54	\overline{AS}	\overline{AS}
55	\overline{RD}	\overline{RD}
56	\overline{WR}	\overline{WR}
57	\overline{RESO}	\overline{RESO}
58	AV_{SS}	AV_{SS}
59	$P7_0/AN_0$	$P7_0/AN_0$
60	$P7_1/AN_1$	$P7_1/AN_1$
61	$P7_2/AN_2$	$P7_2/AN_2$
62	$P7_3/AN_3$	$P7_3/AN_3$
63	$P7_4/AN_4$	$P7_4/AN_4$
64	$P7_5/AN_5$	$P7_5/AN_5$
65	$P7_6/AN_6$	$P7_6/AN_6$
66	$P7_7/AN_7$	$P7_7/AN_7$
67	V_{REF}	V_{REF}
68	AV_{CC}	AV_{CC}
69	$P8_0/\overline{IRQ}_0$	$P8_0/\overline{IRQ}_0$
70	$P8_1/\overline{IRQ}_1$	$P8_1/\overline{IRQ}_1$
71	$P8_2/\overline{IRQ}_2$	$P8_2/\overline{IRQ}_2$
72	$P8_3/\overline{IRQ}_3$	$P8_3/\overline{IRQ}_3$
73	$PA_0/TCLKA$	$PA_0/TCLKA$
74	$PA_1/TCLKB$	$PA_1/TCLKB$
75	$PA_2/TIOCA_0/TCLKC$	$PA_2/TIOCA_0/TCLKC$
76	$PA_3/TIOCB_0/TCLKD$	$PA_3/TIOCB_0/TCLKD$
77	$PA_4/TIOCA_1$	A_{23}
78	$PA_5/TIOCB_1$	A_{22}
79	$PA_6/TIOCA_2$	A_{21}
80	$PA_7/TIOCB_2$	A_{20}

1.4 Pin Functions

Table 1-3 summarizes the pin functions.

Table 1-3 Pin Functions

Type	Symbol	Pin No.	I/O	Name and Function															
Power	V_{CC}	21, 53	Input	Power: For connection to the power supply (+5 V). Connect all V_{CC} pins to the +5-V system power supply.															
	V_{SS}	12, 30, 50	Input	Ground: For connection to ground (0 V). Connect all V_{SS} pins to the 0-V system power supply.															
Clock	XTAL	52	Input	For connection to a crystal resonator. For examples of crystal resonator and external clock input, see section 13, Clock Pulse Generator.															
	EXTAL	51	Input	For connection to a crystal resonator or input of an external clock signal. For examples of crystal resonator and external clock input, see section 13, Clock Pulse Generator.															
	\emptyset	46	Output	System clock: Supplies the system clock to external devices															
Operating mode control	MD ₁ , MD ₀	44, 45	Input	Mode 1 and mode 0: For setting the operating mode, as follows															
				<table border="1"> <thead> <tr> <th>MD₁</th> <th>MD₀</th> <th>Operating Mode</th> </tr> </thead> <tbody> <tr> <td>0</td> <td>0</td> <td>—</td> </tr> <tr> <td>0</td> <td>1</td> <td>Mode 1</td> </tr> <tr> <td>1</td> <td>0</td> <td>—</td> </tr> <tr> <td>1</td> <td>1</td> <td>Mode 3</td> </tr> </tbody> </table>	MD ₁	MD ₀	Operating Mode	0	0	—	0	1	Mode 1	1	0	—	1	1	Mode 3
	MD ₁	MD ₀	Operating Mode																
	0	0	—																
	0	1	Mode 1																
1	0	—																	
1	1	Mode 3																	
System control	\overline{RES}	48	Input	Reset input: When driven low, this pin resets the H8/3004 or H8/3005															
	\overline{RESO}	57	Output	Reset output: Outputs a reset signal to external devices															
	\overline{STBY}	47	Input	Standby: When driven low, this pin forces a transition to hardware standby mode															

Table 1-3 Pin Functions (cont)

Type	Symbol	Pin No.	I/O	Name and Function
Interrupts	NMI	49	Input	Nonmaskable interrupt: Requests a nonmaskable interrupt
	IRQ ₄ to IRQ ₀	11, 72 to 69	Input	Interrupt request 4 to 0: Maskable interrupt request pins
Ad- dress bus	Mode 1 A ₁₉ to A ₀	22 to 29 31 to 42	Output	Address bus: Outputs address signals
	Mode 3 A ₂₃ to A ₀	80 to 77 22 to 29 31 to 42		
Data bus	D ₇ to D ₀	20 to 13	Input/ output	Data bus: Bidirectional data bus
Bus control	\overline{AS}	54	Output	Address strobe: Goes low to indicate valid address output on the address bus
	\overline{RD}	55	Output	Read: Goes low to indicate reading from the external address space
	\overline{WR}	56	Output	High write: Goes low to indicate writing to the external address space; indicates valid data on the upper half of the data bus (D ₇ to D ₀).
	\overline{WAIT}	43	Input	Wait: Requests insertion of wait states in bus cycles during access to the external address space
16-bit integrated time unit (ITU)	TCLKD to TCLKA	76 to 73	Input	Clock input A to D: External clock inputs
	TIOCA ₄ to TIOCA ₀	3, 1, 79, 77, 75	Input/ output	Input capture/output compare A4 to A0: GRA4 to GRA0 output compare or input capture, or PWM output
	TIOCB ₄ to TIOCB ₀	4, 2, 80, 78, 76	Input/ output	Input capture/output compare B4 to B0: GRB4 to GRB0 output compare or input capture, or PWM output
	TOCXA ₄	5	Output	Output compare XA4: PWM output
	TOCXB ₄	6	Output	Output compare XB4: PWM output

Table 1-3 Pin Functions (cont)

Type	Symbol	Pin No.	I/O	Name and Function
Serial communication interface (SCI)	TxD	9	Output	Transmit data: SCI data output
	RxD	10	Input	Receive data: SCI data input
	SCK	11	Input/output	Serial clock: SCI clock input/output
A/D converter	AN ₇ to AN ₀	66 to 59	Input	Analog 7 to 0: Analog input pins
	ADTRG	8	Input	A/D trigger: External trigger input for starting A/D conversion
	AV _{CC}	68	Input	Power supply pin for the A/D converter. Connect to the system power supply (+5 V) when not using the A/D converter.
	AV _{SS}	58	Input	Ground pin for the A/D converter. Connect to system ground (0 V) when not using the A/D converter.
	V _{REF}	67	Input	Reference voltage input pin for the A/D converter. Connect to the system power supply (+5 V) when not using the A/D converter.
I/O ports	P6 ₀	43	Input/output	Port 6: One input/output pins. The direction of each pin can be selected in the port 6 data direction register (P6DDR).
	P7 ₇ to P7 ₀	66 to 59	Input	Port 7: Eight input pins
	P8 ₃ to P8 ₁	72 to 70	Input	Port 8: Three input pins. Do not designate these pins as output pins in the port 8 data direction register (P8DDR).
	P8 ₀	69	Input/output	Port 8: One input/output pin. The direction of the pin can be selected in the port 8 ₀ data direction register (P8 ₀ DDR).
	P9 ₄ , P9 ₂ , P9 ₀	11 to 9	Input/output	Port 9: Three input/output pins. The direction of each pin can be selected in the port 9 data direction register (P9DDR).
	PA ₇ to PA ₀	80 to 73	Input/output	Port A: Eight input/output pins. The direction of each pin can be selected in the port A data direction register (PADDDR).
	PB ₇ to PB ₀	8 to 1	Input/output	Port B: Eight input/output pins. The direction of each pin can be selected in the port B data direction register (PBDDR).

Section 2 CPU

2.1 Overview

The H8/300H CPU is a high-speed central processing unit with an internal 32-bit architecture that is upward-compatible with the H8/300 CPU. The H8/300H CPU has sixteen 16-bit general registers, can address a 16-Mbyte linear address space, and is ideal for realtime control.

2.1.1 Features

The H8/300H CPU has the following features.

- Upward compatibility with H8/300 CPU
 - Can execute H8/300 series object programs without alteration
- General-register architecture
 - Sixteen 16-bit general registers (also usable as sixteen 8-bit registers or eight 32-bit registers)
- Sixty-two basic instructions
 - 8/16/32-bit arithmetic and logic instructions
 - Multiply and divide instructions
 - Powerful bit-manipulation instructions
- Eight addressing modes
 - Register direct [Rn]
 - Register indirect [$@ERn$]
 - Register indirect with displacement [$@(d:16, ERn)$ or $@(d:24, ERn)$]
 - Register indirect with post-increment or pre-decrement [$@ERn+$ or $@-ERn$]
 - Absolute address [$@aa:8$, $@aa:16$, or $@aa:24$]
 - Immediate [$\#xx:8$, $\#xx:16$, or $\#xx:32$]
 - Program-counter relative [$@(d:8, PC)$ or $@(d:16, PC)$]
 - Memory indirect [$@@aa:8$]
- 16-Mbyte linear address space

- High-speed operation
 - All frequently-used instructions execute in two to four states
 - Maximum clock frequency: 16 MHz
 - 8/16/32-bit register-register add/subtract: 125 ns
 - 8 ×8-bit register-register multiply: 875 ns
 - 16 ÷ 8-bit register-register divide: 875 ns
 - 16 ×16-bit register-register multiply: 1.375 μs
 - 32 ÷ 16-bit register-register divide: 1.375 μs
- Two CPU operating modes
 - Normal mode (Cannot be used with the H8/3004 or H8/3005.)
 - Advanced mode

- Low-power mode

Transition to power-down state by SLEEP instruction

2.1.2 Differences from H8/300 CPU

In comparison to the H8/300 CPU, the H8/300H has the following enhancements.

- More general registers
 - Eight 16-bit registers have been added.
- Expanded address space
 - Advanced mode supports a maximum 16-Mbyte address space.
 - Normal mode supports the same 64-kbyte address space as the H8/300 CPU. (Cannot be used with the H8/3004 or H8/3005.)
- Enhanced addressing
 - The addressing modes have been enhanced to make effective use of the 16-Mbyte address space.
- Enhanced instructions
 - Data transfer, arithmetic, and logic instructions can operate on 32-bit data.
 - Signed multiply/divide instructions and other instructions have been added.

2.2 CPU Operating Modes

The H8/300H CPU has two operating modes: normal and advanced. Normal mode supports a maximum 64-kbyte address space. Advanced mode supports up to 16 Mbytes. See figure 2-1. The H8/3004 and H8/3005 can only be used in advanced mode.

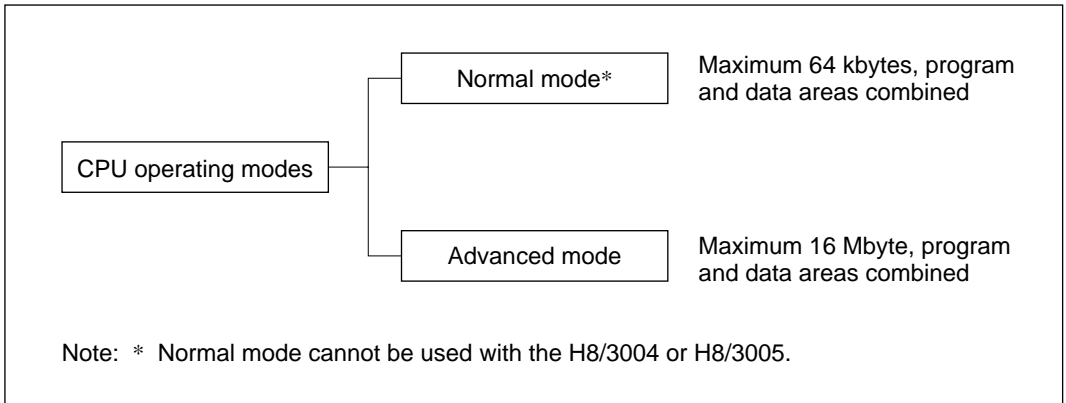

Figure 2-1 CPU Operating Modes

2.3 Address Space

The H8/300H CPU can address a linear address space with a maximum size of 16 Mbytes. 1-Mbyte mode or 16-Mbyte mode can be selected for the H8/300H address space, according to the MCU operating mode. An outline memory map for the H8/3004 and H8/3005 is shown in figure 2-2. For further details see section 3.5, Memory Map in Each Operating Mode.

The 1-Mbyte operating mode uses 20-bit addressing. The upper 4 bits of effective addresses are ignored.

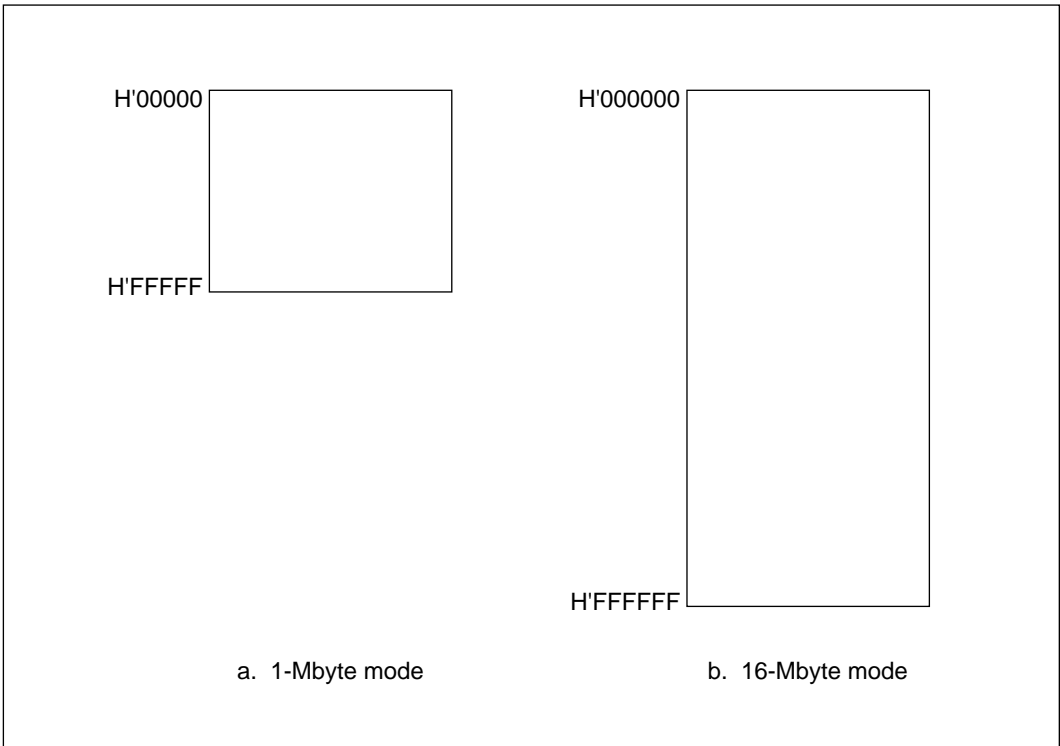

Figure 2-2 Memory Map

2.4 Register Configuration

2.4.1 Overview

The H8/300H CPU has the internal registers shown in figure 2-3. There are two types of registers: general registers and control registers.

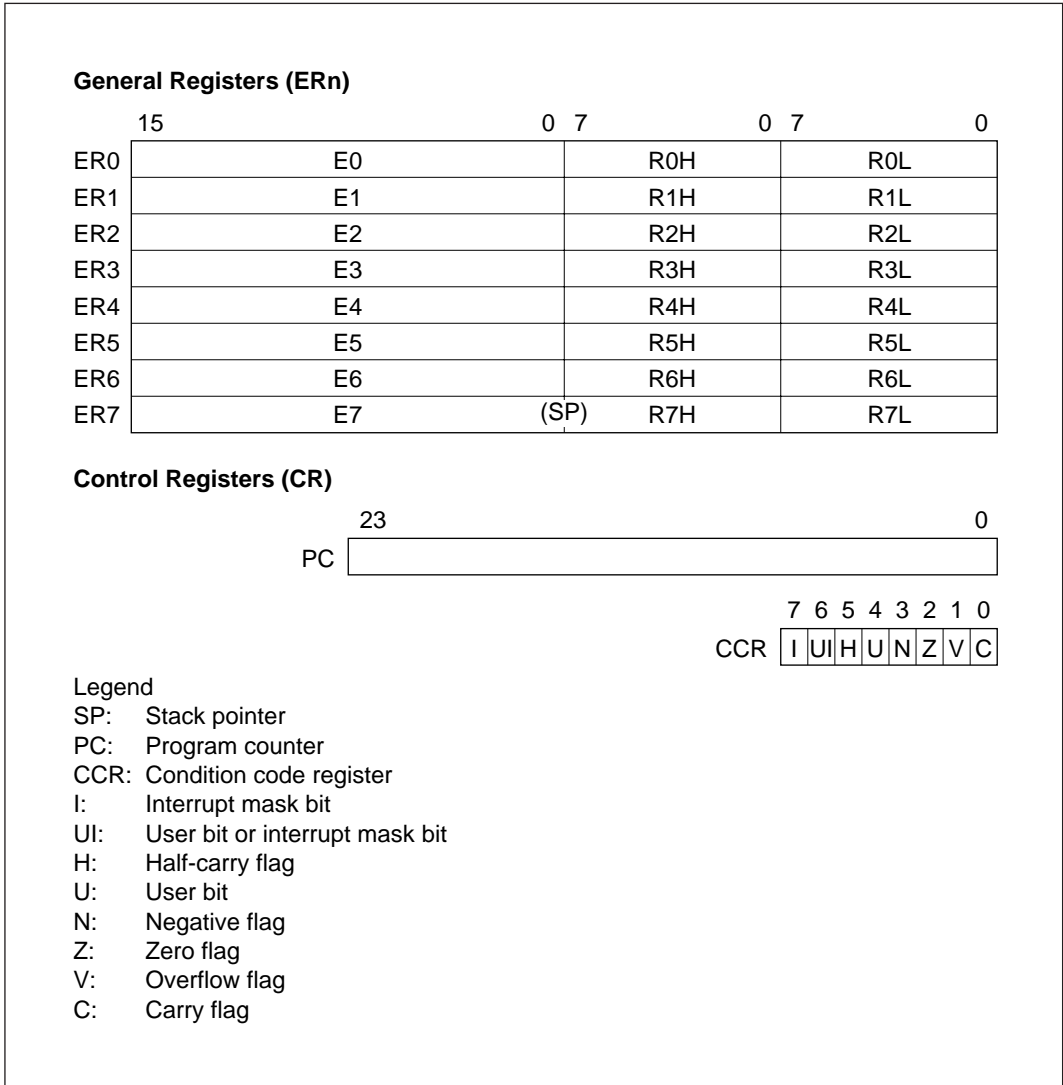

Figure 2-3 CPU Registers

2.4.2 General Registers

The H8/300H CPU has eight 32-bit general registers. These general registers are all functionally alike and can be used without distinction between data registers and address registers. When a general register is used as a data register, it can be accessed as a 32-bit, 16-bit, or 8-bit register. When the general registers are used as 32-bit registers or as address registers, they are designated by the letters ER (ER0 to ER7).

The ER registers divide into 16-bit general registers designated by the letters E (E0 to E7) and R (R0 to R7). These registers are functionally equivalent, providing a maximum sixteen 16-bit registers. The E registers (E0 to E7) are also referred to as extended registers.

The R registers divide into 8-bit general registers designated by the letters RH (R0H to R7H) and RL (R0L to R7L). These registers are functionally equivalent, providing a maximum sixteen 8-bit registers.

Figure 2-4 illustrates the usage of the general registers. The usage of each register can be selected independently.

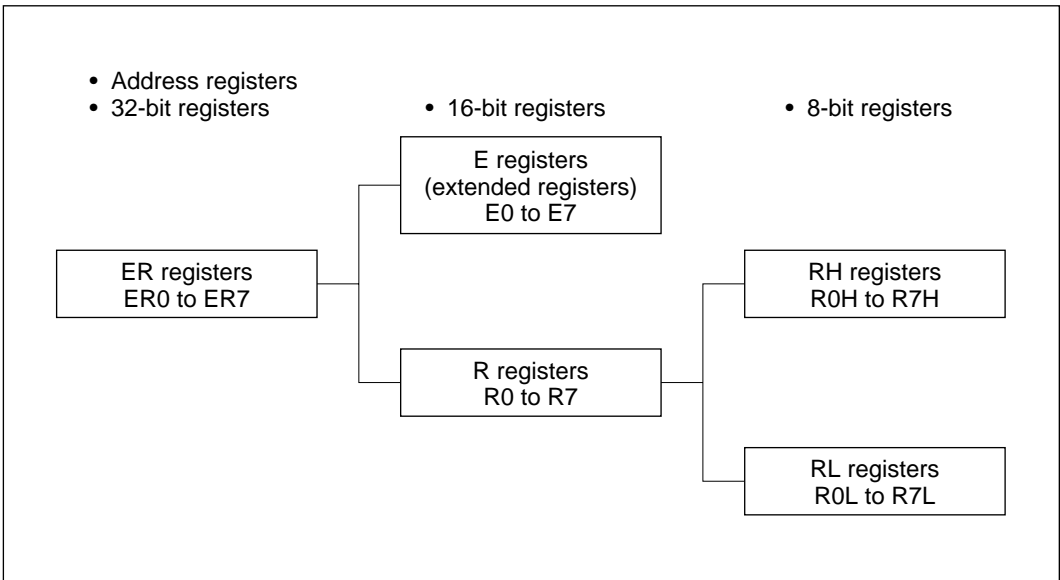

Figure 2-4 Usage of General Registers

General register ER7 has the function of stack pointer (SP) in addition to its general-register function, and is used implicitly in exception handling and subroutine calls. Figure 2-5 shows the stack.

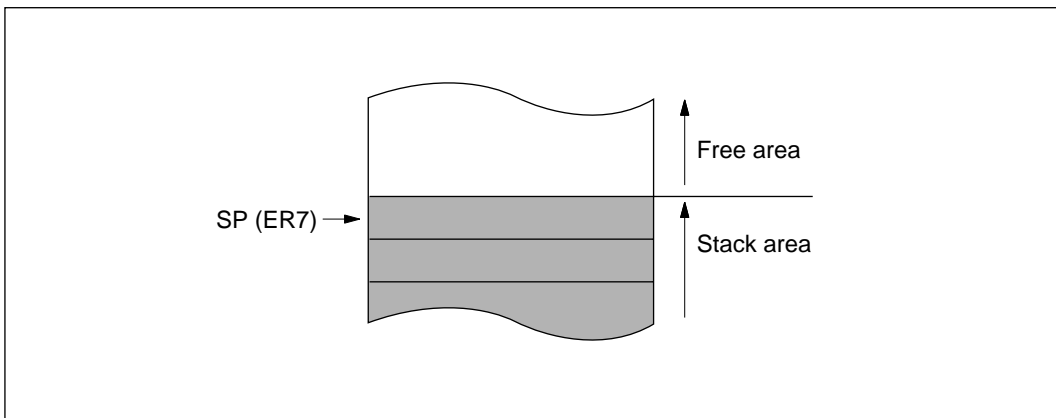

Figure 2-5 Stack

2.4.3 Control Registers

The control registers are the 24-bit program counter (PC) and the 8-bit condition code register (CCR).

Program Counter (PC): This 24-bit counter indicates the address of the next instruction the CPU will execute. The length of all CPU instructions is 2 bytes (one word) or a multiple of 2 bytes, so the least significant PC bit is ignored. When an instruction is fetched, the least significant PC bit is regarded as 0.

Condition Code Register (CCR): This 8-bit register contains internal CPU status information, including the interrupt mask bit (I) and half-carry (H), negative (N), zero (Z), overflow (V), and carry (C) flags.

Bit 7—Interrupt Mask Bit (I): Masks interrupts other than NMI when set to 1. NMI is accepted regardless of the I bit setting. The I bit is set to 1 at the start of an exception-handling sequence.

Bit 6—User Bit or Interrupt Mask Bit (UI): Can be written and read by software using the LDC, STC, ANDC, ORC, and XORC instructions. This bit can also be used as an interrupt mask bit. For details see section 5, Interrupt Controller.

Bit 5—Half-Carry Flag (H): When the ADD.B, ADDX.B, SUB.B, SUBX.B, CMP.B, or NEG.B instruction is executed, this flag is set to 1 if there is a carry or borrow at bit 3, and cleared to 0 otherwise. When the ADD.W, SUB.W, CMP.W, or NEG.W instruction is executed, the H flag is set to 1 if there is a carry or borrow at bit 11, and cleared to 0 otherwise. When the ADD.L, SUB.L, CML.L, or NEG.L instruction is executed, the H flag is set to 1 if there is a carry or borrow at bit 27, and cleared to 0 otherwise.

Bit 4—User Bit (U): Can be written and read by software using the LDC, STC, ANDC, ORC, and XORC instructions.

Bit 3—Negative Flag (N): Indicates the most significant bit (sign bit) of data.

Bit 2—Zero Flag (Z): Set to 1 to indicate zero data, and cleared to 0 to indicate non-zero data.

Bit 1—Overflow Flag (V): Set to 1 when an arithmetic overflow occurs, and cleared to 0 at other times.

Bit 0—Carry Flag (C): Set to 1 when a carry occurs, and cleared to 0 otherwise. Used by:

- Add instructions, to indicate a carry
- Subtract instructions, to indicate a borrow
- Shift and rotate instructions, to store the value shifted out of the end bit

The carry flag is also used as a bit accumulator by bit manipulation instructions.

Some instructions leave flag bits unchanged. Operations can be performed on CCR by the LDC, STC, ANDC, ORC, and XORC instructions. The N, Z, V, and C flags are used by conditional branch (Bcc) instructions.

For the action of each instruction on the flag bits, see appendix A.1, Instruction List. For the I and UI bits, see section 5, Interrupt Controller.

2.4.4 Initial CPU Register Values

In reset exception handling, PC is initialized to a value loaded from the vector table, and the I bit in CCR is set to 1. The other CCR bits and the general registers are not initialized. In particular, the stack pointer (ER7) is not initialized. The stack pointer must therefore be initialized by an MOV.L instruction executed immediately after a reset.

2.5 Data Formats

The H8/300H CPU can process 1-bit, 4-bit (BCD), 8-bit (byte), 16-bit (word), and 32-bit (longword) data. Bit-manipulation instructions operate on 1-bit data by accessing bit n ($n = 0, 1, 2, \dots, 7$) of byte operand data. The DAA and DAS decimal-adjust instructions treat byte data as two digits of 4-bit BCD data.

2.5.1 General Register Data Formats

Figures 2-6 and 2-7 show the data formats in general registers.

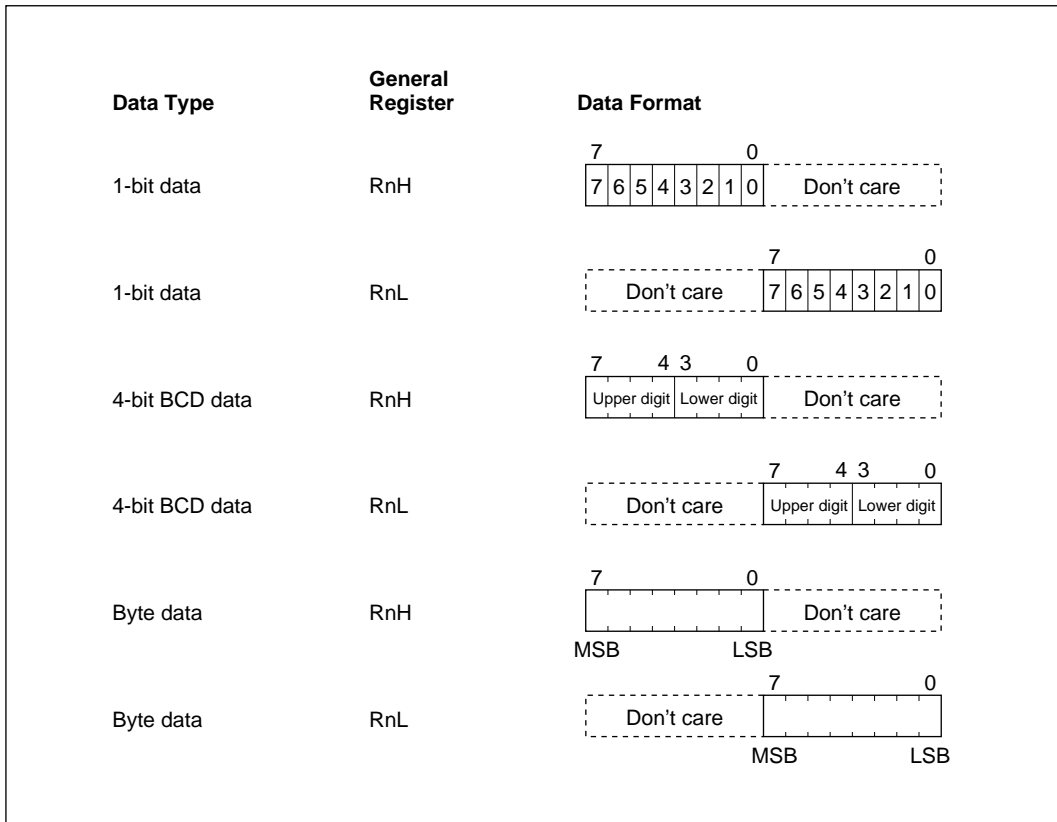

Figure 2-6 General Register Data Formats (1)

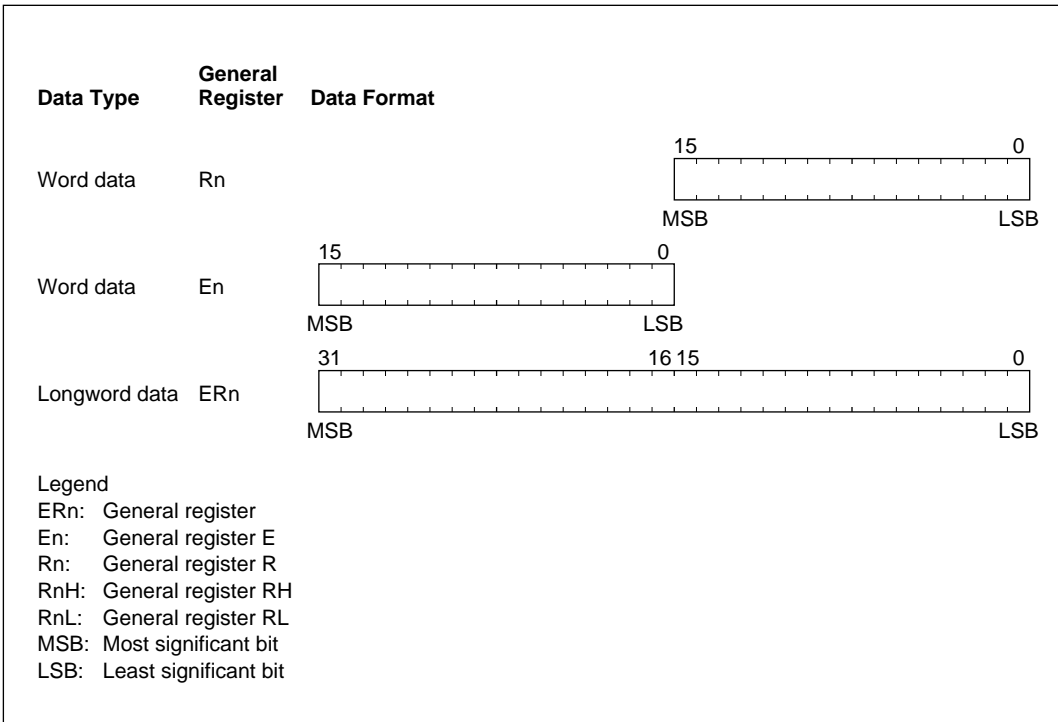

Figure 2-7 General Register Data Formats (2)

2.5.2 Memory Data Formats

Figure 2-8 shows the data formats on memory. The H8/300H CPU can access word data and longword data on memory, but word or longword data must begin at an even address. If an attempt is made to access word or longword data at an odd address, no address error occurs but the least significant bit of the address is regarded as 0, so the access starts at the preceding address. This also applies to instruction fetches.

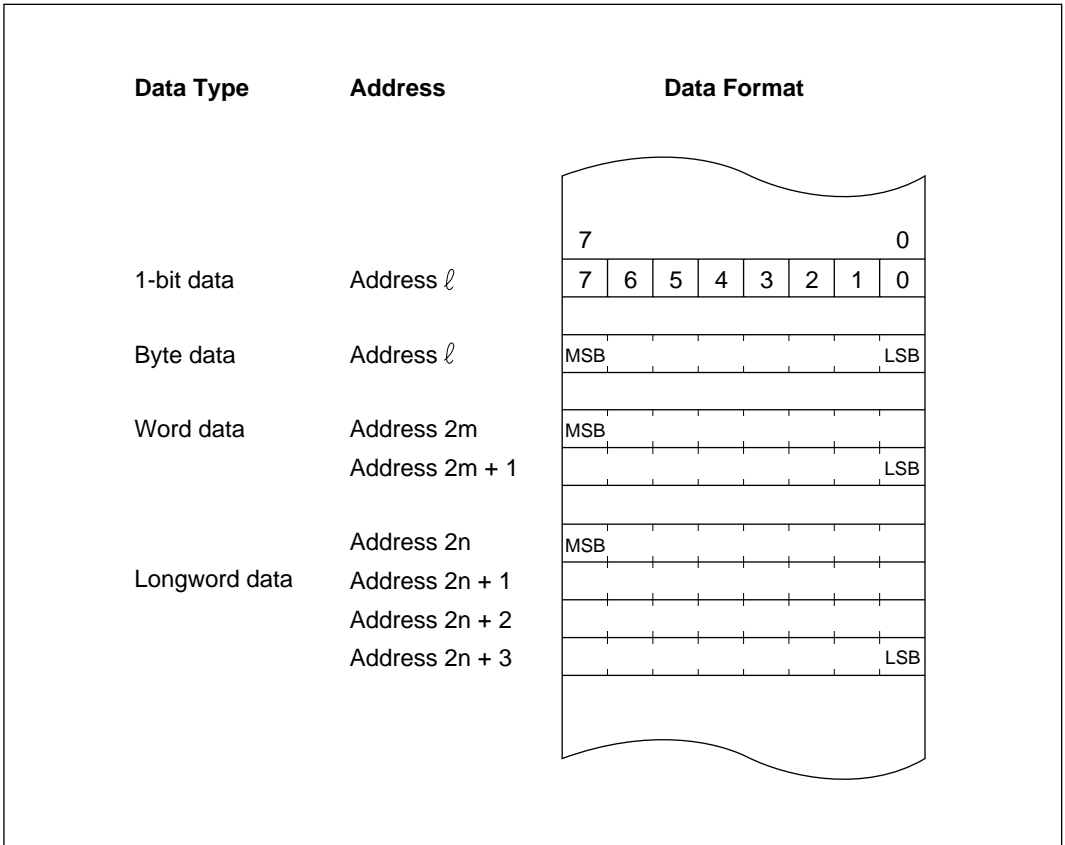

Figure 2-8 Memory Data Formats

When ER7 (SP) is used as an address register to access the stack, the operand size should be word size or longword size.

2.6 Instruction Set

2.6.1 Instruction Set Overview

The H8/300H CPU has 62 types of instructions, which are classified in table 2-1.

Table 2-1 Instruction Classification

Function	Instruction	Types
Data transfer	MOV, PUSH* ¹ , POP* ¹ , MOVTPE* ² , MOVFPE* ²	3
Arithmetic operations	ADD, SUB, ADDX, SUBX, INC, DEC, ADDS, SUBS, DAA, DAS, MULXU, DIVXU, MULXS, DIVXS, CMP, NEG, EXTS, EXTU	18
Logic operations	AND, OR, XOR, NOT	4
Shift operations	SHAL, SHAR, SHLL, SHLR, ROTL, ROTR, ROTXL, ROTXR	8
Bit manipulation	BSET, BCLR, BNOT, BTST, BAND, BAND, BOR, BIOR, BXOR, BIXOR, BLD, BILD, BST, BIST	14
Branch	Bcc* ³ , JMP, BSR, JSR, RTS	5
System control	TRAPA, RTE, SLEEP, LDC, STC, ANDC, ORC, XORC, NOP	9
Block data transfer	EEPMOV	1

Total 62 types

- Notes: 1. POP.W Rn is identical to MOV.W @SP+, Rn.
PUSH.W Rn is identical to MOV.W Rn, @-SP.
POP.L ERn is identical to MOV.L @SP+, Rn.
PUSH.L ERn is identical to MOV.L Rn, @-SP.
2. They are not available on H8/3004 and H8/3005.
3. Bcc is a generic branching instruction.

2.6.2 Instructions and Addressing Modes

Table 2-2 indicates the instructions available in the H8/300H CPU.

Table 2-2 Instructions and Addressing Modes

Function	Instruction	#xx	Rn	Addressing Modes										Implied
				@ERn	@(d:16, ERn)	@(d:24, ERn)	@ERn+/@-ERn	@aa:8	@aa:16	@aa:24	@(d:8, PC)	@(d:16, PC)	@aa:8	
Data transfer	MOV	BWL	BWL	BWL	BWL	BWL	BWL	B	BWL	BWL	—	—	—	—
	POP, PUSH	—	—	—	—	—	—	—	—	—	—	—	—	WL
	MOVFP, MOVTPE	—	—	—	—	—	—	—	B	—	—	—	—	—
Arithmetic operations	ADD, CMP	BWL	BWL	—	—	—	—	—	—	—	—	—	—	—
	SUB	WL	BWL	—	—	—	—	—	—	—	—	—	—	—
	ADDX, SUBX	B	B	—	—	—	—	—	—	—	—	—	—	—
	ADDS, SUBS	—	L	—	—	—	—	—	—	—	—	—	—	—
	INC, DEC	—	BWL	—	—	—	—	—	—	—	—	—	—	—
	DAA, DAS	—	B	—	—	—	—	—	—	—	—	—	—	—
	DIVXU, MULXS, MULXU, DIVXS	—	BW	—	—	—	—	—	—	—	—	—	—	—
	NEG	—	BWL	—	—	—	—	—	—	—	—	—	—	—
EXTU, EXTS	—	WL	—	—	—	—	—	—	—	—	—	—	—	
Logic operations	AND, OR, XOR	BWL	BWL	—	—	—	—	—	—	—	—	—	—	—
	NOT	—	BWL	—	—	—	—	—	—	—	—	—	—	—
Shift instructions	—	BWL	—	—	—	—	—	—	—	—	—	—	—	
Bit manipulation	—	B	B	—	—	—	—	B	—	—	—	—	—	
Branch	Bcc, BSR	—	—	—	—	—	—	—	—	—	○	○	—	—
	JMP, JSR	—	—	○	—	—	—	—	—	○	—	—	○	—
	RTS	—	—	—	—	—	—	—	—	—	—	—	—	○
System control	TRAPA	—	—	—	—	—	—	—	—	—	—	—	—	○
	RTE	—	—	—	—	—	—	—	—	—	—	—	—	○
	SLEEP	—	—	—	—	—	—	—	—	—	—	—	—	○
	LDC	B	B	W	W	W	W	—	W	W	—	—	—	—
	STC	—	B	W	W	W	W	—	W	W	—	—	—	—
	ANDC, ORC, XORC	B	—	—	—	—	—	—	—	—	—	—	—	—
	NOP	—	—	—	—	—	—	—	—	—	—	—	—	○
Block data transfer	—	—	—	—	—	—	—	—	—	—	—	—	—	BW

Legend

B: Byte

W: Word

L: Longword

2.6.3 Tables of Instructions Classified by Function

Tables 2-3 to 2-10 summarize the instructions in each functional category. The operation notation used in these tables is defined next.

Operation Notation

Rd	General register (destination)*
Rs	General register (source)*
Rn	General register*
ERn	General register (32-bit register or address register)
(EAd)	Destination operand
(EAs)	Source operand
CCR	Condition code register
N	N (negative) flag of CCR
Z	Z (zero) flag of CCR
V	V (overflow) flag of CCR
C	C (carry) flag of CCR
PC	Program counter
SP	Stack pointer
#IMM	Immediate data
disp	Displacement
+	Addition
-	Subtraction
×	Multiplication
÷	Division
^	AND logical
∨	OR logical
⊕	Exclusive OR logical
→	Move
¬	NOT (logical complement)
:3/:8/:16/:24	3-, 8-, 16-, or 24-bit length

Note: * General registers include 8-bit registers (R0H to R7H, R0L to R7L), 16-bit registers (R0 to R7, E0 to E7), and 32-bit data or address registers (ER0 to ER7).

Table 2-3 Data Transfer Instructions

Instruction	Size*	Function
MOV	B/W/L	(EAs) \rightarrow Rd, Rs \leftarrow (EAd) Moves data between two general registers or between a general register and memory, or moves immediate data to a general register.
MOVFPPE	B	(EAs) \rightarrow Rd Cannot be used in the H8/3004 and H8/3005.
MOVTPE	B	Rs \leftarrow (EAs) Cannot be used in the H8/3004 and H8/3005.
POP	W/L	@SP+ \rightarrow Rn Pops a general register from the stack. POP.W Rn is identical to MOV.W @SP+, Rn. Similarly, POP.L ERn is identical to MOV.L @SP+, ERn.
PUSH	W/L	Rn \rightarrow @-SP Pushes a general register onto the stack. PUSH.W Rn is identical to MOV.W Rn, @-SP. Similarly, PUSH.L ERn is identical to MOV.L ERn, @-SP.

Note: * Size refers to the operand size.

B: Byte

W: Word

L: Longword

Table 2-4 Arithmetic Operation Instructions

Instruction	Size*	Function
ADD, SUB	B/W/L	$Rd \pm Rs - Rd, Rd \pm \#IMM - Rd$ Performs addition or subtraction on data in two general registers, or on immediate data and data in a general register. (Immediate byte data cannot be subtracted from data in a general register. Use the SUBX or ADD instruction.)
ADDX, SUBX	B	$Rd \pm Rs \pm C - Rd, Rd \pm \#IMM \pm C - Rd$ Performs addition or subtraction with carry or borrow on data in two general registers, or on immediate data and data in a general register.
INC, DEC	B/W/L	$Rd \pm 1 - Rd, Rd \pm 2 - Rd$ Increments or decrements a general register by 1 or 2. (Byte operands can be incremented or decremented by 1 only.)
ADDS, SUBS	L	$Rd \pm 1 - Rd, Rd \pm 2 - Rd, Rd \pm 4 - Rd$ Adds or subtracts the value 1, 2, or 4 to or from data in a 32-bit register.
DAA, DAS	B	Rd decimal adjust $- Rd$ Decimal-adjusts an addition or subtraction result in a general register by referring to CCR to produce 4-bit BCD data.
MULXU	B/W	$Rd \times Rs - Rd$ Performs unsigned multiplication on data in two general registers: either 8 bits \times 8 bits \rightarrow 16 bits or 16 bits \times 16 bits \rightarrow 32 bits.
MULXS	B/W	$Rd \times Rs - Rd$ Performs signed multiplication on data in two general registers: either 8 bits \times 8 bits \rightarrow 16 bits or 16 bits \times 16 bits \rightarrow 32 bits.

Note: * Size refers to the operand size.

B: Byte

W: Word

L: Longword

Table 2-4 Arithmetic Operation Instructions (cont)

Instruction	Size*	Function
DIVXU	B/W	$Rd \div Rs \rightarrow Rd$ Performs unsigned division on data in two general registers: either 16 bits \div 8 bits \rightarrow 8-bit quotient and 8-bit remainder or 32 bits \div 16 bits \rightarrow 16-bit quotient and 16-bit remainder.
DIVXS	B/W	$Rd \div Rs \rightarrow Rd$ Performs signed division on data in two general registers: either 16 bits \div 8 bits \rightarrow 8-bit quotient and 8-bit remainder, or 32 bits \div 16 bits \rightarrow 16-bit quotient and 16-bit remainder.
CMP	B/W/L	$Rd - Rs, Rd - \#IMM$ Compares data in a general register with data in another general register or with immediate data, and sets CCR according to the result.
NEG	B/W/L	$0 - Rd \rightarrow Rd$ Takes the two's complement (arithmetic complement) of data in a general register.
EXTS	W/L	Rd (sign extension) $\rightarrow Rd$ Extends byte data in the lower 8 bits of a 16-bit register to word data, or extends word data in the lower 16 bits of a 32-bit register to longword data, by extending the sign bit.
EXTU	W/L	Rd (zero extension) $\rightarrow Rd$ Extends byte data in the lower 8 bits of a 16-bit register to word data, or extends word data in the lower 16 bits of a 32-bit register to longword data, by padding with zeros.

Note: * Size refers to the operand size.

B: Byte

W: Word

L: Longword

Table 2-5 Logic Operation Instructions

Instruction	Size*	Function
AND	B/W/L	$Rd \wedge Rs \rightarrow Rd$, $Rd \wedge \#IMM \rightarrow Rd$ Performs a logical AND operation on a general register and another general register or immediate data.
OR	B/W/L	$Rd \vee Rs \rightarrow Rd$, $Rd \vee \#IMM \rightarrow Rd$ Performs a logical OR operation on a general register and another general register or immediate data.
XOR	B/W/L	$Rd \oplus Rs \rightarrow Rd$, $Rd \oplus \#IMM \rightarrow Rd$ Performs a logical exclusive OR operation on a general register and another general register or immediate data.
NOT	B/W/L	$\neg Rd \rightarrow Rd$ Takes the one's complement of general register contents.

Note: * Size refers to the operand size.

B: Byte

W: Word

L: Longword

Table 2-6 Shift Instructions

Instruction	Size*	Function
SHAL, SHAR	B/W/L	Rd (shift) $\rightarrow Rd$ Performs an arithmetic shift on general register contents.
SHLL, SHLR	B/W/L	Rd (shift) $\rightarrow Rd$ Performs a logical shift on general register contents.
ROTL, ROTR	B/W/L	Rd (rotate) $\rightarrow Rd$ Rotates general register contents.
ROTXL, ROTXR	B/W/L	Rd (rotate) $\rightarrow Rd$ Rotates general register contents through the carry bit.

Note: * Size refers to the operand size.

B: Byte

W: Word

L: Longword

Table 2-7 Bit Manipulation Instructions

Instruction	Size*	Function
BSET	B	1 \neg (bit-No.) of <EAd> Sets a specified bit in a general register or memory operand to 1. The bit number is specified by 3-bit immediate data or the lower 3 bits of a general register.
BCLR	B	0 (bit-No.) of <EAd> Clears a specified bit in a general register or memory operand to 0. The bit number is specified by 3-bit immediate data or the lower 3 bits of a general register.
BNOT	B	\neg (bit-No.) of <EAd> \neg (bit-No.) of <EAd> Inverts a specified bit in a general register or memory operand. The bit number is specified by 3-bit immediate data or the lower 3 bits of a general register.
BTST	B	\neg (bit-No.) of <EAd> \neg Z Tests a specified bit in a general register or memory operand and sets or clears the Z flag accordingly. The bit number is specified by 3-bit immediate data or the lower 3 bits of a general register.
BAND	B	C \wedge (bit-No.) of <EAd> \neg C ANDs the carry flag with a specified bit in a general register or memory operand and stores the result in the carry flag.
BIAND	B	C \wedge [\neg (bit-No.) of <EAd>] \neg C ANDs the carry flag with the inverse of a specified bit in a general register or memory operand and stores the result in the carry flag. The bit number is specified by 3-bit immediate data.

Note: * Size refers to the operand size.

B: Byte

Table 2-7 Bit Manipulation Instructions (cont)

Instruction	Size*	Function
BOR	B	$C \vee \langle \text{bit-No.} \rangle \text{ of } \langle \text{EAd} \rangle - \mathcal{C}$ ORs the carry flag with a specified bit in a general register or memory operand and stores the result in the carry flag.
BIOR	B	$C \vee [\neg \langle \text{bit-No.} \rangle \text{ of } \langle \text{EAd} \rangle] - \mathcal{C}$ ORs the carry flag with the inverse of a specified bit in a general register or memory operand and stores the result in the carry flag. The bit number is specified by 3-bit immediate data.
BXOR	B	$C \oplus \langle \text{bit-No.} \rangle \text{ of } \langle \text{EAd} \rangle - \mathcal{C}$ Exclusive-ORs the carry flag with a specified bit in a general register or memory operand and stores the result in the carry flag.
BIXOR	B	$C \oplus [\neg \langle \text{bit-No.} \rangle \text{ of } \langle \text{EAd} \rangle] - \mathcal{C}$ Exclusive-ORs the carry flag with the inverse of a specified bit in a general register or memory operand and stores the result in the carry flag. The bit number is specified by 3-bit immediate data.
BLD	B	$\langle \text{bit-No.} \rangle \text{ of } \langle \text{EAd} \rangle - \mathcal{C}$ Transfers a specified bit in a general register or memory operand to the carry flag.
BILD	B	$\neg \langle \text{bit-No.} \rangle \text{ of } \langle \text{EAd} \rangle - \mathcal{C}$ Transfers the inverse of a specified bit in a general register or memory operand to the carry flag. The bit number is specified by 3-bit immediate data.
BST	B	$C \rightarrow \langle \text{bit-No.} \rangle \text{ of } \langle \text{EAd} \rangle$ Transfers the carry flag value to a specified bit in a general register or memory operand.
BIST	B	$C \rightarrow \neg \langle \text{bit-No.} \rangle \text{ of } \langle \text{EAd} \rangle$ Transfers the inverse of the carry flag value to a specified bit in a general register or memory operand. The bit number is specified by 3-bit immediate data.

Note: * Size refers to the operand size.

B: Byte

Table 2-8 Branching Instructions

Instruction	Size	Function																																																			
Bcc	—	Branches to a specified address if a specified condition is true. The branching conditions are listed below.																																																			
		<table border="1"> <thead> <tr> <th>Mnemonic</th> <th>Description</th> <th>Condition</th> </tr> </thead> <tbody> <tr> <td>BRA (BT)</td> <td>Always (true)</td> <td>Always</td> </tr> <tr> <td>BRN (BF)</td> <td>Never (false)</td> <td>Never</td> </tr> <tr> <td>BHI</td> <td>High</td> <td>$C \vee Z = 0$</td> </tr> <tr> <td>BLS</td> <td>Low or same</td> <td>$C \vee Z = 1$</td> </tr> <tr> <td>Bcc (BHS)</td> <td>Carry clear (high or same)</td> <td>$C = 0$</td> </tr> <tr> <td>BCS (BLO)</td> <td>Carry set (low)</td> <td>$C = 1$</td> </tr> <tr> <td>BNE</td> <td>Not equal</td> <td>$Z = 0$</td> </tr> <tr> <td>BEQ</td> <td>Equal</td> <td>$Z = 1$</td> </tr> <tr> <td>BVC</td> <td>Overflow clear</td> <td>$V = 0$</td> </tr> <tr> <td>BVS</td> <td>Overflow set</td> <td>$V = 1$</td> </tr> <tr> <td>BPL</td> <td>Plus</td> <td>$N = 0$</td> </tr> <tr> <td>BMI</td> <td>Minus</td> <td>$N = 1$</td> </tr> <tr> <td>BGE</td> <td>Greater or equal</td> <td>$N \oplus V = 0$</td> </tr> <tr> <td>BLT</td> <td>Less than</td> <td>$N \oplus V = 1$</td> </tr> <tr> <td>BGT</td> <td>Greater than</td> <td>$Z \vee (N \oplus V) = 0$</td> </tr> <tr> <td>BLE</td> <td>Less or equal</td> <td>$Z \vee (N \oplus V) = 1$</td> </tr> </tbody> </table>	Mnemonic	Description	Condition	BRA (BT)	Always (true)	Always	BRN (BF)	Never (false)	Never	BHI	High	$C \vee Z = 0$	BLS	Low or same	$C \vee Z = 1$	Bcc (BHS)	Carry clear (high or same)	$C = 0$	BCS (BLO)	Carry set (low)	$C = 1$	BNE	Not equal	$Z = 0$	BEQ	Equal	$Z = 1$	BVC	Overflow clear	$V = 0$	BVS	Overflow set	$V = 1$	BPL	Plus	$N = 0$	BMI	Minus	$N = 1$	BGE	Greater or equal	$N \oplus V = 0$	BLT	Less than	$N \oplus V = 1$	BGT	Greater than	$Z \vee (N \oplus V) = 0$	BLE	Less or equal	$Z \vee (N \oplus V) = 1$
Mnemonic	Description	Condition																																																			
BRA (BT)	Always (true)	Always																																																			
BRN (BF)	Never (false)	Never																																																			
BHI	High	$C \vee Z = 0$																																																			
BLS	Low or same	$C \vee Z = 1$																																																			
Bcc (BHS)	Carry clear (high or same)	$C = 0$																																																			
BCS (BLO)	Carry set (low)	$C = 1$																																																			
BNE	Not equal	$Z = 0$																																																			
BEQ	Equal	$Z = 1$																																																			
BVC	Overflow clear	$V = 0$																																																			
BVS	Overflow set	$V = 1$																																																			
BPL	Plus	$N = 0$																																																			
BMI	Minus	$N = 1$																																																			
BGE	Greater or equal	$N \oplus V = 0$																																																			
BLT	Less than	$N \oplus V = 1$																																																			
BGT	Greater than	$Z \vee (N \oplus V) = 0$																																																			
BLE	Less or equal	$Z \vee (N \oplus V) = 1$																																																			
JMP	—	Branches unconditionally to a specified address																																																			
BSR	—	Branches to a subroutine at a specified address																																																			
JSR	—	Branches to a subroutine at a specified address																																																			
RTS	—	Returns from a subroutine																																																			

Table 2-9 System Control Instructions

Instruction	Size*	Function
TRAPA	—	Starts trap-instruction exception handling
RTE	—	Returns from an exception-handling routine
SLEEP	—	Causes a transition to the power-down state
LDC	B/W	(EAs) ←CCR Moves the source operand contents to the condition code register. The condition code register size is one byte, but in transfer from memory, data is read by word access.
STC	B/W	CCR →(EAd) Transfers the CCR contents to a destination location. The condition code register size is one byte, but in transfer to memory, data is written by word access.
ANDC	B	CCR ∧#IMM ←CCR Logically ANDs the condition code register with immediate data.
ORC	B	CCR ∨#IMM ←CCR Logically ORs the condition code register with immediate data.
XORC	B	CCR ⊕#IMM ←CCR Logically exclusive-ORs the condition code register with immediate data.
NOP	—	PC + 2 →PC Only increments the program counter.

Note: * Size refers to the operand size.

B: Byte

W: Word

Table 2-10 Block Transfer Instruction

Instruction	Size	Function
EEPMOV.B	—	<p>if R4L ≠ 0 then</p> <p> repeat @ER5+ –@ER6+, R4L – 1 –R4L</p> <p> until R4L = 0</p> <p>else next;</p>
EEPMOV.W	—	<p>if R4 ≠ 0 then</p> <p> repeat @ER5+ –@ER6+, R4 – 1 –R4</p> <p> until R4 = 0</p> <p>else next;</p> <p>Transfers a data block according to parameters set in general registers R4L or R4, ER5, and ER6.</p> <p>R4L or R4: Size of block (bytes)</p> <p>ER5: Starting source address</p> <p>ER6: Starting destination address</p> <p>Execution of the next instruction begins as soon as the transfer is completed.</p>

2.6.4 Basic Instruction Formats

The H8/300H instructions consist of 2-byte (1-word) units. An instruction consists of an operation field (OP field), a register field (r field), an effective address extension (EA field), and a condition field (cc).

Operation Field: Indicates the function of the instruction, the addressing mode, and the operation to be carried out on the operand. The operation field always includes the first 4 bits of the instruction. Some instructions have two operation fields.

Register Field: Specifies a general register. Address registers are specified by 3 bits, data registers by 3 bits or 4 bits. Some instructions have two register fields. Some have no register field.

Effective Address Extension: Eight, 16, or 32 bits specifying immediate data, an absolute address, or a displacement. A 24-bit address or displacement is treated as 32-bit data in which the first 8 bits are 0 (H'00).

Condition Field: Specifies the branching condition of Bcc instructions.

Figure 2-9 shows examples of instruction formats.

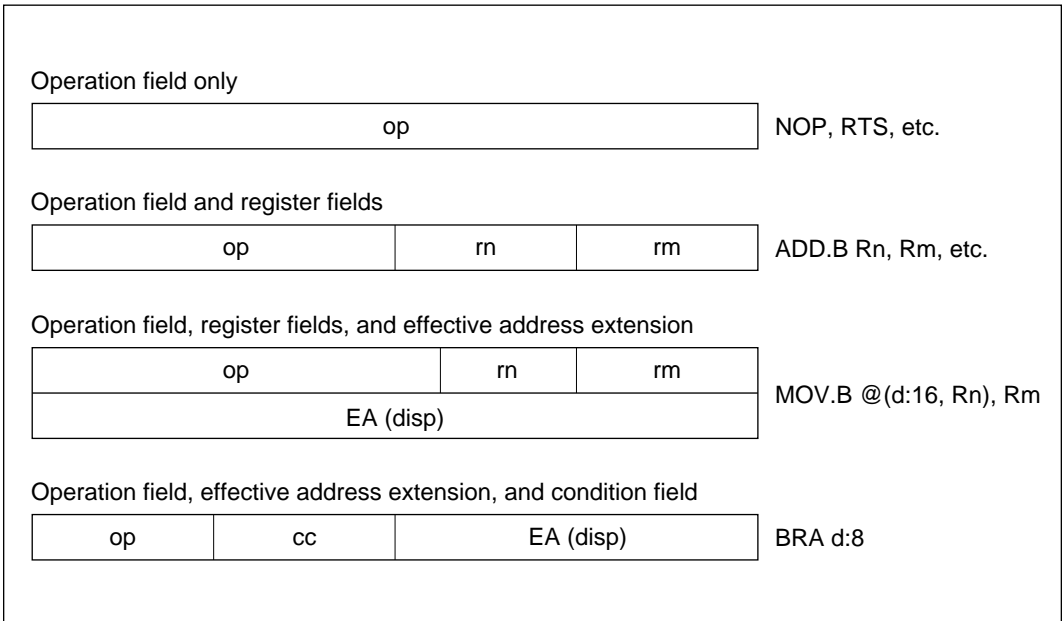

Figure 2-9 Instruction Formats

2.6.5 Notes on Use of Bit Manipulation Instructions

The BSET, BCLR, BNOT, BST, and BIST instructions read a byte of data, modify a bit in the byte, then write the byte back. Care is required when these instructions are used to access registers with write-only bits, or to access ports.

The BCLR instruction can be used to clear flags in the on-chip registers. In an interrupt-handling routine, for example, if it is known that the flag is set to 1, it is not necessary to read the flag ahead of time.

2.7 Addressing Modes and Effective Address Calculation

2.7.1 Addressing Modes

The H8/300H CPU supports the eight addressing modes listed in table 2-11. Each instruction uses a subset of these addressing modes. Arithmetic and logic instructions can use the register direct and immediate modes. Data transfer instructions can use all addressing modes except program-counter relative and memory indirect. Bit manipulation instructions use register direct, register indirect, or absolute (@aa:8) addressing mode to specify an operand, and register direct (BSET, BCLR, BNOT, and BTST instructions) or immediate (3-bit) addressing mode to specify a bit number in the operand.

Table 2-11 Addressing Modes

No.	Addressing Mode	Symbol
1	Register direct	Rn
2	Register indirect	@ERn
3	Register indirect with displacement	@(d:16, ERn)/@d:24, ERn)
4	Register indirect with post-increment Register indirect with pre-decrement	@ERn+ @-ERn
5	Absolute address	@aa:8/@aa:16/@aa:24
6	Immediate	#xx:8/#xx:16/#xx:32
7	Program-counter relative	@(d:8, PC)/@(d:16, PC)
8	Memory indirect	@@aa:8

1 Register Direct—Rn: The register field of the instruction code specifies an 8-, 16-, or 32-bit register containing the operand. R0H to R7H and R0L to R7L can be specified as 8-bit registers. R0 to R7 and E0 to E7 can be specified as 16-bit registers. ER0 to ER7 can be specified as 32-bit registers.

2 Register Indirect—@ERn: The register field of the instruction code specifies an address register (ERn), the lower 24 bits of which contain the address of the operand.

3 Register Indirect with Displacement—@(d:16, ERn) or @(d:24, ERn): A 16-bit or 24-bit displacement contained in the instruction code is added to the contents of an address register (ERn) specified by the register field of the instruction, and the lower 24 bits of the sum specify the address of a memory operand. A 16-bit displacement is sign-extended when added.

4 Register Indirect with Post-Increment or Pre-Decrement—@ERn+ or @-ERn:

- Register indirect with post-increment—@ERn+

The register field of the instruction code specifies an address register (ERn) the lower 24 bits of which contain the address of a memory operand. After the operand is accessed, 1, 2, or 4 is added to the address register contents (32 bits) and the sum is stored in the address register. The value added is 1 for byte access, 2 for word access, or 4 for longword access. For word or longword access, the register value should be even.

- Register indirect with pre-decrement—@-ERn

The value 1, 2, or 4 is subtracted from an address register (ERn) specified by the register field in the instruction code, and the lower 24 bits of the result become the address of a memory operand. The result is also stored in the address register. The value subtracted is 1 for byte access, 2 for word access, or 4 for longword access. For word or longword access, the resulting register value should be even.

5 Absolute Address—@aa:8, @aa:16, or @aa:24: The instruction code contains the absolute address of a memory operand. The absolute address may be 8 bits long (@aa:8), 16 bits long (@aa:16), or 24 bits long (@aa:24). For an 8-bit absolute address, the upper 16 bits are all assumed to be 1 (H'FFFF). For a 16-bit absolute address the upper 8 bits are a sign extension. A 24-bit absolute address can access the entire address space. Table 2-12 indicates the accessible address ranges.

Table 2-12 Absolute Address Access Ranges

Absolute Address	1-Mbyte Modes	16-Mbyte Modes
8 bits (@aa:8)	H'FFF00 to H'FFFFF (1048320 to 1048575)	H'FFFF00 to H'FFFFFF (16776960 to 16777215)
16 bits (@aa:16)	H'00000 to H'07FFF, H'F8000 to H'FFFFFF (0 to 32767, 1015808 to 1048575)	H'000000 to H'007FFF, H'FF8000 to H'FFFFFF (0 to 32767, 16744448 to 16777215)
24 bits (@aa:24)	H'00000 to H'FFFFFF (0 to 1048575)	H'000000 to H'FFFFFF (0 to 16777215)

6 Immediate—#xx:8, #xx:16, or #xx:32: The instruction code contains 8-bit (#xx:8), 16-bit (#xx:16), or 32-bit (#xx:32) immediate data as an operand.

The instruction codes of the ADDS, SUBS, INC, and DEC instructions contain immediate data implicitly. The instruction codes of some bit manipulation instructions contain 3-bit immediate data specifying a bit number. The TRAPA instruction code contains 2-bit immediate data specifying a vector address.

7 Program-Counter Relative—@(d:8, PC) or @(d:16, PC): This mode is used in the Bcc and BSR instructions. An 8-bit or 16-bit displacement contained in the instruction code is sign-extended to 24 bits and added to the 24-bit PC contents to generate a 24-bit branch address. The PC value to which the displacement is added is the address of the first byte of the next instruction, so the possible branching range is -126 to $+128$ bytes (-63 to $+64$ words) or -32766 to $+32768$ bytes (-16383 to $+16384$ words) from the branch instruction. The resulting value should be an even number.

8 Memory Indirect—@@aa:8: This mode can be used by the JMP and JSR instructions. The instruction code contains an 8-bit absolute address specifying a memory operand. This memory operand contains a branch address. The memory operand is accessed by longword access. The first byte of the memory operand is ignored, generating a 24-bit branch address. See figure 2-10. The upper bits of the 8-bit absolute address are assumed to be 0 (H'0000), so the address range is 0 to 255 (H'000000 to H'0000FF). Note that the first part of this range is also the exception vector area. For further details see section 5, Interrupt Controller.

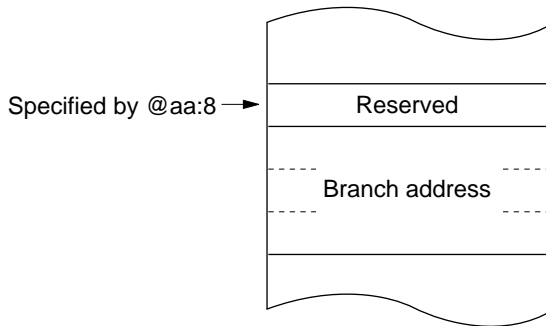

Figure 2-10 Memory-Indirect Branch Address Specification

When a word-size or longword-size memory operand is specified, or when a branch address is specified, if the specified memory address is odd, the least significant bit is regarded as 0. The accessed data or instruction code therefore begins at the preceding address. See section 2.5.2, Memory Data Formats.

2.7.2 Effective Address Calculation

Table 2-13 explains how an effective address is calculated in each addressing mode. In the 1-Mbyte operating modes the upper 4 bits of the calculated address are ignored in order to generate a 20-bit effective address.

Table 2-13 Effective Address Calculation

No.	Addressing Mode and Instruction Format	Effective Address Calculation	Effective Address
1	Register direct (Rn) op rm rn		Operand is general register contents
2	Register indirect (@ERn) op r		
3	Register indirect with displacement @(d:16, ERn)/@(d:24, ERn) op r disp		
4	Register indirect with post-increment or pre-decrement		
	Register indirect with post-increment @ERn+ op r		
	Register indirect with pre-decrement @-ERn op r		

1 for a byte operand, 2 for a word operand, 4 for a longword operand

Table 2-13 Effective Address Calculation (cont)







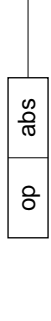

No.	Addressing Mode and Instruction Format	Effective Address Calculation	Effective Address
5	Absolute address @aa:8		
	@aa:16		
	@aa:24		
6	Immediate #xx:8, #xx:16, or #xx:32		Operand is immediate data
7	Program-counter relative @(d:8, PC) or @(d:16, PC)		

Table 2-13 Effective Address Calculation (cont)

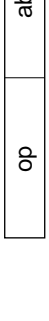

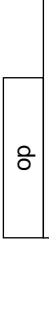
Legend

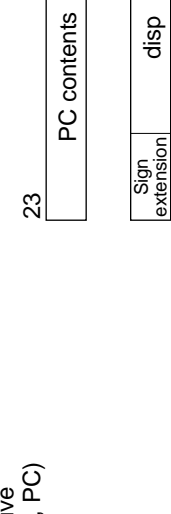
- r, rm, rn: Register field
- op: Operation field
- disp: Displacement
- IMM: Immediate data
- abs: Absolute address

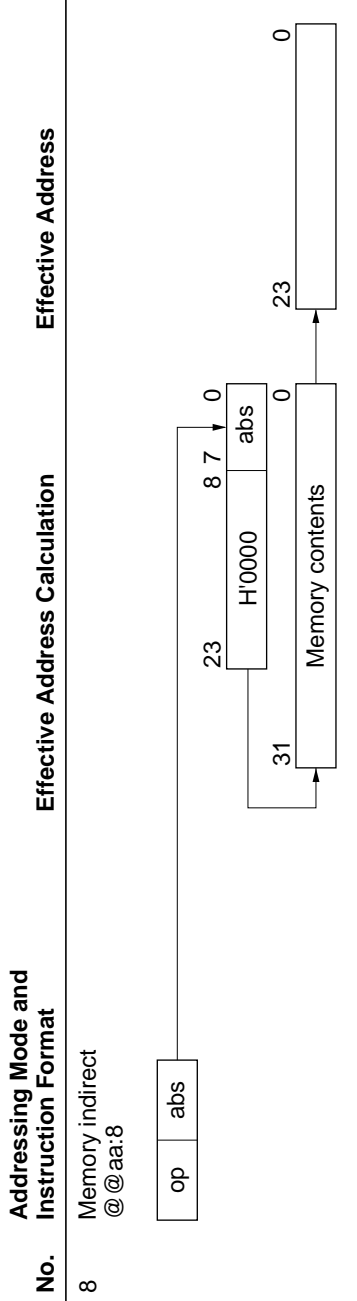
2.8 Processing States

2.8.1 Overview

The H8/300H CPU has five processing states: the program execution state, exception-handling state, power-down state, reset state, and bus-released state. The power-down state includes sleep mode, software standby mode, and hardware standby mode. Figure 2-11 classifies the processing states. Figure 2-13 indicates the state transitions.

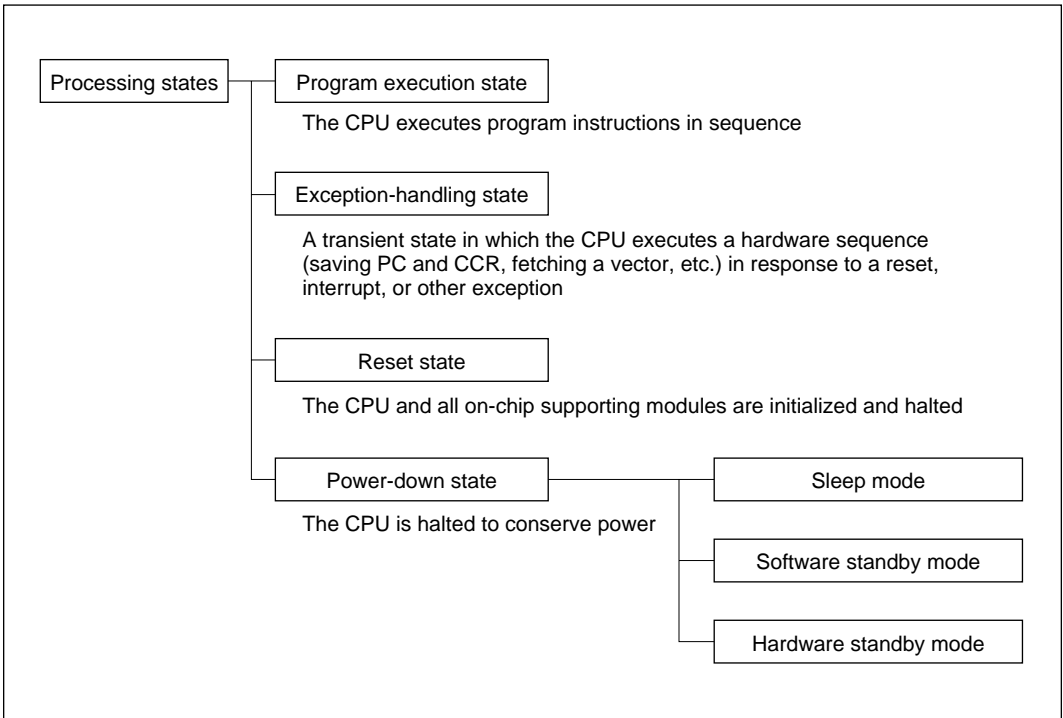

Figure 2-11 Processing States

2.8.2 Program Execution State

In this state the CPU executes program instructions in normal sequence.

2.8.3 Exception-Handling State

The exception-handling state is a transient state that occurs when the CPU alters the normal program flow due to a reset, interrupt, or trap instruction. The CPU fetches a starting address from the exception vector table and branches to that address. In interrupt and trap exception handling the CPU references the stack pointer (ER7) and saves the program counter and condition code register.

Types of Exception Handling and Their Priority: Exception handling is performed for resets, interrupts, and trap instructions. Table 2-14 indicates the types of exception handling and their priority. Trap instruction exceptions are accepted at all times in the program execution state.

Table 2-14 Exception Handling Types and Priority

Priority	Type of Exception	Detection Timing	Start of Exception Handling
High	Reset	Synchronized with clock	Exception handling starts immediately when RES changes from low to high
↑	Interrupt	End of instruction execution or end of exception handling*	When an interrupt is requested, exception handling starts at the end of the current instruction or current exception-handling sequence
	Trap instruction	When TRAPA instruction is executed	Exception handling starts when a trap (TRAPA) instruction is executed
Low			

Note: * Interrupts are not detected at the end of the ANDC, ORC, XORC, and LDC instructions, or immediately after reset exception handling.

Figure 2-12 classifies the exception sources. For further details about exception sources, vector numbers, and vector addresses, see section 4, Exception Handling, and section 5, Interrupt Controller.

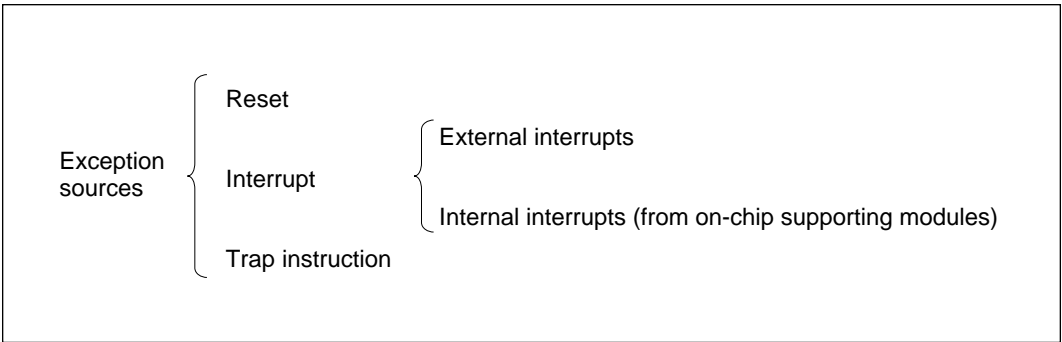

Figure 2-12 Classification of Exception Sources

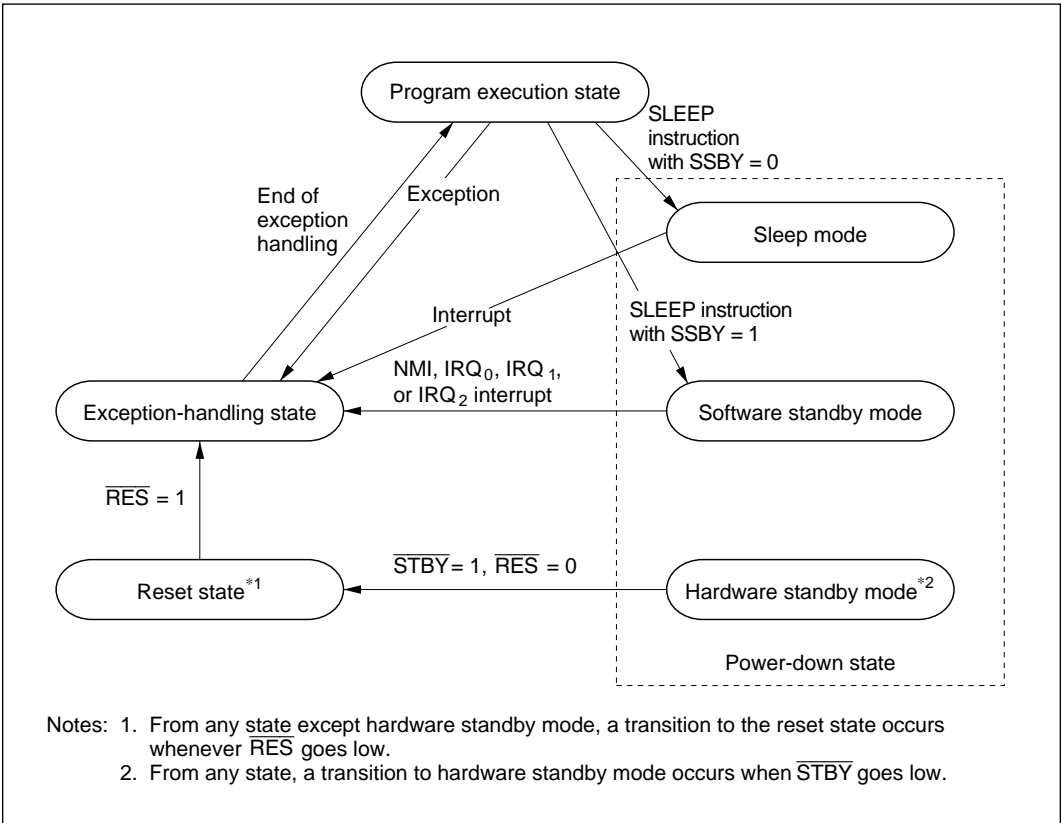

Figure 2-13 State Transitions

2.8.4 Exception-Handling Sequences

Reset Exception Handling: Reset exception handling has the highest priority. The reset state is entered when the \overline{RES} signal goes low. Reset exception handling starts after that, when \overline{RES} changes from low to high. When reset exception handling starts the CPU fetches a start address from the exception vector table and starts program execution from that address. All interrupts, including NMI, are disabled during the reset exception-handling sequence and immediately after it ends.

Interrupt Exception Handling and Trap Instruction Exception Handling: When these exception-handling sequences begin, the CPU references the stack pointer (ER7) and pushes the program counter and condition code register on the stack. Next, if the UE bit in the system control register (SYSCR) is set to 1, the CPU sets the I bit in the condition code register to 1. If the UE bit is cleared to 0, the CPU sets both the I bit and the UI bit in the condition code register to 1. Then the CPU fetches a start address from the exception vector table and execution branches to that address.

Figure 2-14 shows the stack after the exception-handling sequence.

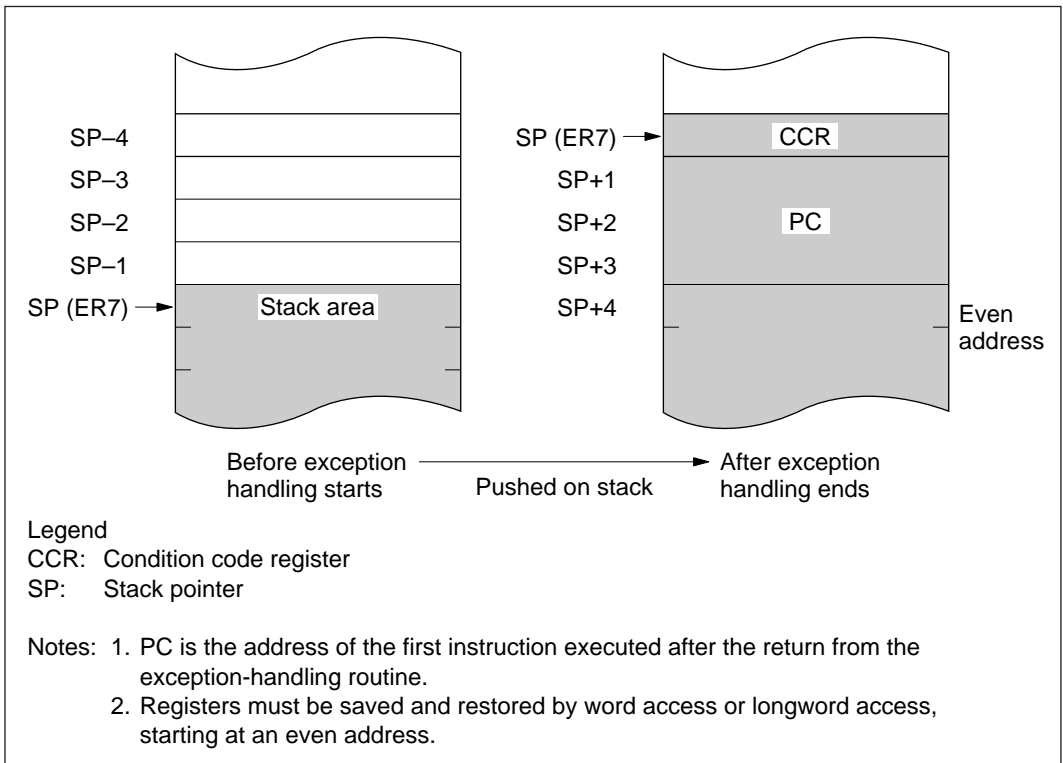

Figure 2-14 Stack Structure after Exception Handling

2.8.5 Reset State

When the $\overline{\text{RES}}$ input goes low all current processing stops and the CPU enters the reset state. The I bit in the condition code register is set to 1 by a reset. All interrupts are masked in the reset state. Reset exception handling starts when the $\overline{\text{RES}}$ signal changes from low to high.

The reset state can also be entered by a watchdog timer overflow. For details see section 10, Watchdog Timer.

2.8.6 Power-Down State

In the power-down state the CPU stops operating to conserve power. There are three modes: sleep mode, software standby mode, and hardware standby mode.

Sleep Mode: A transition to sleep mode is made if the SLEEP instruction is executed while the SSBY bit is cleared to 0 in the system control register (SYSCR). CPU operations stop immediately after execution of the SLEEP instruction, but the contents of CPU registers are retained.

Software Standby Mode: A transition to software standby mode is made if the SLEEP instruction is executed while the SSBY bit is set to 1 in SYSCR. The CPU and clock halt and all on-chip supporting modules stop operating. The on-chip supporting modules are reset, but as long as a specified voltage is supplied the contents of CPU registers and on-chip RAM are retained. The I/O ports also remain in their existing states.

Hardware Standby Mode: A transition to hardware standby mode is made when the $\overline{\text{STBY}}$ input goes low. As in software standby mode, the CPU and clock halt and the on-chip supporting modules are reset, but as long as a specified voltage is supplied, on-chip RAM contents are retained.

For further information see section 14, Power-Down State.

2.9 Basic Operational Timing

2.9.1 Overview

The H8/300H CPU operates according to the system clock (ϕ). The interval from one rise of the system clock to the next rise is referred to as a “state.” A memory cycle or bus cycle consists of two or three states. The CPU uses different methods to access on-chip memory, the on-chip supporting modules, and the external address space. Access to the external address space can be controlled by the bus controller.

2.9.2 On-Chip Memory Access Timing

On-chip memory is accessed in two states. The data bus is 16 bits wide, permitting both byte and word access. Figure 2-15 shows the on-chip memory access cycle. Figure 2-16 indicates the pin states.

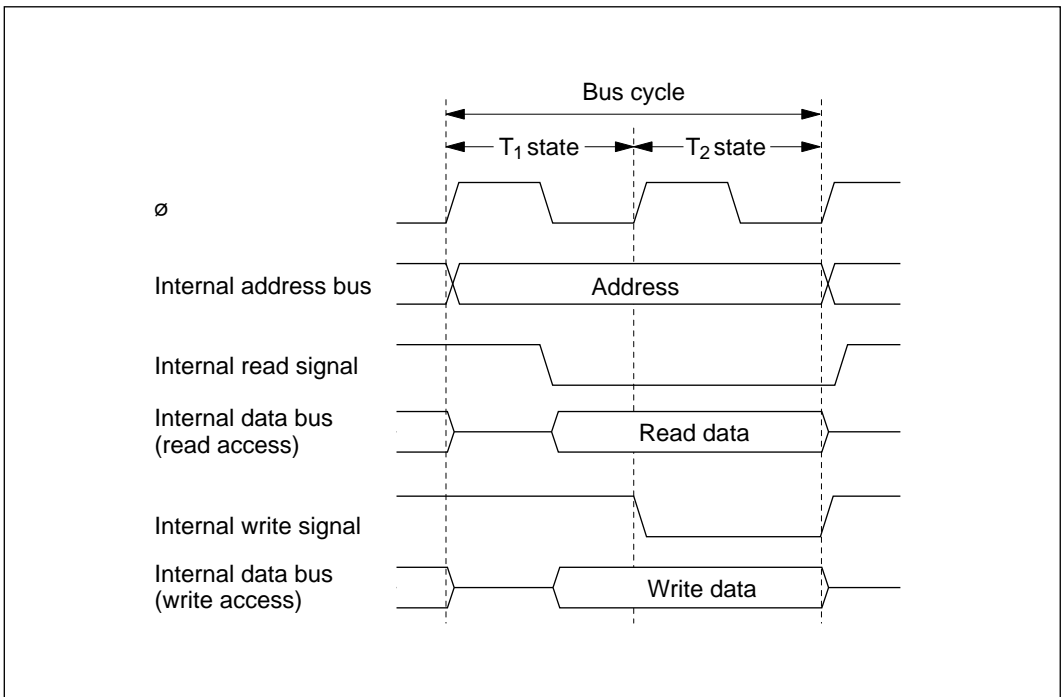

Figure 2-15 On-Chip Memory Access Cycle

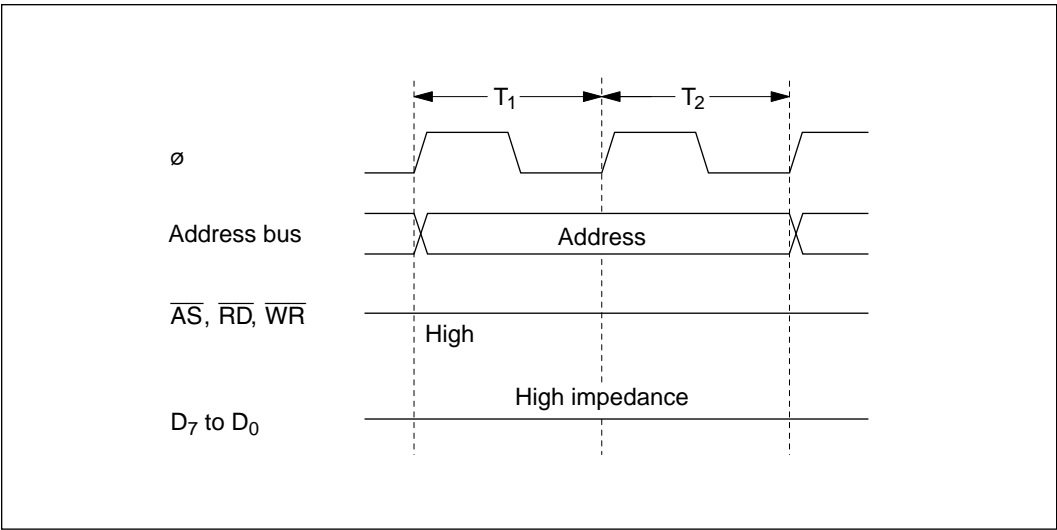

Figure 2-16 Pin States during On-Chip Memory Access

2.9.3 On-Chip Supporting Module Access Timing

The on-chip supporting modules are accessed in three states. The data bus is 8 or 16 bits wide, depending on the register being accessed. Figure 2-17 shows the on-chip supporting module access timing. Figure 2-18 indicates the pin states.

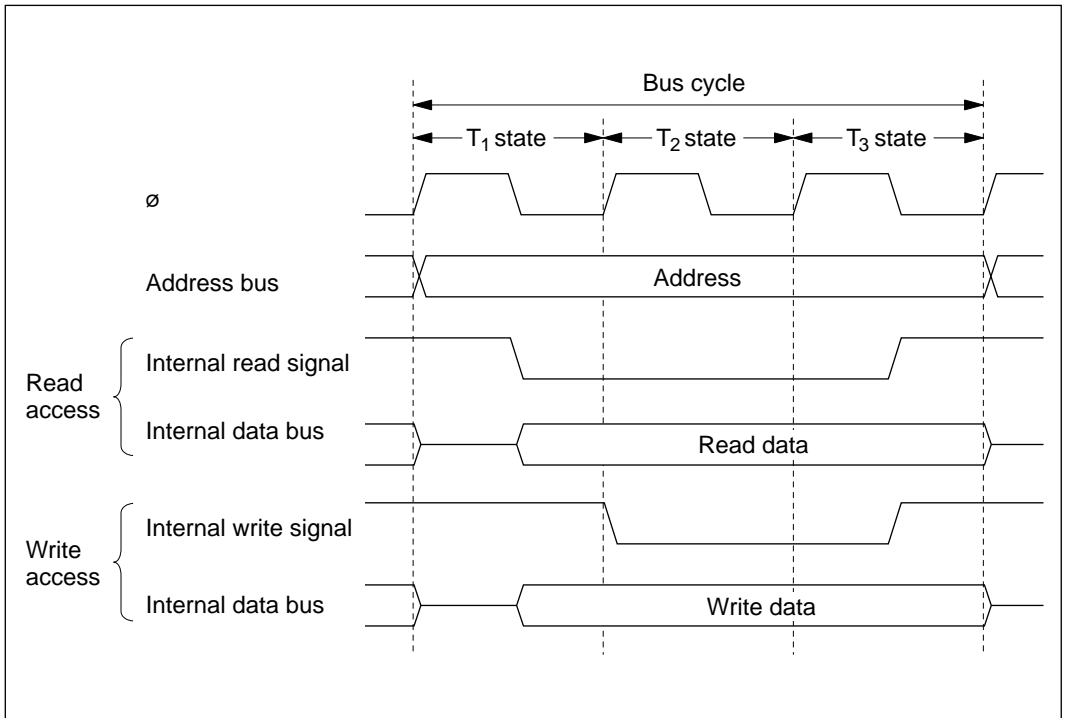

Figure 2-17 Access Cycle for On-Chip Supporting Modules

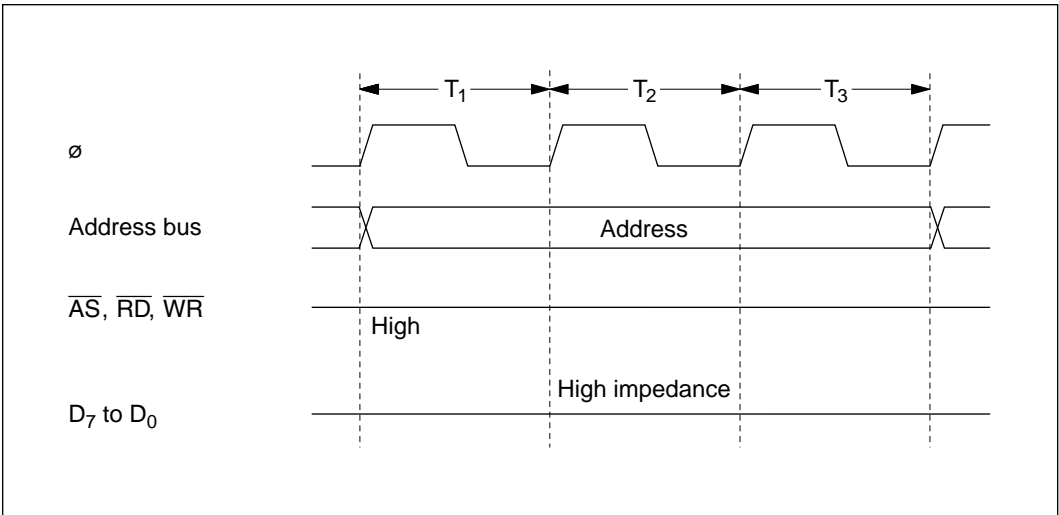

Figure 2-18 Pin States during Access to On-Chip Supporting Modules

2.9.4 Access to External Address Space

The external address space is divided into eight areas (areas 0 to 7). Bus-controller settings determine whether each area is accessed via an 8-bit or 16-bit bus, and whether it is accessed in two or three states. For details see section 6, Bus Controller.

Section 3 MCU Operating Modes

3.1 Overview

3.1.1 Operating Mode Selection

The H8/3004 and H8/3005 have two operating modes (modes 1 and 3) that are selected by the mode pins (MD_1 and MD_0) as indicated in table 3-1.

Table 3-1 Operating Mode Selection

Operating Mode	Mode Pins		Description	
	MD_1	MD_0	Address Space	On-Chip RAM
—	0	0	—	—
Mode 1	0	1	1 Mbyte	Enabled*
—	1	0	—	—
Mode 3	1	1	16 Mbyte	Enabled*

Note: * If the RAM enable bit (RAME) in the system control register (SYSCR) is cleared to 0, these addresses become external addresses.

For the address space size there are two choices: 1 Mbyte or 16 Mbyte.

Modes 1 and 3 are external expansion modes that enable an external memory peripheral device to be accessed.

Modes 1 support a maximum address space of 1 Mbyte. Mode 3 supports a maximum address space of 16 Mbytes.

The H8/3004 and H8/3005 can only be used in modes 1 and 3. The inputs at the mode pins must select modes 1 and 3. The inputs at the mode pins must not be changed during operation.

3.1.2 Register Configuration

The H8/3004 and H8/3005 have a mode control register (MDCR) that indicates the inputs at the mode pins (MD₂ to MD₀), and a system control register (SYSCR). Table 3-2 summarizes these registers.

Table 3-2 Registers

Address*	Name	Abbreviation	R/W	Initial Value
H'FFF1	Mode control register	MDCR	R	Undetermined
H'FFF2	System control register	SYSCR	R/W	H'0B

Note: * The lower 16 bits of the address are indicated.

3.2 Mode Control Register (MDCR)

MDCR is an 8-bit read-only register that indicates the current operating mode of the H8/3004 and H8/3005.

Bit	7	6	5	4	3	2	1	0
	—	—	—	—	—	—	MDS1	MDS0
Initial value	1	1	0	0	0	0	—*	—*
Read/Write	—	—	—	—	—	—	R	R

Reserved bits
Mode select 1 and 0
 Bits indicating the current operating mode

Note: * Determined by pins MD₁ and MD₀.

Bits 7 and 6—Reserved: Read-only bits, always read as 1.

Bits 5 to 2—Reserved: Read-only bits, always read as 0.

Bits 1 and 0—Mode Select 1 and 0 (MDS1 and MDS0): These bits indicate the logic levels at pins MD₁ and MD₀ (the current operating mode). MDS1 and MDS0 correspond to MD₁ and MD₀. MDS1 and MDS0 are read-only bits. The mode pin (MD₁ and MD₀) levels are latched when MDCR is read.

3.3 System Control Register (SYSCR)

SYSCR is an 8-bit register that controls the operation of the H8/3004 and H8/3005.

Bit	7	6	5	4	3	2	1	0
	SSBY	STS2	STS1	STS0	UE	NMIEG	—	RAME
Initial value	0	0	0	0	1	0	1	1
Read/Write	R/W	R/W	R/W	R/W	R/W	R/W	—	R/W

Software standby
 Enables transition to software standby mode

Standby timer select 2 to 0
 These bits select the waiting time at recovery from software standby mode

User bit enable
 Selects whether to use UI bit in CCR 6 as a user bit or an interrupt mask bit

NMI edge select
 Selects the valid edge of the NMI input

Reserved bit

RAM enable
 Enables or disables on-chip RAM

Bit 7—Software Standby (SSBY): Enables transition to software standby mode. (For further information about software standby mode see section 14, Power-Down State.)

When software standby mode is exited by an external interrupt, this bit remains set to 1. To clear this bit, write 0.

Bit 7	SSBY		Description
0			SLEEP instruction causes transition to sleep mode (Initial value)
1			SLEEP instruction causes transition to software standby mode

Bits 6 to 4—Standby Timer Select (STS2 to STS0): These bits select the length of time the CPU and on-chip supporting modules wait for the internal clock oscillator to settle when software standby mode is exited by an external interrupt. Set these bits so that the waiting time will be at least 8 ms at the system clock rate. For further information about waiting time selection, see section 14.4.3, Selection of Waiting Time for Exit from Software Standby Mode.

Bit 6 STS2	Bit 5 STS1	Bit 4 STS0	Description
0	0	0	Waiting time = 8192 states (Initial value)
0	0	1	Waiting time = 16384 states
0	1	0	Waiting time = 32768 states
0	1	1	Waiting time = 65536 states
1	0	—	Waiting time = 131072 states
1	1	—	Illegal setting

Bit 3—User Bit Enable (UE): Selects whether to use the UI bit in the condition code register as a user bit or an interrupt mask bit.

Bit 3 UE	Description
0	UI bit in CCR is used as an interrupt mask bit
1	UI bit in CCR is used as a user bit (Initial value)

Bit 2—NMI Edge Select (NMIEG): Selects the valid edge of the NMI input.

Bit 2 NMIEG	Description
0	An interrupt is requested at the falling edge of NMI (Initial value)
1	An interrupt is requested at the rising edge of NMI

Bit 1—Reserved: Read-only bit, always read as 1.

Bit 0—RAM Enable (RAME): Enables or disables the on-chip RAM. The RAME bit is initialized by the rising edge of the RES signal. It is not initialized in software standby mode.

Bit 0 RAME	Description
0	On-chip RAM is disabled
1	On-chip RAM is enabled (Initial value)

3.4 Operating Mode Descriptions

3.4.1 Mode 1

Address pins A_{19} to A_0 are enabled, and a maximum 1-Mbyte address space can be accessed.

3.4.2 Mode 3

Address pins A_{23} to A_0 are enabled, and a maximum 16-Mbyte address space can be accessed.

3.5 Memory Map in Each Operating Mode

Figure 3-1 shows a memory map of H8/3004. Figure 3-2 shows a memory map of H8/3005. The address space is divided into eight areas.

The on-chip RAM and internal I/O register layout differs between mode 1 (1-Mbyte mode) and mode 3 (16-Mbyte mode). There is also a difference in the range that can be specified by an 8-bit or 16-bit absolute address (@aa:8/@aa:16) in the CPU addressing mode.

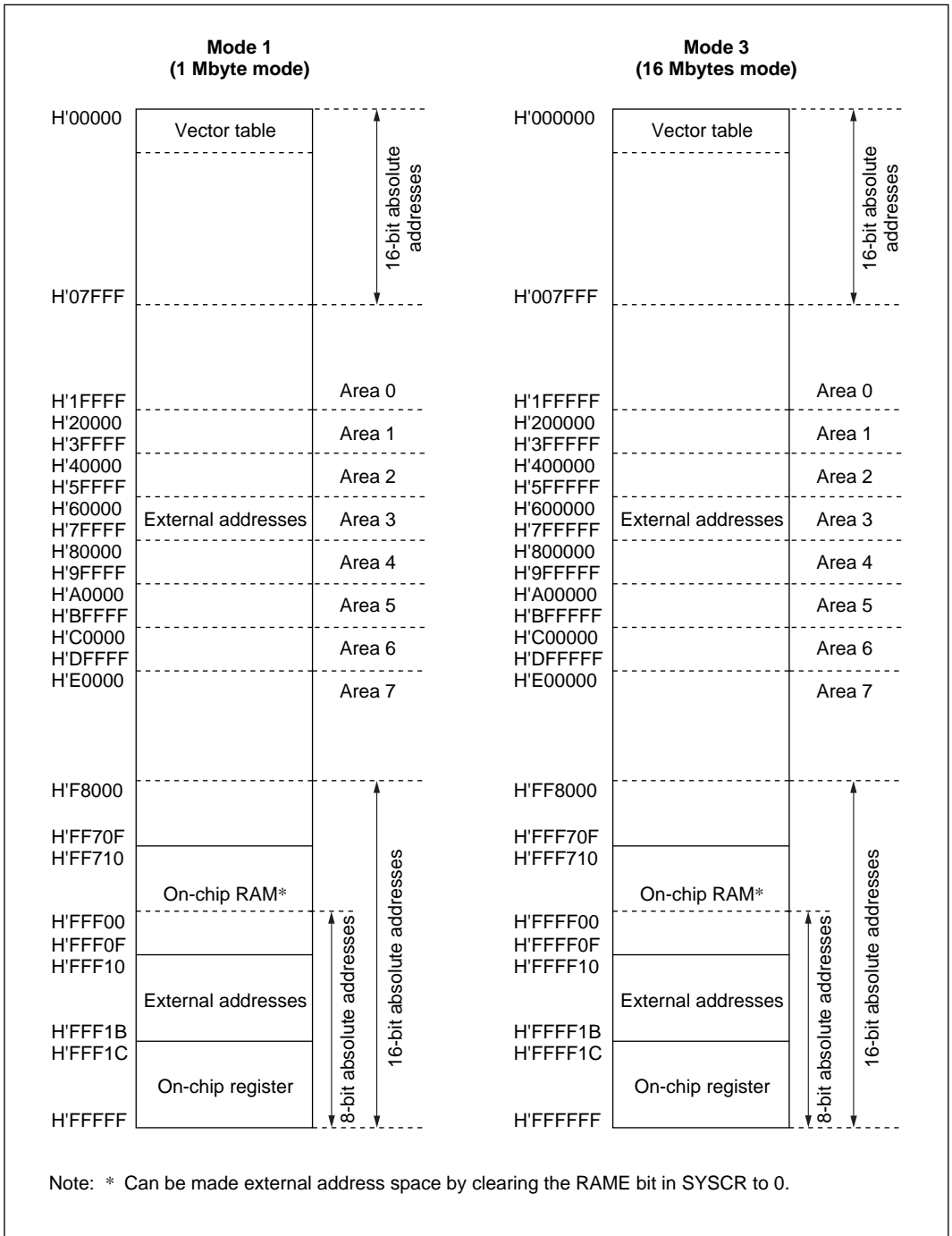

Figure 3-1 H8/3004 Memory Map

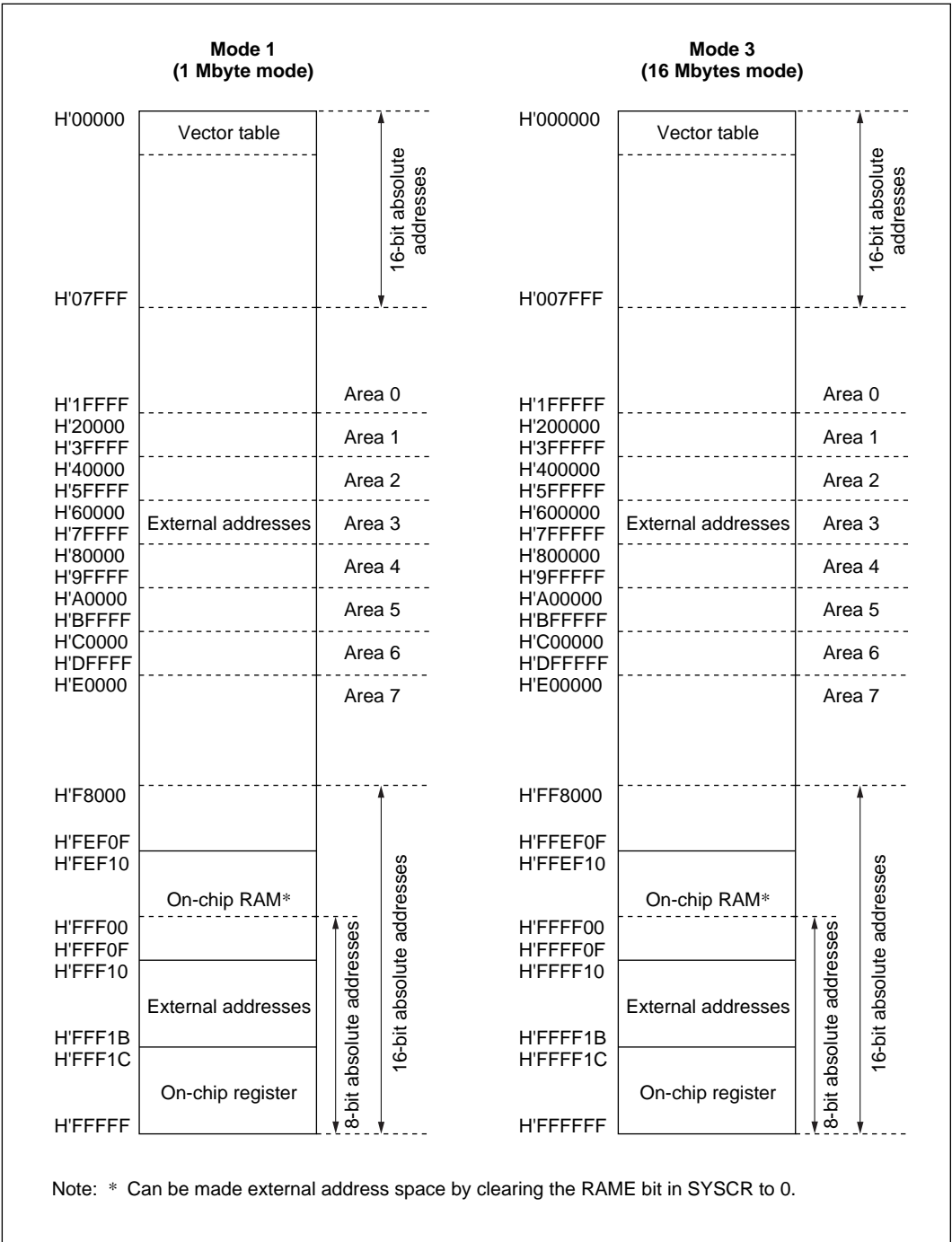

Figure 3-2 H8/3005 Memory Map

Section 4 Exception Handling

4.1 Overview

4.1.1 Exception Handling Types and Priority

As table 4-1 indicates, exception handling may be caused by a reset, trap instruction, or interrupt. Exception handling is prioritized as shown in table 4-1. If two or more exceptions occur simultaneously, they are accepted and processed in priority order. Trap instruction exceptions are accepted at all times in the program execution state.

Table 4-1 Exception Types and Priority

Priority	Exception Type	Start of Exception Handling
High	Reset	Starts immediately after a low-to-high transition at the \overline{RES} pin
↑	Interrupt	Interrupt requests are handled when execution of the current instruction or handling of the current exception is completed
Low	Trap instruction (TRAPA)	Started by execution of a trap instruction (TRAPA)

4.1.2 Exception Handling Operation

Exceptions originate from various sources. Trap instructions and interrupts are handled as follows.

1. The program counter (PC) and condition code register (CCR) are pushed onto the stack.
2. The CCR interrupt mask bit is set to 1.
3. A vector address corresponding to the exception source is generated, and program execution starts from the address indicated in the vector address.

For a reset exception, steps 2 and 3 above are carried out.

4.1.3 Exception Vector Table

The exception sources are classified as shown in figure 4-1. Different vectors are assigned to different exception sources. Table 4-2 lists the exception sources and their vector addresses.

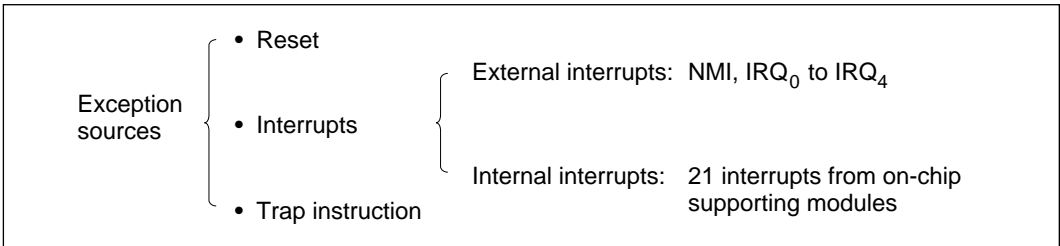

Figure 4-1 Exception Sources

Table 4-2 Exception Vector Table

Exception Source	Vector Number	Vector Address*1	
Reset	0	H'0000 to H'0003	
Reserved for system use	1	H'0004 to H'0007	
	2	H'0008 to H'000B	
	3	H'000C to H'000F	
	4	H'0010 to H'0013	
	5	H'0014 to H'0017	
	6	H'0018 to H'001B	
External interrupt (NMI)	7	H'001C to H'001F	
Trap instruction (4 sources)	8	H'0020 to H'0023	
	9	H'0024 to H'0027	
	10	H'0028 to H'002B	
	11	H'002C to H'002F	
External interrupt	IRQ ₀	12	H'0030 to H'0033
	IRQ ₁	13	H'0034 to H'0037
	IRQ ₂	14	H'0038 to H'003B
	IRQ ₃	15	H'003C to H'003F
	IRQ ₄	16	H'0040 to H'0043
Reserved for system use	17	H'0044 to H'0047	
	18	H'0048 to H'004B	
	19	H'004C to H'004F	
Internal interrupts*2	20	H'0050 to H'0053	
	to 60	to H'00F0 to H'00F3	

Notes: 1. Lower 16 bits of the address.

2. For the internal interrupt vectors, see section 5.3.3, Interrupt Vector Table.

4.2 Reset

4.2.1 Overview

A reset is the highest-priority exception. When the $\overline{\text{RES}}$ pin goes low, all processing halts and the H8/3004 and H8/3005 enter the reset state. A reset initializes the internal state of the CPU and the registers of the on-chip supporting modules. Reset exception handling begins when the $\overline{\text{RES}}$ pin changes from low to high.

The H8/3004 or H8/3005 can also be reset by overflow of the watchdog timer. For details see section 10, Watchdog Timer.

4.2.2 Reset Sequence

The H8/3004 and H8/3005 enters the reset state when the $\overline{\text{RES}}$ pin goes low.

To ensure that the H8/3004 and H8/3005 are reset, hold the $\overline{\text{RES}}$ pin low for at least 20 ms at power-up. To reset the H8/3004 and H8/3005 during operation, hold the $\overline{\text{RES}}$ pin low for at least 10 system clock (ϕ) cycles. See appendix D.2, Pin States at Reset, for the states of the pins in the reset state.

When the $\overline{\text{RES}}$ pin goes high after being held low for the necessary time, the H8/3004 and H8/3005 start reset exception handling as follows.

- The internal state of the CPU and the registers of the on-chip supporting modules are initialized, and the I bit is set to 1 in CCR.
- The contents of the reset vector address (H'0000 to H'0003) are read, and program execution starts from the address indicated in the vector address.

Figure 4-2 shows the reset sequence in modes 1 and 3.

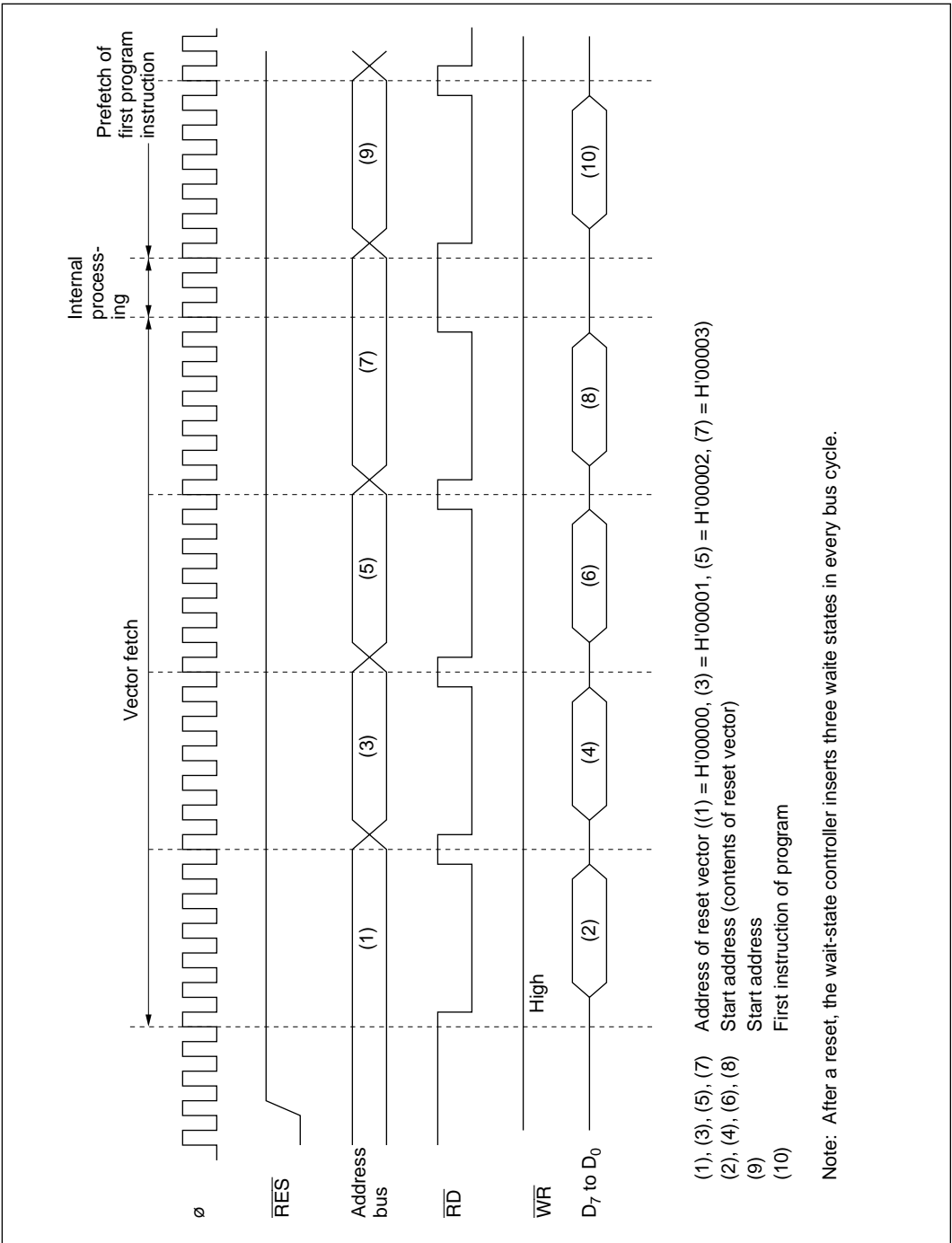

Figure 4-2 Reset Sequence (Mode 1 and 3)

4.2.3 Interrupts after Reset

If an interrupt is accepted after a reset but before the stack pointer (SP) is initialized, PC and CCR will not be saved correctly, leading to a program crash. To prevent this, all interrupt requests, including NMI, are disabled immediately after a reset. The first instruction of the program is always executed immediately after the reset state ends. This instruction should initialize the stack pointer (example: `MOV.L #xx:32, SP`).

4.3 Interrupts

Interrupt exception handling can be requested by nine external sources (NMI, $\overline{\text{IRQ}}_0$ to $\overline{\text{IRQ}}_4$) and 21 internal sources in the on-chip supporting modules. Figure 4-3 classifies the interrupt sources and indicates the number of interrupts of each type.

The on-chip supporting modules that can request interrupts are the watchdog timer (WDT), 16-bit integrated timer unit (ITU), serial communication interface (SCI), and A/D converter. Each interrupt source has a separate vector address.

NMI is the highest-priority interrupt and is always accepted. Interrupts are controlled by the interrupt controller. The interrupt controller can assign interrupts other than NMI to two priority levels, and arbitrate between simultaneous interrupts. Interrupt priorities are assigned in interrupt priority registers A and B (IPRA and IPRB) in the interrupt controller.

For details on interrupts see section 5, Interrupt Controller.

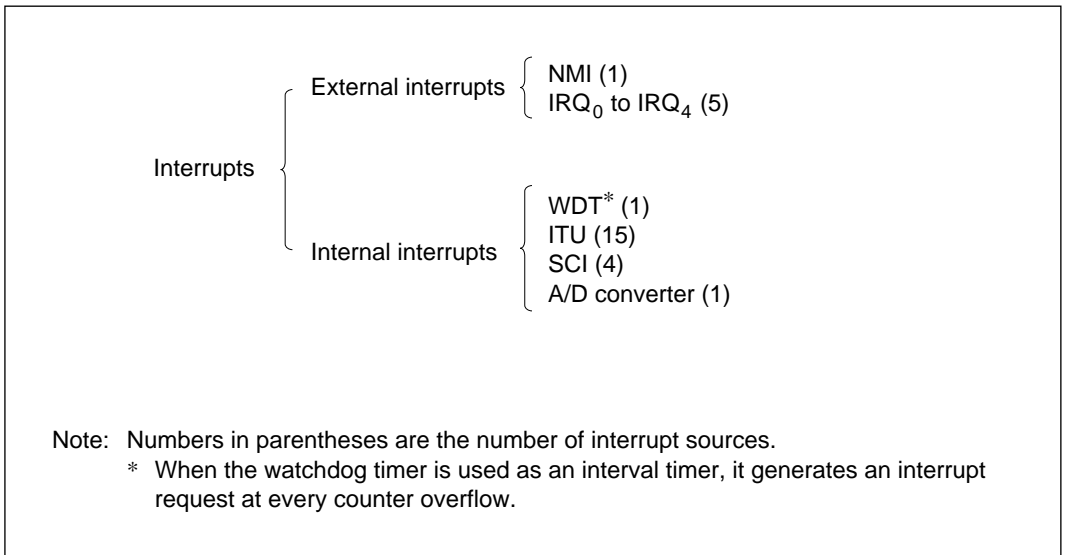

Figure 4-3 Interrupt Sources and Number of Interrupts

4.4 Trap Instruction

Trap instruction exception handling starts when a TRAPA instruction is executed. If the UE bit is set to 1 in the system control register (SYSCR), the exception handling sequence sets the I bit to 1 in CCR. If the UE bit is 0, the I and UI bits are both set to 1. The TRAPA instruction fetches a start address from a vector table entry corresponding to a vector number from 0 to 3, which is specified in the instruction code.

4.5 Stack Status after Exception Handling

Figure 4-4 shows the stack after completion of trap instruction exception handling and interrupt exception handling.

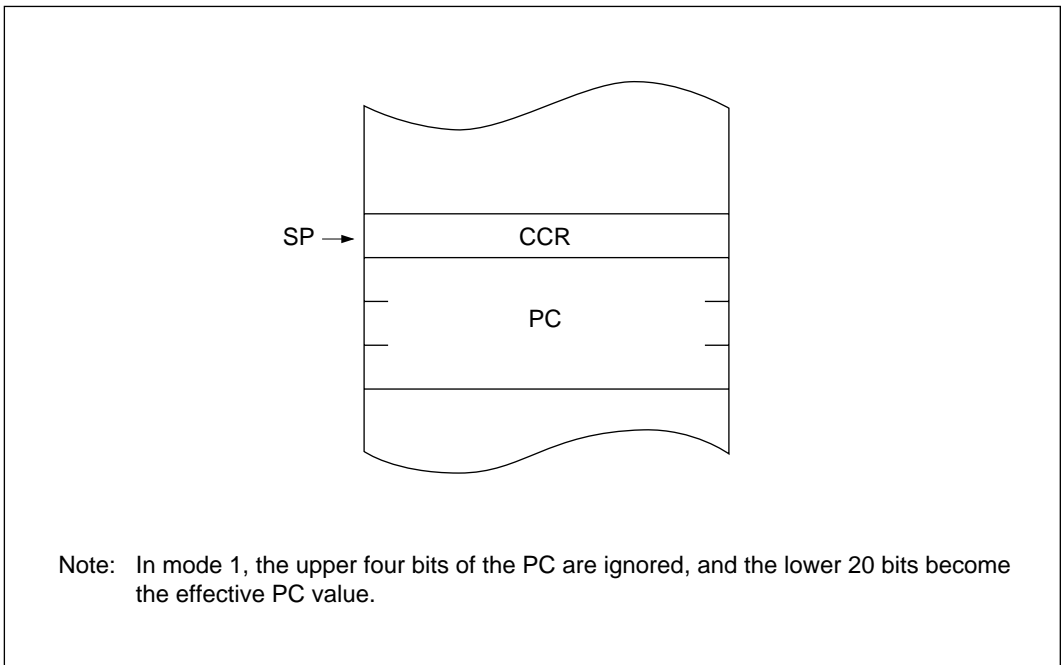

Figure 4-4 Stack after Completion of Exception Handling

4.6 Notes on Stack Usage

When accessing word data or longword data, the H8/3004 and H8/3005 regard the lowest address bit as 0. The stack should always be accessed by word access or longword access, and the value of the stack pointer (SP, ER7) should always be kept even. Use the following instructions to save registers:

PUSH.W Rn (or MOV.W Rn, @-SP)
 PUSH.L ERn (or MOV.L ERn, @-SP)

Use the following instructions to restore registers:

POP.W Rn (or MOV.W @SP+, Rn)
 POP.L ERn (or MOV.L @SP+, ERn)

Setting SP to an odd value may lead to a malfunction. Figure 4-5 shows an example of what happens when the SP value is odd.

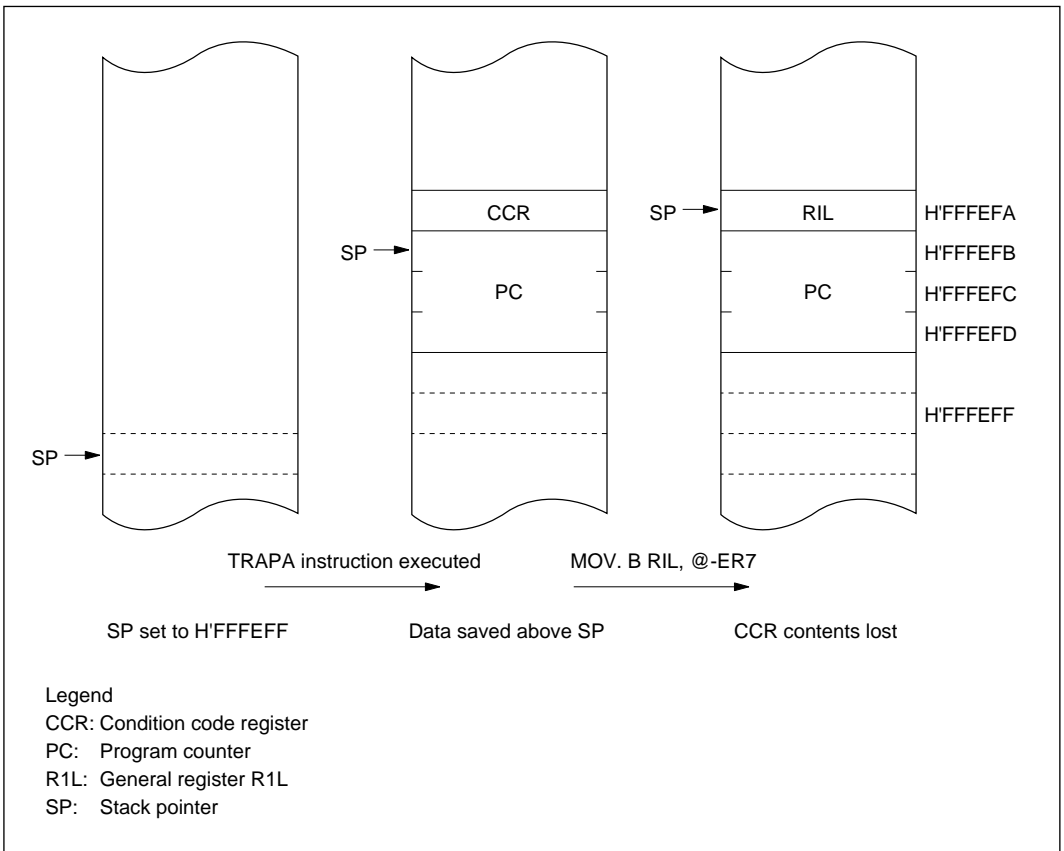

Figure 4-5 Operation when SP Value is Odd

Section 5 Interrupt Controller

5.1 Overview

5.1.1 Features

The interrupt controller has the following features:

- Interrupt priority registers (IPRs) for setting interrupt priorities

Interrupts other than NMI can be assigned to two priority levels on a module-by-module basis in interrupt priority registers A and B (IPRA and IPRB).

- Three-level masking by the I and UI bits in the CPU condition code register (CCR)
- Independent vector addresses

All interrupts are independently vectored; the interrupt service routine does not have to identify the interrupt source.

- Six external interrupt pins

NMI has the highest priority and is always accepted; either the rising or falling edge can be selected. For each of IRQ₀ to IRQ₄, sensing of the falling edge or level sensing can be selected independently.

5.1.2 Block Diagram

Figure 5-1 shows a block diagram of the interrupt controller.

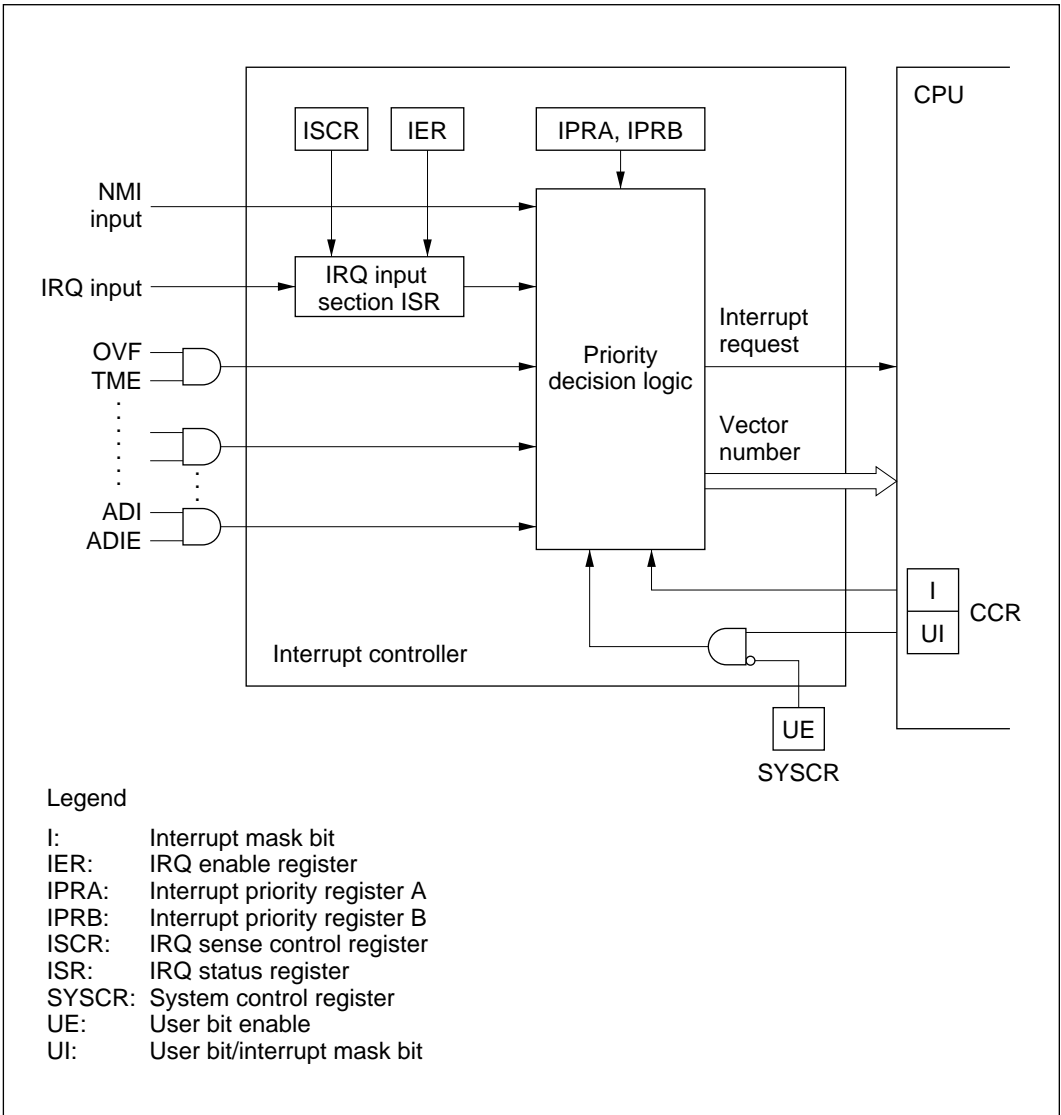

Figure 5-1 Interrupt Controller Block Diagram

5.1.3 Pin Configuration

Table 5-1 lists the interrupt pins.

Table 5-1 Interrupt Pins

Name	Abbreviation	I/O	Function
Nonmaskable interrupt	NMI	Input	Nonmaskable interrupt, rising edge or falling edge selectable
External interrupt request 4 to 0	$\overline{\text{IRQ}}_4$ to $\overline{\text{IRQ}}_0$	Input	Maskable interrupts, falling edge or level sensing selectable

5.1.4 Register Configuration

Table 5-2 lists the registers of the interrupt controller.

Table 5-2 Interrupt Controller Registers

Address* ¹	Name	Abbreviation	R/W	Initial Value
H'FFF2	System control register	SYSCR	R/W	H'0B
H'FFF4	IRQ sense control register	ISCR	R/W	H'00
H'FFF5	IRQ enable register	IER	R/W	H'00
H'FFF6	IRQ status register	ISR	R/(W)* ²	H'00
H'FFF8	Interrupt priority register A	IPRA	R/W	H'00
H'FFF9	Interrupt priority register B	IPRB	R/W	H'00

- Notes: 1. Lower 16 bits of the address.
2. Only 0 can be written, to clear flags.

5.2 Register Descriptions

5.2.1 System Control Register (SYSCR)

SYSCR is an 8-bit readable/writable register that controls software standby mode, selects the action of the UI bit in CCR, selects the NMI edge, and enables or disables the on-chip RAM.

Only bits 3 and 2 are described here. For the other bits, see section 3.3, System Control Register (SYSCR).

SYSCR is initialized to H'0B by a reset and in hardware standby mode. It is not initialized in software standby mode.

Bit	7	6	5	4	3	2	1	0
	SSBY	STS2	STS1	STS0	UE	NMIEG	—	RAME
Initial value	0	0	0	0	1	0	1	1
Read/Write	R/W	R/W	R/W	R/W	R/W	R/W	R/W	R/W

Software standby

**Standby timer
select 2 to 0**

User bit enable
Selects whether to use CCR bit 6
as a user bit or interrupt mask bit

NMI edge select
Selects the NMI input edge

Reserved bit

RAM enable

Bit 3—User Bit Enable (UE): Selects whether to use the UI bit in CCR as a user bit or an interrupt mask bit.

Bit 3

UE	Description	
0	UI bit in CCR is used as interrupt mask bit	
1	UI bit in CCR is used as user bit	(Initial value)

Bit 2—NMI Edge Select (NMIEG): Selects the NMI input edge.

Bit 2

NMIEG	Description	
0	Interrupt is requested at falling edge of NMI input	(Initial value)
1	Interrupt is requested at rising edge of NMI input	

5.2.2 Interrupt Priority Registers A and B (IPRA, IPRB)

IPRA and IPRB are 8-bit readable/writable registers that control interrupt priority.

Interrupt Priority Register A (IPRA): IPRA is an 8-bit readable/writable register in which interrupt priority levels can be set.

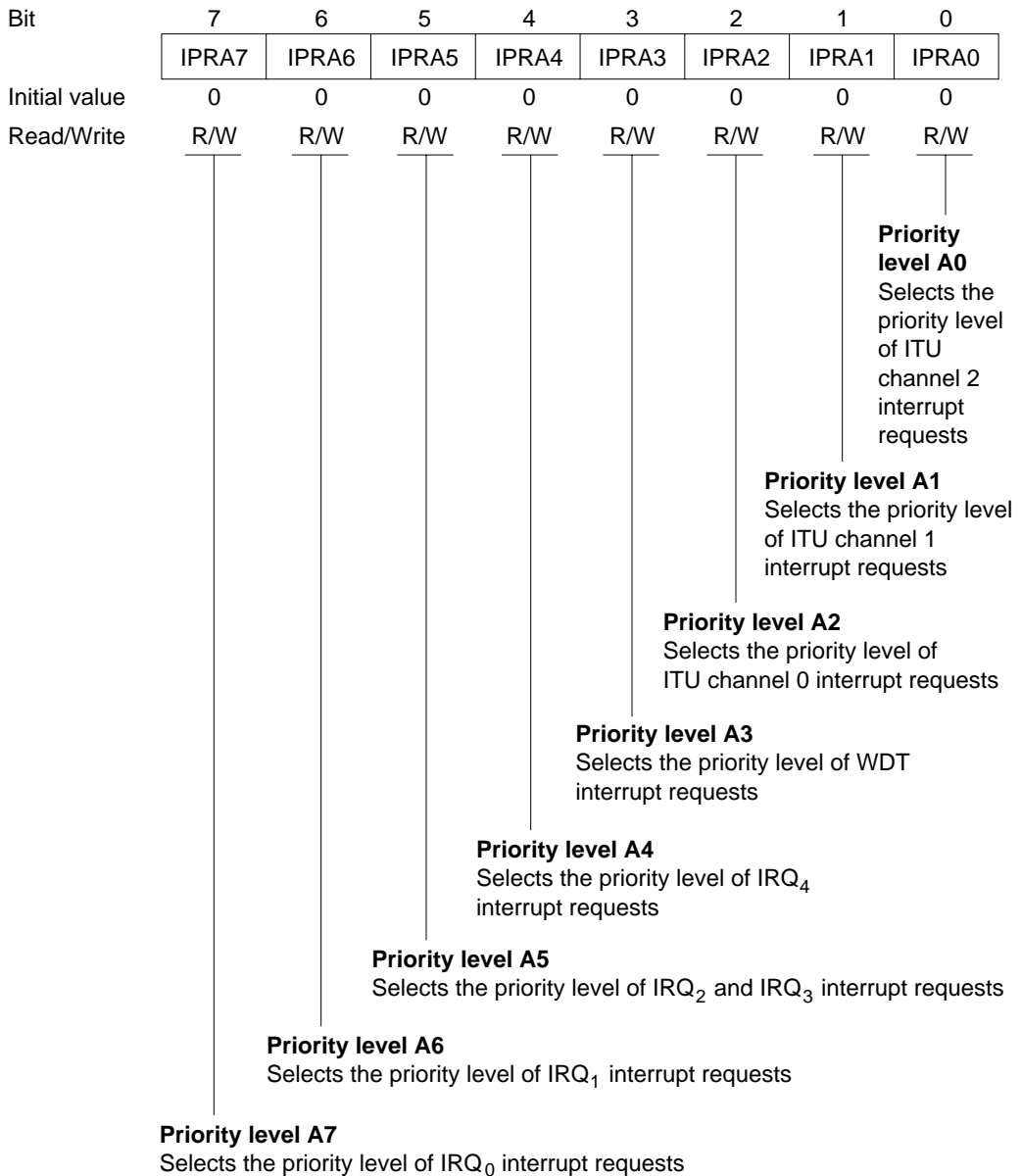

IPRA is initialized to H'00 by a reset and in hardware standby mode.

Bit 7—Priority Level A7 (IPRA7): Selects the priority level of IRQ₀ interrupt requests.

Bit 7

IPRA7	Description	
0	IRQ ₀ interrupt requests have priority level 0 (low priority)	(Initial value)
1	IRQ ₀ interrupt requests have priority level 1 (high priority)	

Bit 6—Priority Level A6 (IPRA6): Selects the priority level of IRQ₁ interrupt requests.

Bit 6

IPRA6	Description	
0	IRQ ₁ interrupt requests have priority level 0 (low priority)	(Initial value)
1	IRQ ₁ interrupt requests have priority level 1 (high priority)	

Bit 5—Priority Level A5 (IPRA5): Selects the priority level of IRQ₂ and IRQ₃ interrupt requests.

Bit 5

IPRA5	Description	
0	IRQ ₂ and IRQ ₃ interrupt requests have priority level 0 (low priority)	(Initial value)
1	IRQ ₂ and IRQ ₃ interrupt requests have priority level 1 (high priority)	

Bit 4—Priority Level A4 (IPRA4): Selects the priority level of IRQ₄ interrupt requests.

Bit 4

IPRA4	Description	
0	IRQ ₄ interrupt requests have priority level 0 (low priority)	(Initial value)
1	IRQ ₄ interrupt requests have priority level 1 (high priority)	

Bit 3—Priority Level A3 (IPRA3): Selects the priority level of WDT interrupt requests.

Bit 3

IPRA3	Description	
0	WDT interrupt requests have priority level 0 (low priority)	(Initial value)
1	WDT interrupt requests have priority level 1 (high priority)	

Bit 2—Priority Level A2 (IPRA2): Selects the priority level of ITU channel 0 interrupt requests.

Bit 2

IPRA2	Description	
0	ITU channel 0 interrupt requests have priority level 0 (low priority)	(Initial value)
1	ITU channel 0 interrupt requests have priority level 1 (high priority)	

Bit 1—Priority Level A1 (IPRA1): Selects the priority level of ITU channel 1 interrupt requests.

Bit 1

IPRA1	Description	
0	ITU channel 1 interrupt requests have priority level 0 (low priority)	(Initial value)
1	ITU channel 1 interrupt requests have priority level 1 (high priority)	

Bit 0—Priority Level A0 (IPRA0): Selects the priority level of ITU channel 2 interrupt requests.

Bit 0

IPRA0	Description	
0	ITU channel 2 interrupt requests have priority level 0 (low priority)	(Initial value)
1	ITU channel 2 interrupt requests have priority level 1 (high priority)	

Interrupt Priority Register B (IPRB): IPRB is an 8-bit readable/writable register in which interrupt priority levels can be set.

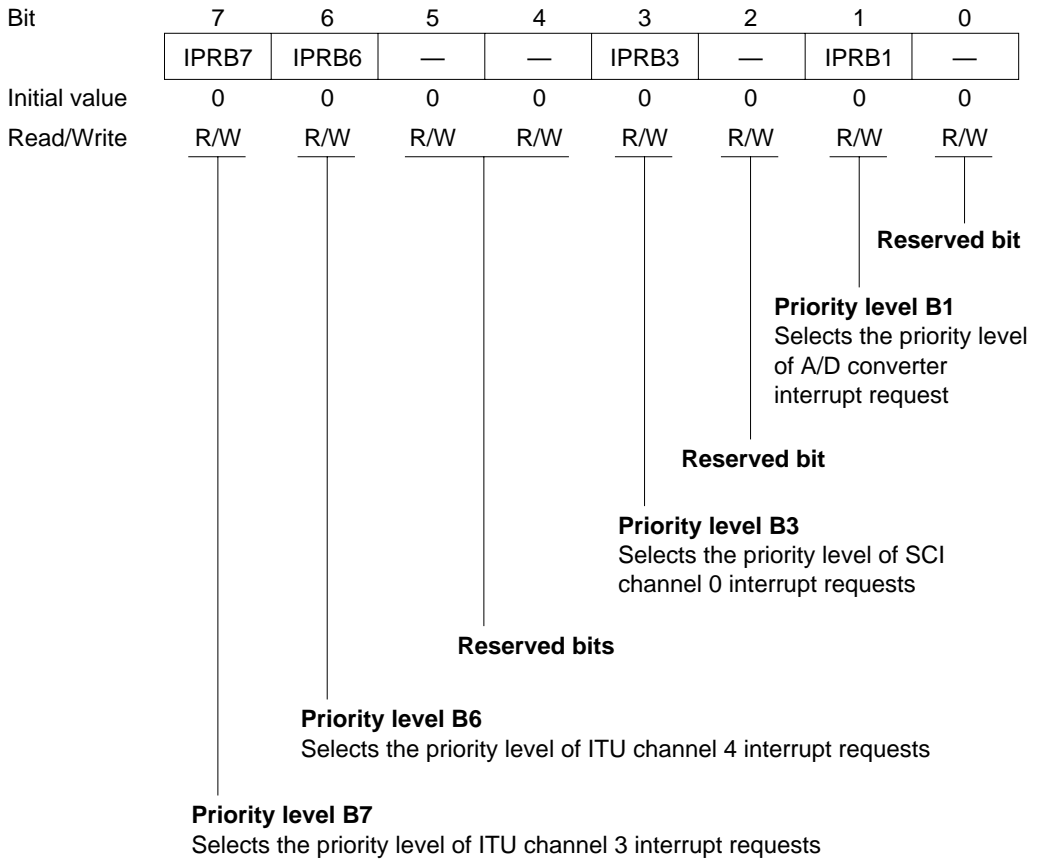

IPRB is initialized to H'00 by a reset and in hardware standby mode.

Bit 7—Priority Level B7 (IPRB7): Selects the priority level of ITU channel 3 interrupt requests.

Bit 7 IPRB7	Description
0	ITU channel 3 interrupt requests have priority level 0 (low priority) (Initial value)
1	ITU channel 3 interrupt requests have priority level 1 (high priority)

Bit 6—Priority Level B6 (IPRB6): Selects the priority level of ITU channel 4 interrupt requests.

Bit 6 IPRB6	Description
0	ITU channel 4 interrupt requests have priority level 0 (low priority) (Initial value)
1	ITU channel 4 interrupt requests have priority level 1 (high priority)

Bits 5 and 4—Reserved: These bits can be written and read, but it does not affect interrupt priority.

Bit 3—Priority Level B3 (IPRB3): Selects the priority level of SCI interrupt requests.

Bit 3 IPRB3	Description
0	SCI interrupt requests have priority level 0 (low priority) (Initial value)
1	SCI interrupt requests have priority level 1 (high priority)

Bit 2—Reserved: This bit can be written and read, but it does not affect interrupt priority.

Bit 1—Priority Level B1 (IPRB1): Selects the priority level of A/D converter interrupt requests.

Bit 1 IPRB1	Description
0	A/D converter interrupt requests have priority level 0 (low priority) (Initial value)
1	A/D converter interrupt requests have priority level 1 (high priority)

Bit 0—Reserved: This bit can be written and read, but it does not affect interrupt priority.

5.2.3 IRQ Status Register (ISR)

ISR is an 8-bit readable/writable register that indicates the status of IRQ₀ to IRQ₄ interrupt requests.

Bit	7	6	5	4	3	2	1	0
	—	—	—	IRQ4F	IRQ3F	IRQ2F	IRQ1F	IRQ0F
Initial value	0	0	0	0	0	0	0	0
Read/Write	—	—	—	R/(W)*	R/(W)*	R/(W)*	R/(W)*	R/(W)*

Reserved bits
IRQ₄ to IRQ₀ flags
These bits indicate IRQ₄ to IRQ₀ interrupt request status

Note: * Only 0 can be written, to clear flags.

ISR is initialized to H'00 by a reset and in hardware standby mode.

Bits 7 to 5—Reserved: Read-only bits, always read as 0.

Bits 4 to 0—IRQ₄ to IRQ₀ Flags (IRQ4F to IRQ0F): These bits indicate the status of IRQ₄ to IRQ₀ interrupt requests.

Bits 4 to 0

IRQ4F to IRQ0F	Description
0	[Clearing conditions] (Initial value) 0 is written in IRQ _n F after reading the IRQ _n F flag when IRQ _n F = 1. IRQ _n SC = 0, $\overline{\text{IRQ}}_n$ input is high, and interrupt exception handling is carried out. IRQ _n SC = 1 and IRQ _n interrupt exception handling is carried out.
1	[Setting conditions] IRQ _n SC = 0 and $\overline{\text{IRQ}}_n$ input is low. IRQ _n SC = 1 and $\overline{\text{IRQ}}_n$ input changes from high to low.

Note: n = 4 to 0

5.2.4 IRQ Enable Register (IER)

IER is an 8-bit readable/writable register that enables or disables IRQ₀ to IRQ₄ interrupt requests.

Bit	7	6	5	4	3	2	1	0
	—	—	—	IRQ4E	IRQ3E	IRQ2E	IRQ1E	IRQ0E
Initial value	0	0	0	0	0	0	0	0
Read/Write	R/W	R/W	R/W	R/W	R/W	R/W	R/W	R/W

Reserved bits
IRQ₄ to IRQ₀ enable
 These bits enable or disable
 IRQ₄ to IRQ₀ interrupts

IER is initialized to H'00 by a reset and in hardware standby mode.

Bits 7 to 5—Reserved: These bits can be written and read, but they do not enable or disable interrupts.

Bits 4 to 0—IRQ₄ to IRQ₀ Enable (IRQ7E to IRQ0E): These bits enable or disable IRQ₄ to IRQ₀ interrupts.

Bits 4 to 0

IRQ4E to IRQ0E	Description
0	IRQ ₄ to IRQ ₀ interrupts are disabled (Initial value)
1	IRQ ₄ to IRQ ₀ interrupts are enabled

5.2.5 IRQ Sense Control Register (ISCR)

ISCR is an 8-bit readable/writable register that selects level sensing or falling-edge sensing of the inputs at pins $\overline{\text{IRQ}}_4$ to $\overline{\text{IRQ}}_0$.

Bit	7	6	5	4	3	2	1	0
	—	—	—	IRQ4SC	IRQ3SC	IRQ2SC	IRQ1SC	IRQ0SC
Initial value	0	0	0	0	0	0	0	0
Read/Write	R/W	R/W	R/W	R/W	R/W	R/W	R/W	R/W

Reserved bit
IRQ₄ to IRQ₀ sense control
 These bits select level sensing or falling-edge sensing for IRQ₄ to IRQ₀ interrupts

ISCR is initialized to H'00 by a reset and in hardware standby mode.

Bits 7 to 5—Reserved: These bits can be written and read, but they do not select level or falling-edge sensing.

Bits 4 to 0—IRQ₄ to IRQ₀ Sense Control (IRQ4SC to IRQ0SC): These bits select whether interrupts IRQ₄ to IRQ₀ are requested by level sensing of pins $\overline{\text{IRQ}}_4$ to $\overline{\text{IRQ}}_0$, or by falling-edge sensing.

Bits 4 to 0

IRQ4SC to IRQ0SC Description

0	Interrupts are requested when $\overline{\text{IRQ}}_4$ to $\overline{\text{IRQ}}_0$ inputs are low	(Initial value)
1	Interrupts are requested by falling-edge input at $\overline{\text{IRQ}}_4$ to $\overline{\text{IRQ}}_0$	

5.3 Interrupt Sources

The interrupt sources include external interrupts (NMI, IRQ₀ to IRQ₄) and 21 internal interrupts.

5.3.1 External Interrupts

There are six external interrupts: NMI, and IRQ₀ to IRQ₄. Of these, NMI, IRQ₀, IRQ₁, and IRQ₂ can be used to exit software standby mode.

NMI: NMI is the highest-priority interrupt and is always accepted, regardless of the states of the I and UI bits in CCR. The NMIEG bit in SYSCR selects whether an interrupt is requested by the rising or falling edge of the input at the NMI pin. NMI interrupt exception handling has vector number 7.

IRQ₀ to IRQ₄ Interrupts: These interrupts are requested by input signals at pins $\overline{\text{IRQ}}_0$ to $\overline{\text{IRQ}}_4$. The IRQ₀ to IRQ₄ interrupts have the following features.

- ISCR settings can select whether an interrupt is requested by the low level of the input at pins $\overline{\text{IRQ}}_0$ to $\overline{\text{IRQ}}_4$, or by the falling edge.
- IER settings can enable or disable the IRQ₀ to IRQ₄ interrupts. Interrupt priority levels can be assigned by four bits in IPRA (IPRA7 to IPRA4).
- The status of IRQ₀ to IRQ₄ interrupt requests is indicated in ISR. The ISR flags can be cleared to 0 by software.

Figure 5-2 shows a block diagram of interrupts IRQ₀ to IRQ₄.

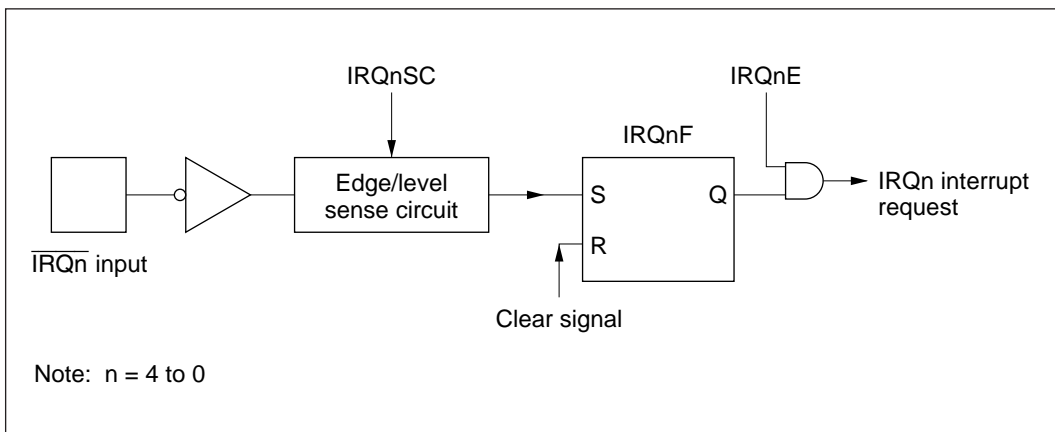

Figure 5-2 Block Diagram of Interrupts IRQ₀ to IRQ₄

Figure 5-3 shows the timing of the setting of the interrupt flags (IRQnF).

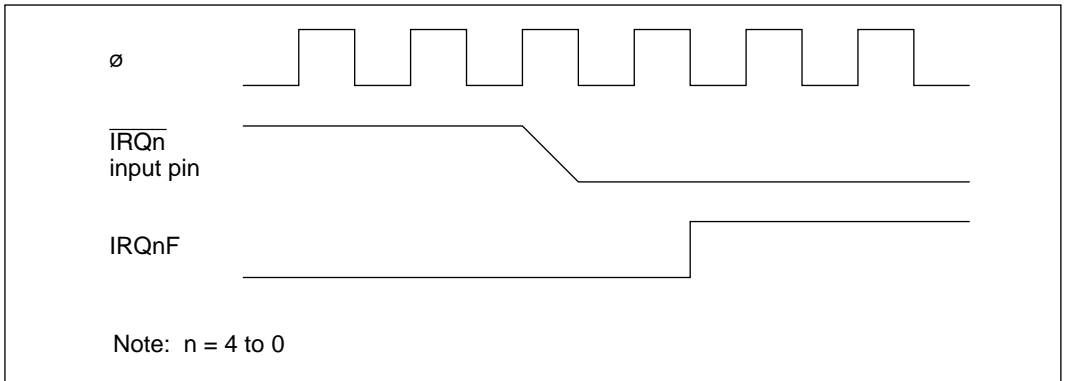

Figure 5-3 Timing of Setting of IRQnF

Interrupts IRQ₀ to IRQ₄ have vector numbers 12 to 16. These interrupts are detected regardless of whether the corresponding pin is set for input or output. When using a pin for external interrupt input, clear its DDR bit to 0 and do not use the pin for SCI input or output.

5.3.2 Internal Interrupts

Twenty-one internal interrupts are requested from the on-chip supporting modules.

- Each on-chip supporting module has status flags for indicating interrupt status, and enable bits for enabling or disabling interrupts.
- Interrupt priority levels can be assigned in IPRA and IPRB.

5.3.3 Interrupt Vector Table

Table 5-3 lists the interrupt sources, their vector addresses, and their default priority order. In the default priority order, smaller vector numbers have higher priority. The priority of interrupts other than NMI can be changed in IPRA and IPRB. The priority order after a reset is the default order shown in table 5-3.

Table 5-3 Interrupt Sources, Vector Addresses, and Priority

Interrupt Source	Origin	Vector Number	Vector Address*	IPR	Priority
NMI	External pins	7	H'001C to H'001F	—	High
IRQ ₀		12	H'0030 to H'0033	IPRA7	↑
IRQ ₁		13	H'0034 to H'0037	IPRA6	
IRQ ₂		14	H'0038 to H'003B	IPRA5	
IRQ ₃		15	H'003C to H'003F		
IRQ ₄		16	H'0040 to H'0043	IPRA4	
Reserved	—	17	H'0044 to H'0047		
		18	H'0048 to H'004B		
		19	H'004C to H'004F		
WOVI (interval timer)	Watchdog timer	20	H'0050 to H'0053	IPRA3	
Reserved	—	21	H'0054 to H'0057		
		22	H'0058 to H'005B		
		23	H'005C to H'005F		
IMIA0 (compare match/ input capture A0)	ITU channel 0	24	H'0060 to H'0063	IPRA2	
IMIB0 (compare match/ input capture B0)		25	H'0064 to H'0067		
OVI0 (overflow 0)		26	H'0068 to H'006B		
Reserved	—	27	H'006C to H'006F		
IMIA1 (compare match/ input capture A1)	ITU channel 1	28	H'0070 to H'0073	IPRA1	
IMIB1 (compare match/ input capture B1)		29	H'0074 to H'0077		
OVI1 (overflow 1)		30	H'0078 to H'007B		
Reserved	—	31	H'007C to H'007F		
IMIA2 (compare match/ input capture A2)	ITU channel 2	32	H'0080 to H'0083	IPRA0	
IMIB2 (compare match/ input capture B2)		33	H'0084 to H'0087		
OVI2 (overflow 2)		34	H'0088 to H'008B		
Reserved	—	35	H'008C to H'008F		

Note: * Lower 16 bits of the address.

Table 5-3 Interrupt Sources, Vector Addresses, and Priority (cont)

Interrupt Source	Origin	Vector Number	Vector Address*	IPR	Priority
IMIA3 (compare match/ input capture A3)	ITU channel 3	36	H'0090 to H'0093	IPRB7	↑
IMIB3 (compare match/ input capture B3)		37	H'0094 to H'0097		
OVI3 (overflow 3)		38	H'0098 to H'009B		
Reserved	—	39	H'009C to H'009F		
IMIA4 (compare match/ input capture A4)	ITU channel 4	40	H'00A0 to H'00A3	IPRB6	
IMIB4 (compare match/ input capture B4)		41	H'00A4 to H'00A7		
OVI4 (overflow 4)		42	H'00A8 to H'00AB		
Reserved	—	43	H'00AC to H'00AF		
Reserved	—	44	H'00B0 to H'00B3	—	
		45	H'00B4 to H'00B7		
		46	H'00B8 to H'00BB		
		47	H'00BC to H'00BF		
		48	H'00C0 to H'00C3		
		49	H'00C4 to H'00C7		
		50	H'00C8 to H'00CB		
		51	H'00CC to H'00CF		
ERIO (receive error)	SCI	52	H'00D0 to H'00D3	IPRB3	
RXIO (receive data full)		53	H'00D4 to H'00D7		
TXIO (transmit data empty)		54	H'00D8 to H'00DB		
TEIO (transmit end)		55	H'00DC to H'00DF		
Reserved	—	56	H'00E0 to H'00E3	—	
		57	H'00E4 to H'00E7		
		58	H'00E8 to H'00EB		
		59	H'00EC to H'00EF		
ADI (A/D end)	A/D	60	H'00F0 to H'00F3	IPRB1	Low

Note: * Lower 16 bits of the address.

5.4 Interrupt Operation

5.4.1 Interrupt Handling Process

The H8/3004 and H8/3005 handle interrupts differently depending on the setting of the UE bit. When UE = 1, interrupts are controlled by the I bit. When UE = 0, interrupts are controlled by the I and UI bits. Table 5-4 indicates how interrupts are handled for all setting combinations of the UE, I, and UI bits.

NMI interrupts are always accepted except in the reset and hardware standby states. IRQ interrupts and interrupts from the on-chip supporting modules have their own enable bits. Interrupt requests are ignored when the enable bits are cleared to 0.

Table 5-4 UE, I, and UI Bit Settings and Interrupt Handling

SYSCR	CCR		Description
	UE	I UI	
1	0	—	All interrupts are accepted. Interrupts with priority level 1 have higher priority.
	1	—	No interrupts are accepted except NMI.
0	0	—	All interrupts are accepted. Interrupts with priority level 1 have higher priority.
	1	0	NMI and interrupts with priority level 1 are accepted.
		1	No interrupts are accepted except NMI.

UE = 1: Interrupts IRQ₀ to IRQ₄ and interrupts from the on-chip supporting modules can all be masked by the I bit in the CPU's CCR. Interrupts are masked when the I bit is set to 1, and unmasked when the I bit is cleared to 0. Interrupts with priority level 1 have higher priority. Figure 5-4 is a flowchart showing how interrupts are accepted when UE = 1.

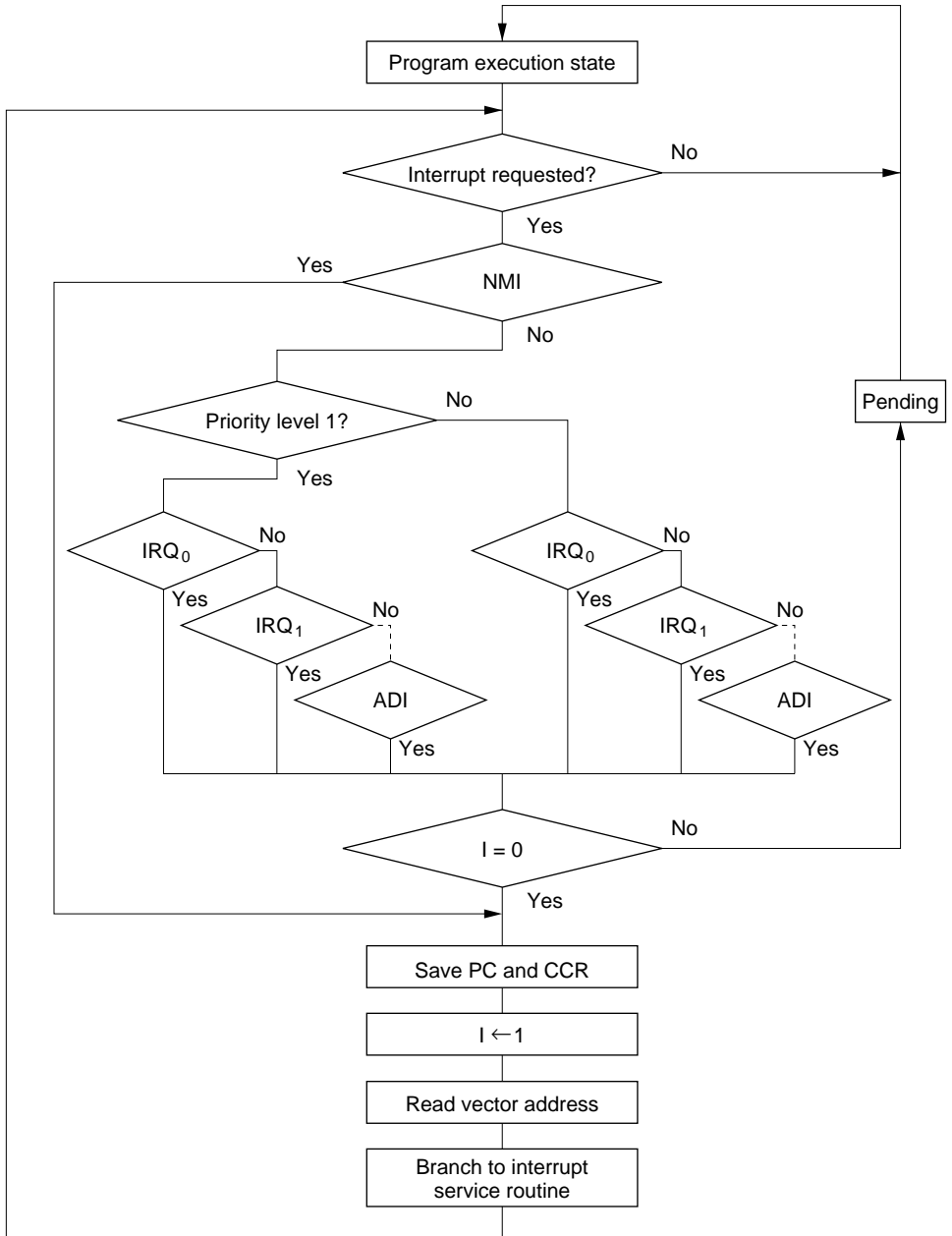

Figure 5-4 Process Up to Interrupt Acceptance when UE = 1

- If an interrupt condition occurs and the corresponding interrupt enable bit is set to 1, an interrupt request is sent to the interrupt controller.
- When the interrupt controller receives one or more interrupt requests, it selects the highest-priority request, following the IPR interrupt priority settings, and holds other requests pending. If two or more interrupts with the same IPR setting are requested simultaneously, the interrupt controller follows the priority order shown in table 5-3.
- The interrupt controller checks the I bit. If the I bit is cleared to 0, the selected interrupt request is accepted. If the I bit is set to 1, only NMI is accepted; other interrupt requests are held pending.
- When an interrupt request is accepted, interrupt exception handling starts after execution of the current instruction has been completed.
- In interrupt exception handling, PC and CCR are saved to the stack area. The PC value that is saved indicates the address of the first instruction that will be executed after the return from the interrupt service routine.
- Next the I bit is set to 1 in CCR, masking all interrupts except NMI.
- The vector address of the accepted interrupt is generated, and the interrupt service routine starts executing from the address indicated by the contents of the vector address.

UE = 0: The I and UI bits in the CPU's CCR and the IPR bits enable three-level masking of IRQ₀ to IRQ₄ interrupts and interrupts from the on-chip supporting modules.

- Interrupt requests with priority level 0 are masked when the I bit is set to 1, and are unmasked when the I bit is cleared to 0.
- Interrupt requests with priority level 1 are masked when the I and UI bits are both set to 1, and are unmasked when either the I bit or the UI bit is cleared to 0.

For example, if the interrupt enable bits of all interrupt requests are set to 1, IPRA is set to H'20, and IPRB is set to H'00 (giving IRQ₂ and IRQ₃ interrupt requests priority over other interrupts), interrupts are masked as follows:

- a. If I = 0, all interrupts are unmasked (priority order: NMI > IRQ₂ > IRQ₃ > IRQ₀ ...).
- b. If I = 1 and UI = 0, only NMI, IRQ₂, and IRQ₃ are unmasked.
- c. If I = 1 and UI = 1, all interrupts are masked except NMI.

Figure 5-5 shows the transitions among the above states.

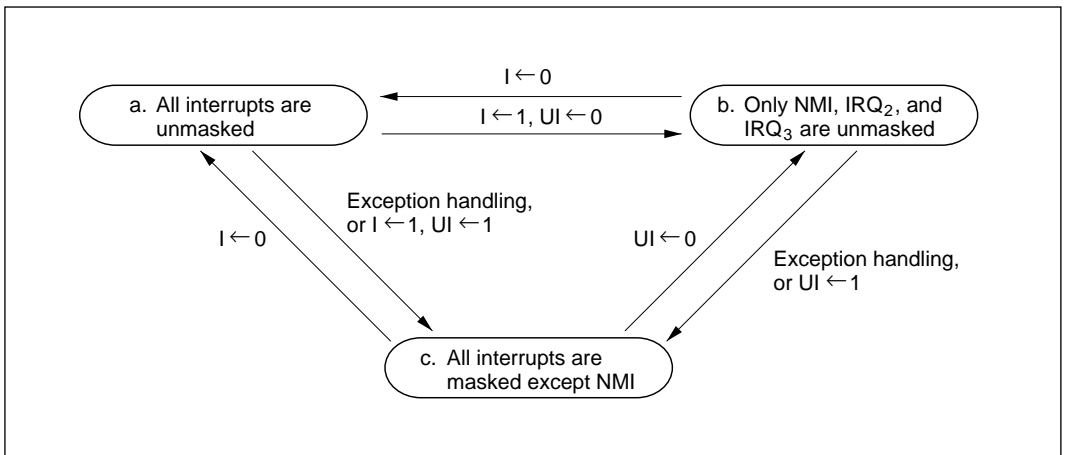

Figure 5-5 Interrupt Masking State Transitions (Example)

Figure 5-6 is a flowchart showing how interrupts are accepted when UE = 0.

- If an interrupt condition occurs and the corresponding interrupt enable bit is set to 1, an interrupt request is sent to the interrupt controller.
- When the interrupt controller receives one or more interrupt requests, it selects the highest-priority request, following the IPR interrupt priority settings, and holds other requests pending. If two or more interrupts with the same IPR setting are requested simultaneously, the interrupt controller follows the priority order shown in table 5-3.
- The interrupt controller checks the I bit. If the I bit is cleared to 0, the selected interrupt request is accepted regardless of its IPR setting, and regardless of the UI bit. If the I bit is set to 1 and the UI bit is cleared to 0, only NMI and interrupts with priority level 1 are accepted; interrupt requests with priority level 0 are held pending. If the I bit and UI bit are both set to 1, only NMI is accepted; all other interrupt requests are held pending.
- When an interrupt request is accepted, interrupt exception handling starts after execution of the current instruction has been completed.
- In interrupt exception handling, PC and CCR are saved to the stack area. The PC value that is saved indicates the address of the first instruction that will be executed after the return from the interrupt service routine.
- The I and UI bits are set to 1 in CCR, masking all interrupts except NMI.
- The vector address of the accepted interrupt is generated, and the interrupt service routine starts executing from the address indicated by the contents of the vector address.

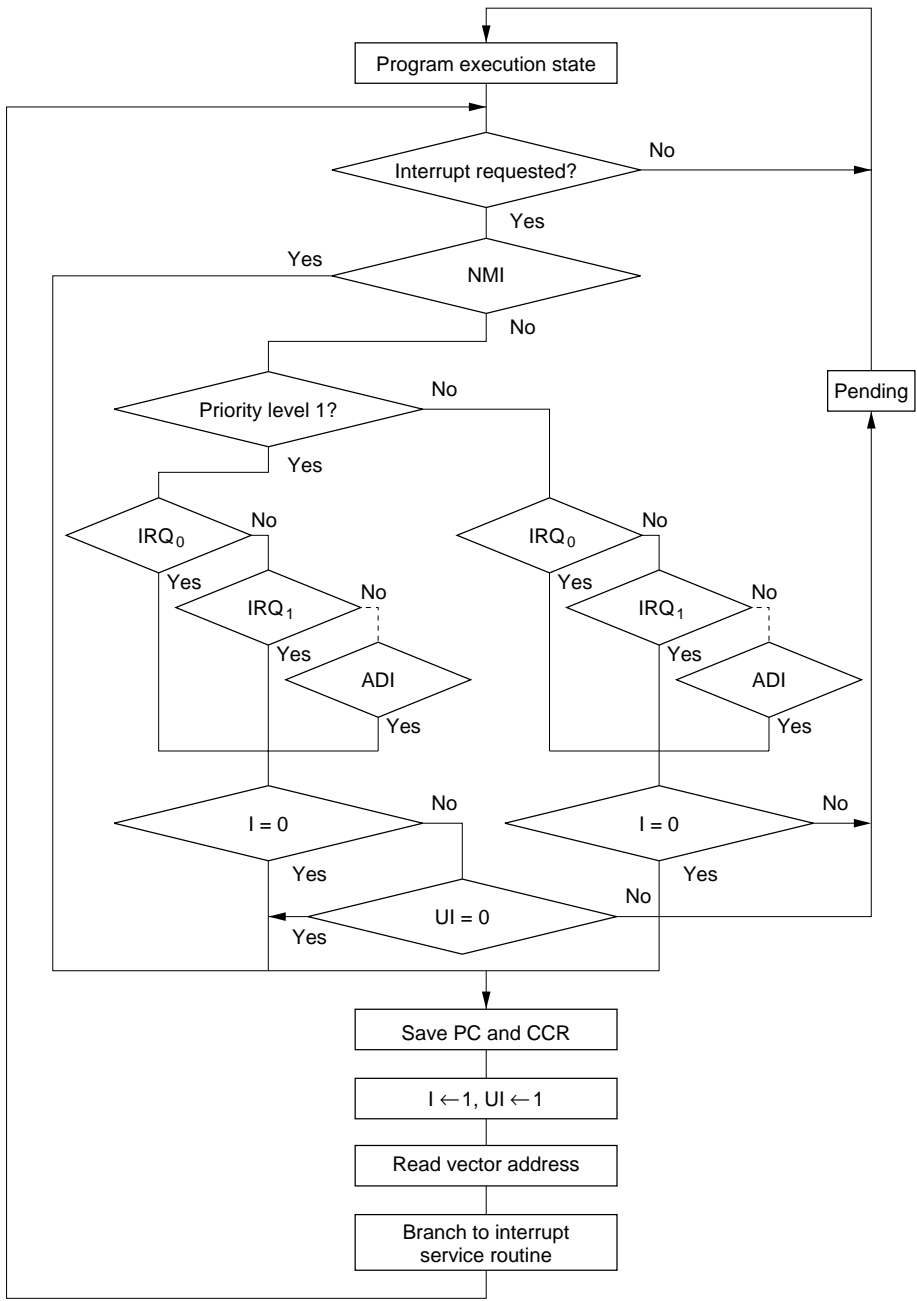

Figure 5-6 Process Up to Interrupt Acceptance when UE = 0

5.4.2 Interrupt Sequence

Figure 5-7 shows the interrupt sequence in mode 1 when the program code and stack are in an external memory area.

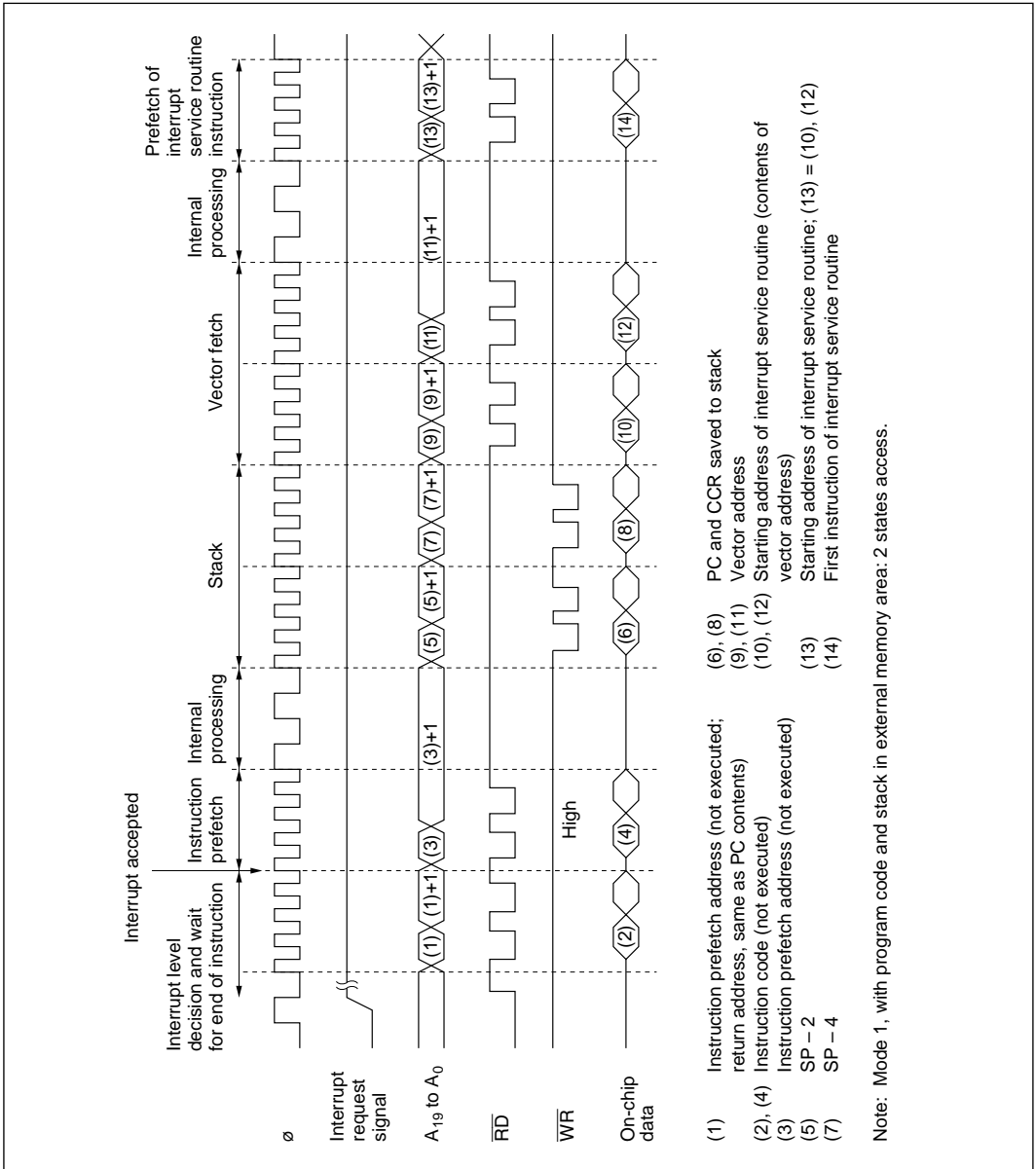

Figure 5-7 Interrupt Sequence (Mode 1, Stack in External Memory: 2 States Access)

5.4.3 Interrupt Response Time

Table 5-5 indicates the interrupt response time from the occurrence of an interrupt request until the first instruction of the interrupt service routine is executed.

Table 5-5 Interrupt Response Time

No.	Item	On-Chip Memory	External Memory	
			2 States	3 States
1	Interrupt priority decision	2*1	2*1	2*1
2	Maximum number of states until end of current instruction	1 to 23	1 to 27	1 to 31*4
3	Saving PC and CCR to stack	4	8	12*4
4	Vector fetch	4	8	12*4
5	Instruction prefetch*2	4	8	12*4
6	Internal processing*3	4	4	4
Total		19 to 41	31 to 57	43 to 73

- Notes:
1. 1 state for internal interrupts.
 2. Prefetch after the interrupt is accepted and prefetch of the first instruction in the interrupt service routine.
 3. Internal processing after the interrupt is accepted and internal processing after prefetch.
 4. The number of states increases if wait states are inserted in external memory access.

5.5 Usage Notes

5.5.1 Contention between Interrupt and Interrupt-Disabling Instruction

When an instruction clears an interrupt enable bit to 0 to disable the interrupt, the interrupt is not disabled until after execution of the instruction is completed. If an interrupt occurs while a BCLR, MOV, or other instruction is being executed to clear its interrupt enable bit to 0, at the instant when execution of the instruction ends the interrupt is still enabled, so its interrupt exception handling is carried out. If a higher-priority interrupt is also requested, however, interrupt exception handling for the higher-priority interrupt is carried out, and the lower-priority interrupt is ignored. This also applies to the clearing of an interrupt flag.

Figure 5-8 shows an example in which an IMIEA bit is cleared to 0 in the ITU.

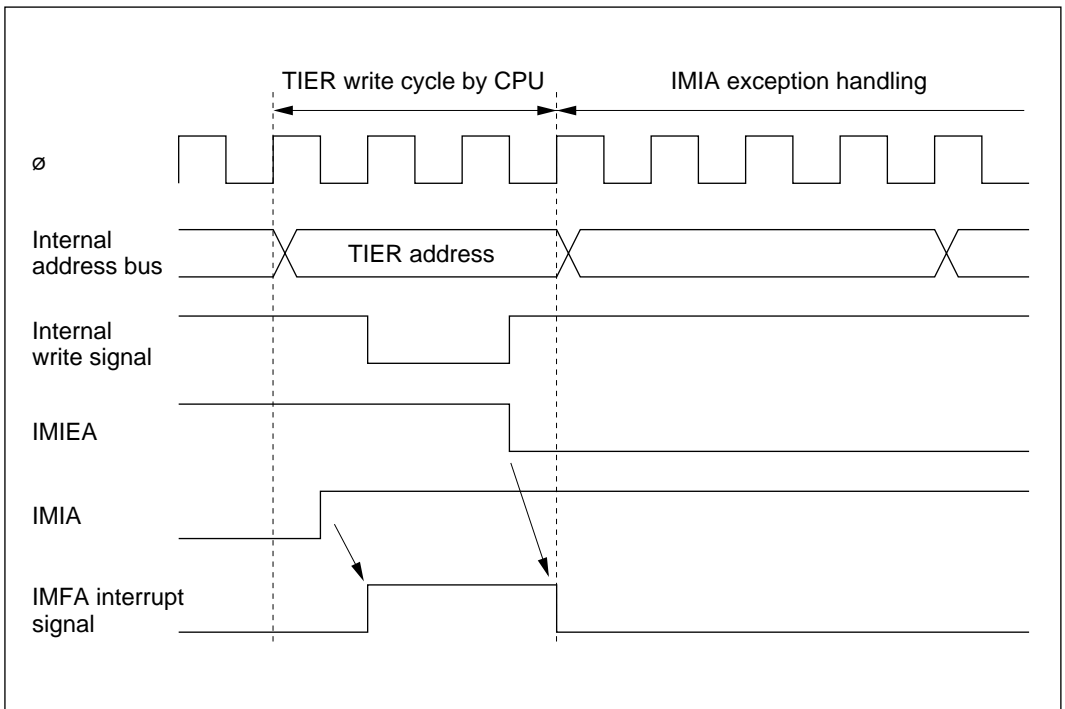

Figure 5-8 Contention between Interrupt and Interrupt-Disabling Instruction

This type of contention will not occur if the interrupt is masked when the interrupt enable bit or flag is cleared to 0.

5.5.2 Instructions that Inhibit Interrupts

The LDC, ANDC, ORC, and XORC instructions inhibit interrupts. When an interrupt occurs, after determining the interrupt priority, the interrupt controller requests a CPU interrupt. If the CPU is currently executing one of these interrupt-inhibiting instructions, however, when the instruction is completed the CPU always continues by executing the next instruction.

5.5.3 Interrupts during EEPMOV Instruction Execution

The EEPMOV.B and EEPMOV.W instructions differ in their reaction to interrupt requests.

When the EEPMOV.B instruction is executing a transfer, no interrupts are accepted until the transfer is completed, not even NMI.

When the EEPMOV.W instruction is executing a transfer, interrupt requests other than NMI are not accepted until the transfer is completed. If NMI is requested, NMI exception handling starts at a transfer cycle boundary. The PC value saved on the stack is the address of the next instruction.

Programs should be coded as follows to allow for NMI interrupts during EEPMOV.W execution:

```
L1:  EEPMOV.W  
      MOV.W R4,R4  
      BNE  L1
```

Section 6 Bus Controller

6.1 Overview

The H8/3004 and H8/3005 have an on-chip bus controller that divides the external address space into eight areas and can assign different bus specifications to each. This enables different types of memory to be connected easily.

A bus arbitration function of the bus controller controls the operation of the DMA controller (DMAC) and refresh controller. The bus controller can also release the bus to an external device.

6.1.1 Features

Features of the bus controller are listed below.

- Independent settings for address areas 0 to 7
 - 128-kbyte areas in 1-Mbyte mode, or 2-Mbyte areas in 16-Mbyte mode.
 - Areas can be designated for two-state or three-state access.
- Four wait modes
 - Programmable wait mode, pin auto-wait mode, and pin wait modes 0 and 1 can be selected.
 - Zero to three wait states can be inserted automatically.

6.1.2 Block Diagram

Figure 6-1 shows a block diagram of the bus controller.

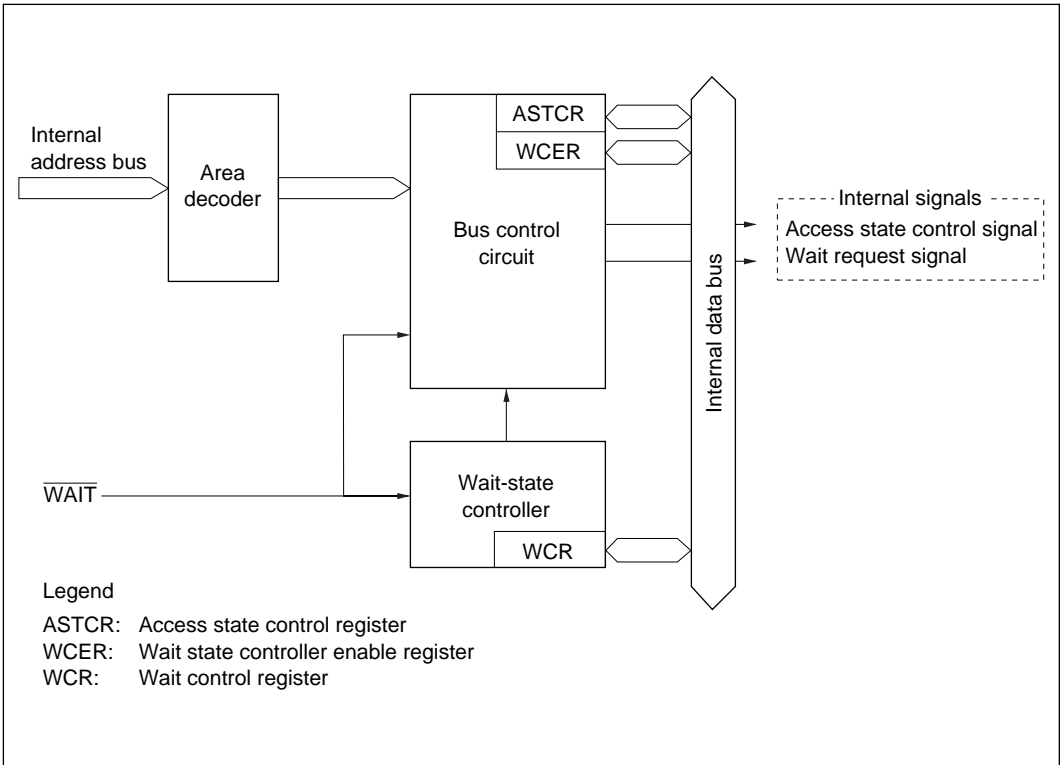

Figure 6-1 Block Diagram of Bus Controller

6.1.3 Input/Output Pins

Table 6-1 summarizes the bus controller's input/output pins.

Table 6-1 Bus Controller Pins

Name	Abbreviation	I/O	Function
Address strobe	\overline{AS}	Output	Strobe signal indicating valid address output on the address bus
Read	\overline{RD}	Output	Strobe signal indicating reading from the external address space
Write	\overline{WR}	Output	Strobe signal indicating writing to the external address space, with valid data on the data bus
Wait	\overline{WAIT}	Input	Wait request signal for access to external three-state-access areas

6.1.4 Register Configuration

Table 6-2 summarizes the bus controller's registers.

Table 6-2 Bus Controller Registers

Address*	Name	Abbreviation	R/W	Initial Value
H'FFED	Access state control register	ASTCR	R/W	H'FF
H'FFEE	Wait control register	WCR	R/W	H'F3
H'FFEF	Wait state controller enable register	WCER	R/W	H'FF

Note: * Lower 16 bits of the address.

6.2 Register Descriptions

6.2.1 Wait Control Register (WCR)

WCR is an 8-bit readable/writable register that selects the wait mode for the wait-state controller (WSC) and specifies the number of wait states.

Bit	7	6	5	4	3	2	1	0
	—	—	—	—	WMS1	WMS0	WC1	WC0
Initial value	1	1	1	1	0	0	1	1
Read/Write	—	—	—	—	R/W	R/W	R/W	R/W

Reserved bits
 These bits are reserved and always read as 1.

Wait mode select 1/0
 These bits select the wait mode.

Wait count 1/0
 These bits select the number of wait states inserted.

WCR is initialized to H'F3 by a reset and in hardware standby mode. It is not initialized in software standby mode.

Bits 7 to 4—Reserved: Read-only bits, always read as 1.

Bits 3 and 2—Wait Mode Select 1 and 0 (WMS1/0): These bits select the wait mode.

Bit 3 WMS1	Bit 2 WMS0	Description
0	0	Programmable wait mode (Initial value)
	1	No wait states inserted by wait-state controller
1	0	Pin wait mode 1
	1	Pin auto-wait mode

Bits 1 and 0—Wait Count 1 and 0 (WC1/0): These bits select the number of wait states inserted in access to external three-state-access areas.

Bit 1 WC1	Bit 0 WC0	Description
0	0	No wait states inserted by wait-state controller
	1	1 state inserted
1	0	2 states inserted
	1	3 states inserted (Initial value)

6.2.2 Access State Control Register (ASTCR)

ASTCR is an 8-bit readable/writable register that selects whether each area is accessed in two states or three states.

Bit	7	6	5	4	3	2	1	0
	AST7	AST6	AST5	AST4	AST3	AST2	AST1	AST0
Initial value	1	1	1	1	1	1	1	1
Read/Write	R/W	R/W	R/W	R/W	R/W	R/W	R/W	R/W

Bits selecting number of states for access to each area

ASTCR is initialized to H'FF by a reset and in hardware standby mode. It is not initialized in software standby mode.

Bits 7 to 0—Area 7 to 0 Access State Control (AST7 to AST0): These bits select whether the corresponding area is accessed in two or three states.

Bits 7 to 0 AST7 to AST0	Description
0	Areas 7 to 0 are accessed in two states
1	Areas 7 to 0 are accessed in three states (Initial value)

ASTCR specifies the number of states in which external areas are accessed. On-chip memory and registers are accessed in a fixed number of states that does not depend on ASTCR settings.

6.2.3 Wait State Controller Enable Register (WCER)

WCER is an 8-bit readable/writable register that enables or disables wait-state control of external three-state-access areas by the wait-state controller.

Bit	7	6	5	4	3	2	1	0
	WCE7	WCE6	WCE5	WCE4	WCE3	WCE2	WCE1	WCE0
Initial value	1	1	1	1	1	1	1	1
Read/Write	R/W	R/W	R/W	R/W	R/W	R/W	R/W	R/W

Wait state controller enable 7 to 0

These bits enable or disable wait-state control

WCER is initialized to H'FF by a reset and in hardware standby mode. It is not initialized in software standby mode.

Bits 7 to 0—Wait-State Controller Enable 7 to 0 (WCE7 to WCE0): These bits enable or disable wait-state control of external three-state-access areas.

Bits 7 to 0

WCE7 to WCE0 Description

0	Wait-state control disabled (pin wait mode 0)	
1	Wait-state control enabled	(Initial value)

The bus specifications for each area can be selected in ASTCR, WCER, and WCR as shown in table 6-3.

Table 6-3 Bus Specifications

ASTCR	WCER	WCR		Bus Specifications		
ASTn	WCEn	WMS1	WMS0	Bus Width	Access States	Wait Mode
0	—	—	—	8	2	Disabled
1	0	—	—	8	3	Pin wait mode 0
		1	0	0	8	3
	1		1	8	3	Disabled
	1		0	8	3	Pin wait mode 1
	1	1	8	3	Pin auto-wait mode	

Note: n = 0 to 7

6.3.2 Bus Control Signal Timing

Three-State-Access Areas: Figure 6-3 shows the timing of bus control signals for a three-state-access area. Wait states can be inserted.

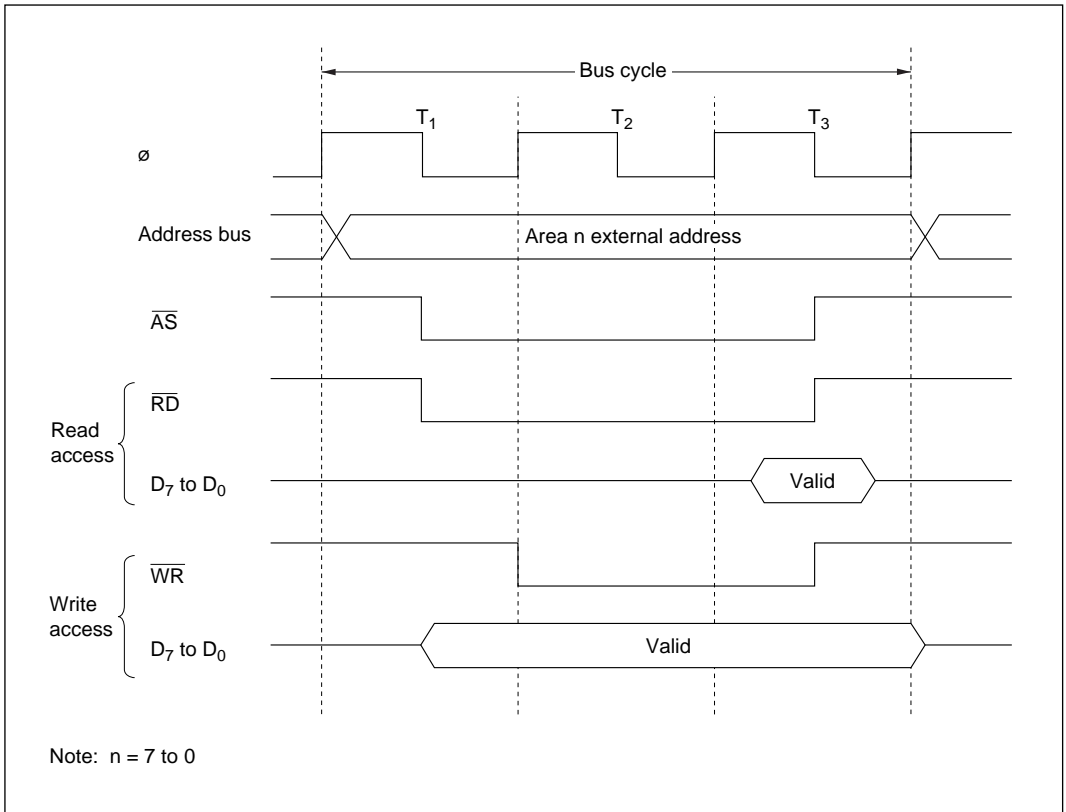

Figure 6-3 Bus Control Signal Timing for Three-State-Access Area

Two-State-Access Areas: Figure 6-4 shows the timing of bus control signals for a two-state-access area. Wait status cannot be inserted.

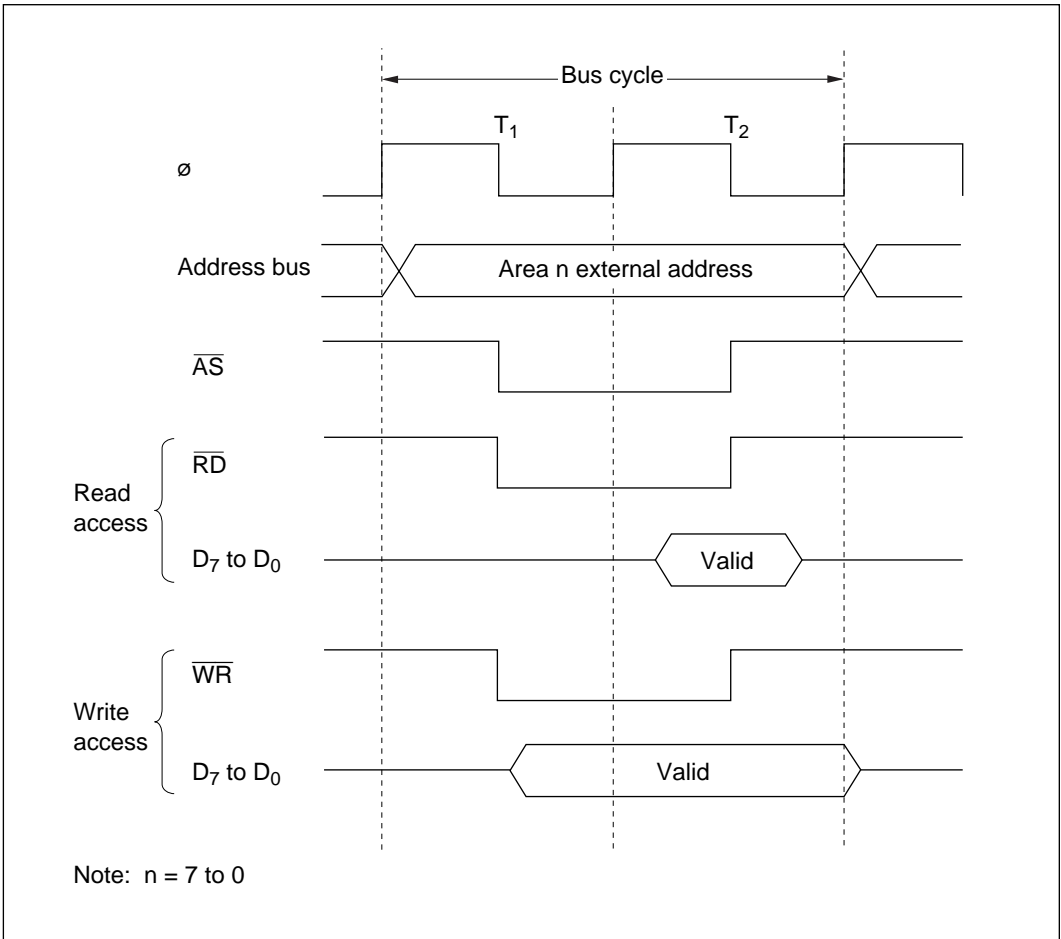

Figure 6-4 Bus Control Signal Timing for Two-State-Access Area

6.3.3 Wait Modes

Four wait modes can be selected for each area as shown in table 6-4.

Table 6-4 Wait Mode Selection

ASTCR	WCER	WCR		WSC Control	Wait Mode
ASTn Bit	WCEn Bit	WMS1 Bit	WMS0 Bit		
0	—	—	—	Disabled	No wait states
1	0	—	0	Disabled	Pin wait mode 0
			1	Enabled	Programmable wait mode
	1	0	1	Enabled	No wait states
			1	Enabled	Pin wait mode 1
			1	Enabled	Pin auto-wait mode

Note: n = 7 to 0

The ASTn and WCEn bits can be set independently for each area. Bits WMS1 and WMS0 apply to all areas. All areas for which WSC control is enabled operate in the same wait mode.

Pin Wait Mode 0: The wait state controller is disabled. Wait states can only be inserted by $\overline{\text{WAIT}}$ pin control. During access to an external three-state-access area, if the $\overline{\text{WAIT}}$ pin is low at the fall of the system clock (ϕ) in the T_2 state, a wait state (T_W) is inserted. If the $\overline{\text{WAIT}}$ pin remains low, wait states continue to be inserted until the $\overline{\text{WAIT}}$ signal goes high. Figure 6-5 shows the timing.

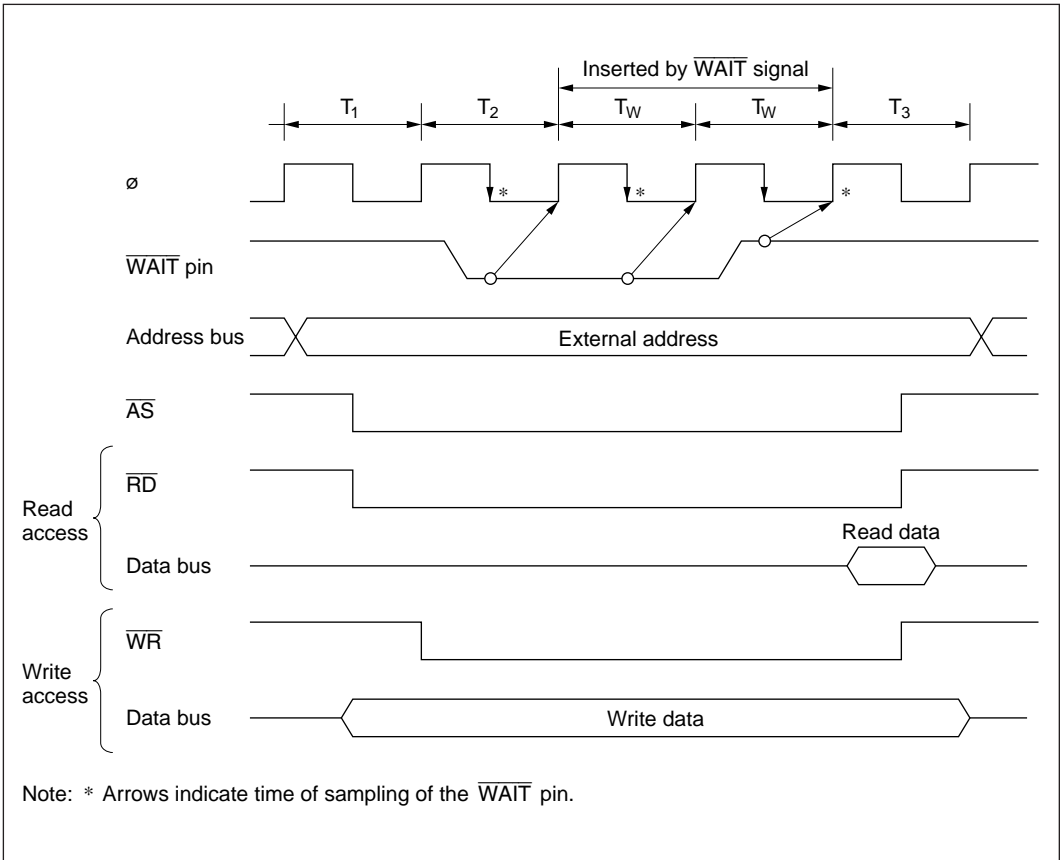

Figure 6-5 Pin Wait Mode 0

Pin Wait Mode 1: In all accesses to external three-state-access areas, the number of wait states (T_W) selected by bits $WC1$ and $WC0$ are inserted. If the \overline{WAIT} pin is low at the fall of the system clock (ϕ) in the last of these wait states, an additional wait state is inserted. If the \overline{WAIT} pin remains low, wait states continue to be inserted until the \overline{WAIT} signal goes high.

Pin wait mode 1 is useful for inserting four or more wait states, or for inserting different numbers of wait states for different external devices.

If the wait count is 0, this mode operates in the same way as pin wait mode 0.

Figure 6-6 shows the timing when the wait count is 1 ($WC1 = 0$, $WC0 = 1$) and one additional wait state is inserted by \overline{WAIT} input.

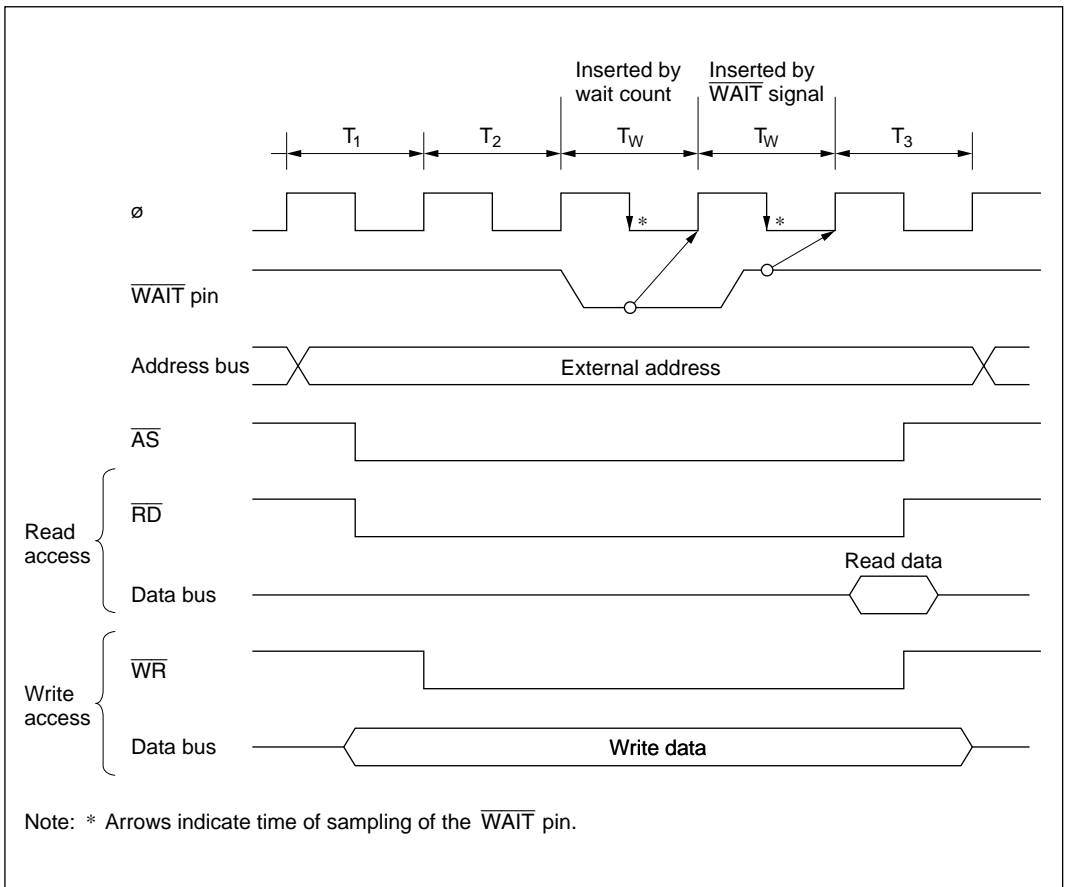

Figure 6-6 Pin Wait Mode 1

Pin Auto-Wait Mode: If the $\overline{\text{WAIT}}$ pin is low, the number of wait states (T_W) selected by bits WC1 and WC0 are inserted.

In pin auto-wait mode, if the $\overline{\text{WAIT}}$ pin is low at the fall of the system clock (ϕ) in the T_2 state, the number of wait states (T_W) selected by bits WC1 and WC0 are inserted. No additional wait states are inserted even if the $\overline{\text{WAIT}}$ pin remains low.

Figure 6-7 shows the timing when the wait count is 1.

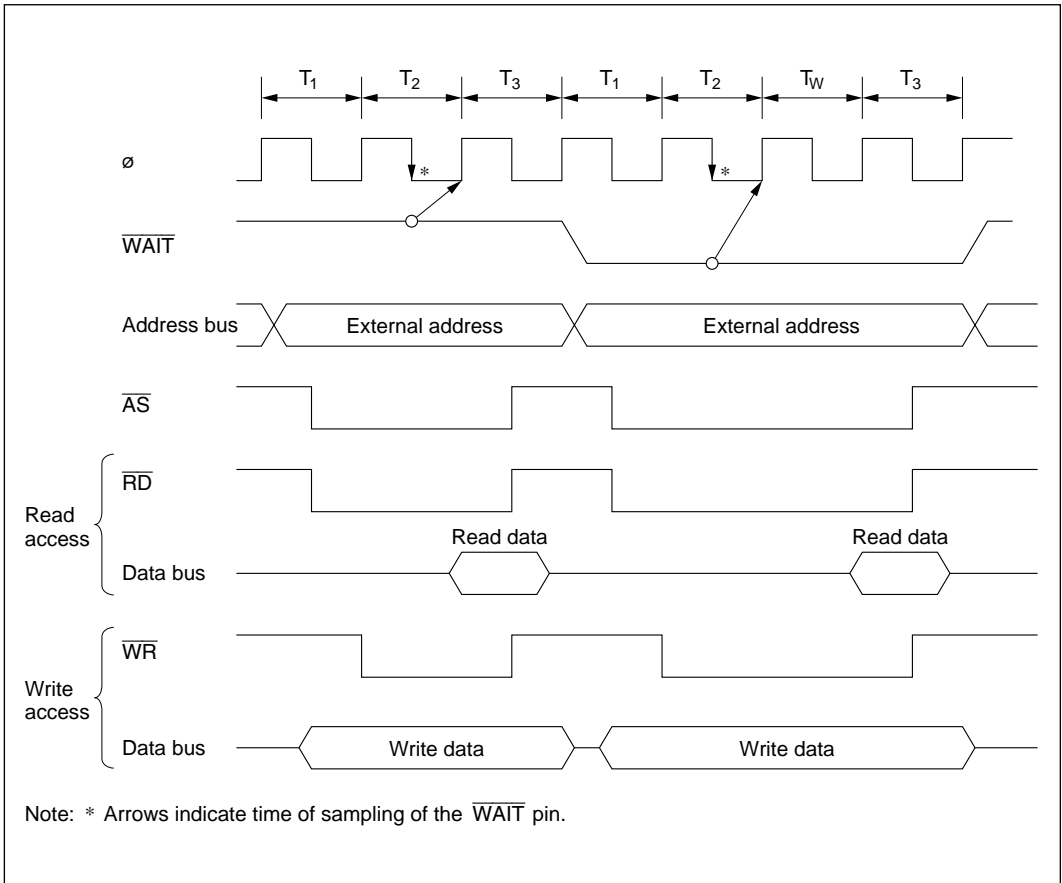

Figure 6-7 Pin Auto-Wait Mode

Programmable Wait Mode: The number of wait states (T_W) selected by bits WC1 and WC0 are inserted in all accesses to external three-state-access areas. Figure 6-8 shows the timing when the wait count is 1 ($WC1 = 0$, $WC0 = 1$).

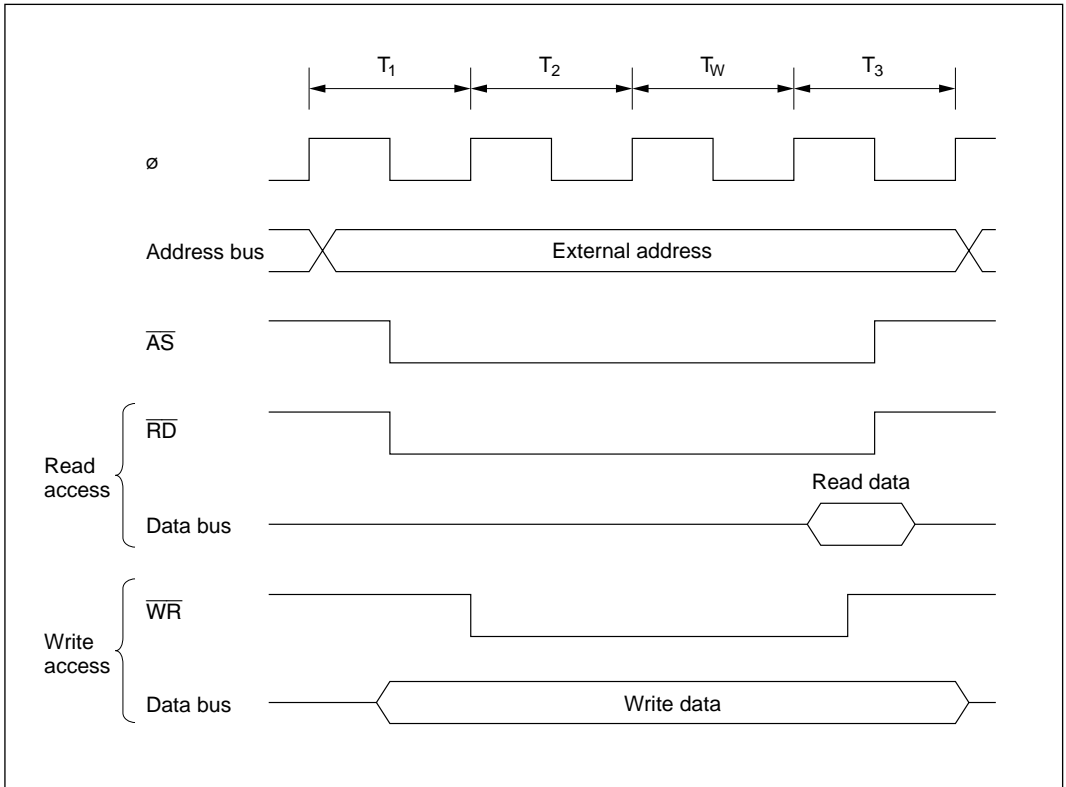

Figure 6-8 Programmable Wait Mode

Example of Wait State Control Settings: A reset initializes ASTCR and WCER to H'FF and WCR to H'F3, selecting programmable wait mode and three wait states for all areas. Software can select other wait modes for individual areas by modifying the ASTCR, WCER, and WCR settings. Figure 6-9 shows an example of wait mode settings.

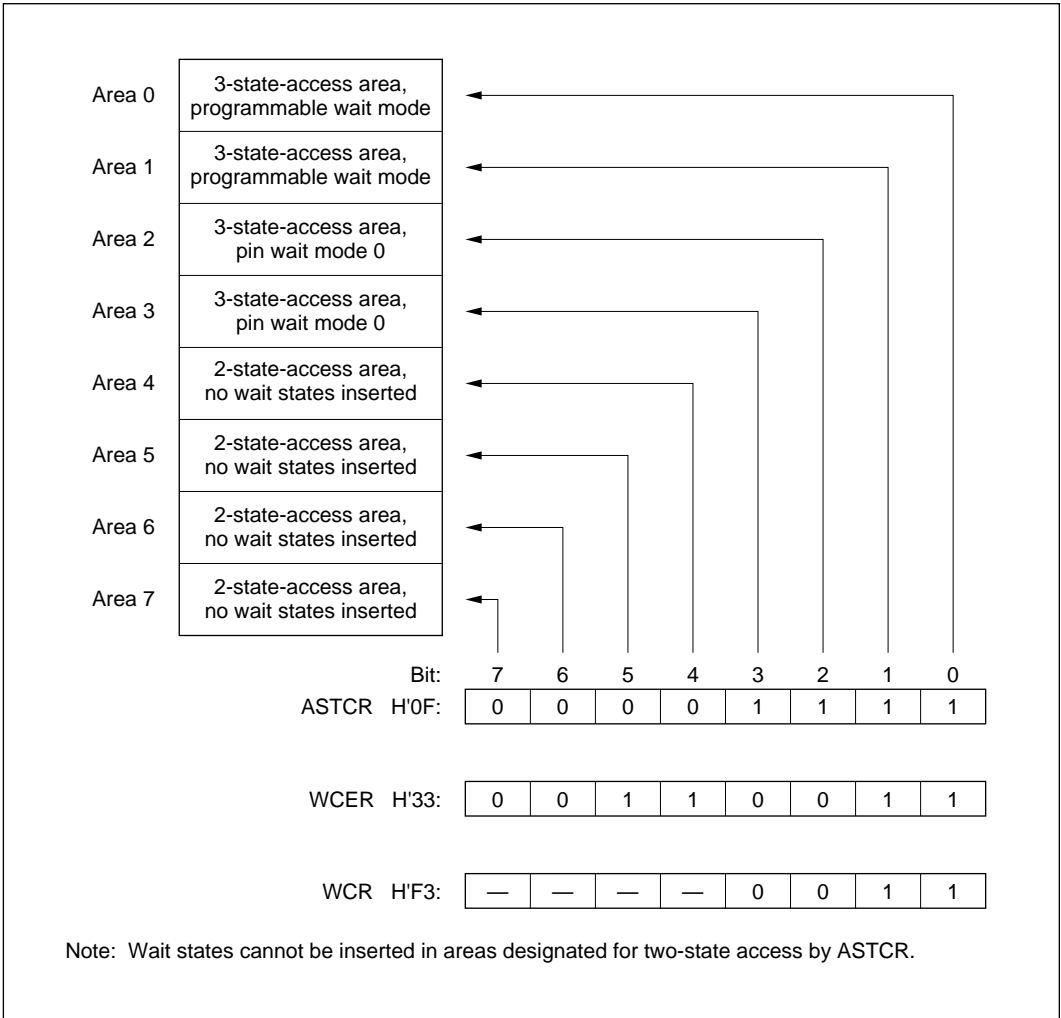

Figure 6-9 Wait Mode Settings (Example)

6.3.4 Interconnections with Memory (Example)

For each area, the bus controller can select two- or three-state access. In three-state-access areas, wait states can be inserted in a variety of modes, simplifying the connection of both high-speed and low-speed devices.

Figure 6-10 shows an example of the memory map.

A 16-kword \times 8-bit EPROM is connected to area 0. This device is accessed in three states.

Two 32-kword \times 8-bit SRAM devices (SRAM1 and SRAM2) are connected to area 1. These devices are accessed in two states.

One 32-kword \times 8-bit SRAM (SRAM3) is connected to area 7. This device is accessed via an 8-bit bus, using three-state access with an additional wait state inserted in pin auto-wait mode.

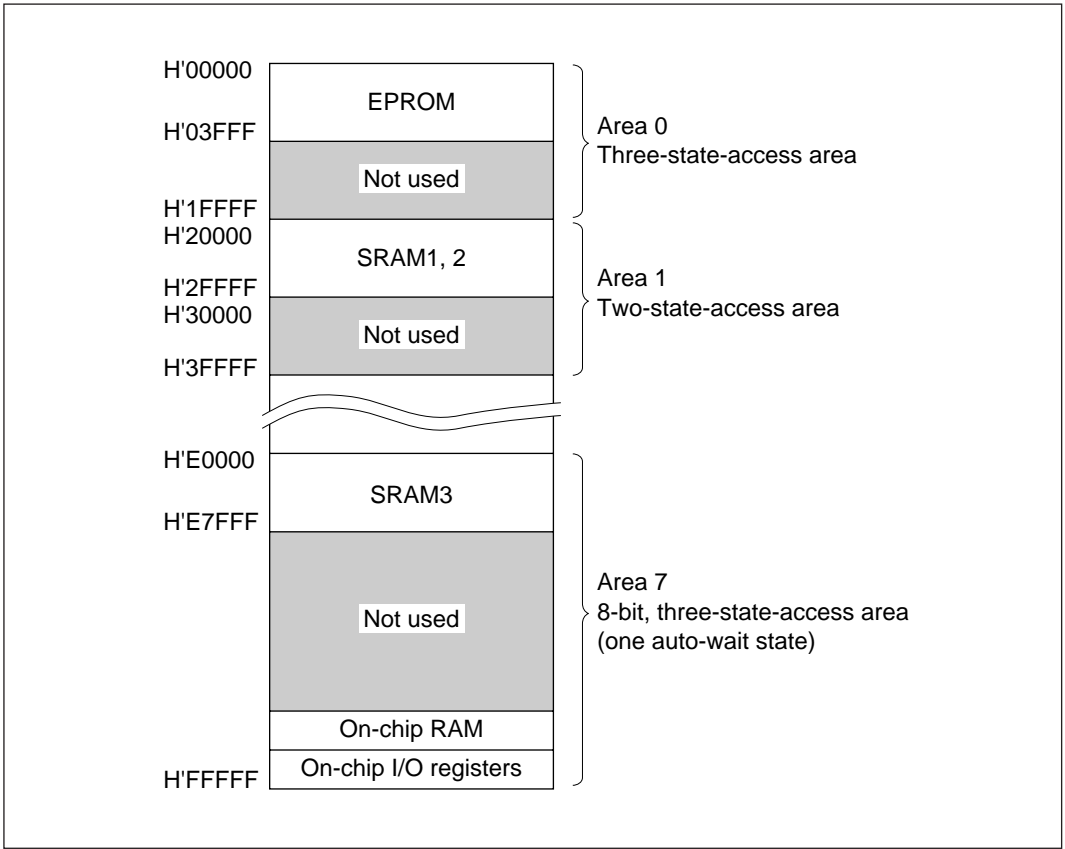

Figure 6-10 Memory Map (Example)

6.4 Usage Notes

6.4.1 Register Write Timing

ASTCR and WCER Write Timing: Data written to ASTCR or WCER takes effect starting from the next bus cycle. Figure 6-11 shows the timing when an instruction fetched from area 0 changes area 0 from three-state access to two-state access.

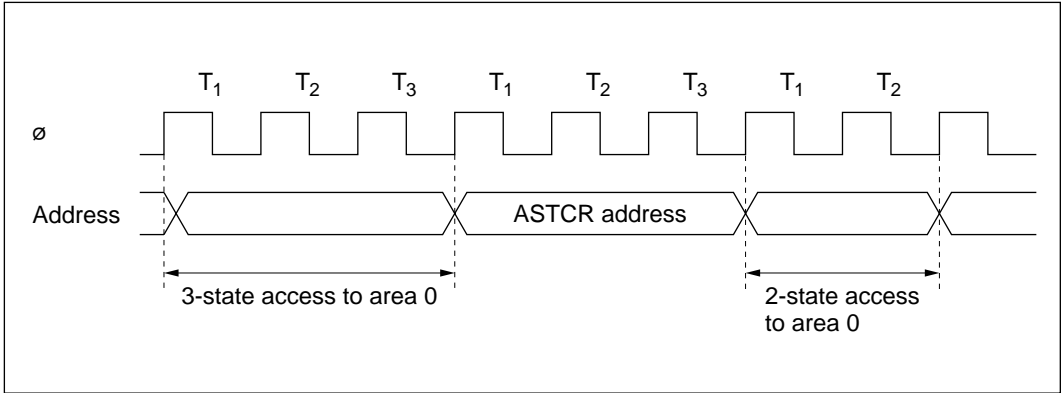

Figure 6-11 ASTCR Write Timing

Section 7 I/O Ports

7.1 Overview

The H8/3004 and H8/3005 have five input/output ports (ports 6, 8, 9, A, and B) and one input port (port 7). Table 7-1 summarizes the port functions. The pins in each port are multiplexed as shown in table 7-1.

Ports 6 and 8 can drive one TTL load and a 90-pF capacitive load. Ports 9, A, and B can drive one TTL load and a 30-pF capacitive load. Ports 6, 8, 9, A, and B can drive a darlington pair. Port B can drive an LED (with 10-mA current sink). Pins P8₂ to P8₀, PA₇ to PA₀, and PB₃ to PB₀ have Schmitt-trigger input circuits.

For block diagrams of the ports see appendix C, I/O Port Block Diagrams.

Table 7-1 Port Functions

Port	Description	Pins	Mode 1	Mode 3
Port 6	• 1-bit I/O port	P6 ₀ / $\overline{\text{WAIT}}$	Bus control signal input/output ($\overline{\text{WAIT}}$) and generic input/output	
Port 7	• 8-bit input port	P7 ₇ to P7 ₀ / AN ₇ to AN ₀	Analog input (AN ₇ to AN ₀) to A/D converter, and 8-bit generic input	
Port 8	• 4-bit I/O port • P8 ₂ to P8 ₀ have Schmitt inputs	P8 ₃ / $\overline{\text{IRQ}}_3$ P8 ₂ / $\overline{\text{IRQ}}_2$ P8 ₁ / $\overline{\text{IRQ}}_1$	$\overline{\text{IRQ}}_3$ to $\overline{\text{IRQ}}_1$ input and generic input DDR = 0 (after reset): generic input DDR = 1: not used	
		P8 ₀ / $\overline{\text{IRQ}}_0$	$\overline{\text{IRQ}}_0$ input and generic input/output	
Port 9	• 3-bit I/O port	P9 ₄ / $\overline{\text{SCK}}/\overline{\text{IRQ}}_4$ P9 ₂ /RxD P9 ₀ /TxD	Input and output (SCK, RxD, TxD) for serial communication interface (SCI), $\overline{\text{IRQ}}_4$ input, and 3-bit generic input/output	
Port A	• 8-bit I/O port • Schmitt input	PA ₇ /TIOCB ₂ /A ₂₀ PA ₆ /TIOCA ₂ /A ₂₁ PA ₅ /TIOCB ₁ /A ₂₂ PA ₄ /TIOCA ₁ /A ₂₃	Input and output (TIOCB ₂ to TIOCA ₁) for 16-bit integrated timer unit (ITU), and generic input/output	Address output (A ₂₃ to A ₂₀)
		PA ₃ /TIOCB ₀ /TCLKD PA ₂ /TIOCA ₀ /TCLKC PA ₁ /TCLKB PA ₀ /TCLKA	Input and output (TIOCB ₀ , TIOCA ₀ , TCLKA to TCLKD) for ITU, and generic input/output	
Port B	• 8-bit I/O port converter, • Can drive LED • PB ₃ to PB ₀ have Schmitt inputs	PB ₇ / $\overline{\text{ADTRG}}$ PB ₆ PB ₅ /TOCXB ₄ PB ₄ /TOCXA ₄ PB ₃ /TIOCB ₄ PB ₂ /TIOCA ₄ PB ₁ /TIOCB ₃ PB ₀ /TIOCA ₃	External trigger input ($\overline{\text{ADTRG}}$) to A/D input and output (TOCXB ₄ , TOCXA ₄ , TIOCB ₄ , TIOCA ₄ , TIOCB ₃ , TIOCA ₃) for ITU, and 8-bit generic input/output	

7.2 Port 6

7.2.1 Overview

Port 6 is a 1-bit input/output port that is also used for input of a bus control signal ($\overline{\text{WAIT}}$).

Figure 7-1 shows the pin configuration of port 6.

The port 6 pin can drive one TTL load and a 90-pF capacitive load. It can also drive a darlington transistor pair.

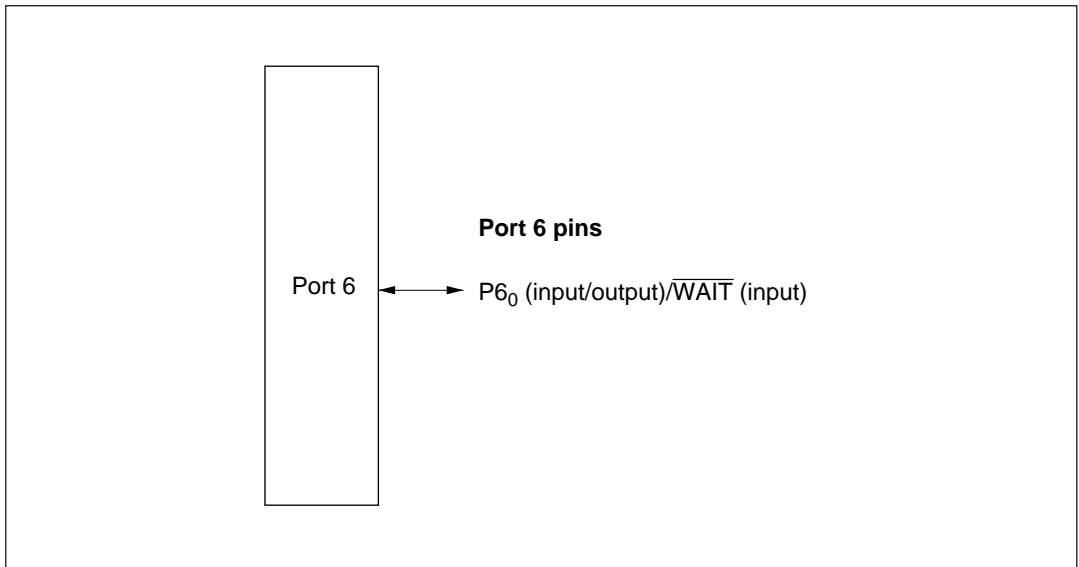

Figure 7-1 Port 6 Pin Configuration

7.2.2 Register Descriptions

Table 7-2 summarizes the registers of port 6.

Table 7-2 Port 6 Registers

Address*	Name	Abbreviation	R/W	Initial Value
H'FFC9	Port 6 data direction register	P6DDR	W	H'80
H'FFCB	Port 6 data register	P6DR	R/W	H'80

Note: * Lower 16 bits of the address.

Port 6 Data Direction Register (P6DDR): P6DDR is an 8-bit write-only register that can select input or output for the port 6 pin.

Bit	7	6	5	4	3	2	1	0
	—	—	—	—	—	—	—	P6 ₀ DDR
Initial value	1	0	0	0	0	0	0	0
Read/Write	—	W	W	W	W	W	W	W

Reserved bit

Port 6 data direction 0
This bit selects input or output for the port 6 pin

The port 6 pin becomes an output pin if the corresponding P6DDR bit is set to 1, and an input pin if this bit is cleared to 0.

Bits 7 to 1 are reserved.

P6DDR is a write-only register. Its value cannot be read. All bits return 1 when read.

P6DDR is initialized to H'80 by a reset and in hardware standby mode. In software standby mode it retains its previous setting. If a P6DDR bit is set to 1, the corresponding pin maintains its output state in software standby mode.

Port 6 Data Register (P6DR): P6DR is an 8-bit readable/writable register that stores data for pin P6₀.

Bit	7	6	5	4	3	2	1	0
	—	—	—	—	—	—	—	P6 ₀
Initial value	1	0	0	0	0	0	0	0
Read/Write	—	R/W	R/W	R/W	R/W	R/W	R/W	R/W

Reserved bit

Port 6 data 0
This bit stores data for P6₀ pin

When a bit in P6DDR is set to 1, if port 6 is read the value of the corresponding P6DR bit is returned directly. Bits 7 to 1 are reserved. Bit 7 cannot be modified and always reads 1. Bits 6, 2, and 1 can be written and read, but cannot be used as ports. If bit 6, 2, or 1 in P6DDR is read while its value is 1, the value of the corresponding bit in P6DR will be read. If bit 6, 2, or 1 in P6DDR is read while its value is 0, it will always read 1.

Bits 5 to 3 can be written and read, but cannot be used as ports. If bit 5 to 3 in P6DDR is read while its value is 1, the value of the corresponding bit in P6DR will be read. If bit 5 to 3 in P6DDR is read while its value is 0, it will be undefined.

P6DR is initialized to H'80 by a reset and in hardware standby mode. In software standby mode it retains its previous setting.

7.2.3 Pin Functions

The port 6 pin also functions as the $\overline{\text{WAIT}}$ input pin. Table 7-3 shows the functions of the port 6 pin.

Table 7-3 Port 6 Pin Functions

Pin	Pin Functions and Selection Method			
P6 ₀ / $\overline{\text{WAIT}}$	Bits WCE7 to WCE0 in WCER, bit WMS1 in WCR, and bit P6 ₀ DDR select the pin function as follows.			
	WCER	All 1s		Not all 1s
	WMS1	0	1	—
	P6 ₀ DDR	0	1	0*
	Pin function	P6 ₀ input	P6 ₀ output	$\overline{\text{WAIT}}$ input

Note: * Do not set bit P6₀DDR to 1.

7.3 Port 7

7.3.1 Overview

Port 7 is an 8-bit input port that is also used for analog input to the A/D converter. The pin functions are the same in all operating modes. Figure 7-2 shows the pin configuration of port 7.

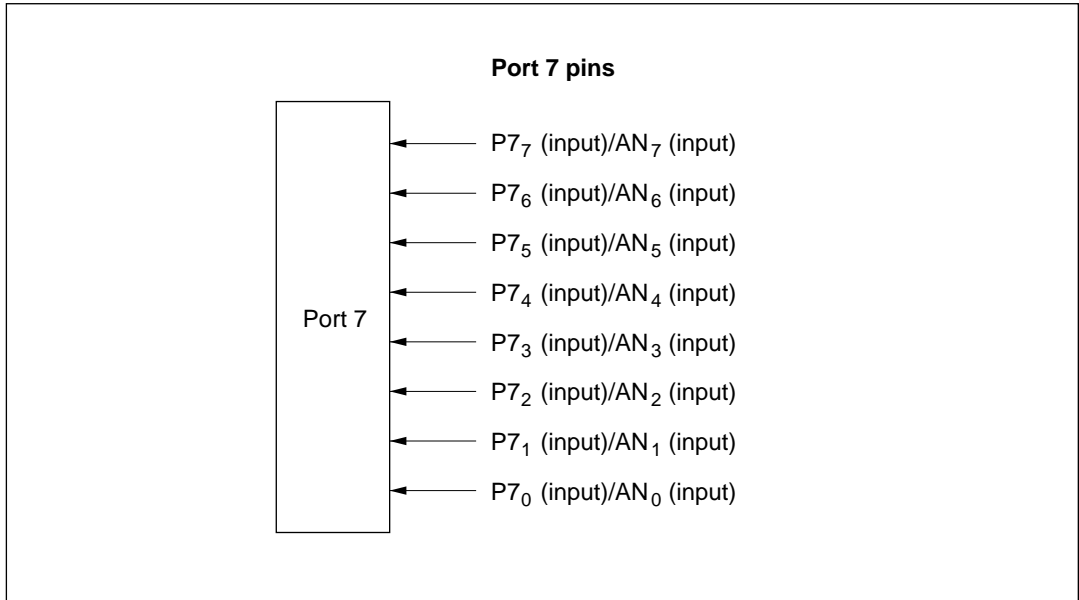

Figure 7-2 Port 7 Pin Configuration

7.3.2 Register Description

Table 7-4 summarizes the port 7 register. Port 7 is an input-only port, so it has no data direction register.

Table 7-4 Port 7 Data Register

Address*	Name	Abbreviation	R/W	Initial Value
H'FFCE	Port 7 data register	P7DR	R	Undetermined

Note: * Lower 16 bits of the address.

Port 7 Data Register (P7DR)

Bit	7	6	5	4	3	2	1	0
	P7 ₇	P7 ₆	P7 ₅	P7 ₄	P7 ₃	P7 ₂	P7 ₁	P7 ₀
Initial value	—*	—*	—*	—*	—*	—*	—*	—*
Read/Write	R	R	R	R	R	R	R	R

Note: * Determined by pins P7₇ to P7₀.

When port 7 is read, the pin levels are always read.

7.4 Port 8

7.4.1 Overview

Port 8 is a 4-bit input/output port that is also used for $\overline{\text{IRQ}}_3$ to $\overline{\text{IRQ}}_0$ input. Port 8 pin functions are the same in both operating modes. Figure 7-3 shows the pin configuration of port 8.

Pins in port 8 can drive one TTL load and a 90-pF capacitive load. They can also drive a darlington transistor pair. Pins P8₂ to P8₀ have Schmitt-trigger inputs.

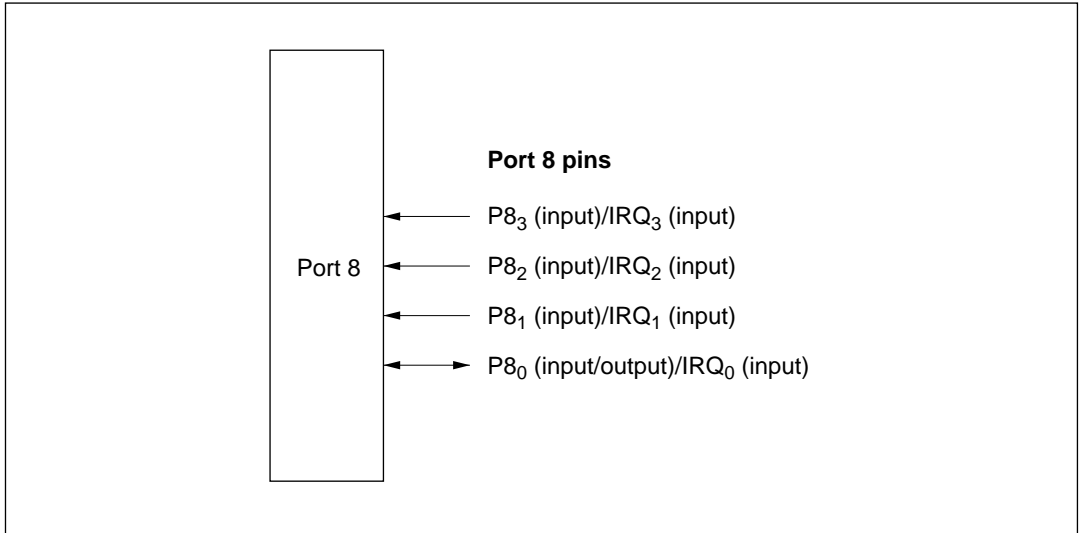

Figure 7-3 Port 8 Pin Configuration

7.4.2 Register Descriptions

Table 7-5 summarizes the registers of port 8.

Table 7-5 Port 8 Registers

Address*	Name	Abbreviation	R/W	Initial Value
H'FFCD	Port 8 data direction register	P8DDR	W	H'E0
H'FFCF	Port 8 data register	P8DR	R/W	H'E0

Note: * Lower 16 bits of the address.

Port 8 Data Direction Register (P8DDR): P8DDR is an 8-bit write-only register that can select input or output for each pin in port 8.

Bit	7	6	5	4	3	2	1	0
	—	—	—	—	P8 ₃ DDR	P8 ₂ DDR	P8 ₁ DDR	P8 ₀ DDR
Initial value	1	1	1	0	0	0	0	0
Read/Write	—	—	—	W	W	W	W	W

Reserved bits

Port 8 data direction 3 to 0
These bits select input or output for port 8 pins

Pins P8₃ to P8₁ function as input pins. Do not set P8₃DDR to P8₁DDR to 1. Pin P8₀ functions as an output pin when P8₀DDR is set to 1, and as input pin when P8₀DDR is cleared to 0.

Port 8 is a generic input/output port. A pin port 8 becomes an output pin if the corresponding P8DDR bit is set to 1, and an input pin if this bit is cleared to 0.

P8DDR is a write-only register. Its value cannot be read. All bits return 1 when read.

P8DDR is initialized to H'E0 by a reset and in hardware standby mode. In software standby mode it retains its previous setting. If a P8DDR bit is set to 1, the corresponding pin maintains its output state in software standby mode.

Port 8 Data Register (P8DR): P8DR is an 8-bit readable/writable register that stores data for pins P8₃ to P8₀.

Bit	7	6	5	4	3	2	1	0
	—	—	—	—	P8 ₃	P8 ₂	P8 ₁	P8 ₀
Initial value	1	1	1	0	0	0	0	0
Read/Write	—	—	—	R/W	R/W	R/W	R/W	R/W

Reserved bits
Port 8 data 3 to 0
These bits store data for port 8 pins

When a bit in P8DDR is set to 1, if port 8 is read the value of the corresponding P8DR bit is returned directly. When a bit in P8DDR is cleared to 0, if port 8 is read the corresponding pin level is read.

Bits 7 to 4 are reserved. Bits 7 to 5 cannot be modified and always read 1. Bit 4 can be written and read, but it cannot be used for port input or output. If bit 4 of P8DDR is read while its value is 1, bit 4 of P8DR is read directly. If bit 4 of P8DDR is read while its value is 0, it always reads 1.

P8DR is initialized to H'E0 by a reset and in hardware standby mode. In software standby mode it retains its previous setting.

7.4.3 Pin Functions

The port 8 pins are also used for $\overline{\text{IRQ}}_3$ to $\overline{\text{IRQ}}_0$. Table 7-6 describes the selection of pin functions.

Table 7-6 Port 8 Pin Functions

Pin	Pin Functions and Selection Method		
$\text{P8}_3/\overline{\text{IRQ}}_3$	Bit $\text{P8}_3\text{DDR}$ selects the pin function as follows		
	$\text{P8}_3\text{DDR}$	0	1
	Pin function	P8_3 input	Illegal setting
$\overline{\text{IRQ}}_3$ input			
$\text{P8}_2/\overline{\text{IRQ}}_2$	Bit $\text{P8}_2\text{DDR}$ selects the pin function as follows		
	$\text{P8}_2\text{DDR}$	0	1
	Pin function	P8_2 input	Illegal setting
$\overline{\text{IRQ}}_2$ input			
$\text{P8}_1/\overline{\text{IRQ}}_1$	Bit $\text{P8}_1\text{DDR}$ selects the pin function as follows		
	$\text{P8}_1\text{DDR}$	0	1
	Pin function	P8_1 input	Illegal setting
$\overline{\text{IRQ}}_1$ input			
$\text{P8}_0/\overline{\text{IRQ}}_0$	Bit $\text{P8}_0\text{DDR}$ selects the pin function as follows		
	$\text{P8}_0\text{DDR}$	0	1
	Pin function	P8_0 input	P8_0 output
$\overline{\text{IRQ}}_0$ input			

7.5 Port 9

7.5.1 Overview

Port 9 is a 3-bit input/output port that is also used for input and output (TxD, RxD, SCK) by serial communication interface (SCI), and for $\overline{\text{IRQ}}_4$ input. Port 9 has the same set of pin functions in all operating modes. Figure 7-4 shows the pin configuration of port 9.

Pins in port 9 can drive one TTL load and a 30-pF capacitive load. They can also drive a darlington transistor pair.

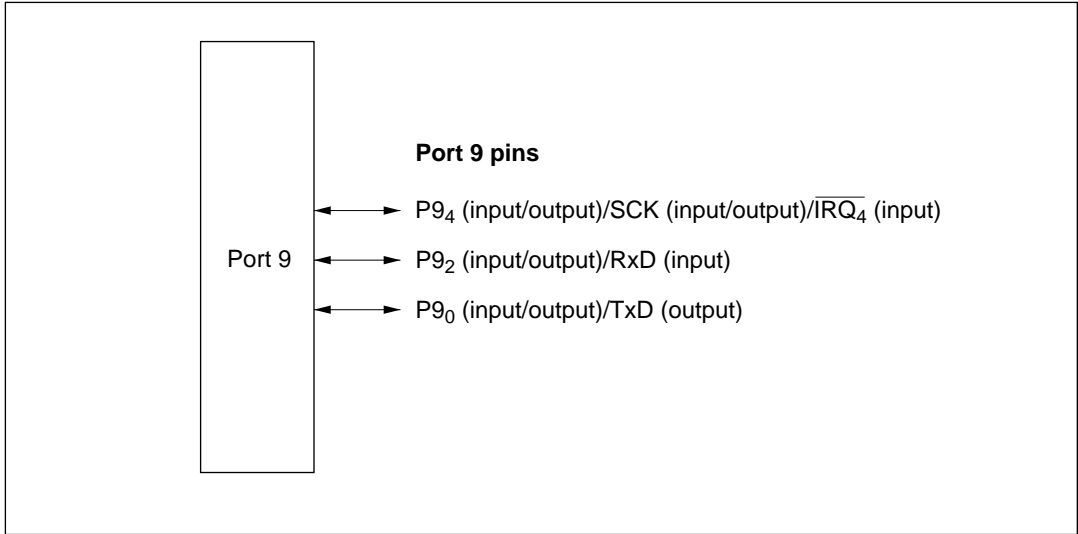

Figure 7-4 Port 9 Pin Configuration

7.5.2 Register Descriptions

Table 7-7 summarizes the registers of port 9.

Table 7-7 Port 9 Registers

Address*	Name	Abbreviation	R/W	Initial Value
H'FFD0	Port 9 data direction register	P9DDR	W	H'C0
H'FFD2	Port 9 data register	P9DR	R/W	H'C0

Note: * Lower 16 bits of the address.

Port 9 Data Direction Register (P9DDR): P9DDR is an 8-bit write-only register that can select input or output for each pin in port 9.

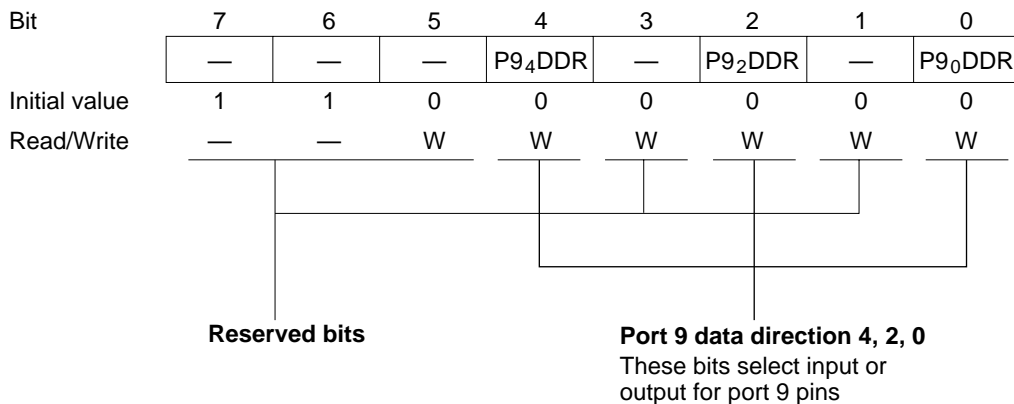

A pin in port 9 becomes an output pin if the corresponding P9DDR bit is set to 1, and an input pin if this bit is cleared to 0.

P9DDR is a write-only register. Its value cannot be read. All bits return 1 when read.

P9DDR is initialized to H'CO by a reset and in hardware standby mode. In software standby mode it retains its previous setting. If a P9DDR bit is set to 1, the corresponding pin maintains its output state in software standby mode.

Port 9 Data Register (P9DR): P9DR is an 8-bit readable/writable register that stores data for pins P9₄, P9₂, and P9₀.

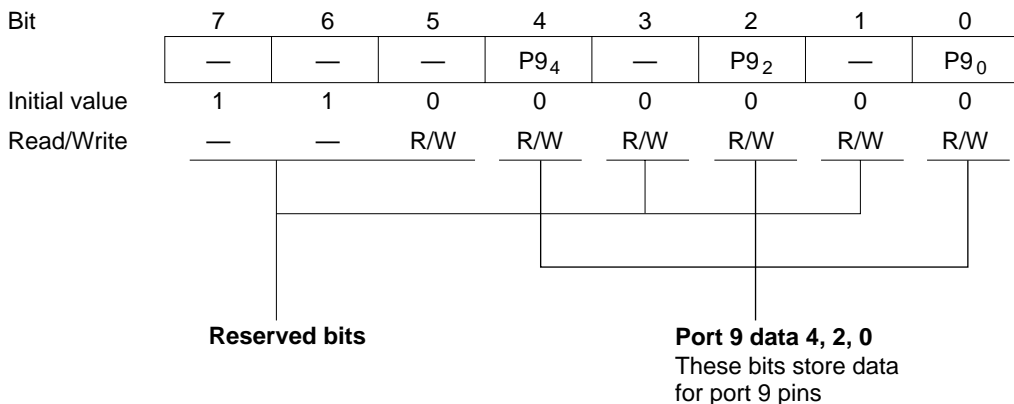

When a bit in P9DDR is set to 1, if port 9 is read the value of the corresponding P9DR bit is returned directly. When a bit in P9DDR is cleared to 0, if port 9 is read the corresponding pin level is read.

Bits 7 to 5, 3 and 1 are reserved. Bits 7 and 6 cannot be modified and always read 1. Bits 5, 3, and 1 can be written and read, but they cannot be used for port input or output. If bit 5, 3 or 1 in P9DDR is read while its value is 1, the corresponding bit in P9DR is read directly. If bit 5, 3, or 1 in P9DDR is read while its value is 0, it always read 1.

P9DR is initialized to H'C0 by a reset and in hardware standby mode. In software standby mode it retains its previous setting.

7.5.3 Pin Functions

The port 9 pins are also used for SCI input and output (TxD, RxD, SCK), and for \overline{IRQ}_4 input. Table 7-8 describes the selection of pin functions.

Table 7-8 Port 9 Pin Functions

Pin	Pin Functions and Selection Method				
P9 ₄ /SCK/ \overline{IRQ}_4	Bit C/ \overline{A} in SMR of SCI, bits CKE0 and CKE1 in SCR of SCI, and bit P9 ₄ DDR select the pin function as follows				
	CKE1		0		1
	C/ \overline{A}		0	1	—
	CKE0		0	1	—
	P9 ₄ DDR		0	1	—
	Pin function		P9 ₄ input	P9 ₄ output	SCK output
			\overline{IRQ}_4 input		
P9 ₂ /RxD	Bit RE in SCR of SCI and bit P9 ₂ DDR select the pin function as follows				
	RE		0		1
	P9 ₂ DDR		0	1	—
	Pin function		P9 ₂ input	P9 ₂ output	RxD input
P9 ₀ /TxD	Bit TE in SCR of SCI and bit P9 ₀ DDR select the pin function as follows				
	TE		0		1
	P9 ₀ DDR		0	1	—
	Pin function		P9 ₀ input	P9 ₀ output	TxD output

7.6 Port A

7.6.1 Overview

Port A is an 8-bit input/output port that is also used for the address bus (A_{23} to A_{20}) from input and output (TIOCB₂, TIOCA₂, TIOCB₁, TIOCA₁, TIOCB₀, TIOCA₀, TCLKD, TCLKC, TCLKB, TCLKA) by the 16-bit integrated timer unit (ITU), Figure 7-5 shows the pin configuration of port A.

Pins in port A can drive one TTL load and a 30-pF capacitive load. They can also drive a darlington transistor pair. Port A has Schmitt-trigger inputs.

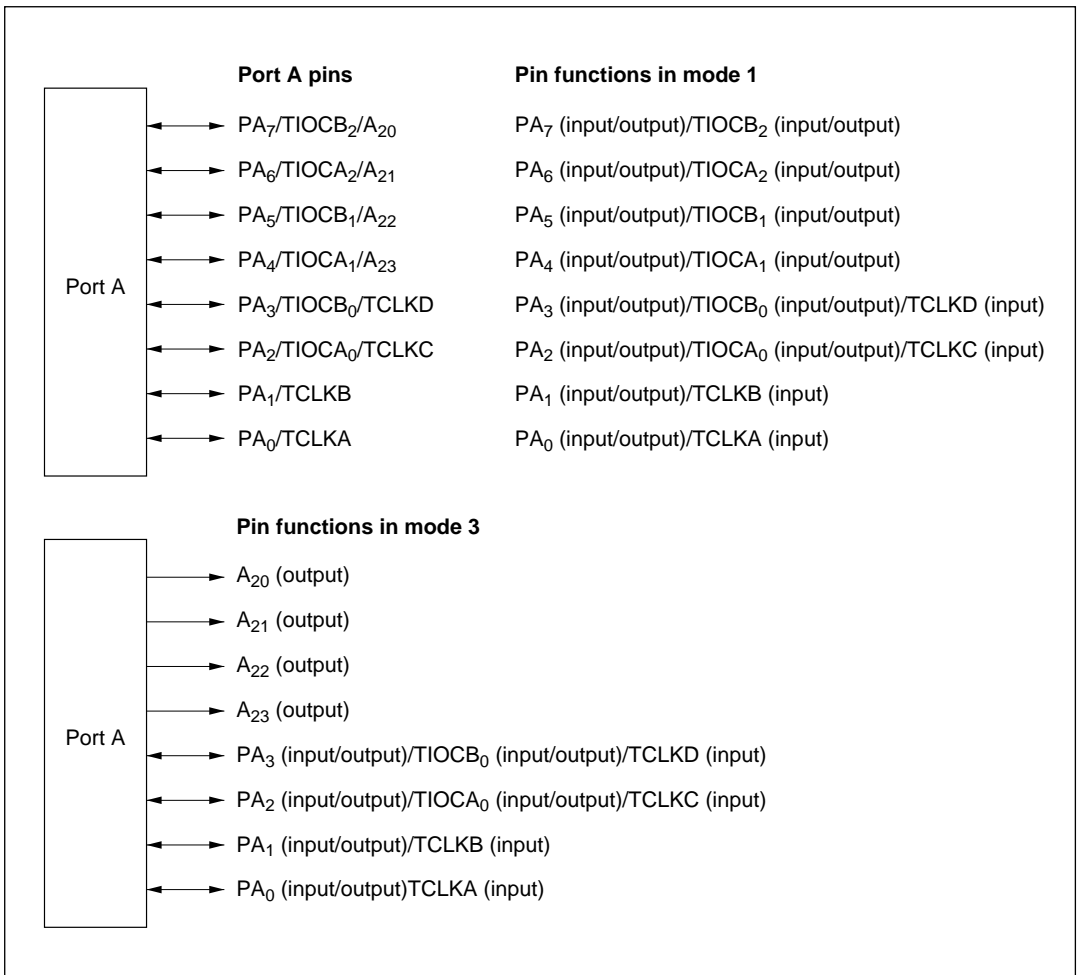

Figure 7-5 Port A Pin Configuration

7.6.2 Register Descriptions

Table 7-9 summarizes the registers of port A.

Table 7-9 Port A Registers

Address*	Name	Abbreviation	R/W	Initial Value
H'FFD1	Port A data direction register	PADDR	W	H'00
H'FFD3	Port A data register	PADR	R/W	H'00

Note: * Lower 16 bits of the address.

Port A Data Direction Register (PADDR): PADDR is an 8-bit write-only register that can select input or output for each pin in port A.

Bit	7	6	5	4	3	2	1	0
	PA ₇ DDR	PA ₆ DDR	PA ₅ DDR	PA ₄ DDR	PA ₃ DDR	PA ₂ DDR	PA ₁ DDR	PA ₀ DDR
Mode 1								
Initial value	0	0	0	0	0	0	0	0
Read/Write	W	W	W	W	W	W	W	W
Mode 3								
Initial value	1	0	0	0	0	0	0	0
Read/Write	—	W	W	W	W	W	W	W

Port A data direction 7 to 0

These bits select input or output for port A pins

A pin in port A becomes an output pin if the corresponding PADDR bit is set to 1, and an input pin if this bit is cleared to 0.

PADDR is a write-only register. Its value cannot be read. All bits return 1 when read.

PADDR is initialized to H'00 in mode 1 or H'80 in mode 3 by a reset and in hardware standby mode. In software standby mode it retains its previous setting. If a PADDR bit is set to 1, the corresponding pin maintains its output state in software standby mode.

Port A Data Register (PADR): PADR is an 8-bit readable/writable register that stores data for pins PA₇ to PA₀.

Bit	7	6	5	4	3	2	1	0
	PA ₇	PA ₆	PA ₅	PA ₄	PA ₃	PA ₂	PA ₁	PA ₀
Initial value	0	0	0	0	0	0	0	0
Read/Write	R/W	R/W	R/W	R/W	R/W	R/W	R/W	R/W

Port A data 7 to 0

These bits store data for port A pins

When a bit in PADDR is set to 1, if port A is read the value of the corresponding PADR bit is returned directly. When a bit in PADDR is cleared to 0, if port A is read the corresponding pin level is read.

PADR is initialized to H'00 by a reset and in hardware standby mode. In software standby mode it retains its previous setting.

7.6.3 Pin Functions

The port A pins are also used for ITU input/output (TIOCB₂ to TIOCB₀, TIOCA₂ to TIOCA₀), input (TCLKD, TCLKC, TCLKB, TCLKA), and the address bus (A₂₃ to A₂₀). Table 7-10 describes the selection of pin functions.

Table 7-10 Port A Pin Functions

Pin	Pin Functions and Selection Method
-----	------------------------------------

PA ₇ /TIOCB ₂ / A ₂₀	Mode settings and ITU channel 2 settings (bit PWM2 in TMDR and bits IOB2 to IOB0 in TIOR2) and bit PA ₇ DDR in PADDR select the pin function as follows
--	--

Mode	1			3
ITU channel 2 settings	(1) in table below		(2) in table below	—
PA ₇ DDR	—		0 1	—
Pin function	TIOCB ₂ output		PA ₇ input	A ₂₀ output
			PA ₇ output	
			TIOCB ₂ input*	

Note: * TIOCB₂ input when IOB2 = 1 and PWM2 = 0.

ITU channel 2 settings	(2)		(1)	(2)	
IOB2	0			1	
IOB1	0	0	1	—	
IOB0	0	1	—	—	

Table 7-10 Port A Pin Functions (cont)

Pin Pin Functions and Selection Method

PA₆/TIOCA₂/
A₂₁ Mode settings and ITU channel 2 settings (bit PWM2 in TMDR and bits IOA2 to IOA0 in TIOR2) and bit PA₆DDR in PADDR select the pin function as follows

Mode	1			3
ITU channel 2 settings	(1) in table below		(2) in table below	—
PA ₆ DDR	—		0 1	—
Pin function	TIOCA ₂ output		PA ₆ input	A ₂₁ output
			PA ₆ output	
			TIOCA ₂ input*	

Note: * TIOCA₂ input when IOA2 = 1.

ITU channel 2 settings	(2)	(1)		(2)	(1)
PWM2	0				1
IOA2	0		1	—	—
IOA1	0	0	1	—	—
IOA0	0	1	—	—	—

Table 7-10 Port A Pin Functions (cont)

Pin Pin Functions and Selection Method

PA₅/TIOCB₁/ A₂₂ Mode settings and ITU channel 1 settings (bit PWM1 in TMDR and bits IOB2 to IOB0 in TIOR1) and bit PA₅DDR in PADDR select the pin function as follows

Mode	1			3
ITU channel 1 settings	(1) in table below		(2) in table below	—
PA ₅ DDR	—		0 1	—
Pin function	TIOCB ₁ output		PA ₅ input	A ₂₂ output
			PA ₅ output	
			TIOCB ₁ input*	

Note: * TIOCB₁ input when IOB2 = 1 and PWM1 = 0.

ITU channel 1 settings	(2)		(1)	(2)	
IOB2	0			1	
IOB1	0	0	1	—	
IOB0	0	1	—	—	

Table 7-10 Port A Pin Functions (cont)

Pin Pin Functions and Selection Method

PA₄/TIOCA₁/A₂₃ Mode settings and ITU channel 1 settings (bit PWM1 in TMDR and bits IOA2 to IOA0 in TIOR1) and bit PA₄DDR in PADDR select the pin function as follows

Mode	1			3
ITU channel 1 settings	(1) in table below		(2) in table below	—
PA ₄ DDR	—		0 1	—
Pin function	TIOCA ₁ output		PA ₄ input PA ₄ output	A ₂₃ output
			TIOCA ₁ input*	

Note: * TIOCA₁ input when IOA2 = 1.

ITU channel 1 settings	(2)	(1)		(2)	(1)
PWM1	0				1
IOA2	0		1		—
IOA1	0	0	1	—	—
IOA0	0	1	—	—	—

Table 7-10 Port A Pin Functions (cont)

Pin Pin Functions and Selection Method

PA₃/TIOCB₀/ ITU channel 0 settings (bit PWM0 in TMDR and bits IOB2 to IOB0 in TIOR0), bits
 TCLKD TPSC2 to TPSC0 in TCR4 to TCR0 and bit PA₃DDR in PADDR select the pin
 function as follows

ITU channel 0 settings	(1) in table below	(2) in table below	
PA ₃ DDR	—	0	1
Pin function	TIOCB ₀ output	PA ₃ input	PA ₃ output
		TIOCB ₀ input*1	
	TCLKD input*2		

- Notes: 1. TIOCB₀ input when IOB2 = 1 and PWM0 = 0.
 2. TCLKD input when TPSC2 = TPSC1 = TPSC0 = 1 in any of TCR4 to TCR0.

ITU channel 0 settings	(2)	(1)		(2)
IOB2	0			1
IOB1	0	0	1	—
IOB0	0	1	—	—

Table 7-10 Port A Pin Functions (cont)

Pin Pin Functions and Selection Method

PA₂/TIOCA₀/
TCLKC ITU channel 0 settings (bit PWM0 in TMDR and bits IOA2 to IOA0 in TIOR0), bits TPSC2 to TPSC0 in TCR4 to TCR0 and bit PA₂DDR in PADDR select the pin function as follows

ITU channel 0 settings	(1) in table below	(2) in table below	
PA ₂ DDR	—	0	1
Pin function	TIOCA ₀ output	PA ₂ input	PA ₂ output
		TIOCA ₀ input*1	
	TCLKC input*2		

- Notes: 1. TIOCA₀ input when IOA2 = 1.
2. TCLKC input when TPSC2 = TPSC1 = 1 and TPSC0 = 0 in any of TCR4 to TCR0.

ITU channel 0 settings	(2)	(1)		(2)	(1)
PWM0	0			1	
IOA2	0			1	—
IOA1	0	0	1	—	—
IOA0	0	1	—	—	—

Table 7-10 Port A Pin Functions (cont)**Pin Pin Functions and Selection Method**

PA₁/TCLKB Bit PA₁DDR in PADDR select the pin function as follows

PA ₁ DDR	0	1
Pin function	PA ₁ input	PA ₁ output
	TCLKB input*	

Note: * TCLKB input when MDF = 1 in TMDR, or when TPSC2 = 1, TPSC1 = 0, and TPSC0 = 1 in any of TCR4 to TCR0.

PA₀/TCLKA Bit PA₀DDR in PADDR select the pin function as follows

PA ₀ DDR	0	1
Pin function	PA ₀ input	PA ₀ output
	TCLKA input*	

Note: * TCLKA input when MDF = 1 in TMDR, or when TPSC2 = 1, TPSC1 = 0 and TPSC0 = 0 in any of TCR4 to TCR0.

7.7 Port B

7.7.1 Overview

Port B is an 8-bit input/output port that is also used for ITU input/output (TIOCB₄, TIOCB₃, TIOCA₄, TIOCA₃) and ITU output (TOCXB₄, TOCXA₄), and $\overline{\text{ADTRG}}$ input to the A/D converter. Port B has the same set of pin functions in all operating modes. Figure 7-6 shows the pin configuration of port B.

Pins in port B can drive one TTL load and a 30-pF capacitive load. They can also drive a darlington transistor pair. Pins PB₃ to PB₀ have Schmitt-trigger inputs.

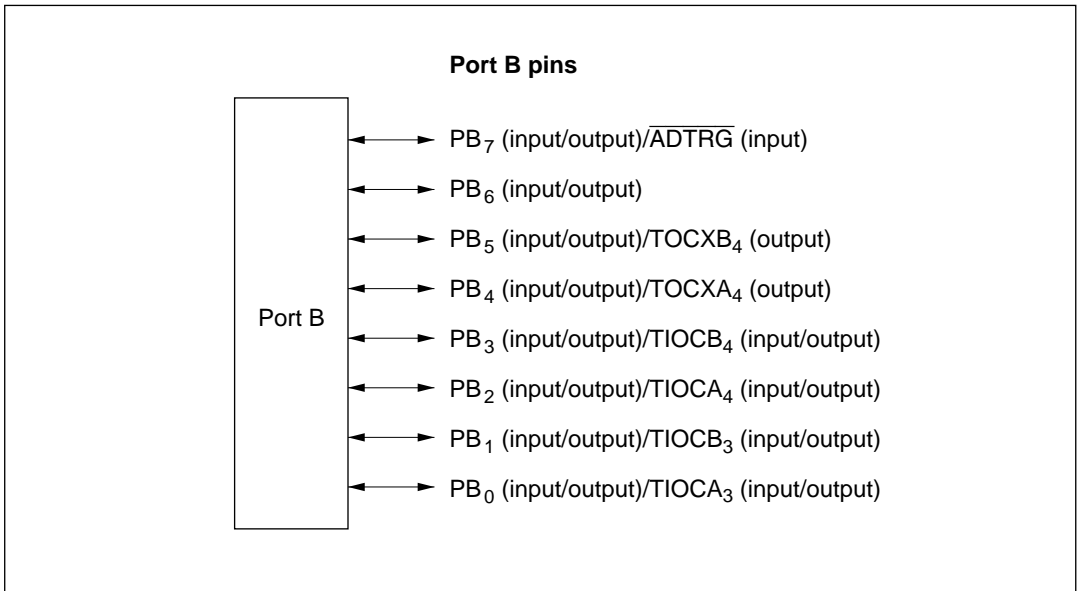

Figure 7-6 Port B Pin Configuration

7.7.2 Register Descriptions

Table 7-11 summarizes the registers of port B.

Table 7-11 Port B Registers

Address*	Name	Abbreviation	R/W	Initial Value
H'FFD4	Port B data direction register	PBDDR	W	H'00
H'FFD6	Port B data register	PBDR	R/W	H'00

Note: * Lower 16 bits of the address.

Port B Data Direction Register (PBDDR): PBDDR is an 8-bit write-only register that can select input or output for each pin in port B.

Bit	7	6	5	4	3	2	1	0
	PB ₇ DDR	PB ₆ DDR	PB ₅ DDR	PB ₄ DDR	PB ₃ DDR	PB ₂ DDR	PB ₁ DDR	PB ₀ DDR
Initial value	0	0	0	0	0	0	0	0
Read/Write	W	W	W	W	W	W	W	W

Port B data direction 7 to 0

These bits select input or output for port B pins

A pin in port B becomes an output pin if the corresponding PBDDR bit is set to 1, and an input pin if this bit is cleared to 0.

PBDDR is a write-only register. Its value cannot be read. All bits return 1 when read.

PBDDR is initialized to H'00 by a reset and in hardware standby mode. In software standby mode it retains its previous setting. If a PBDDR bit is set to 1, the corresponding pin maintains its output state in software standby mode.

Port B Data Register (PBDR): PBDR is an 8-bit readable/writable register that stores data for pins PB7 to PB0.

Bit	7	6	5	4	3	2	1	0
	PB ₇	PB ₆	PB ₅	PB ₄	PB ₃	PB ₂	PB ₁	PB ₀
Initial value	0	0	0	0	0	0	0	0
Read/Write	R/W	R/W	R/W	R/W	R/W	R/W	R/W	R/W

Port B data 7 to 0

These bits store data for port B pins

When a bit in PBDDR is set to 1, if port B is read the value of the corresponding PBDR bit is returned directly. When a bit in PBDDR is cleared to 0, if port B is read the corresponding pin level is read.

PBDR is initialized to H'00 by a reset and in hardware standby mode. In software standby mode it retains its previous setting.

7.7.3 Pin Functions

The port B pins are also used for ITU input/output (TIOCB₄, TIOCB₃, TIOCA₄, TIOCA₃) and output (TOCXB₄, TOCXA₄), and $\overline{\text{ADTRG}}$ input. Table 7-12 describes the selection of pin functions.

Table 7-12 Port B Pin Functions

Pin	Pin Functions and Selection Method		
PB ₇ / $\overline{\text{ADTRG}}$	Bit TRGE in ADCR and bit PB ₇ DDR in PBDDR select the pin function as follows		
	PB ₇ DDR	0	1
	Pin function	PB ₇ input	PB ₇ output
	$\overline{\text{ADTRG}}$ input*		
Note: * $\overline{\text{ADTRG}}$ input when TRGE = 1.			
PB ₆	Bit PB ₆ DDR in PBDDR select the pin function as follows		
	PB ₆ DDR	0	1
	Pin function	PB ₆ input	PB ₆ output
PB ₅ / TOCXB ₄	ITU channel 4 settings (bit CMD1 in TFCR and bit EXB4 in TOER) and bit PB ₅ DDR in PBDDR select the pin function as follows		
	EXB4, CMD1	Not both 1	
	PB ₅ DDR	0	1
	Pin function	PB ₅ input	PB ₅ output
PB ₄ / TOCXA ₄	ITU channel 4 settings (bit CMD1 in TFCR and bit EXA4 in TOER) and bit PB ₄ DDR in PBDDR select the pin function as follows		
	EXA4, CMD1	Not both 1	
	PB ₄ DDR	0	1
	Pin function	PB ₄ input	PB ₄ output

Table 7-12 Port B Pin Functions (cont)

Pin Pin Functions and Selection Method

PB₃/TIOCB₄ ITU channel 4 settings (bit PWM4 in TMDR, bit CMD1 in TFCR, bit EB4 in TOER, and bits IOB2 to IOB0 in TIOR4) and bit PB₃DDR in PBDDR select the pin function as follows

ITU channel 4 settings	(1) in table below	(2) in table below	
PB ₃ DDR	—	0	1
Pin function	TIOCB ₄ output	PB ₃ input	PB ₃ output
		TIOCB ₄ input*	

Note: * TIOCB₄ input when CMD1 = PWM4 = 0 and IOB2 = 1.

ITU channel 4 settings	(2)	(2)	(1)	(2)	(1)	
EB4	0	1				
CMD1	—	0			1	
IOB2	—	0	0	0	1	—
IOB1	—	0	0	1	—	—
IOB0	—	0	1	—	—	—

Table 7-12 Port B Pin Functions (cont)

Pin Pin Functions and Selection Method

PB₂/TIOCA₄ ITU channel 4 settings (bit CMD1 in TFCR, bit EA4 in TOER, bit PWM4 in TMDR, and bits IOA2 to IOA0 in TIOR4) and bit PB₂DDR in PBDDR select the pin function as follows

ITU channel 4 settings	(1) in table below	(2) in table below	
PB ₂ DDR	—	0	1
Pin function	TIOCA ₄ output	PB ₂ input	PB ₂ output
		TIOCA ₄ input*	

Note: * TIOCA₄ input when CMD1 = PWM4 = 0 and IOA2 = 1.

DMAC channel 4 settings	(2)	(2)	(1)			(2)	(1)
EA4	0	1					
CMD1	—	0					1
PWM4	—	0				1	—
IOA2	—	0	0	0	1	—	—
IOA1	—	0	0	1	—	—	—
IOA0	—	0	1	—	—	—	—

Table 7-12 Port B Pin Functions (cont)

Pin Pin Functions and Selection Method

PB₁/TIOCB₃ ITU channel 3 settings (bit PWM3 in TMDR, bit CMD1 in TFCR, bit EB3 in TOER, and bits IOB2 to IOB0 in TIOR3) and bit PB₁DDR in PBDDR select the pin function as follows

ITU channel 3 settings	(1) in table below	(2) in table below	
PB ₁ DDR	—	0	1
Pin function	TIOCB ₃ output	PB ₁ input	PB ₁ output
		TIOCB ₃ input*	

Note: * TIOCB₃ input when CMD1 = PWM3 = 0 and IOB2 = 1.

ITU channel 3 settings	(2)	(2)	(1)	(2)	(1)	
EB3	0	1				
CMD1	—	0			1	
IOB2	—	0	0	0	1	—
IOB1	—	0	0	1	—	—
IOB0	—	0	1	—	—	—

Table 7-12 Port B Pin Functions (cont)

Pin Pin Functions and Selection Method

PB₀/TIOCA₃ ITU channel 3 settings (bit CMD1 in TFCR, bit EA3 in TOER, bit PWM3 in TMDR, and bits IOA2 to IOA0 in TIOR3) and bit PB₀DDR in PBDDR select the pin function as follows

ITU channel 3 settings	(1) in table below	(2) in table below	
PB ₀ DDR	—	0	1
Pin function	TIOCA ₃ output	PB ₀ input	PB ₀ output
		TIOCA ₃ input*	

Note: * TIOCA3 input when CMD1 = PWM3 = 0 and IOA2 = 1.

ITU channel 3 settings	(2)	(2)	(1)		(2)	(1)	
EA3	0	1					
CMD1	—	0				1	
PWM3	—	0			1		—
IOA2	—	0	0	0	1	—	—
IOA1	—	0	0	1	—	—	—
IOA0	—	0	1	—	—	—	—

Section 8 16-Bit Integrated Timer Unit (ITU)

8.1 Overview

The H8/3004 and H8/3005 have a built-in 16-bit integrated timer-pulse unit (ITU) with five 16-bit timer channels.

8.1.1 Features

ITU features are listed below.

- Capability to process up to 12 pulse outputs or 10 pulse inputs
- Ten general registers (GRs, two per channel) with independently-assignable output compare or input capture functions
- Selection of eight counter clock sources for each channel:

Internal clocks: ϕ , $\phi/2$, $\phi/4$, $\phi/8$

External clocks: TCLKA, TCLKB, TCLKC, TCLKD

- Five operating modes selectable in all channels:
 - Waveform output by compare match
 - Selection of 0 output, 1 output, or toggle output (only 0 or 1 output in channel 2)
 - Input capture function
 - Rising edge, falling edge, or both edges (selectable)
 - Counter clearing function
 - Counters can be cleared by compare match or input capture
 - Synchronization
 - Two or more timer counters (TCNTs) can be preset simultaneously, or cleared simultaneously by compare match or input capture. Counter synchronization enables synchronous register input and output.

— PWM mode

PWM output can be provided with an arbitrary duty cycle. With synchronization, up to five-phase PWM output is possible

- Phase counting mode selectable in channel 2

Two-phase encoder output can be counted automatically.

- Three additional modes selectable in channels 3 and 4

— Reset-synchronized PWM mode

If channels 3 and 4 are combined, three-phase PWM output is possible with three pairs of complementary waveforms.

— Complementary PWM mode

If channels 3 and 4 are combined, three-phase PWM output is possible with three pairs of non-overlapping complementary waveforms.

— Buffering

Input capture registers can be double-buffered. Output compare registers can be updated automatically.

- High-speed access via internal 16-bit bus

The 16-bit timer counters, general registers, and buffer registers can be accessed at high speed via a 16-bit bus.

- Fifteen interrupt sources

Each channel has two compare match/input capture interrupts and an overflow interrupt. All interrupts can be requested independently.

Table 8-1 summarizes the ITU functions.

Table 8-1 ITU Functions

Item		Channel 0	Channel 1	Channel 2	Channel 3	Channel 4
Clock sources		Internal clocks: \emptyset , $\emptyset/2$, $\emptyset/4$, $\emptyset/8$ External clocks: TCLKA, TCLKB, TCLKC, TCLKD, selectable independently				
General registers (output compare/input capture registers)		GRA0, GRB0	GRA1, GRB1	GRA2, GRB2	GRA3, GRB3	GRA4, GRB4
Buffer registers		—	—	—	BRA3, BRB3	BRA4, BRB4
Input/output pins		TIOCA ₀ , TIOCB ₀	TIOCA ₁ , TIOCB ₁	TIOCA ₂ , TIOCB ₂	TIOCA ₃ , TIOCB ₃	TIOCA ₄ , TIOCB ₄
Output pins		—	—	—	—	TOCXA ₄ , TOCXB ₄
Counter clearing function		GRA0/GRB0 compare match or input capture	GRA1/GRB1 compare match or input capture	GRA2/GRB2 compare match or input capture	GRA3/GRB3 compare match or input capture	GRA4/GRB4 compare match or input capture
Compare match output	0	○	○	○	○	○
	1	○	○	○	○	○
	Toggle	○	○	—	○	○
Input capture function		○	○	○	○	○
Synchronization		○	○	○	○	○
PWM mode		○	○	○	○	○
Reset-synchronized PWM mode		—	—	—	○	○
Complementary PWM mode		—	—	—	○	○
Phase counting mode		—	—	○	—	—
Buffering		—	—	—	○	○
Interrupt sources		Three sources • Compare match/input capture A0 • Compare match/input capture B0 • Overflow	Three sources • Compare match/input capture A1 • Compare match/input capture B1 • Overflow	Three sources • Compare match/input capture A2 • Compare match/input capture B2 • Overflow	Three sources • Compare match/input capture A3 • Compare match/input capture B3 • Overflow	Three sources • Compare match/input capture A4 • Compare match/input capture B4 • Overflow

Legend

○: Available

—: Not available

8.1.2 Block Diagrams

ITU Block Diagram (overall): Figure 8-1 is a block diagram of the ITU.

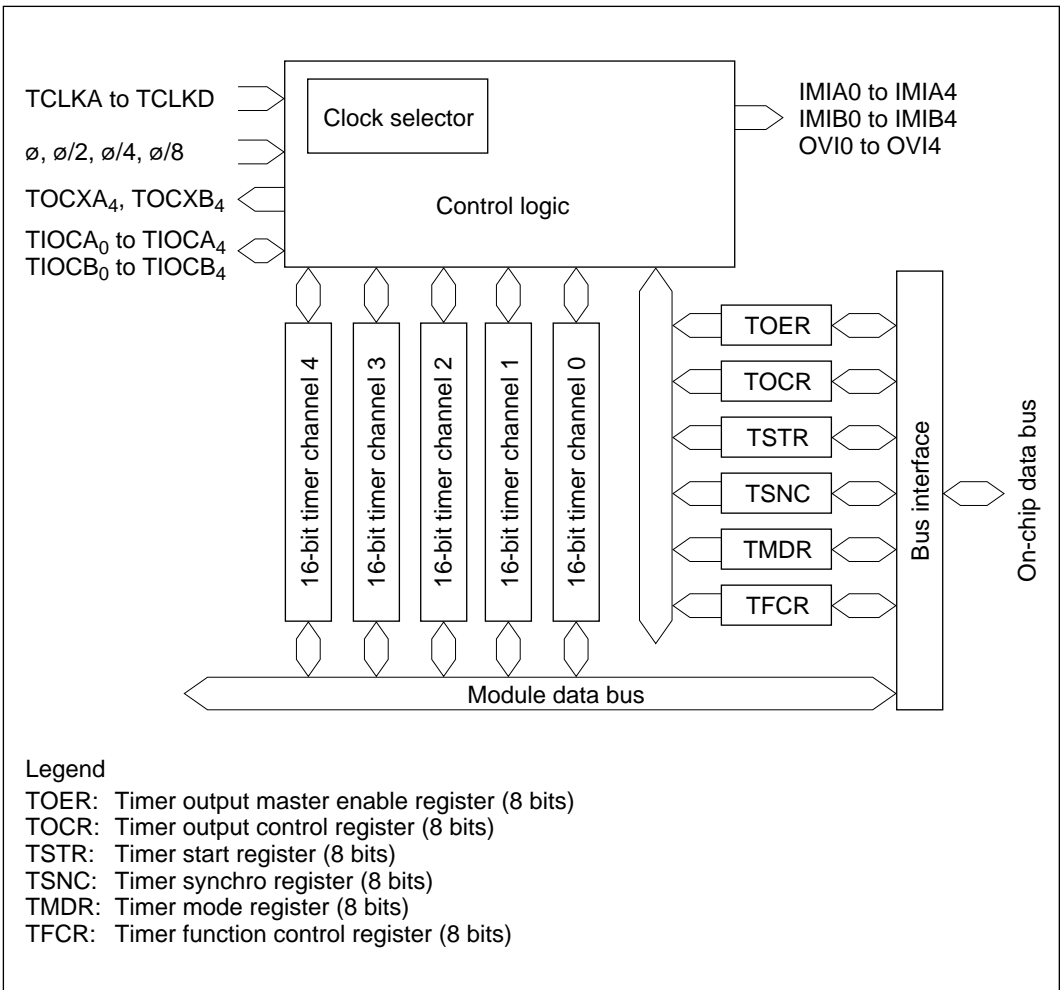

Figure 8-1 ITU Block Diagram (Overall)

Block Diagram of Channels 0 and 1: ITU channels 0 and 1 are functionally identical. Both have the structure shown in figure 8-2.

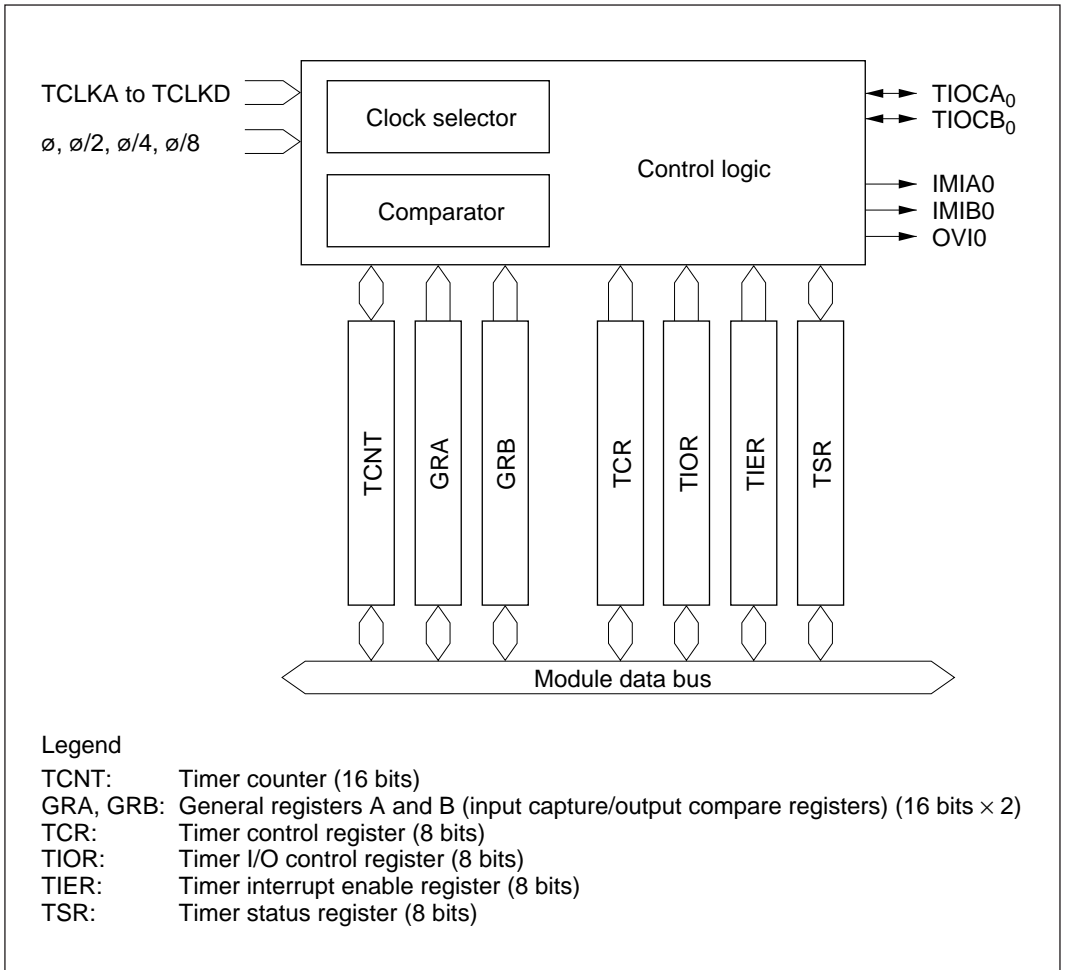

Figure 8-2 Block Diagram of Channels 0 and 1 (for Channel 0)

Block Diagram of Channel 2: Figure 8-3 is a block diagram of channel 2. This is the channel that provides only 0 output and 1 output.

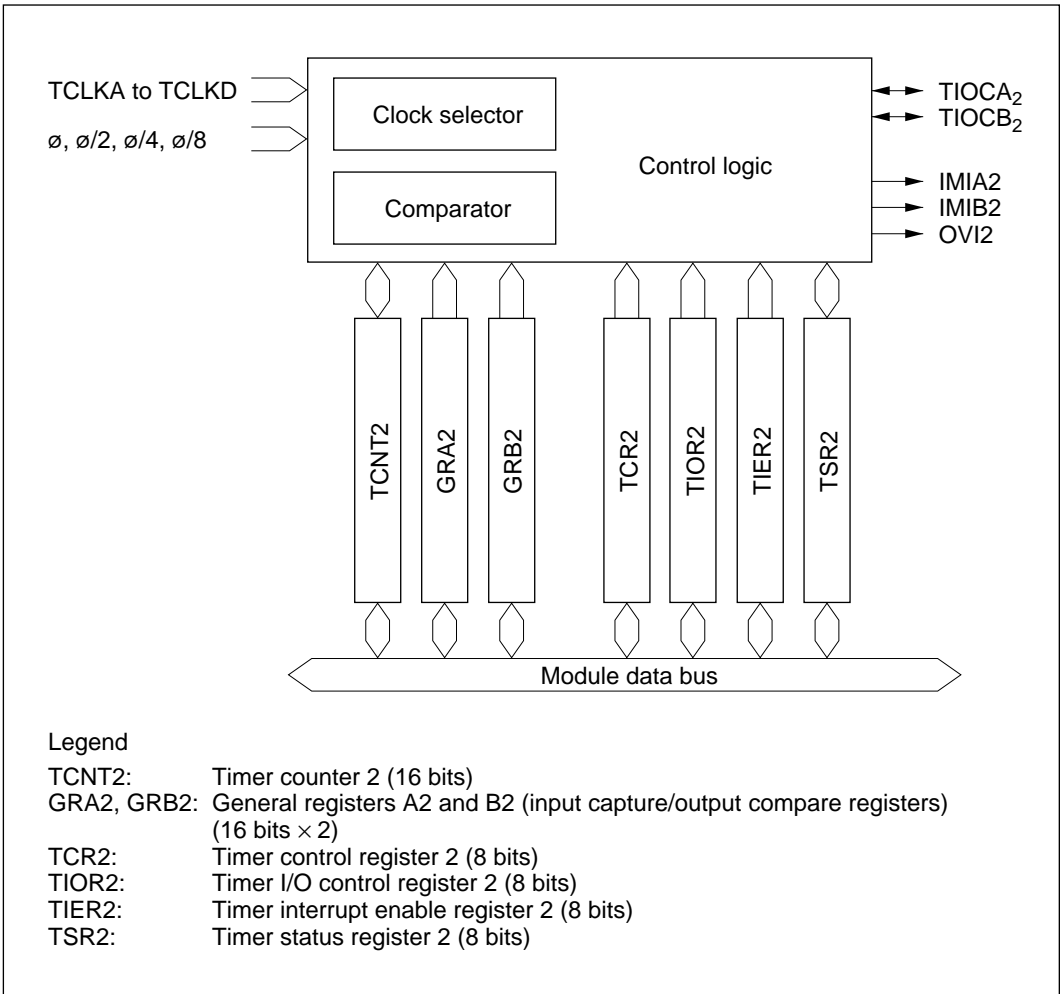

Figure 8-3 Block Diagram of Channel 2

Block Diagrams of Channels 3 and 4: Figure 8-4 is a block diagram of channel 3. Figure 8-5 is a block diagram of channel 4.

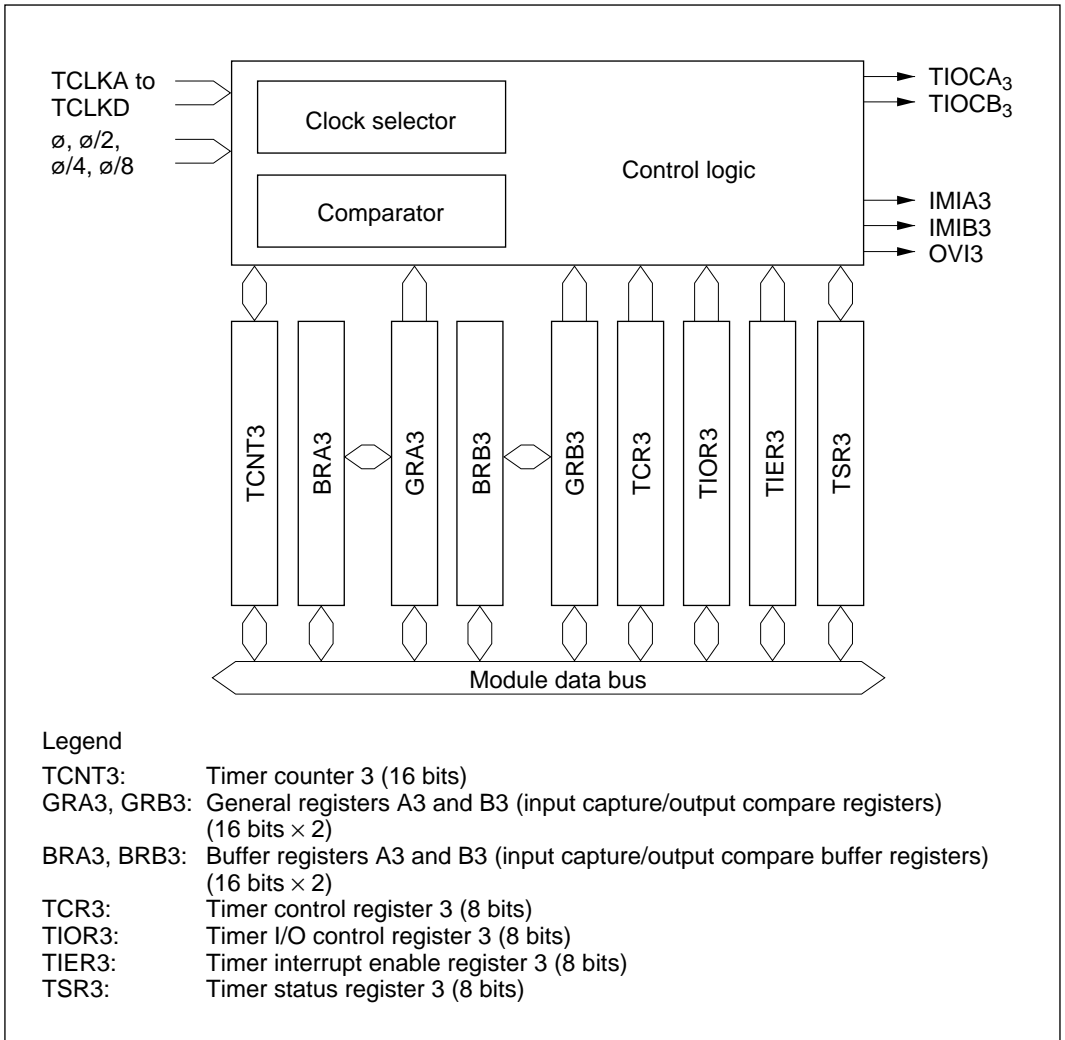

Figure 8-4 Block Diagram of Channel 3

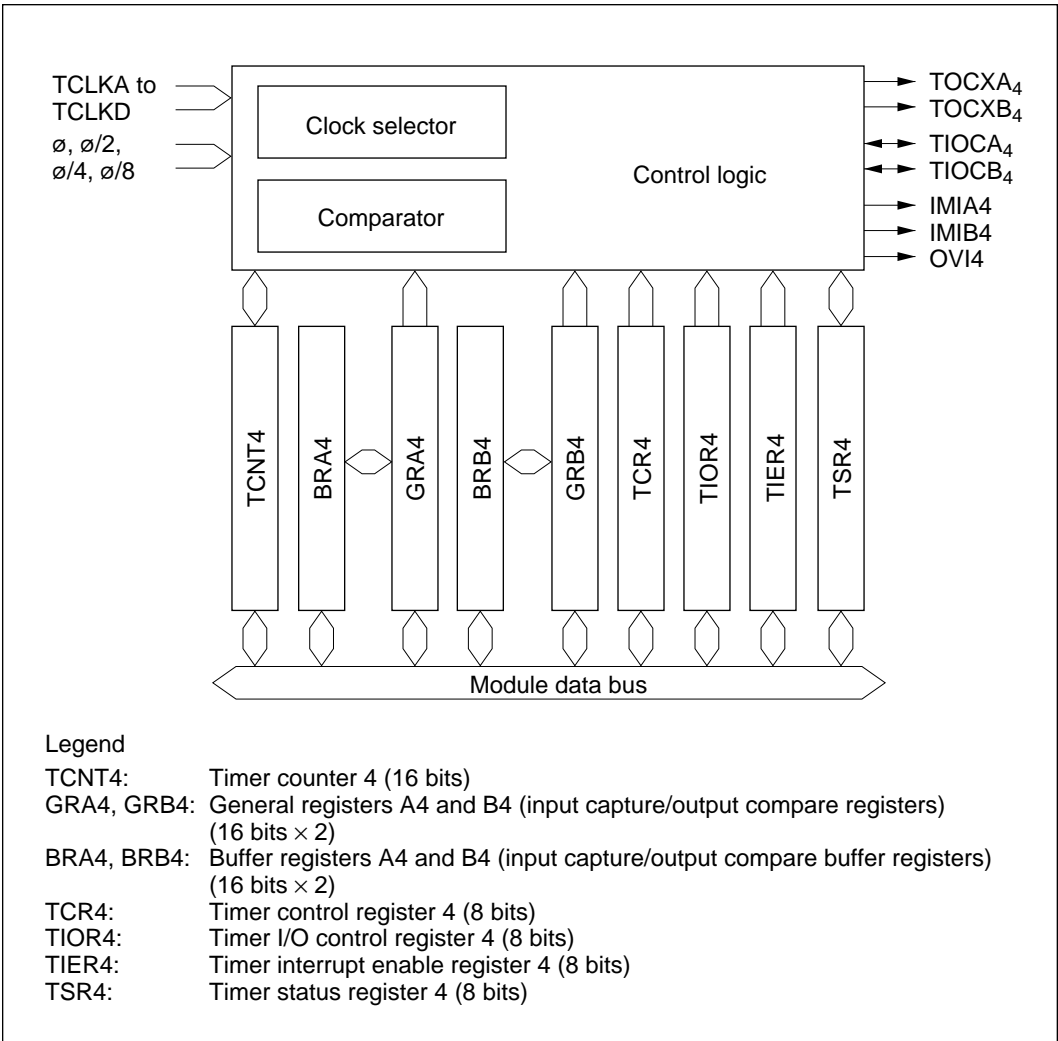

Figure 8-5 Block Diagram of Channel 4

8.1.3 Input/Output Pins

Table 8-2 summarizes the ITU pins.

Table 8-2 ITU Pins

Channel	Name	Abbreviation	Input/Output	Function
Common	Clock input A	TCLKA	Input	External clock A input pin (phase-A input pin in phase counting mode)
	Clock input B	TCLKB	Input	External clock B input pin (phase-B input pin in phase counting mode)
	Clock input C	TCLKC	Input	External clock C input pin
	Clock input D	TCLKD	Input	External clock D input pin
0	Input capture/output compare A0	TIOCA ₀	Input/output	GRA0 output compare or input capture pin PWM output pin in PWM mode
	Input capture/output compare B0	TIOCB ₀	Input/output	GRB0 output compare or input capture pin
1	Input capture/output compare A1	TIOCA ₁	Input/output	GRA1 output compare or input capture pin PWM output pin in PWM mode
	Input capture/output compare B1	TIOCB ₁	Input/output	GRB1 output compare or input capture pin
2	Input capture/output compare A2	TIOCA ₂	Input/output	GRA2 output compare or input capture pin PWM output pin in PWM mode
	Input capture/output compare B2	TIOCB ₂	Input/output	GRB2 output compare or input capture pin
3	Input capture/output compare A3	TIOCA ₃	Input/output	GRA3 output compare or input capture pin PWM output pin in PWM mode, complementary PWM mode, or reset-synchronized PWM mode
	Input capture/output compare B3	TIOCB ₃	Input/output	GRB3 output compare or input capture pin PWM output pin in complementary PWM mode or reset-synchronized PWM mode
4	Input capture/output compare A4	TIOCA ₄	Input/output	GRA4 output compare or input capture pin PWM output pin in PWM mode, complementary PWM mode, or reset-synchronized PWM mode
	Input capture/output compare B4	TIOCB ₄	Input/output	GRB4 output compare or input capture pin PWM output pin in complementary PWM mode or reset-synchronized PWM mode
	Output compare XA4	TOCXA ₄	Output	PWM output pin in complementary PWM mode or reset-synchronized PWM mode
	Output compare XB4	TOCXB ₄	Output	PWM output pin in complementary PWM mode or reset-synchronized PWM mode

8.1.4 Register Configuration

Table 8-3 summarizes the ITU registers.

Table 8-3 ITU Registers

Channel	Address*1	Name	Abbreviation	R/W	Initial Value
Common	H'FF60	Timer start register	TSTR	R/W	H'E0
	H'FF61	Timer synchro register	TSNC	R/W	H'E0
	H'FF62	Timer mode register	TMDR	R/W	H'80
	H'FF63	Timer function control register	TFCR	R/W	H'C0
	H'FF90	Timer output master enable register	TOER	R/W	H'FF
	H'FF91	Timer output control register	TOCR	R/W	H'FF
0	H'FF64	Timer control register 0	TCR0	R/W	H'80
	H'FF65	Timer I/O control register 0	TIOR0	R/W	H'88
	H'FF66	Timer interrupt enable register 0	TIER0	R/W	H'F8
	H'FF67	Timer status register 0	TSR0	R/(W)*2	H'F8
	H'FF68	Timer counter 0 (high)	TCNT0H	R/W	H'00
	H'FF69	Timer counter 0 (low)	TCNT0L	R/W	H'00
	H'FF6A	General register A0 (high)	GRA0H	R/W	H'FF
	H'FF6B	General register A0 (low)	GRA0L	R/W	H'FF
	H'FF6C	General register B0 (high)	GRB0H	R/W	H'FF
	H'FF6D	General register B0 (low)	GRB0L	R/W	H'FF
1	H'FF6E	Timer control register 1	TCR1	R/W	H'80
	H'FF6F	Timer I/O control register 1	TIOR1	R/W	H'88
	H'FF70	Timer interrupt enable register 1	TIER1	R/W	H'F8
	H'FF71	Timer status register 1	TSR1	R/(W)*2	H'F8
	H'FF72	Timer counter 1 (high)	TCNT1H	R/W	H'00
	H'FF73	Timer counter 1 (low)	TCNT1L	R/W	H'00
	H'FF74	General register A1 (high)	GRA1H	R/W	H'FF
	H'FF75	General register A1 (low)	GRA1L	R/W	H'FF
	H'FF76	General register B1 (high)	GRB1H	R/W	H'FF
	H'FF77	General register B1 (low)	GRB1L	R/W	H'FF

- Notes: 1. The lower 16 bits of the address are indicated.
 2. Only 0 can be written, to clear flags.

Table 8-3 ITU Registers (cont)

Channel	Address*1	Name	Abbreviation	R/W	Initial Value
2	H'FF78	Timer control register 2	TCR2	R/W	H'80
	H'FF79	Timer I/O control register 2	TIOR2	R/W	H'88
	H'FF7A	Timer interrupt enable register 2	TIER2	R/W	H'F8
	H'FF7B	Timer status register 2	TSR2	R/(W)*2	H'F8
	H'FF7C	Timer counter 2 (high)	TCNT2H	R/W	H'00
	H'FF7D	Timer counter 2 (low)	TCNT2L	R/W	H'00
	H'FF7E	General register A2 (high)	GRA2H	R/W	H'FF
	H'FF7F	General register A2 (low)	GRA2L	R/W	H'FF
	H'FF80	General register B2 (high)	GRB2H	R/W	H'FF
	H'FF81	General register B2 (low)	GRB2L	R/W	H'FF
3	H'FF82	Timer control register 3	TCR3	R/W	H'80
	H'FF83	Timer I/O control register 3	TIOR3	R/W	H'88
	H'FF84	Timer interrupt enable register 3	TIER3	R/W	H'F8
	H'FF85	Timer status register 3	TSR3	R/(W)*2	H'F8
	H'FF86	Timer counter 3 (high)	TCNT3H	R/W	H'00
	H'FF87	Timer counter 3 (low)	TCNT3L	R/W	H'00
	H'FF88	General register A3 (high)	GRA3H	R/W	H'FF
	H'FF89	General register A3 (low)	GRA3L	R/W	H'FF
	H'FF8A	General register B3 (high)	GRB3H	R/W	H'FF
	H'FF8B	General register B3 (low)	GRB3L	R/W	H'FF
	H'FF8C	Buffer register A3 (high)	BRA3H	R/W	H'FF
	H'FF8D	Buffer register A3 (low)	BRA3L	R/W	H'FF
	H'FF8E	Buffer register B3 (high)	BRB3H	R/W	H'FF
	H'FF8F	Buffer register B3 (low)	BRB3L	R/W	H'FF

Notes: 1. The lower 16 bits of the address are indicated.

2. Only 0 can be written, to clear flags.

Table 8-3 ITU Registers (cont)

Channel	Address*1	Name	Abbreviation	R/W	Initial Value
4	H'FF92	Timer control register 4	TCR4	R/W	H'80
	H'FF93	Timer I/O control register 4	TIOR4	R/W	H'88
	H'FF94	Timer interrupt enable register 4	TIER4	R/W	H'F8
	H'FF95	Timer status register 4	TSR4	R/(W)*2	H'F8
	H'FF96	Timer counter 4 (high)	TCNT4H	R/W	H'00
	H'FF97	Timer counter 4 (low)	TCNT4L	R/W	H'00
	H'FF98	General register A4 (high)	GRA4H	R/W	H'FF
	H'FF99	General register A4 (low)	GRA4L	R/W	H'FF
	H'FF9A	General register B4 (high)	GRB4H	R/W	H'FF
	H'FF9B	General register B4 (low)	GRB4L	R/W	H'FF
	H'FF9C	Buffer register A4 (high)	BRA4H	R/W	H'FF
	H'FF9D	Buffer register A4 (low)	BRA4L	R/W	H'FF
	H'FF9E	Buffer register B4 (high)	BRB4H	R/W	H'FF
	H'FF9F	Buffer register B4 (low)	BRB4L	R/W	H'FF

- Notes: 1. The lower 16 bits of the address are indicated.
2. Only 0 can be written, to clear flags.

8.2 Register Descriptions

8.2.1 Timer Start Register (TSTR)

TSTR is an 8-bit readable/writable register that starts and stops the timer counter (TCNT) in channels 0 to 4.

Bit	7	6	5	4	3	2	1	0
	—	—	—	STR4	STR3	STR2	STR1	STR0
Initial value	1	1	1	0	0	0	0	0
Read/Write	—	—	—	R/W	R/W	R/W	R/W	R/W

Reserved bits
Counter start 4 to 0
These bits start and stop TCNT4 to TCNT0

TSTR is initialized to H'E0 by a reset and in standby mode.

Bits 7 to 5—Reserved: Read-only bits, always read as 1.

Bit 4—Counter Start 4 (STR4): Starts and stops timer counter 4 (TCNT4).

Bit 4

STR4	Description
0	TCNT4 is halted (Initial value)
1	TCNT4 is counting

Bit 3—Counter Start 3 (STR3): Starts and stops timer counter 3 (TCNT3).

Bit 3

STR3	Description
0	TCNT3 is halted (Initial value)
1	TCNT3 is counting

Bit 2—Counter Start 2 (STR2): Starts and stops timer counter 2 (TCNT2).

Bit 2

STR2	Description
0	TCNT2 is halted (Initial value)
1	TCNT2 is counting

Bit 1—Counter Start 1 (STR1): Starts and stops timer counter 1 (TCNT1).

Bit 1		
STR1	Description	
0	TCNT1 is halted	(Initial value)
1	TCNT1 is counting	

Bit 0—Counter Start 0 (STR0): Starts and stops timer counter 0 (TCNT0).

Bit 0		
STR0	Description	
0	TCNT0 is halted	(Initial value)
1	TCNT0 is counting	

8.2.2 Timer Synchro Register (TSNC)

TSNC is an 8-bit readable/writable register that selects whether channels 0 to 4 operate

Bit	7	6	5	4	3	2	1	0
	—	—	—	SYNC4	SYNC3	SYNC2	SYNC1	SYNC0
Initial value	1	1	1	0	0	0	0	0
Read/Write	—	—	—	R/W	R/W	R/W	R/W	R/W

Reserved bits
Timer sync 4 to 0
These bits synchronize channels 4 to 0

independently or synchronously. Channels are synchronized by setting the corresponding bits to 1.

TSNC is initialized to H'E0 by a reset and in standby mode.

Bits 7 to 5—Reserved: Read-only bits, always read as 1.

Bit 4—Timer Sync 4 (SYNC4): Selects whether channel 4 operates independently or synchronously.

Bit 4		
SYNC4	Description	
0	Channel 4's timer counter (TCNT4) operates independently TCNT4 is preset and cleared independently of other channels	(Initial value)

- 1 Channel 4 operates synchronously
TCNT4 can be synchronously preset and cleared

Bit 3—Timer Sync 3 (SYNC3): Selects whether channel 3 operates independently or synchronously.

Bit 3
SYNC3 Description

- | | | |
|---|---|-----------------|
| 0 | Channel 3's timer counter (TCNT3) operates independently
TCNT3 is preset and cleared independently of other channels | (Initial value) |
| 1 | Channel 3 operates synchronously
TCNT3 can be synchronously preset and cleared | |

Bit 2—Timer Sync 2 (SYNC2): Selects whether channel 2 operates independently or synchronously.

Bit 2
SYNC2 Description

- | | | |
|---|---|-----------------|
| 0 | Channel 2's timer counter (TCNT2) operates independently
TCNT2 is preset and cleared independently of other channels | (Initial value) |
| 1 | Channel 2 operates synchronously
TCNT2 can be synchronously preset and cleared | |

Bit 1—Timer Sync 1 (SYNC1): Selects whether channel 1 operates independently or synchronously.

Bit 1
SYNC1 Description

- | | | |
|---|---|-----------------|
| 0 | Channel 1's timer counter (TCNT1) operates independently
TCNT1 is preset and cleared independently of other channels | (Initial value) |
| 1 | Channel 1 operates synchronously
TCNT1 can be synchronously preset and cleared | |

Bit 0—Timer Sync 0 (SYNC0): Selects whether channel 0 operates independently or synchronously.

Bit 0
SYNC0 Description

- | | | |
|---|---|-----------------|
| 0 | Channel 0's timer counter (TCNT0) operates independently
TCNT0 is preset and cleared independently of other channels | (Initial value) |
| 1 | Channel 0 operates synchronously
TCNT0 can be synchronously preset and cleared | |

8.2.3 Timer Mode Register (TMDR)

TMDR is an 8-bit readable/writable register that selects PWM mode for channels 0 to 4. It also

Bit	7	6	5	4	3	2	1	0
	—	MDF	FDIR	PWM4	PWM3	PWM2	PWM1	PWM0
Initial value	1	0	0	0	0	0	0	0
Read/Write	—	R/W	R/W	R/W	R/W	R/W	R/W	R/W

PWM mode 4 to 0
 These bits select PWM mode for channels 4 to 0

Flag direction
 Selects the setting condition for the overflow flag (OVF) in timer status register 2 (TSR2)

Phase counting mode flag
 Selects phase counting mode for channel 2

Reserved bit

selects phase counting mode and the overflow flag (OVF) setting conditions for channel 2.









TMDR is initialized to H'80 by a reset and in standby mode.

Bit 7—Reserved: Read-only bit, always read as 1.

Bit 6—Phase Counting Mode Flag (MDF): Selects whether channel 2 operates normally or in phase counting mode.

Bit 6	Description
0	Channel 2 operates normally (Initial value)
1	Channel 2 operates in phase counting mode

When MDF is set to 1 to select phase counting mode, timer counter 2 (TCNT2) operates as an up/down-counter and pins TCLKA and TCLKB become counter clock input pins. TCNT2 counts both rising and falling edges of TCLKA and TCLKB, and counts up or down as follows.

Counting Direction	Down-Counting				Up-Counting			
TCLKA pin		High		Low		Low		High
TCLKB pin	Low		High		High		Low	

In phase counting mode channel 2 operates as above regardless of the external clock edges selected by bits CKEG1 and CKEG0 and the clock source selected by bits TPSC2 to TPSC0 in timer control register 2 (TCR2). Phase counting mode takes precedence over these settings.

The counter clearing condition selected by the CCLR1 and CCLR0 bits in TCR2 and the compare match/input capture settings and interrupt functions of timer I/O control register 2 (TIOR2), timer interrupt enable register 2 (TIER2), and timer status register 2 (TSR2) remain effective in phase counting mode.

Bit 5—Flag Direction (FDIR): Designates the setting condition for the overflow flag (OVF) in timer status register 2 (TSR2). The FDIR designation is valid in all modes in channel 2.

Bit 5

FDIR	Description	
0	OVF is set to 1 in TSR2 when TCNT2 overflows or underflows	(Initial value)
1	OVF is set to 1 in TSR2 when TCNT2 overflows	

Bit 4—PWM Mode 4 (PWM4): Selects whether channel 4 operates normally or in PWM mode.

Bit 4

PWM4	Description	
0	Channel 4 operates normally	(Initial value)
1	Channel 4 operates in PWM mode	

When bit PWM4 is set to 1 to select PWM mode, pin TIOCA4 becomes a PWM output pin. The output goes to 1 at compare match with general register A4 (GRA4), and to 0 at compare match with general register B4 (GRB4).

If complementary PWM mode or reset-synchronized PWM mode is selected by bits CMD1 and CMD0 in the timer function control register (TFCR), the CMD1 and CMD0 setting takes precedence and the PWM4 setting is ignored.

Bit 3—PWM Mode 3 (PWM3): Selects whether channel 3 operates normally or in PWM mode.

Bit 3		
PWM3	Description	
0	Channel 3 operates normally	(Initial value)
1	Channel 3 operates in PWM mode	

When bit PWM3 is set to 1 to select PWM mode, pin TIOCA3 becomes a PWM output pin. The output goes to 1 at compare match with general register A3 (GRA3), and to 0 at compare match with general register B3 (GRB3).

If complementary PWM mode or reset-synchronized PWM mode is selected by bits CMD1 and CMD0 in the timer function control register (TFCR), the CMD1 and CMD0 setting takes precedence and the PWM3 setting is ignored.

Bit 2—PWM Mode 2 (PWM2): Selects whether channel 2 operates normally or in PWM mode.

Bit 2		
PWM2	Description	
0	Channel 2 operates normally	(Initial value)
1	Channel 2 operates in PWM mode	

When bit PWM2 is set to 1 to select PWM mode, pin TIOCA2 becomes a PWM output pin. The output goes to 1 at compare match with general register A2 (GRA2), and to 0 at compare match with general register B2 (GRB2).

Bit 1—PWM Mode 1 (PWM1): Selects whether channel 1 operates normally or in PWM mode.

Bit 1		
PWM1	Description	
0	Channel 1 operates normally	(Initial value)
1	Channel 1 operates in PWM mode	

When bit PWM1 is set to 1 to select PWM mode, pin TIOCA1 becomes a PWM output pin. The output goes to 1 at compare match with general register A1 (GRA1), and to 0 at compare match with general register B1 (GRB1).

Bit 0—PWM Mode 0 (PWM0): Selects whether channel 0 operates normally or in PWM mode.

Bit 0

PWM0	Description	
0	Channel 0 operates normally	(Initial value)
1	Channel 0 operates in PWM mode	

When bit PWM0 is set to 1 to select PWM mode, pin TIOCA0 becomes a PWM output pin. The output goes to 1 at compare match with general register A0 (GRA0), and to 0 at compare match with general register B0 (GRB0).

8.2.4 Timer Function Control Register (TFCR)

TFCR is an 8-bit readable/writable register that selects complementary PWM mode, reset-synchronized PWM mode, and buffering for channels 3 and 4.

Bit	7	6	5	4	3	2	1	0
	—	—	CMD1	CMD0	BFB4	BFA4	BFB3	BFA3
Initial value	1	1	0	0	0	0	0	0
Read/Write	—	—	R/W	R/W	R/W	R/W	R/W	R/W

Reserved bits

Combination mode 1/0
These bits select complementary PWM mode or reset-synchronized PWM mode for channels 3 and 4

Buffer mode B4 and A4
These bits select buffering of general registers (GRB4 and GRA4) by buffer registers (BRB4 and BRA4) in channel 4

Buffer mode B3 and A3
These bits select buffering of general registers (GRB3 and GRA3) by buffer registers (BRB3 and BRA3) in channel 3

TFCR is initialized to H'C0 by a reset and in standby mode.

Bits 7 and 6—Reserved: Read-only bits, always read as 1.

Bits 5 and 4—Combination Mode 1 and 0 (CMD1, CMD0): These bits select whether channels 3 and 4 operate in normal mode, complementary PWM mode, or reset-synchronized PWM mode.

Bit 5 CMD1	Bit 4 CMD0	Description	
0	0	Channels 3 and 4 operate normally	(Initial value)
	1		
1	0	Channels 3 and 4 operate together in complementary PWM mode	
	1	Channels 3 and 4 operate together in reset-synchronized PWM mode	

Before selecting reset-synchronized PWM mode or complementary PWM mode, halt the timer counter or counters that will be used in these modes.

When these bits select complementary PWM mode or reset-synchronized PWM mode, they take precedence over the setting of the PWM mode bits (PWM4 and PWM3) in TMDR. Settings of timer sync bits SYNC4 and SYNC3 in the timer synchro register (TSNC) are valid in complementary PWM mode and reset-synchronized PWM mode, however. When complementary PWM mode is selected, channels 3 and 4 must not be synchronized (do not set bits SYNC3 and SYNC4 both to 1 in TSNC).

Bit 3—Buffer Mode B4 (BFB4): Selects whether GRB4 operates normally in channel 4, or whether GRB4 is buffered by BRB4.

Bit 3 BFB4	Description	
0	GRB4 operates normally	(Initial value)
1	GRB4 is buffered by BRB4	

Bit 2—Buffer Mode A4 (BFA4): Selects whether GRA4 operates normally in channel 4, or whether GRA4 is buffered by BRA4.

Bit 2 BFA4	Description	
0	GRA4 operates normally	(Initial value)
1	GRA4 is buffered by BRA4	

Bit 1—Buffer Mode B3 (BFB3): Selects whether GRB3 operates normally in channel 3, or whether GRB3 is buffered by BRB3.

Bit 1

BFB3	Description
0	GRB3 operates normally (Initial value)
1	GRB3 is buffered by BRB3

Bit 0—Buffer Mode A3 (BFA3): Selects whether GRA3 operates normally in channel 3, or whether GRA3 is buffered by BRA3.

Bit 0

BFA3	Description
0	GRA3 operates normally (Initial value)
1	GRA3 is buffered by BRA3

8.2.5 Timer Output Master Enable Register (TOER)

TOER is an 8-bit readable/writable register that enables or disables output settings for channels 3 and 4.

Bit	7	6	5	4	3	2	1	0
	—	—	EXB4	EXA4	EB3	EB4	EA4	EA3
Initial value	1	1	1	1	1	1	1	1
Read/Write	—	—	R/W	R/W	R/W	R/W	R/W	R/W

Reserved bits

Master enable TOCXA₄, TOCXB₄
 These bits enable or disable output settings for pins TOCXA4 and TOCXB4

Master enable TIOCA₃, TIOCB₃, TIOCA₄, TIOCB₄
 These bits enable or disable output settings for pins TIOCA3, TIOCB3, TIOCA4, and TIOCB4

TOER is initialized to H'FF by a reset and in standby mode.

Bits 7 and 6—Reserved: Read-only bits, always read as 1.

Bit 5—Master Enable TOCXB₄ (EXB4): Enables or disables ITU output at pin TOCXB₄.

Bit 5 EXB4	Description
0	TOCXB ₄ output is disabled regardless of TFCR settings (TOCXB ₄ operates as a generic input/output pin). If XTGD = 0, EXB4 is cleared to 0 when input capture A occurs in channel 1.
1	TOCXB ₄ is enabled for output according to TFCR settings (Initial value)

Bit 4—Master Enable TOCXA₄ (EXA4): Enables or disables ITU output at pin TOCXA₄.

Bit 4 EXA4	Description
0	TOCXA ₄ output is disabled regardless of TFCR settings (TOCXA ₄ operates as a generic input/output pin). If XTGD = 0, EXA4 is cleared to 0 when input capture A occurs in channel 1.
1	TOCXA ₄ is enabled for output according to TFCR settings (Initial value)

Bit 3—Master Enable TIOCB₃ (EB3): Enables or disables ITU output at pin TIOCB₃.

Bit 3 EB3	Description
0	TIOCB ₃ output is disabled regardless of TIOR3 and TFCR settings (TIOCB ₃ operates as a generic input/output pin). If XTGD = 0, EB3 is cleared to 0 when input capture A occurs in channel 1.
1	TIOCB ₃ is enabled for output according to TIOR3 and TFCR settings (Initial value)

Bit 2—Master Enable TIOCB₄ (EB4): Enables or disables ITU output at pin TIOCB₄.

Bit 2

EB4	Description
0	TIOCB ₄ output is disabled regardless of TIOR4 and TFCR settings (TIOCB ₄ operates as a generic input/output pin). If XTGD = 0, EB4 is cleared to 0 when input capture A occurs in channel 1.
1	TIOCB ₄ is enabled for output according to TIOR4 and TFCR settings (Initial value)

Bit 1—Master Enable TIOCA₄ (EA4): Enables or disables ITU output at pin TIOCA₄.

Bit 1

EA4	Description
0	TIOCA ₄ output is disabled regardless of TIOR4, TMDR, and TFCR settings (TIOCA ₄ operates as a generic input/output pin). If XTGD = 0, EA4 is cleared to 0 when input capture A occurs in channel 1.
1	TIOCA ₄ is enabled for output according to TIOR4, TMDR, and TFCR settings (Initial value)

Bit 0—Master Enable TIOCA₃ (EA3): Enables or disables ITU output at pin TIOCA₃.

Bit 0

EA3	Description
0	TIOCA ₃ output is disabled regardless of TIOR3, TMDR, and TFCR settings (TIOCA ₃ operates as a generic input/output pin). If XTGD = 0, EA3 is cleared to 0 when input capture A occurs in channel 1.
1	TIOCA ₃ is enabled for output according to TIOR3, TMDR, and TFCR settings (Initial value)

8.2.6 Timer Output Control Register (TOCR)

TOCR is an 8-bit readable/writable register that selects externally triggered disabling of output in complementary PWM mode and reset-synchronized PWM mode, and inverts the output levels.

Bit	7	6	5	4	3	2	1	0
	—	—	—	XTGD	—	—	OLS4	OLS3
Initial value	1	1	1	1	1	1	1	1
Read/Write	—	—	—	R/W	—	—	R/W	R/W

Reserved bits (bits 7, 6, 5)
External trigger disable (bit 4)
 Selects externally triggered disabling of output in complementary PWM mode and reset-synchronized PWM mode
Reserved bits (bits 3, 2)
Output level select 3, 4 (bits 1, 0)
 These bits select output levels in complementary PWM mode and reset-synchronized PWM mode

The settings of the XTGD, OLS4, and OLS3 bits are valid only in complementary PWM mode and reset-synchronized PWM mode. These settings do not affect other modes.

TOCR is initialized to H'FF by a reset and in standby mode.

Bits 7 to 5—Reserved: Read-only bits, always read as 1.

Bit 4—External Trigger Disable (XTGD): Selects externally triggered disabling of ITU output in complementary PWM mode and reset-synchronized PWM mode.

Bit 4 XTGD	Description
0	Input capture A in channel 1 is used as an external trigger signal in complementary PWM mode and reset-synchronized PWM mode. When an external trigger occurs, bits 5 to 0 in the timer output master enable register (TOER) are cleared to 0, disabling ITU output.
1	External triggering is disabled (Initial value)

Bits 3 and 2—Reserved: Read-only bits, always read as 1.

Bit 1—Output Level Select 4 (OLS4): Selects output levels in complementary PWM mode and reset-synchronized PWM mode.

Bit 1

OLS4	Description
0	TIOCA ₃ , TIOCA ₄ , and TIOCB ₄ outputs are inverted
1	TIOCA ₃ , TIOCA ₄ , and TIOCB ₄ outputs are not inverted (Initial value)

Bit 0—Output Level Select 3 (OLS3): Selects output levels in complementary PWM mode and reset-synchronized PWM mode.

Bit 0

OLS3	Description
0	TIOCB ₃ , TOCXA ₄ , and TOCXB ₄ outputs are inverted
1	TIOCB ₃ , TOCXA ₄ , and TOCXB ₄ outputs are not inverted (Initial value)

8.2.7 Timer Counters (TCNT)

TCNT is a 16-bit counter. The ITU has five TCNTs, one for each channel.

Channel	Abbreviation	Function
0	TCNT0	Up-counter
1	TCNT1	
2	TCNT2	Phase counting mode: up/down-counter Other modes: up-counter
3	TCNT3	Complementary PWM mode: up/down-counter Other modes: up-counter
4	TCNT4	

Bit	15	14	13	12	11	10	9	8	7	6	5	4	3	2	1	0
	<input type="checkbox"/>	<input type="checkbox"/>	<input type="checkbox"/>	<input type="checkbox"/>	<input type="checkbox"/>	<input type="checkbox"/>	<input type="checkbox"/>	<input type="checkbox"/>	<input type="checkbox"/>	<input type="checkbox"/>	<input type="checkbox"/>	<input type="checkbox"/>	<input type="checkbox"/>	<input type="checkbox"/>	<input type="checkbox"/>	<input type="checkbox"/>
Initial value	0	0	0	0	0	0	0	0	0	0	0	0	0	0	0	0
Read/Write	R/W	R/W	R/W	R/W	R/W	R/W	R/W	R/W	R/W	R/W	R/W	R/W	R/W	R/W	R/W	R/W

Each TCNT is a 16-bit readable/writable register that counts pulse inputs from a clock source. The clock source is selected by bits TPSC2 to TPSC0 in the timer control register (TCR).

TCNT0 and TCNT1 are up-counters. TCNT2 is an up/down-counter in phase counting mode and an up-counter in other modes. TCNT3 and TCNT4 are up/down-counters in complementary PWM mode and up-counters in other modes.

TCNT can be cleared to H'0000 by compare match with general register A or B (GRA or GRB) or by input capture to GRA or GRB (counter clearing function) in the same channel.

When TCNT overflows (changes from H'FFFF to H'0000), the overflow flag (OVF) is set to 1 in the timer status register (TSR) of the corresponding channel.

When TCNT underflows (changes from H'0000 to H'FFFF), the overflow flag (OVF) is set to 1 in TSR of the corresponding channel.

The TCNTs are linked to the CPU by an internal 16-bit bus and can be written or read by either word access or byte access.

Each TCNT is initialized to H'0000 by a reset and in standby mode.

8.2.8 General Registers (GRA, GRB)

The general registers are 16-bit registers. The ITU has 10 general registers, two in each channel.

Channel	Abbreviation	Function
0	GRA0, GRB0	Output compare/input capture register
1	GRA1, GRB1	
2	GRA2, GRB2	
3	GRA3, GRB3	Output compare/input capture register; can be buffered by buffer registers BRA and BRB
4	GRA4, GRB4	

Bit	15	14	13	12	11	10	9	8	7	6	5	4	3	2	1	0
Initial value	1	1	1	1	1	1	1	1	1	1	1	1	1	1	1	1
Read/Write	R/W	R/W	R/W	R/W	R/W	R/W	R/W	R/W	R/W	R/W	R/W	R/W	R/W	R/W	R/W	R/W

A general register is a 16-bit readable/writable register that can function as either an output compare register or an input capture register. The function is selected by settings in the timer I/O control register (TIOR).

When a general register is used as an output compare register, its value is constantly compared with the TCNT value. When the two values match (compare match), the IMFA or IMFB flag is set to 1 in the timer status register (TSR). Compare match output can be selected in TIOR.

When a general register is used as an input capture register, rising edges, falling edges, or both edges of an external input capture signal are detected and the current TCNT value is stored in the general register. The corresponding IMFA or IMFB flag in TSR is set to 1 at the same time. The valid edge or edges of the input capture signal are selected in TIOR.

TIOR settings are ignored in PWM mode, complementary PWM mode, and reset-synchronized PWM mode.

General registers are linked to the CPU by an internal 16-bit bus and can be written or read by either word access or byte access.

General registers are initialized to the output compare function (with no output signal) by a reset and in standby mode. The initial value is H'FFFF.

8.2.9 Buffer Registers (BRA, BRB)

The buffer registers are 16-bit registers. The ITU has four buffer registers, two each in channels 3 and 4.

Channel	Abbreviation	Function
3	BRA3, BRB3	Used for buffering
4	BRA4, BRB4	<ul style="list-style-type: none"> When the corresponding GRA or GRB functions as an output compare register, BRA or BRB can function as an output compare buffer register: the BRA or BRB value is automatically transferred to GRA or GRB at compare match When the corresponding GRA or GRB functions as an input capture register, BRA or BRB can function as an input capture buffer register: the GRA or GRB value is automatically transferred to BRA or BRB at input capture

Bit	15	14	13	12	11	10	9	8	7	6	5	4	3	2	1	0
Initial value	1	1	1	1	1	1	1	1	1	1	1	1	1	1	1	1
Read/Write	R/W	R/W	R/W	R/W	R/W	R/W	R/W	R/W	R/W	R/W	R/W	R/W	R/W	R/W	R/W	R/W

A buffer register is a 16-bit readable/writable register that is used when buffering is selected. Buffering can be selected independently by bits BFB4, BFA4, BFB3, and BFA3 in TFCR.

The buffer register and general register operate as a pair. When the general register functions as an output compare register, the buffer register functions as an output compare buffer register. When the general register functions as an input capture register, the buffer register functions as an input capture buffer register.

The buffer registers are linked to the CPU by an internal 16-bit bus and can be written or read by either word or byte access.

Buffer registers are initialized to H'FFFF by a reset and in standby mode.

8.2.10 Timer Control Registers (TCR)

TCR is an 8-bit register. The ITU has five TCRs, one in each channel.

Channel	Abbreviation	Function
0	TCR0	TCR controls the timer counter. The TCRs in all channels are functionally identical. When phase counting mode is selected in channel 2, the settings of bits CKEG1 and CKEG0 and TPSC2 to TPSC0 in TCR2 are ignored.
1	TCR1	
2	TCR2	
3	TCR3	
4	TCR4	

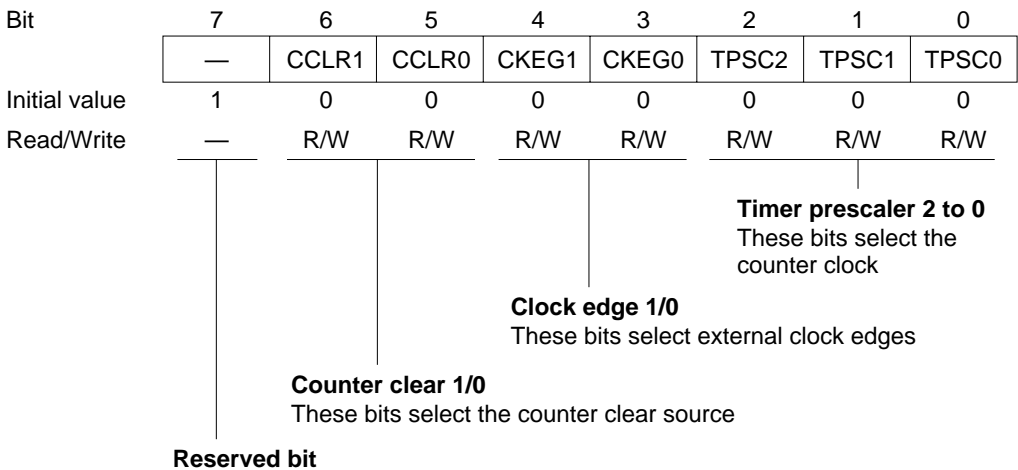

Each TCR is an 8-bit readable/writable register that selects the timer counter clock source, selects the edge or edges of external clock sources, and selects how the counter is cleared.

TCR is initialized to H'80 by a reset and in standby mode.

Bit 7—Reserved: Read-only bit, always read as 1.

Bits 6 and 5—Counter Clear 1/0 (CCLR1, CCLR0): These bits select how TCNT is cleared.

Bit 6 CCLR1	Bit 5 CCLR0	Description
0	0	TCNT is not cleared (Initial value)
	1	TCNT is cleared by GRA compare match or input capture*1
1	0	TCNT is cleared by GRB compare match or input capture*1
	1	Synchronous clear: TCNT is cleared in synchronization with other synchronized timers*2

- Notes:
1. TCNT is cleared by compare match when the general register functions as a compare match register, and by input capture when the general register functions as an input capture register.
 2. Selected in the timer synchro register (TSNC).

Bits 4 and 3—Clock Edge 1/0 (CKEG1, CKEG0): These bits select external clock input edges when an external clock source is used.

Bit 4 CKEG1	Bit 3 CKEG0	Description
0	0	Count rising edges (Initial value)
	1	Count falling edges
1	—	Count both edges

When channel 2 is set to phase counting mode, bits CKEG1 and CKEG0 in TCR2 are ignored. Phase counting takes precedence.

Bits 2 to 0—Timer Prescaler 2 to 0 (TPSC2 to TPSC0): These bits select the counter clock source.

Bit 2 TPSC2	Bit 1 TPSC1	Bit 0 TPSC0	Function
0	0	0	Internal clock: \emptyset (Initial value)
		1	Internal clock: $\emptyset/2$
	1	0	Internal clock: $\emptyset/4$
		1	Internal clock: $\emptyset/8$
1	0	0	External clock A: TCLKA input
		1	External clock B: TCLKB input
	1	0	External clock C: TCLKC input
		1	External clock D: TCLKD input

When bit TPSC2 is cleared to 0 an internal clock source is selected, and the timer counts only falling edges. When bit TPSC2 is set to 1 an external clock source is selected, and the timer counts the edge or edges selected by bits CKEG1 and CKEG0.

When channel 2 is set to phase counting mode ($MDF = 1$ in TMDR), the settings of bits TPSC2 to TPSC0 in TCR2 are ignored. Phase counting takes precedence.

8.2.11 Timer I/O Control Register (TIOR)

TIOR is an 8-bit register. The ITU has five TIORs, one in each channel.

Channel	Abbreviation	Function
0	TIOR0	TIOR controls the general registers. Some functions differ in PWM mode. TIOR3 and TIOR4 settings are ignored when complementary PWM mode or reset-synchronized PWM mode is selected in channels 3 and 4.
1	TIOR1	
2	TIOR2	
3	TIOR3	
4	TIOR4	

Bit	7	6	5	4	3	2	1	0
	—	IOB2	IOB1	IOB0	—	IOA2	IOA1	IOA0
Initial value	1	0	0	0	1	0	0	0
Read/Write	—	R/W	R/W	R/W	—	R/W	R/W	R/W

I/O control B2 to B0
 These bits select GRB functions

Reserved bit

I/O control A2 to A0
 These bits select GRA functions

Reserved bit

Each TIOR is an 8-bit readable/writable register that selects the output compare or input capture function for GRA and GRB, and specifies the functions of the TIOCA and TIOCB pins. If the output compare function is selected, TIOR also selects the type of output. If input capture is selected, TIOR also selects the edge or edges of the input capture signal.

TIOR is initialized to H'88 by a reset and in standby mode.

Bit 7—Reserved: Read-only bit, always read as 1.

Bits 6 to 4—I/O Control B2 to B0 (IOB2 to IOB0): These bits select the GRB function.

Bit 6 IOB2	Bit 5 IOB1	Bit 4 IOB0	Function
0	0	0	GRB is an output compare register
		1	No output at compare match (Initial value) 0 output at GRB compare match*1
	1	0	1 output at GRB compare match*1
		1	Output toggles at GRB compare match (1 output in channel 2)*1, *2
1	0	0	GRB is an input capture register
		1	GRB captures rising edge of input GRB captures falling edge of input
	1	0	GRB captures both edges of input
		1	

- Notes: 1. After a reset, the output is 0 until the first compare match.
 2. Channel 2 output cannot be toggled by compare match. This setting selects 1 output instead.

Bit 3—Reserved: Read-only bit, always read as 1.

Bits 2 to 0—I/O Control A2 to A0 (IOA2 to IOA0): These bits select the GRA function.

Bit 2 IOA2	Bit 1 IOA1	Bit 0 IOA0	Function	
0	0	0	GRA is an output compare register	No output at compare match (Initial value)
		1		0 output at GRA compare match*1
	1	0	GRA is an input capture register	1 output at GRA compare match*1
		1		Output toggles at GRA compare match (1 output in channel 2)*1, *2
1	0	0	GRA is an input capture register	GRA captures rising edge of input
		1		GRA captures falling edge of input
	1	0	GRA is an input capture register	GRA captures both edges of input
		1		

Notes: 1. After a reset, the output is 0 until the first compare match.

2. Channel 2 output cannot be toggled by compare match. This setting selects 1 output instead.

8.2.12 Timer Status Register (TSR)

TSR is an 8-bit register. The ITU has five TSRs, one in each channel.

Channel	Abbreviation	Function
0	TSR0	Indicates input capture, compare match, and overflow status
1	TSR1	
2	TSR2	
3	TSR3	
4	TSR4	

Bit	7	6	5	4	3	2	1	0
	—	—	—	—	—	OVF	IMFB	IMFA
Initial value	1	1	1	1	1	0	0	0
Read/Write	—	—	—	—	—	R/(W)*	R/(W)*	R/(W)*

Reserved bits

Overflow flag
Status flag indicating overflow or underflow

Input capture/compare match flag B
Status flag indicating GRB compare match or input capture

Input capture/compare match flag A
Status flag indicating GRA compare match or input capture

Note: * Only 0 can be written, to clear the flag.

Each TSR is an 8-bit readable/writable register containing flags that indicate TCNT overflow or underflow and GRA or GRB compare match or input capture. These flags are interrupt sources and generate CPU interrupts if enabled by corresponding bits in the timer interrupt enable register (TIER).

TSR is initialized to H'F8 by a reset and in standby mode.

Bits 7 to 3—Reserved: Read-only bits, always read as 1.

Bit 2—Overflow Flag (OVF): This status flag indicates TCNT overflow or underflow.

Bit 2

OVF	Description
0	[Clearing condition] Read OVF when OVF = 1, then write 0 in OVF (Initial value)
1	[Setting condition] TCNT overflowed from H'FFFF to H'0000, or underflowed from H'0000 to H'FFFF*

Notes: * TCNT underflow occurs when TCNT operates as an up/down-counter. Underflow occurs only under the following conditions:

1. Channel 2 operates in phase counting mode (MDF = 1 in TMDR)
2. Channels 3 and 4 operate in complementary PWM mode (CMD1 = 1 and CMD0 = 0 in TFCR)

Bit 1—Input Capture/Compare Match Flag B (IMFB): This status flag indicates GRB compare match or input capture events.

Bit 1 IMFB	Description	
0	[Clearing condition] Read IMFB when IMFB = 1, then write 0 in IMFB	(Initial value)
1	[Setting conditions] TCNT = GRB when GRB functions as a compare match register. TCNT value is transferred to GRB by an input capture signal, when GRB functions as an input capture register.	

Bit 0—Input Capture/Compare Match Flag A (IMFA): This status flag indicates GRA compare match or input capture events.

Bit 0 IMFA	Description	
0	[Clearing condition] Read IMFA when IMFA = 1, then write 0 in IMFA.	(Initial value)
1	[Setting conditions] TCNT = GRA when GRA functions as a compare match register. TCNT value is transferred to GRA by an input capture signal, when GRA functions as an input capture register.	

8.2.13 Timer Interrupt Enable Register (TIER)

TIER is an 8-bit register. The ITU has five TIERS, one in each channel.

Channel	Abbreviation	Function
0	TIER0	Enables or disables interrupt requests.
1	TIER1	
2	TIER2	
3	TIER3	
4	TIER4	

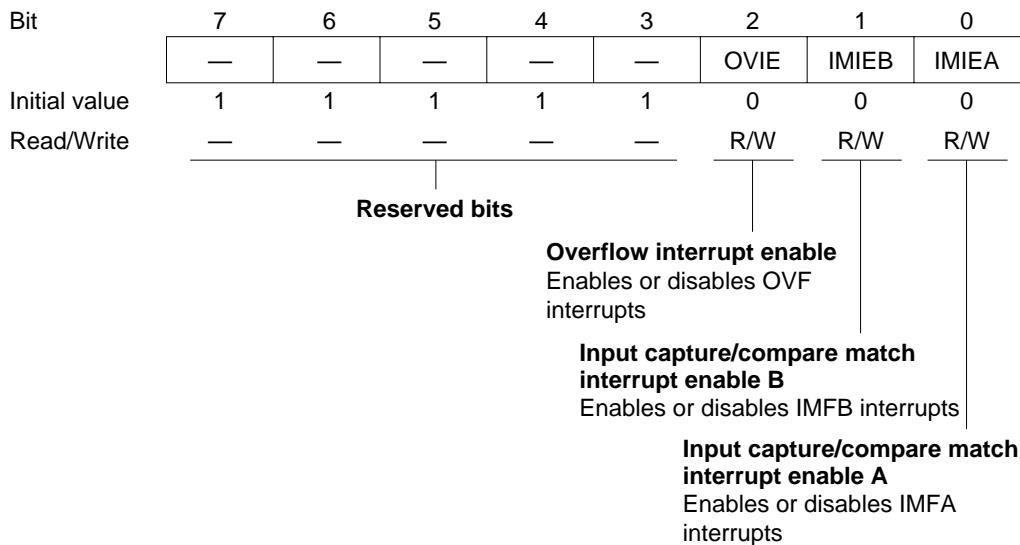

Each TIER is an 8-bit readable/writable register that enables and disables overflow interrupt requests and general register compare match and input capture interrupt requests.

TIER is initialized to H'F8 by a reset and in standby mode.

Bits 7 to 3—Reserved: Read-only bits, always read as 1.

Bit 2—Overflow Interrupt Enable (OVIE): Enables or disables the interrupt requested by the overflow flag (OVF) in TSR when OVF is set to 1.

Bit 2 OVIE	Description
0	OVI interrupt requested by OVF is disabled (Initial value)
1	OVI interrupt requested by OVF is enabled

Bit 1—Input Capture/Compare Match Interrupt Enable B (IMIEB): Enables or disables the interrupt requested by the IMFB flag in TSR when IMFB is set to 1.

Bit 1 IMIEB	Description
0	IMIB interrupt requested by IMFB is disabled (Initial value)
1	IMIB interrupt requested by IMFB is enabled

Bit 0—Input Capture/Compare Match Interrupt Enable A (IMIEA): Enables or disables the interrupt requested by the IMFA flag in TSR when IMFA is set to 1.

Bit 0 IMIEA	Description
0	IMIA interrupt requested by IMFA is disabled (Initial value)
1	IMIA interrupt requested by IMFA is enabled

8.3 CPU Interface

8.3.1 16-Bit Accessible Registers

The timer counters (TCNTs), general registers A and B (GRAs and GRBs), and buffer registers A and B (BRAs and BRBs) are 16-bit registers, and are linked to the CPU by an internal 16-bit data bus. These registers can be written or read a word at a time, or a byte at a time.

Figures 8-6 and 8-7 show examples of word access to a timer counter (TCNT). Figures 8-8, 8-9, 8-10, and 8-11 show examples of byte access to TCNTH and TCNTL.

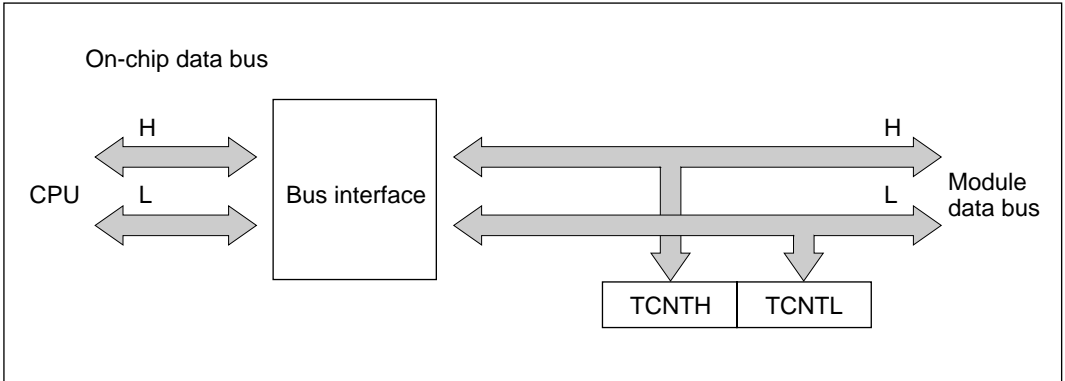

Figure 8-6 Access to Timer Counter (CPU Writes to TCNT, Word)

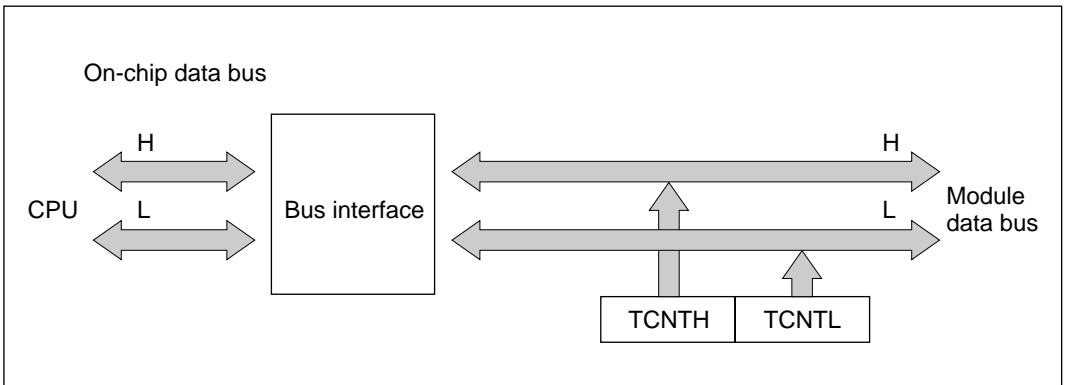

Figure 8-7 Access to Timer Counter (CPU Reads TCNT, Word)

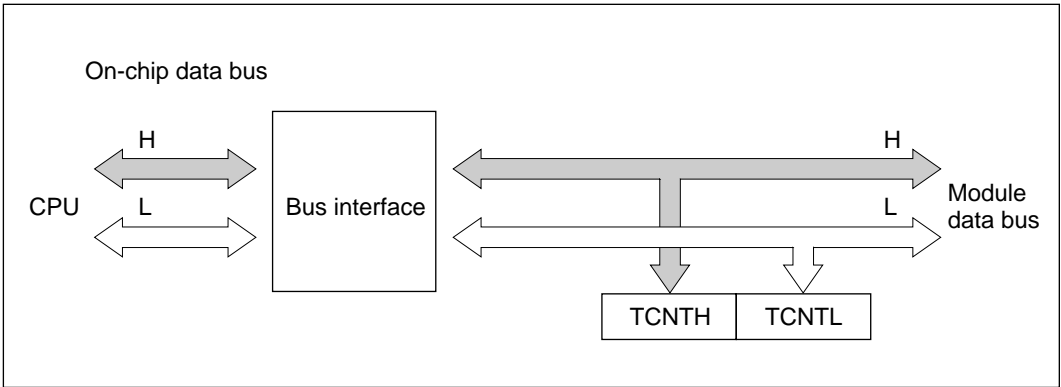

Figure 8-8 Access to Timer Counter (CPU Writes to TCNT, Upper Byte)

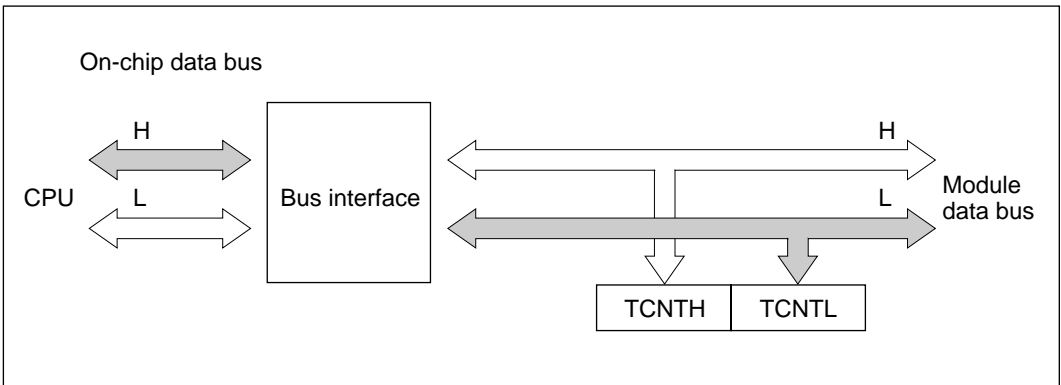

Figure 8-9 Access to Timer Counter (CPU Writes to TCNT, Lower Byte)

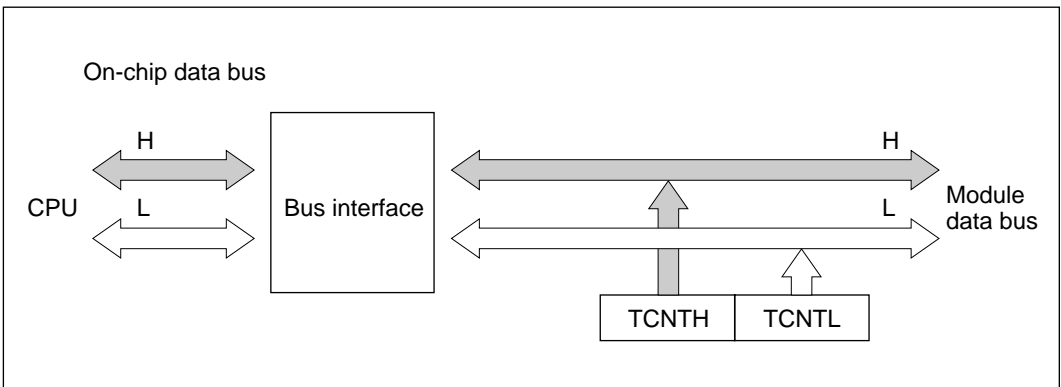

Figure 8-10 Access to Timer Counter (CPU Reads TCNT, Upper Byte)

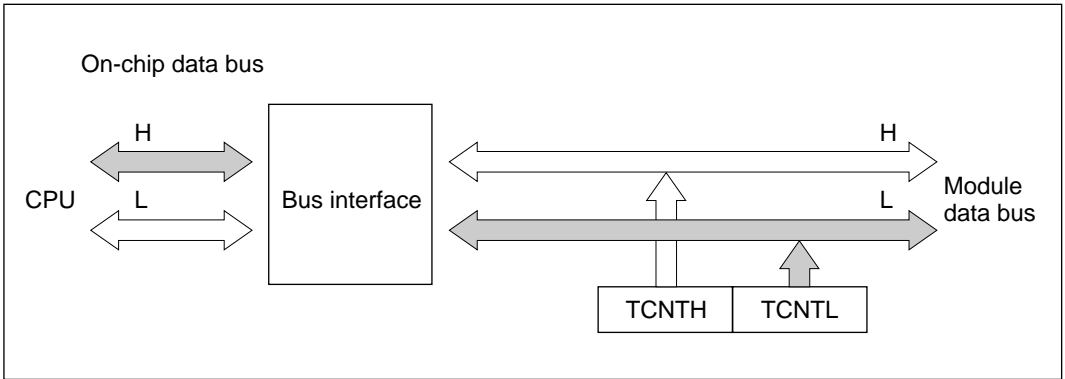

Figure 8-11 Access to Timer Counter (CPU Reads TCNT, Lower Byte)

8.3.2 8-Bit Accessible Registers

The registers other than the timer counters, general registers, and buffer registers are 8-bit registers. These registers are linked to the CPU by an internal 8-bit data bus.

Figures 8-12 and 8-13 show examples of byte read and write access to a TCR.

If a word-size data transfer instruction is executed, two byte transfers are performed.

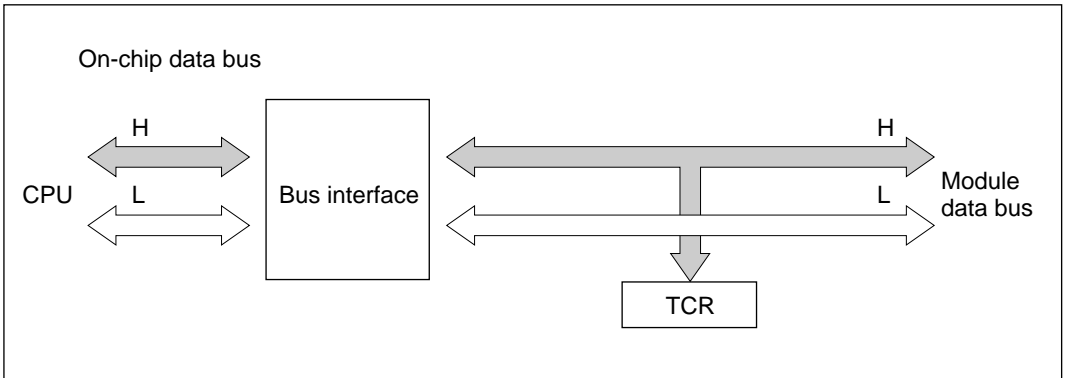

Figure 8-12 TCR Access (CPU Writes to TCR)

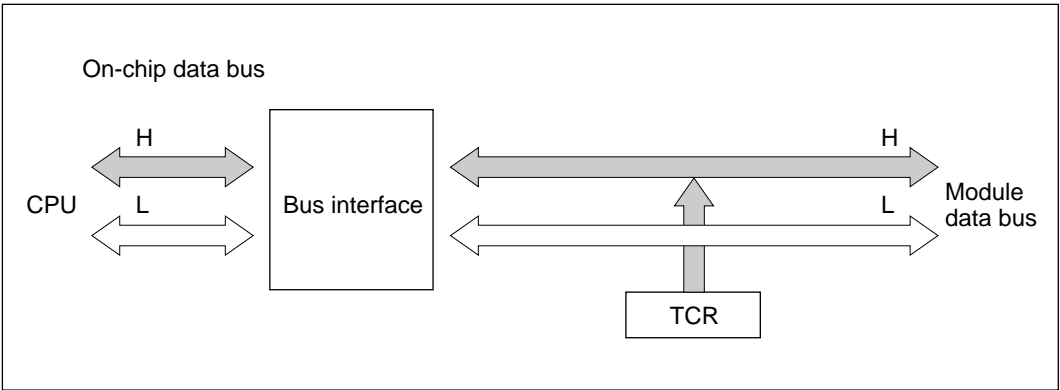

Figure 8-13 TCR Access (CPU Reads TCR)

8.4 Operation

8.4.1 Overview

A summary of operations in the various modes is given below.

Normal Operation: Each channel has a timer counter and general registers. The timer counter counts up, and can operate as a free-running counter, periodic counter, or external event counter. General registers A and B can be used for input capture or output compare.

Synchronous Operation: The timer counters in designated channels are preset synchronously. Data written to the timer counter in any one of these channels is simultaneously written to the timer counters in the other channels as well. The timer counters can also be cleared synchronously if so designated by the CCLR1 and CCLR0 bits in the TCRs.

PWM Mode: A PWM waveform is output from the TIOCA pin. The output goes to 1 at compare match A and to 0 at compare match B. The duty cycle can be varied from 0% to 100% depending on the settings of GRA and GRB. When a channel is set to PWM mode, its GRA and GRB automatically become output compare registers.

Reset-Synchronized PWM Mode: Channels 3 and 4 are paired for three-phase PWM output with complementary waveforms. (The three phases are related by having a common transition point.) When reset-synchronized PWM mode is selected GRA3, GRB3, GRA4, and GRB4 automatically function as output compare registers, TIOCA₃, TIOCB₃, TIOCA₄, TOCXA₄, TIOCB₄, and TOCXB₄ function as PWM output pins, and TCNT3 operates as an up-counter. TCNT4 operates independently, and is not compared with GRA4 or GRB4.

Complementary PWM Mode: Channels 3 and 4 are paired for three-phase PWM output with non-overlapping complementary waveforms. When complementary PWM mode is selected GRA3, GRB3, GRA4, and GRB4 automatically function as output compare registers, and TIOCA₃, TIOCB₃, TIOCA₄, TOCXA₄, TIOCB₄, and TOCXB₄ function as PWM output pins. TCNT3 and TCNT4 operate as up/down-counters.

Phase Counting Mode: The phase relationship between two clock signals input at TCLKA and TCLKB is detected and TCNT2 counts up or down accordingly. When phase counting mode is selected TCLKA and TCLKB become clock input pins and TCNT2 operates as an up/down-counter.

Buffering

- If the general register is an output compare register

When compare match occurs the buffer register value is transferred to the general register.

- If the general register is an input capture register

When input capture occurs the TCNT value is transferred to the general register, and the previous general register value is transferred to the buffer register.

- Complementary PWM mode

The buffer register value is transferred to the general register when TCNT3 and TCNT4 change counting direction.

- Reset-synchronized PWM mode

The buffer register value is transferred to the general register at GRA3 compare match.

8.4.2 Basic Functions

Counter Operation: When one of bits STR0 to STR4 is set to 1 in the timer start register (TSTR), the timer counter (TCNT) in the corresponding channel starts counting. The counting can be free-running or periodic.

- Sample setup procedure for counter

Figure 8-14 shows a sample procedure for setting up a counter.

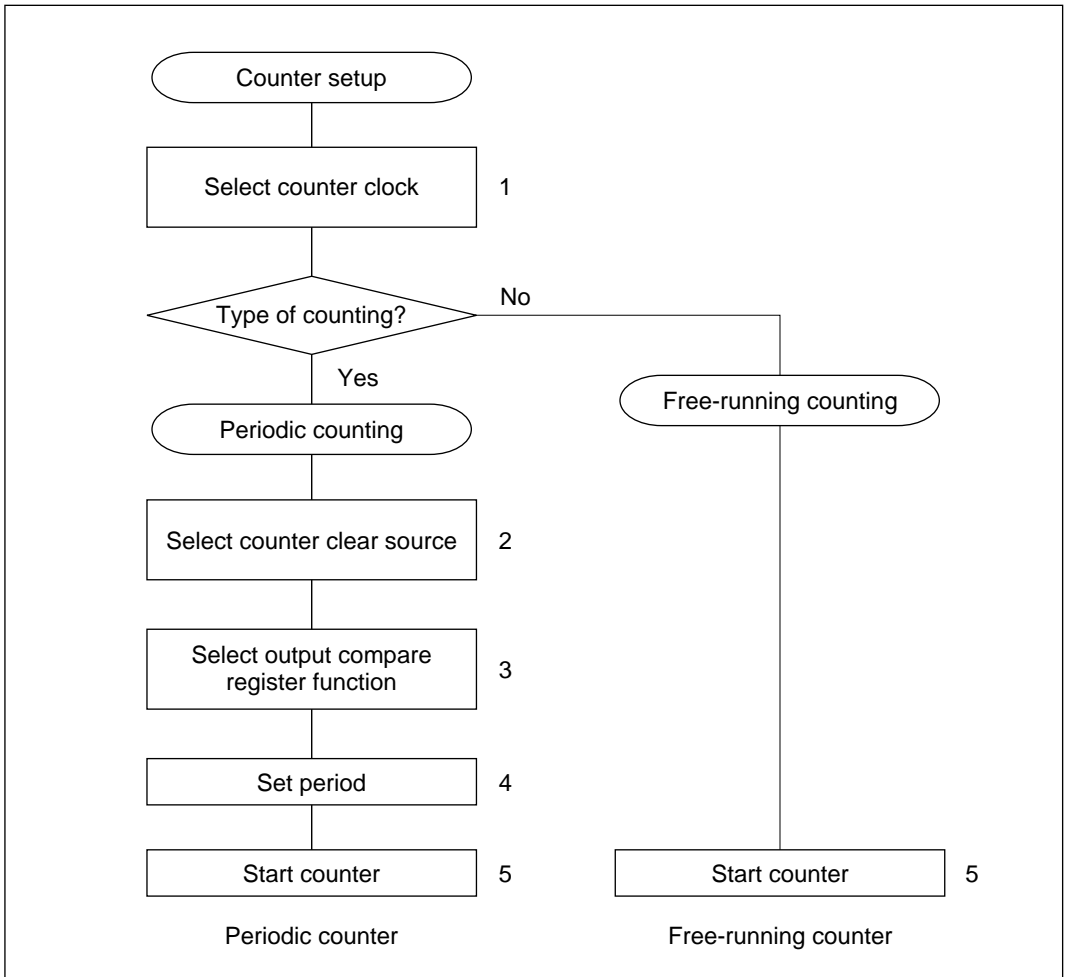

Figure 8-14 Counter Setup Procedure (Example)

1. Set bits TPSC2 to TPSC0 in TCR to select the counter clock source. If an external clock source is selected, set bits CKEG1 and CKEG0 in TCR to select the desired edge(s) of the external clock signal.
2. For periodic counting, set CCLR1 and CCLR0 in TCR to have TCNT cleared at GRA compare match or GRB compare match.
3. Set TIOR to select the output compare function of GRA or GRB, whichever was selected in step 2.
4. Write the count period in GRA or GRB, whichever was selected in step 2.
5. Set the STR bit to 1 in TSTR to start the timer counter.

- Free-running and periodic counter operation

A reset leaves the counters (TCNTs) in ITU channels 0 to 4 all set as free-running counters. A free-running counter starts counting up when the corresponding bit in TSTR is set to 1. When the count overflows from H'FFFF to H'0000, the overflow flag (OVF) is set to 1 in the timer status register (TSR). If the corresponding OVIE bit is set to 1 in the timer interrupt enable register, a CPU interrupt is requested. After the overflow, the counter continues counting up from H'0000. Figure 8-15 illustrates free-running counting.

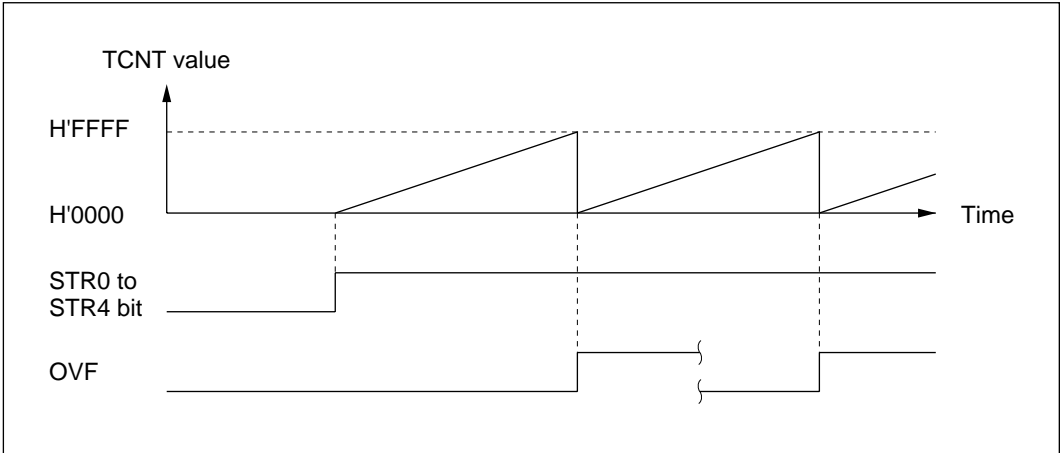

Figure 8-15 Free-Running Counter Operation

When a channel is set to have its counter cleared by compare match, in that channel TCNT operates as a periodic counter. Select the output compare function of GRA or GRB, set bit CCLR1 or CCLR0 in the timer control register (TCR) to have the counter cleared by compare match, and set the count period in GRA or GRB. After these settings, the counter starts counting up as a periodic counter when the corresponding bit is set to 1 in TSTR. When the count matches GRA or GRB, the IMFA or IMFB flag is set to 1 in TSR and the counter is cleared to H'0000. If the corresponding IMIEA or IMIEB bit is set to 1 in TIER, a CPU interrupt is requested at this time. After the compare match, TCNT continues counting up from H'0000. Figure 8-16 illustrates periodic counting.

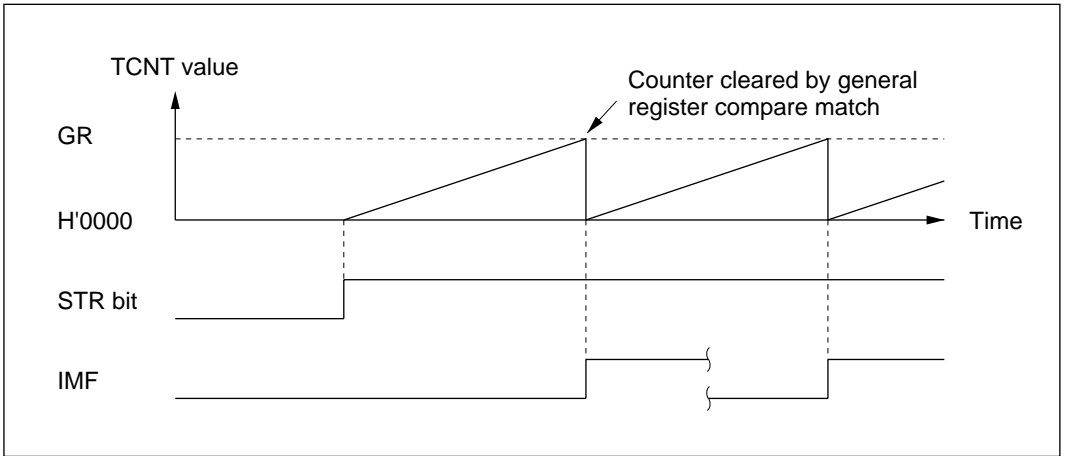

Figure 8-16 Periodic Counter Operation

- Count timing

- Internal clock source

Bits TPSC2 to TPSC0 in TCR select the system clock (ϕ) or one of three internal clock sources obtained by prescaling the system clock ($\phi/2$, $\phi/4$, $\phi/8$).

Figure 8-17 shows the timing.

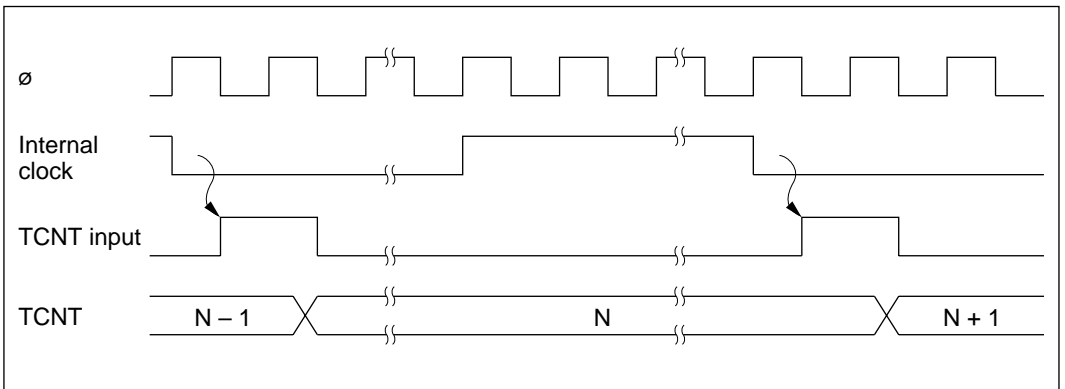

Figure 8-17 Count Timing for Internal Clock Sources

— External clock source

Bits TPSC2 to TPSC0 in TCR select an external clock input pin (TCLKA to TCLKD), and its valid edge or edges are selected by bits CKEG1 and CKEG0. The rising edge, falling edge, or both edges can be selected.

The pulse width of the external clock signal must be at least 1.5 system clocks when a single edge is selected, and at least 2.5 system clocks when both edges are selected. Shorter pulses will not be counted correctly.

Figure 8-18 shows the timing when both edges are detected.

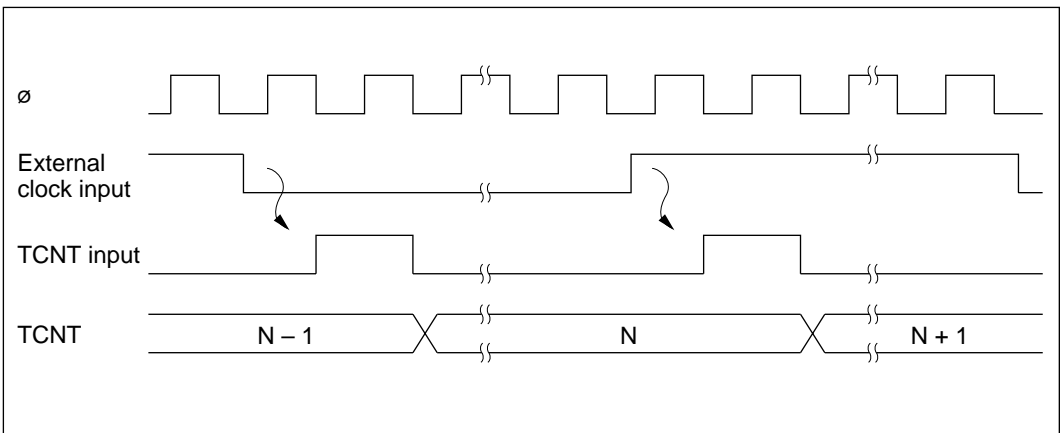

Figure 8-18 Count Timing for External Clock Sources (when Both Edges are Detected)

Waveform Output by Compare Match: In ITU channels 0, 1, 3, and 4, compare match A or B can cause the output at the TIOCA or TIOCB pin to go to 0, go to 1, or toggle. In channel 2 the output can only go to 0 or go to 1.

- Sample setup procedure for waveform output by compare match

Figure 8-19 shows a sample procedure for setting up waveform output by compare match.

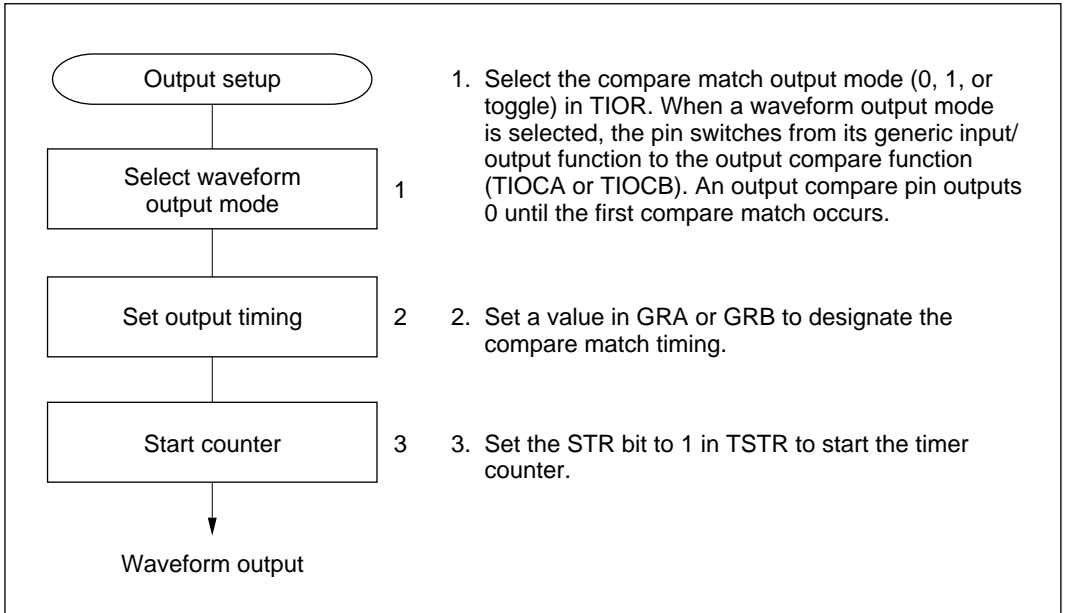

Figure 8-19 Setup Procedure for Waveform Output by Compare Match (Example)

- Examples of waveform output

Figure 8-20 shows examples of 0 and 1 output. TCNT operates as a free-running counter, 0 output is selected for compare match A, and 1 output is selected for compare match B. When the pin is already at the selected output level, the pin level does not change.

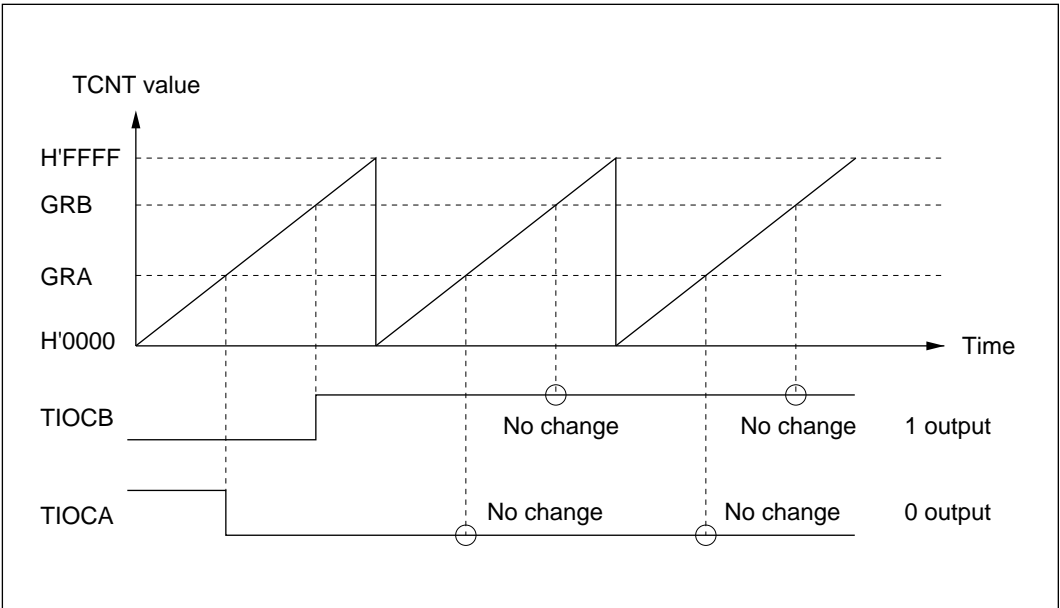

Figure 8-20 0 and 1 Output (Examples)

Figure 8-21 shows examples of toggle output. TCNT operates as a periodic counter, cleared by compare match B. Toggle output is selected for both compare match A and B.

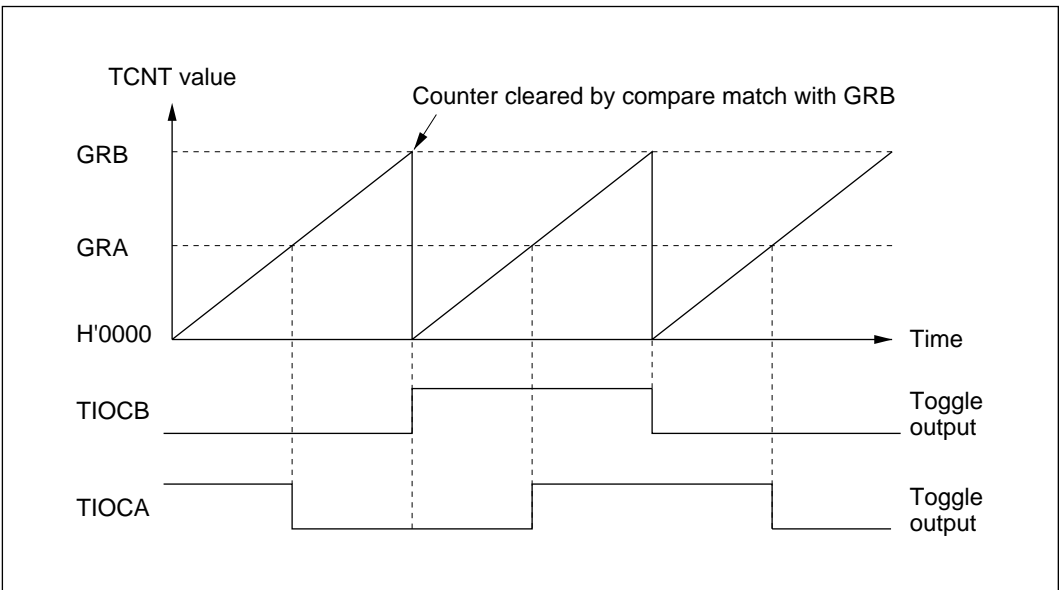

Figure 8-21 Toggle Output (Example)

- Output compare timing

The compare match signal is generated in the last state in which TCNT and the general register match (when TCNT changes from the matching value to the next value). When the compare match signal is generated, the output value selected in TIOR is output at the output compare pin (TIOCA or TIOCB). When TCNT matches a general register, the compare match signal is not generated until the next counter clock pulse.

Figure 8-22 shows the output compare timing.

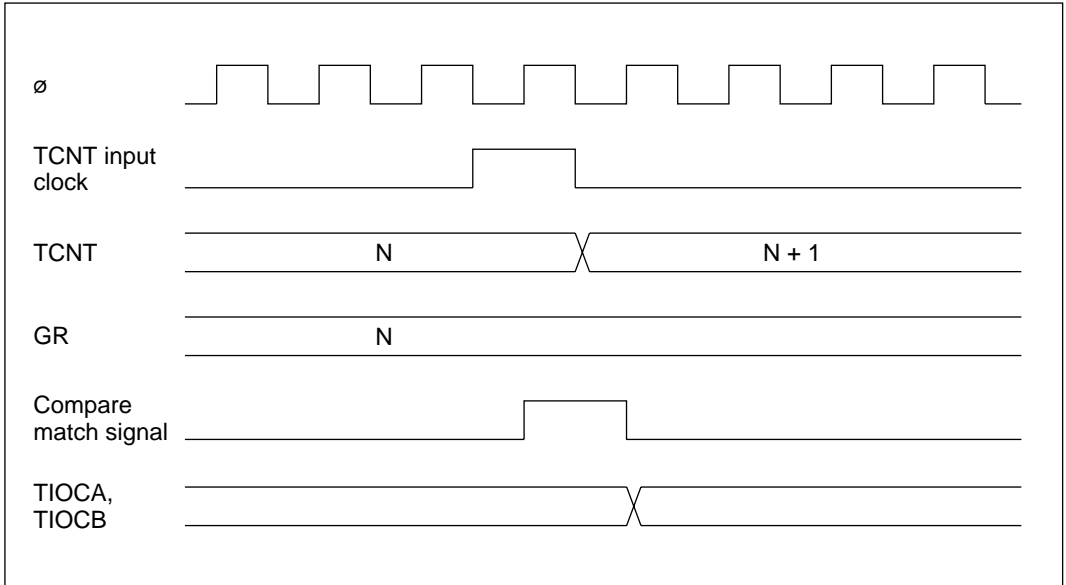

Figure 8-22 Output Compare Timing

Input Capture Function: The TCNT value can be captured into a general register when a transition occurs at an input capture/output compare pin (TIOCA or TIOCB). Capture can take place on the rising edge, falling edge, or both edges. The input capture function can be used to measure pulse width or period.

- Sample setup procedure for input capture

Figure 8-23 shows a sample procedure for setting up input capture.

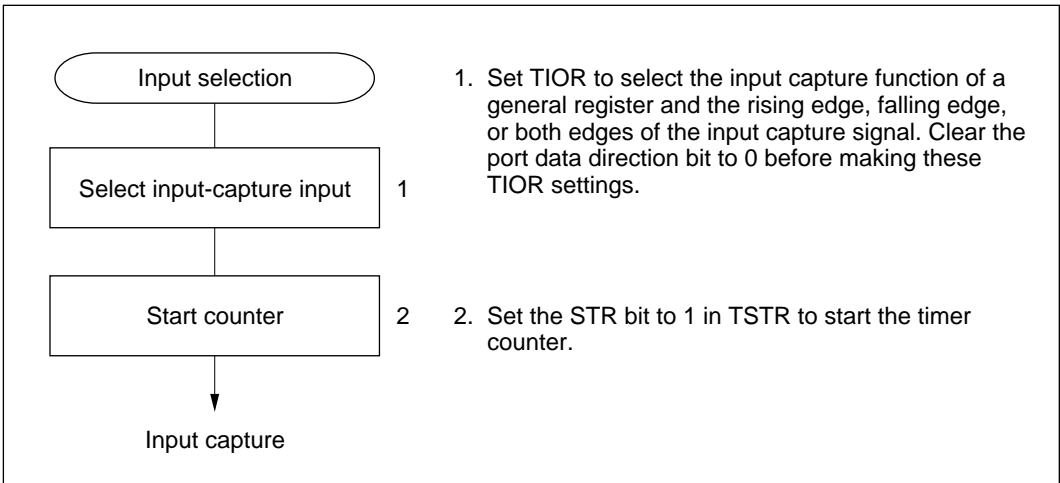

Figure 8-23 Setup Procedure for Input Capture (Example)

- Examples of input capture

Figure 8-24 illustrates input capture when the falling edge of TIOCB and both edges of TIOCA are selected as capture edges. TCNT is cleared by input capture into GRB.

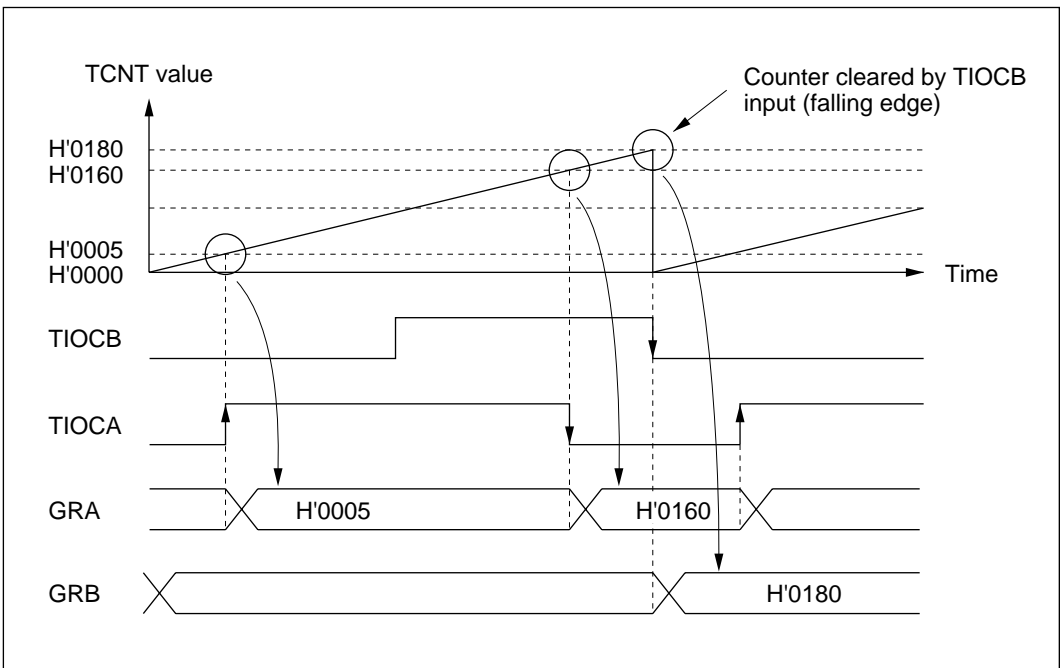

Figure 8-24 Input Capture (Example)

- Input capture signal timing

Input capture on the rising edge, falling edge, or both edges can be selected by settings in TIOR. Figure 8-25 shows the timing when the rising edge is selected. The pulse width of the input capture signal must be at least 1.5 system clocks for single-edge capture, and 2.5 system clocks for capture of both edges.

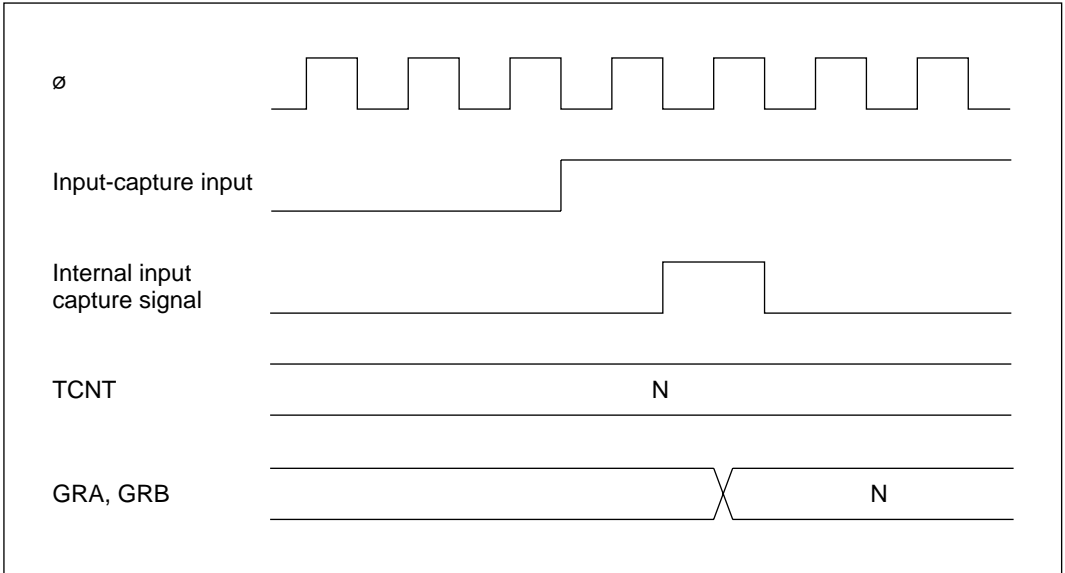

Figure 8-25 Input Capture Signal Timing

8.4.3 Synchronization

The synchronization function enables two or more timer counters to be synchronized by writing the same data to them simultaneously (synchronous preset). With appropriate TCR settings, two or more timer counters can also be cleared simultaneously (synchronous clear). Synchronization enables additional general registers to be associated with a single time base. Synchronization can be selected for all channels (0 to 4).

Sample Setup Procedure for Synchronization: Figure 8-26 shows a sample procedure for setting up synchronization.

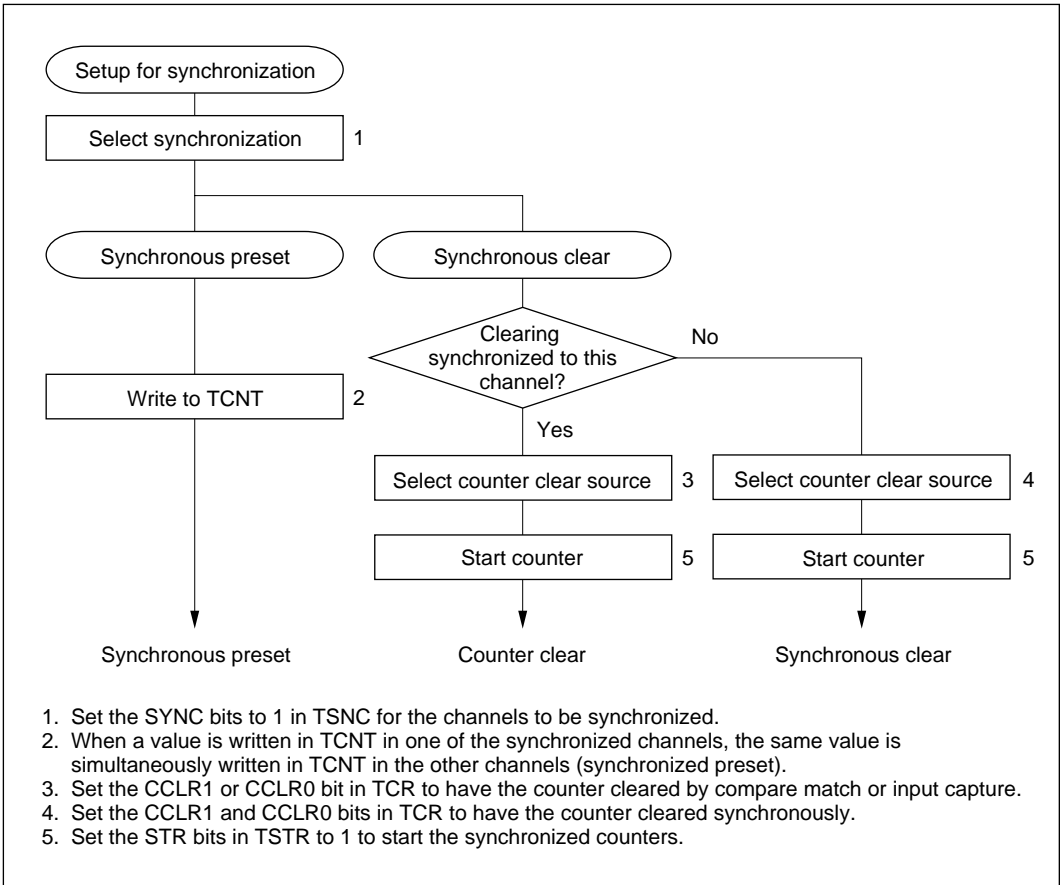

Figure 8-26 Setup Procedure for Synchronization (Example)

Example of Synchronization: Figure 8-27 shows an example of synchronization. Channels 0, 1, and 2 are synchronized, and are set to operate in PWM mode. Channel 0 is set for counter clearing by compare match with GRB0. Channels 1 and 2 are set for synchronous counter clearing. The timer counters in channels 0, 1, and 2 are synchronously preset, and are synchronously cleared by compare match with GRB0. A three-phase PWM waveform is output from pins TIOCA₀, TIOCA₁, and TIOCA₂. For further information on PWM mode, see section 8.4.4, PWM Mode.

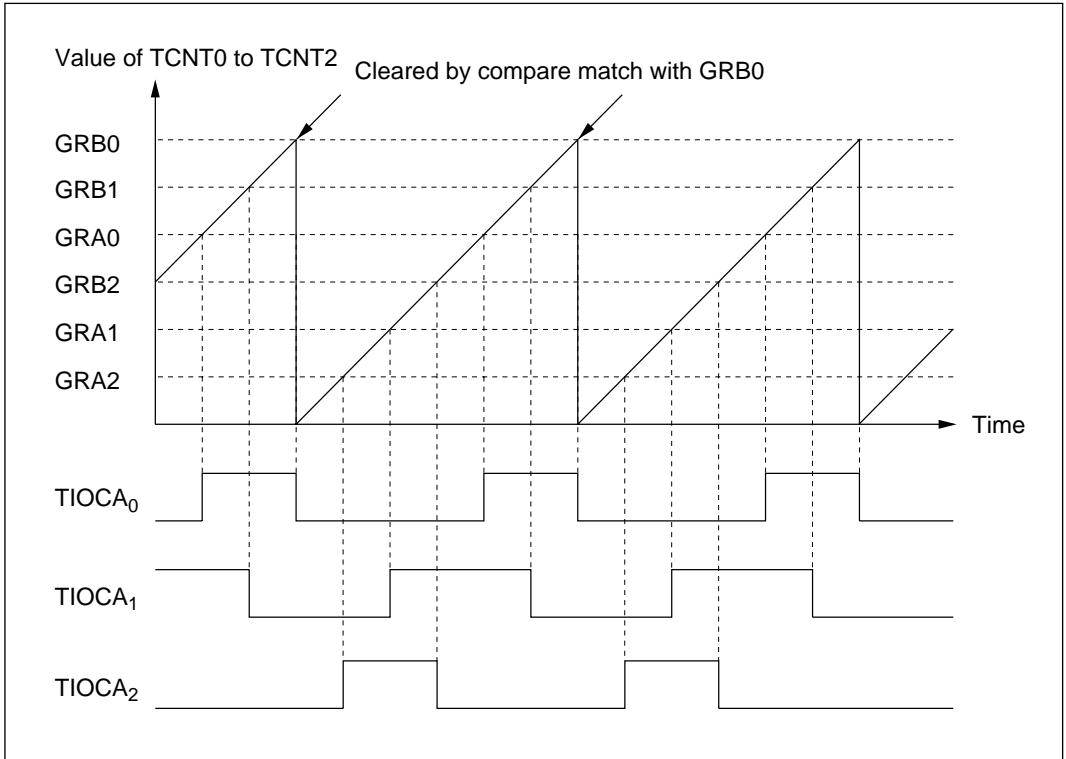

Figure 8-27 Synchronization (Example)

8.4.4 PWM Mode

In PWM mode GRA and GRB are paired and a PWM waveform is output from the TIOCA pin. GRA specifies the time at which the PWM output changes to 1. GRB specifies the time at which the PWM output changes to 0. If either GRA or GRB is selected as the counter clear source, a PWM waveform with a duty cycle from 0% to 100% is output at the TIOCA pin. PWM mode can be selected in all channels (0 to 4).

Table 8-4 summarizes the PWM output pins and corresponding registers. If the same value is set in GRA and GRB, the output does not change when compare match occurs.

Table 8-4 PWM Output Pins and Registers

Channel	Output Pin	1 Output	0 Output
0	TIOCA ₀	GRA0	GRB0
1	TIOCA ₁	GRA1	GRB1
2	TIOCA ₂	GRA2	GRB2
3	TIOCA ₃	GRA3	GRB3
4	TIOCA ₄	GRA4	GRB4

Sample Setup Procedure for PWM Mode: Figure 8-28 shows a sample procedure for setting up PWM mode.

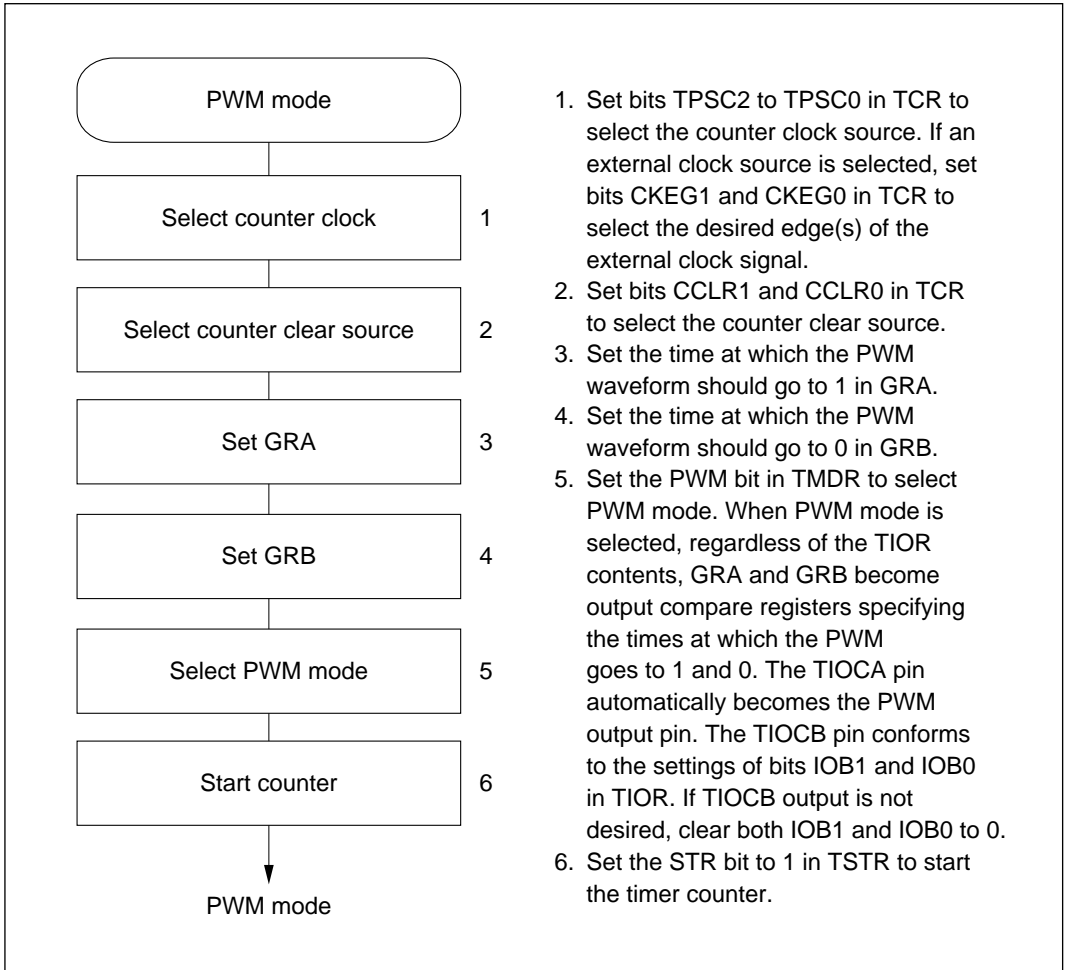

Figure 8-28 Setup Procedure for PWM Mode (Example)

Examples of PWM Mode: Figure 8-29 shows examples of operation in PWM mode. The PWM waveform is output from the TIOCA pin. The output goes to 1 at compare match with GRA, and to 0 at compare match with GRB.

In the examples shown, TCNT is cleared by compare match with GRA or GRB. Synchronized operation and free-running counting are also possible.

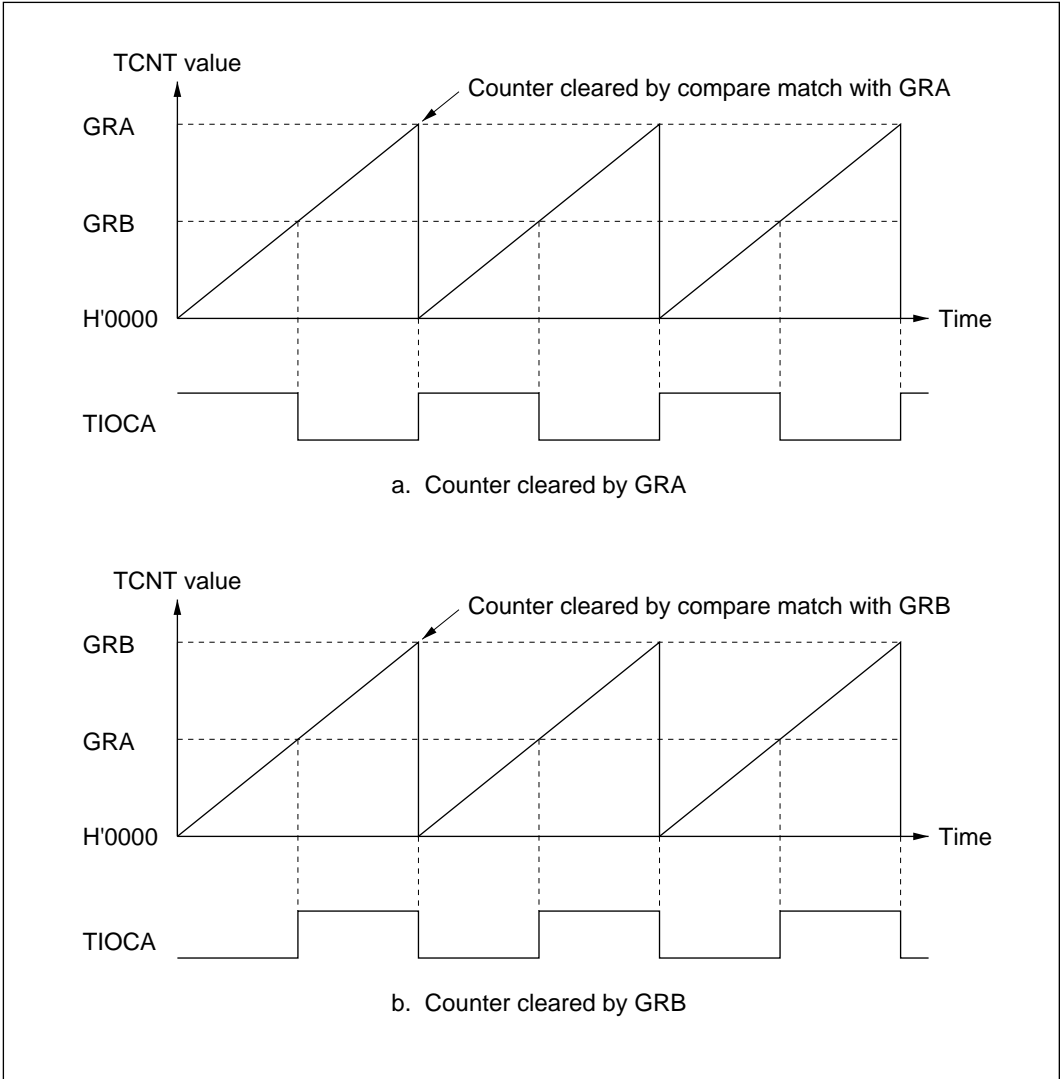

Figure 8-29 PWM Mode (Example 1)

Figure 8-30 shows examples of the output of PWM waveforms with duty cycles of 0% and 100%. If the counter is cleared by compare match with GRB, and GRA is set to a higher value than GRB, the duty cycle is 0%. If the counter is cleared by compare match with GRA, and GRB is set to a higher value than GRA, the duty cycle is 100%.

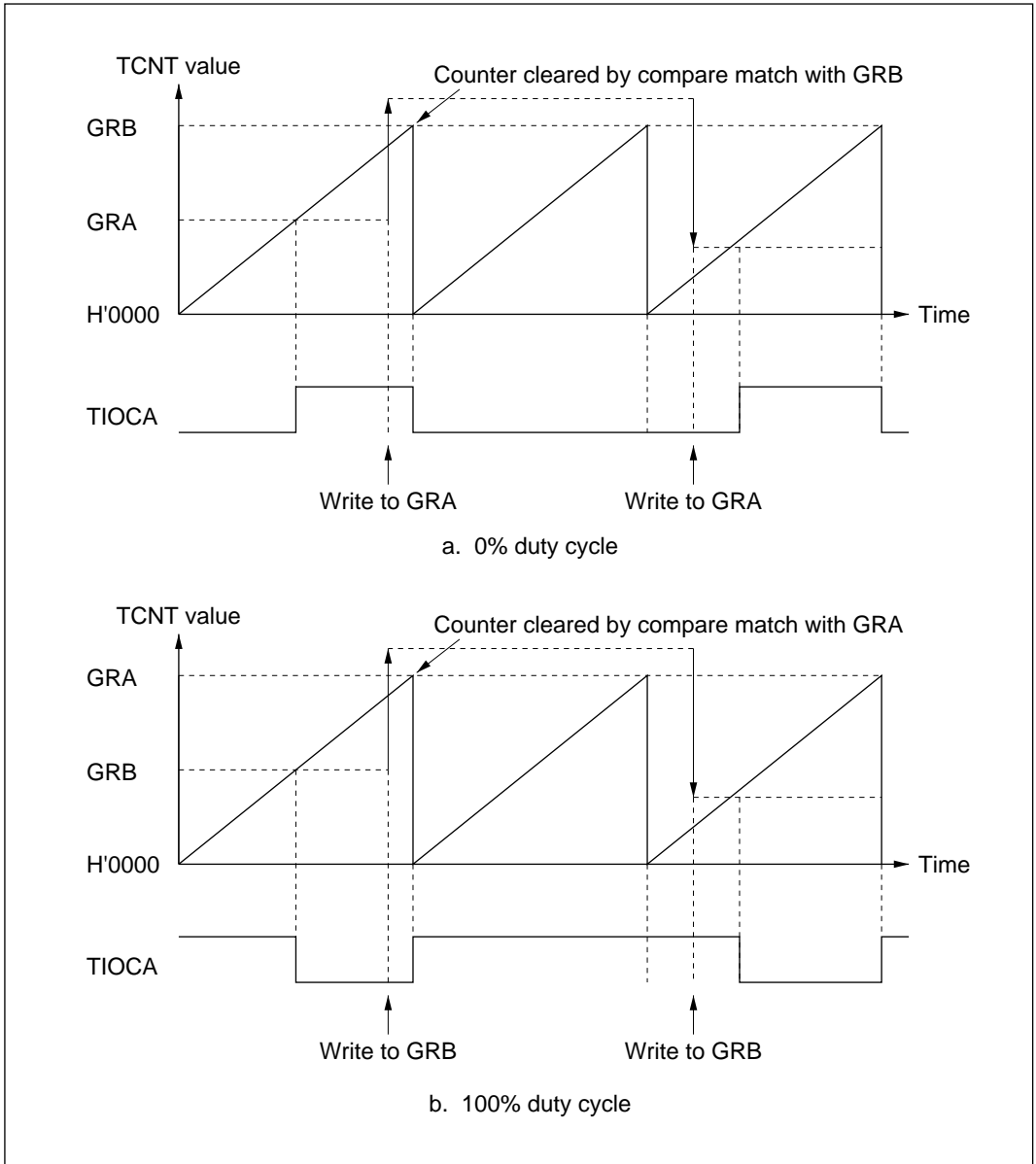

Figure 8-30 PWM Mode (Example 2)

8.4.5 Reset-Synchronized PWM Mode

In reset-synchronized PWM mode channels 3 and 4 are combined to produce three pairs of complementary PWM waveforms, all having one waveform transition point in common.

When reset-synchronized PWM mode is selected TIOCA₃, TIOCB₃, TIOCA₄, TOCXA₄, TIOCB₄, and TOCXB₄ automatically become PWM output pins, and TCNT3 functions as an up-counter.

Table 8-5 lists the PWM output pins. Table 8-6 summarizes the register settings.

Table 8-5 Output Pins in Reset-Synchronized PWM Mode

Channel	Output Pin	Description
3	TIOCA ₃	PWM output 1
	TIOCB ₃	PWM output 1' (complementary waveform to PWM output 1)
4	TIOCA ₄	PWM output 2
	TOCXA ₄	PWM output 2' (complementary waveform to PWM output 2)
	TIOCB ₄	PWM output 3
	TOCXB ₄	PWM output 3' (complementary waveform to PWM output 3)

Table 8-6 Register Settings in Reset-Synchronized PWM Mode

Register	Setting
TCNT3	Initially set to H'0000
TCNT4	Not used (operates independently)
GRA3	Specifies the count period of TCNT3
GRB3	Specifies a transition point of PWM waveforms output from TIOCA ₃ and TIOCB ₃
GRA4	Specifies a transition point of PWM waveforms output from TIOCA ₄ and TOCXA ₄
GRB4	Specifies a transition point of PWM waveforms output from TIOCB ₄ and TOCXB ₄

Sample Setup Procedure for Reset-Synchronized PWM Mode: Figure 8-31 shows a sample procedure for setting up reset-synchronized PWM mode.

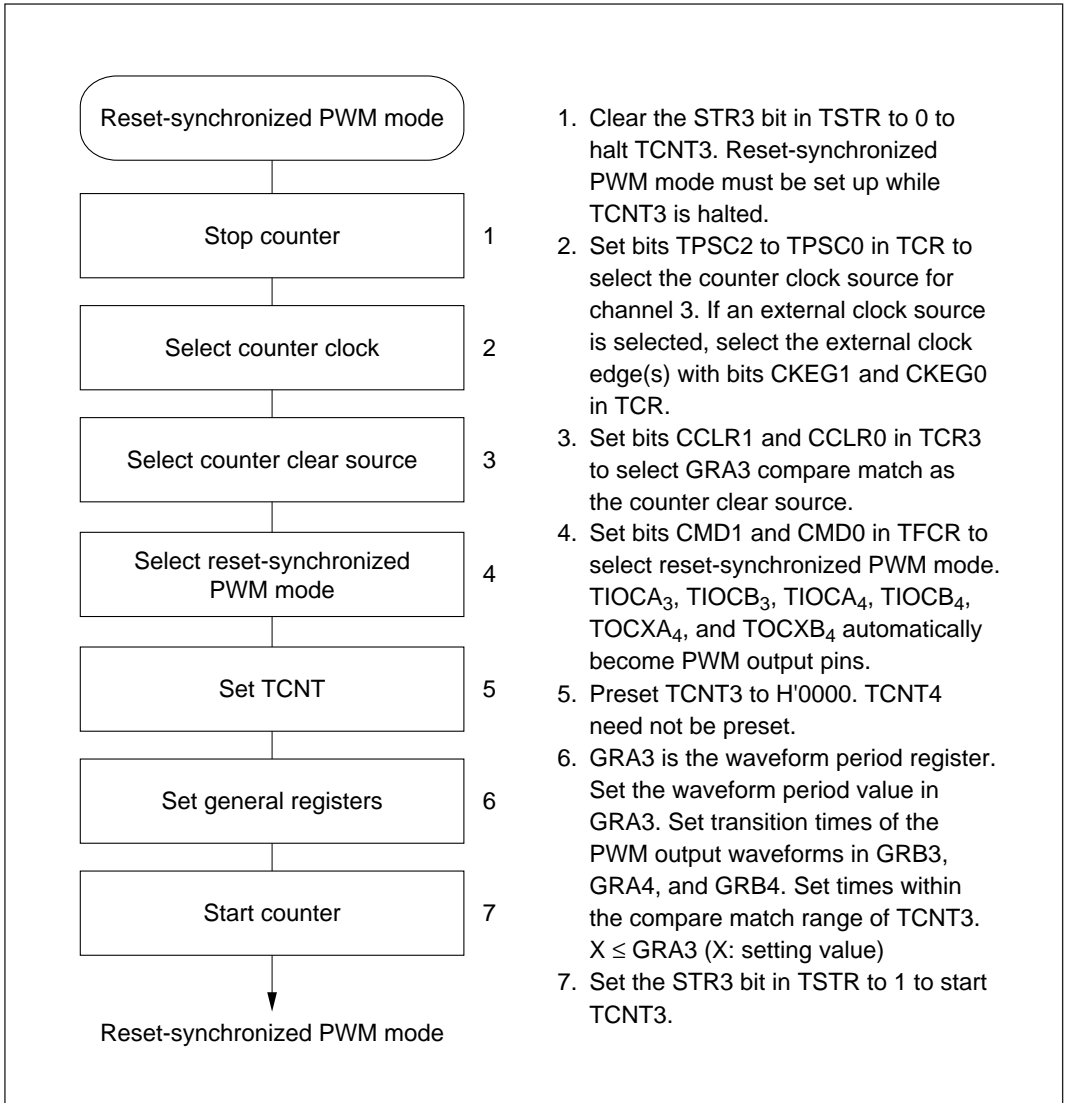

Figure 8-31 Setup Procedure for Reset-Synchronized PWM Mode (Example)

Example of Reset-Synchronized PWM Mode: Figure 8-32 shows an example of operation in reset-synchronized PWM mode. TCNT3 operates as an up-counter in this mode. TCNT4 operates independently, detached from GRA4 and GRB4. When TCNT3 matches GRA3, TCNT3 is cleared and resumes counting from H'0000. The PWM outputs toggle at compare match with GRB3, GRA4, GRB4, and TCNT3 respectively, and all toggle when the counter is cleared.

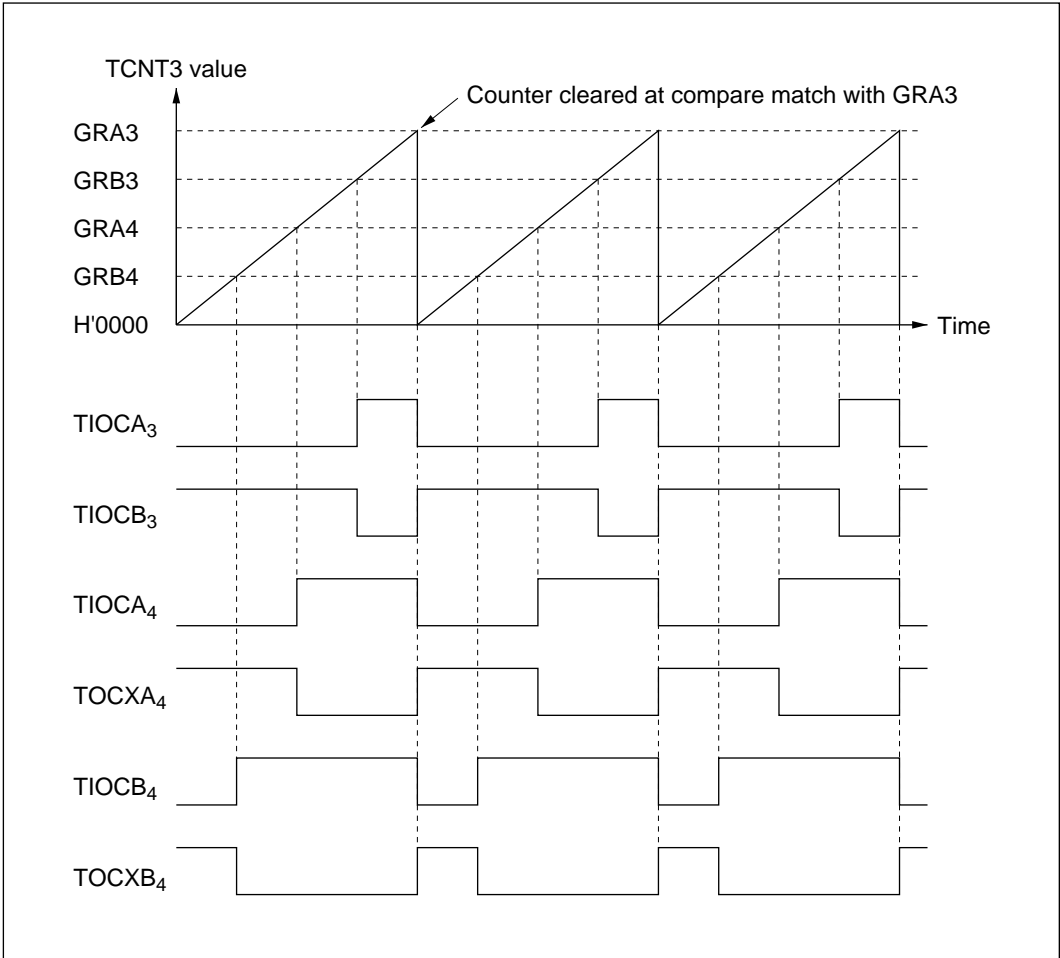

Figure 8-32 Operation in Reset-Synchronized PWM Mode (Example)
(when OLS3 = OLS4 = 1)

For the settings and operation when reset-synchronized PWM mode and buffer mode are both selected, see section 8.4.8, Buffering.

8.4.6 Complementary PWM Mode

In complementary PWM mode channels 3 and 4 are combined to output three pairs of complementary, non-overlapping PWM waveforms.

When complementary PWM mode is selected TIOCA₃, TIOCB₃, TIOCA₄, TOCXA₄, TIOCB₄, and TOCXB₄ automatically become PWM output pins, and TCNT3 and TCNT4 function as up/down-counters.

Table 8-7 lists the PWM output pins. Table 8-8 summarizes the register settings.

Table 8-7 Output Pins in Complementary PWM Mode

Channel	Output Pin	Description
3	TIOCA ₃	PWM output 1
	TIOCB ₃	PWM output 1' (non-overlapping complementary waveform to PWM output 1)
4	TIOCA ₄	PWM output 2
	TOCXA ₄	PWM output 2' (non-overlapping complementary waveform to PWM output 2)
	TIOCB ₄	PWM output 3
	TOCXB ₄	PWM output 3' (non-overlapping complementary waveform to PWM output 3)

Table 8-8 Register Settings in Complementary PWM Mode

Register	Setting
TCNT3	Initially specifies the non-overlap margin (difference to TCNT4)
TCNT4	Initially set to H'0000
GRA3	Specifies the upper limit value of TCNT3 minus 1
GRB3	Specifies a transition point of PWM waveforms output from TIOCA ₃ and TIOCB ₃
GRA4	Specifies a transition point of PWM waveforms output from TIOCA ₄ and TOCXA ₄
GRB4	Specifies a transition point of PWM waveforms output from TIOCB ₄ and TOCXB ₄

Setup Procedure for Complementary PWM Mode: Figure 8-33 shows a sample procedure for setting up complementary PWM mode.

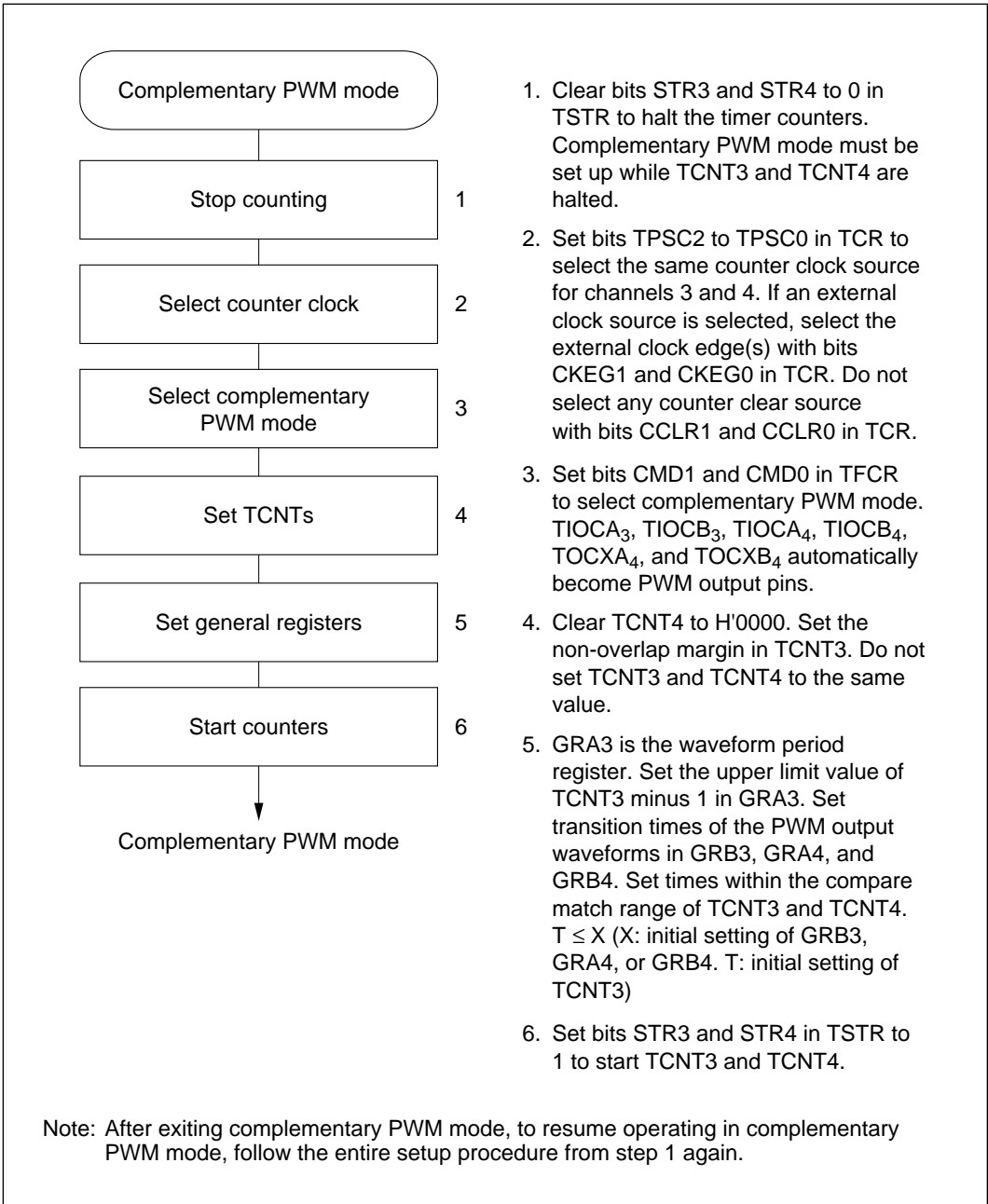

Figure 8-33 Setup Procedure for Complementary PWM Mode (Example)

Clearing Complementary PWM Mode: Figure 8-34 shows a sample procedure for clearing complementary PWM mode.

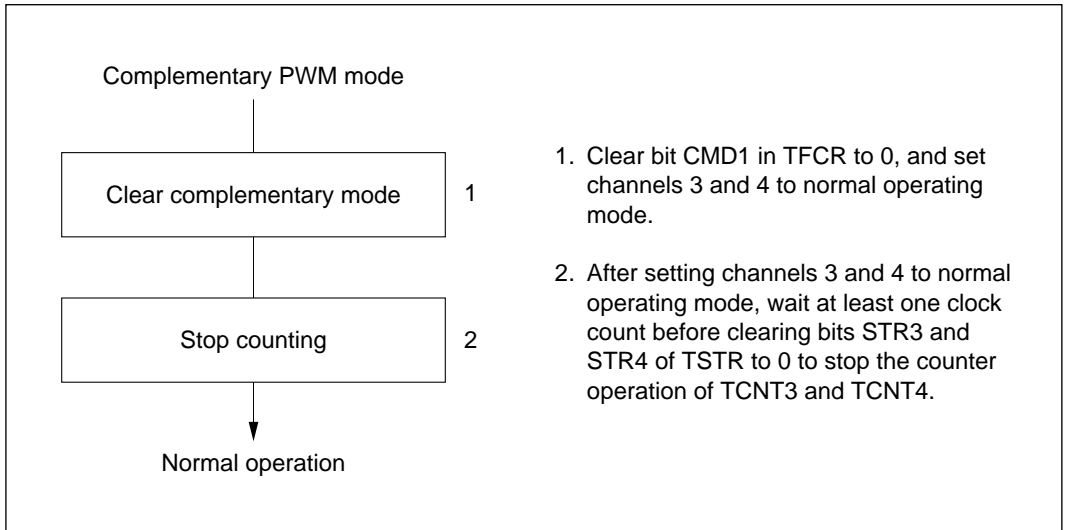

Figure 8-34 Clearing Procedure for Complementary PWM Mode (Example)

Examples of Complementary PWM Mode: Figure 8-35 shows an example of operation in complementary PWM mode. TCNT3 and TCNT4 operate as up/down-counters, counting down from compare match between TCNT3 and GRA3 and counting up from the point at which TCNT4 underflows. During each up-and-down counting cycle, PWM waveforms are generated by compare match with general registers GRB3, GRA4, and GRB4. Since TCNT3 is initially set to a higher value than TCNT4, compare match events occur in the sequence TCNT3, TCNT4, TCNT4, TCNT3.

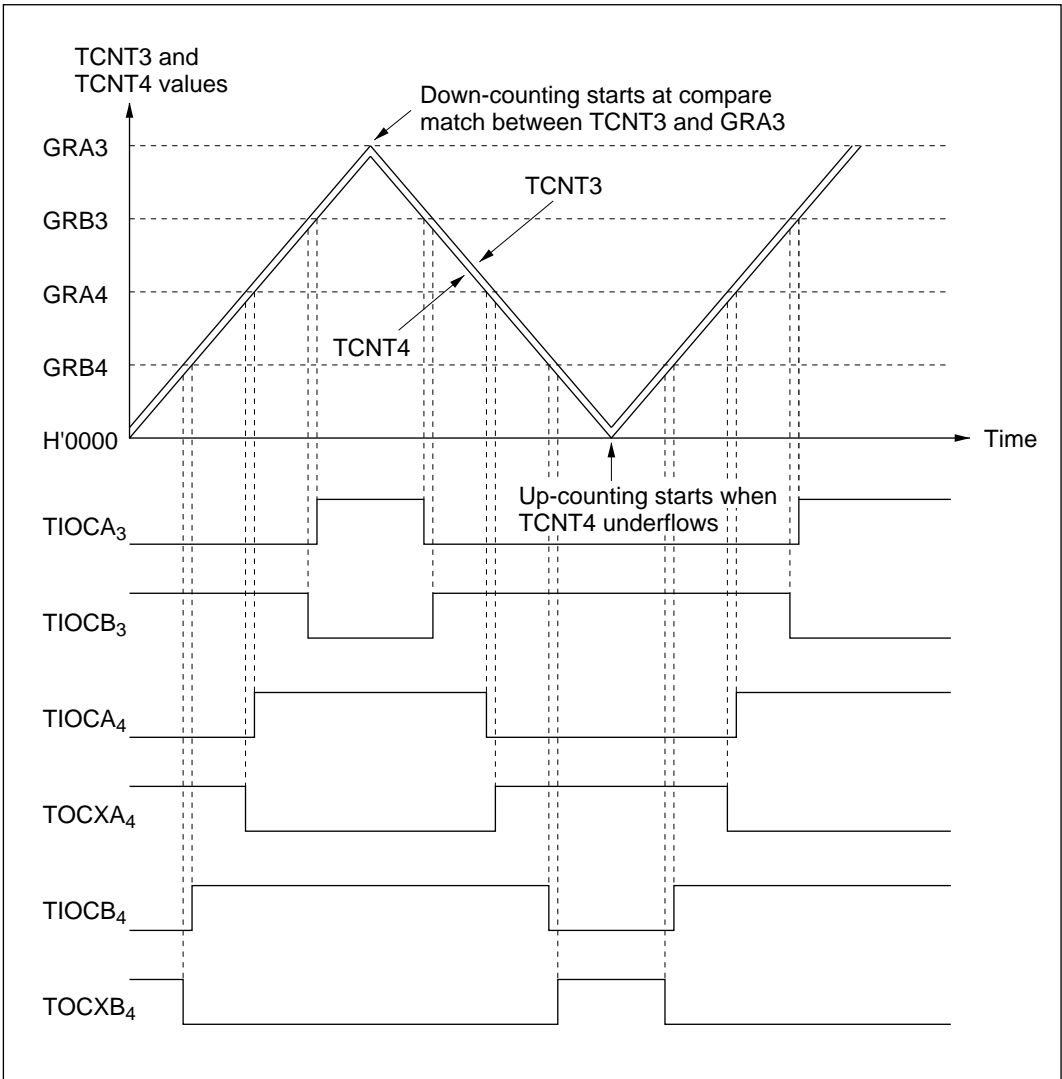

Figure 8-35 Operation in Complementary PWM Mode (Example 1)
(when OLS3 = OLS4 = 1)

Figure 8-36 shows examples of waveforms with 0% and 100% duty cycles (in one phase) in complementary PWM mode. In this example the outputs change at compare match with GRB3, so waveforms with duty cycles of 0% or 100% can be output by setting GRB3 to a value larger than GRA3. The duty cycle can be changed easily during operation by use of the buffer registers. For further information see section 8.4.8, Buffering.

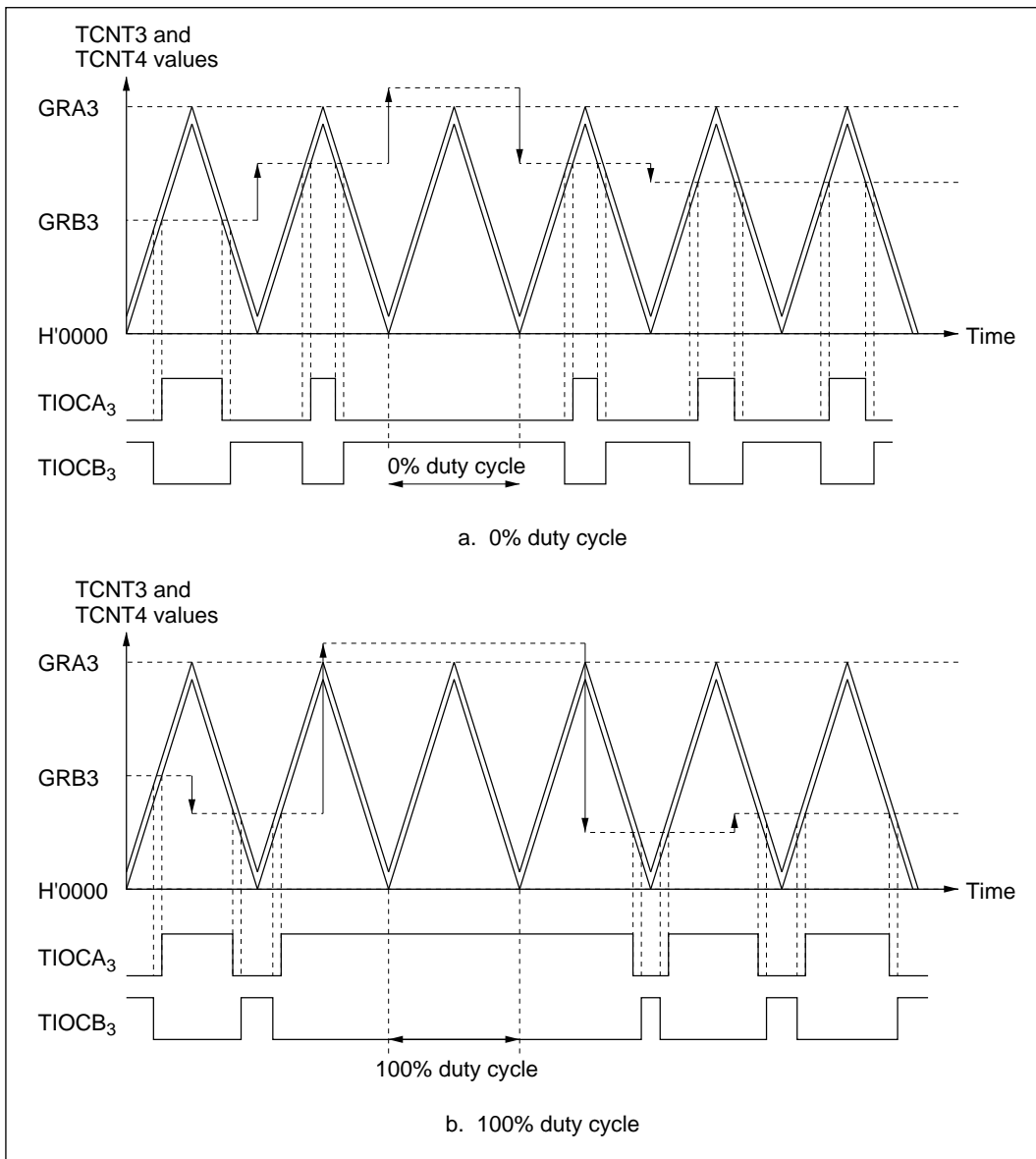

Figure 8-36 Operation in Complementary PWM Mode (Example 2)
 (when OLS3 = OLS4 = 1)

In complementary PWM mode, TCNT3 and TCNT4 overshoot and undershoot at the transitions between up-counting and down-counting. The setting conditions for the IMFA bit in channel 3 and the OVF bit in channel 4 differ from the usual conditions. In buffered operation the buffer transfer conditions also differ. Timing diagrams are shown in figures 8-37 and 8-38.

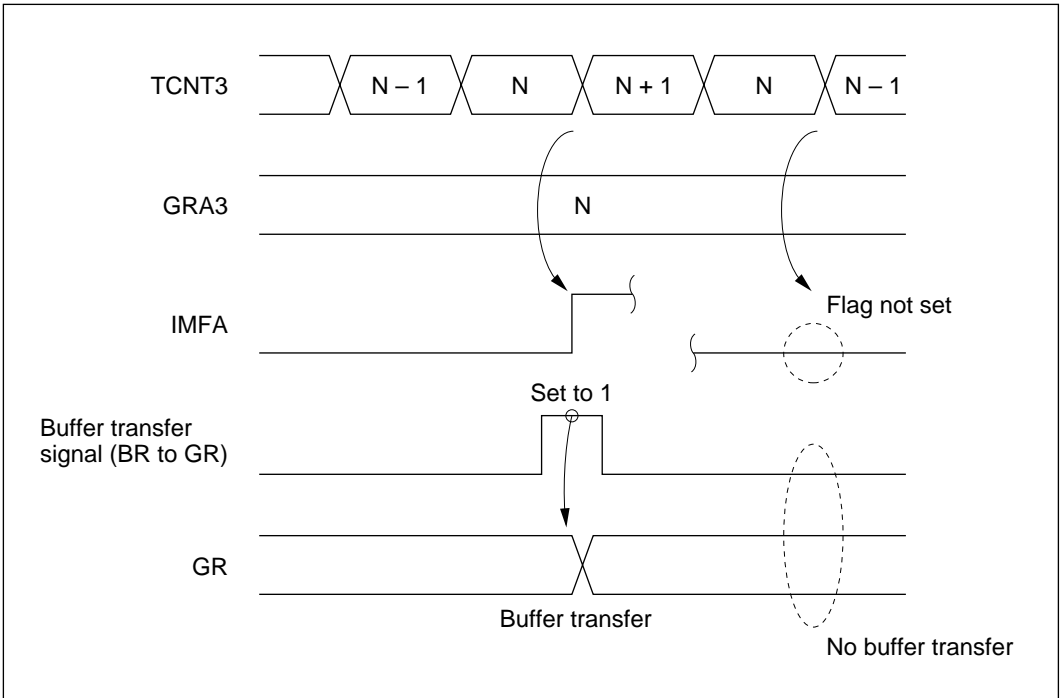

Figure 8-37 Overshoot Timing

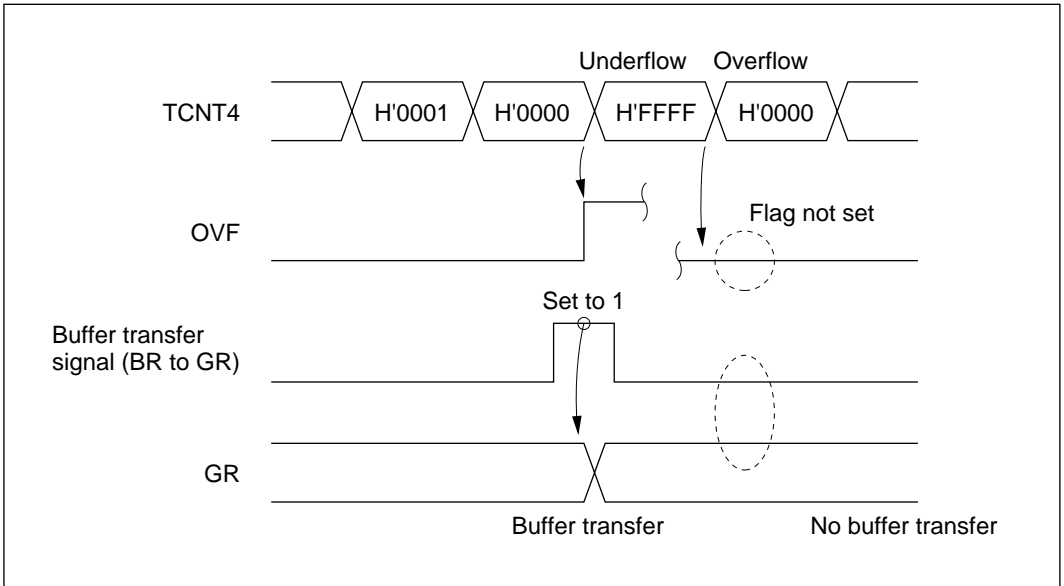

Figure 8-38 Undershoot Timing

In channel 3, IMFA is set to 1 only during up-counting. In channel 4, OVF is set to 1 only when an underflow occurs. When buffering is selected, buffer register contents are transferred to the general register at compare match A3 during up-counting, and when TCNT4 underflows.

General Register Settings in Complementary PWM Mode: When setting up general registers for complementary PWM mode or changing their settings during operation, note the following points.

- Initial settings

Do not set values from H'0000 to T – 1 (where T is the initial value of TCNT3). After the counters start and the first compare match A3 event has occurred, however, settings in this range also become possible.

- Changing settings

Use the buffer registers. Correct waveform output may not be obtained if a general register is written to directly.

- Cautions on changes of general register settings

Figure 8-39 shows six correct examples and one incorrect example.

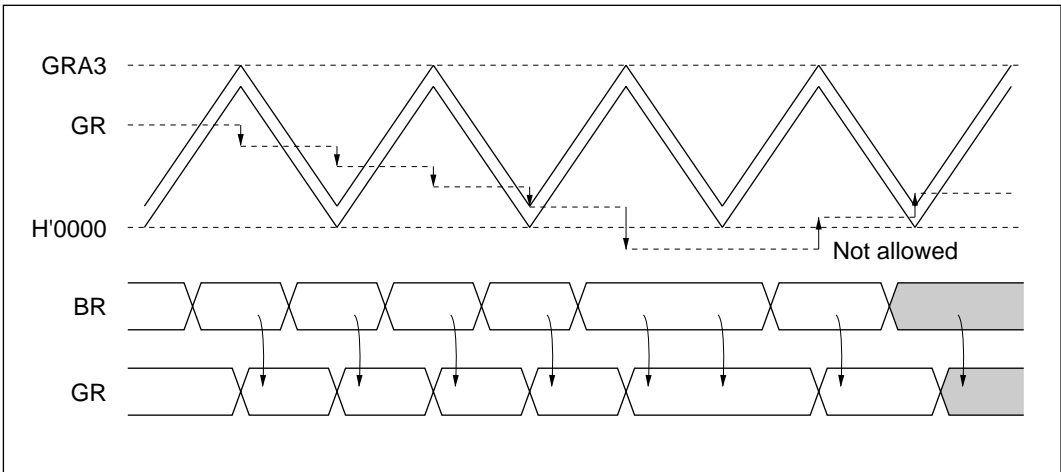

Figure 8-39 Changing a General Register Setting by Buffer Transfer (Example 1)

— Buffer transfer at transition from up-counting to down-counting

If the general register value is in the range from $\text{GRA3} - T + 1$ to GRA3 , do not transfer a buffer register value outside this range. Conversely, if the general register value is outside this range, do not transfer a value within this range. See figure 8-40.

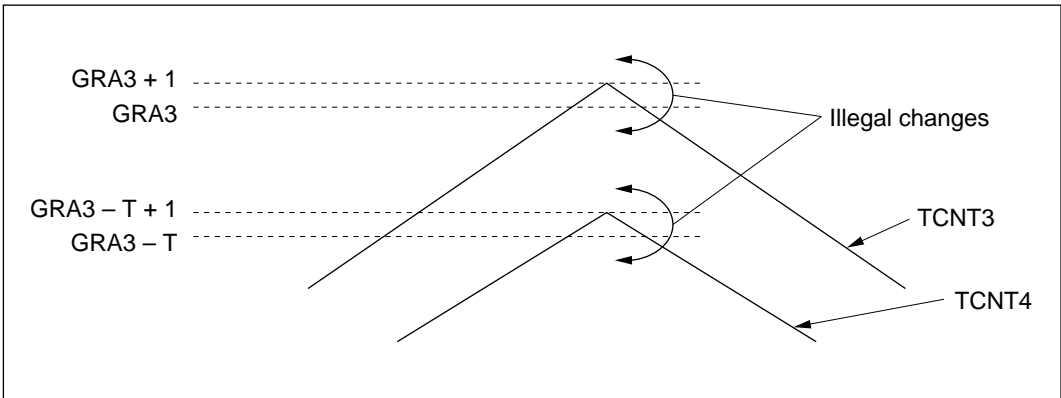

Figure 8-40 Changing a General Register Setting by Buffer Transfer (Caution 1)

— Buffer transfer at transition from down-counting to up-counting

If the general register value is in the range from H'0000 to T - 1, do not transfer a buffer register value outside this range. Conversely, when a general register value is outside this range, do not transfer a value within this range. See figure 8-41.

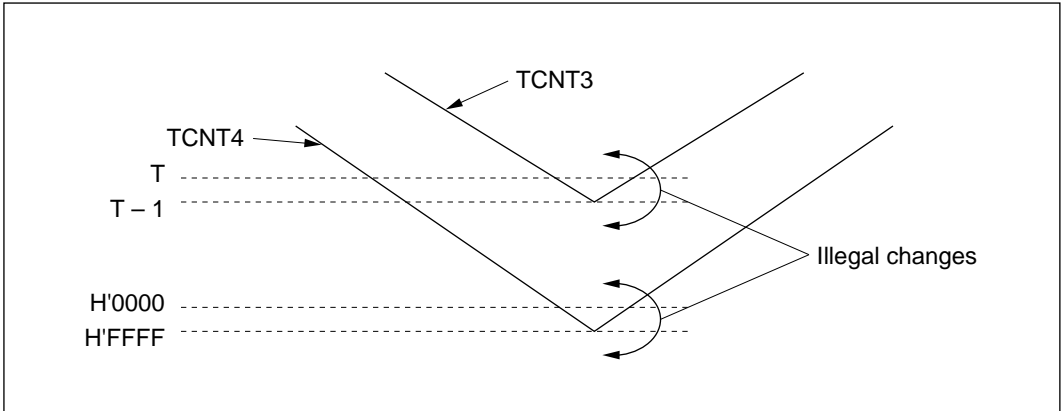

Figure 8-41 Changing a General Register Setting by Buffer Transfer (Caution 2)

— General register settings outside the counting range (H'0000 to GRA3)

Waveforms with a duty cycle of 0% or 100% can be output by setting a general register to a value outside the counting range. When a buffer register is set to a value outside the counting range, then later restored to a value within the counting range, the counting direction (up or down) must be the same both times. See figure 8-42.

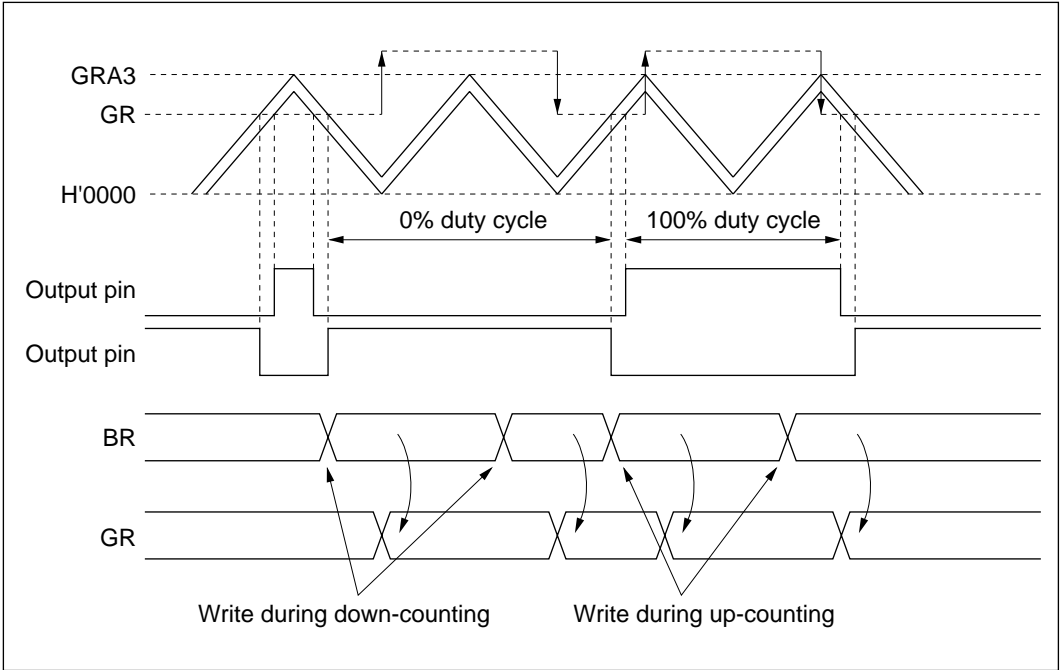

Figure 8-42 Changing a General Register Setting by Buffer Transfer (Example 2)

Settings can be made in this way by detecting GRA3 compare match or TCNT4 underflow before writing to the buffer register.

8.4.7 Phase Counting Mode

In phase counting mode the phase difference between two external clock inputs (at the TCLKA and TCLKB pins) is detected, and TCNT2 counts up or down accordingly.

In phase counting mode, the TCLKA and TCLKB pins automatically function as external clock input pins and TCNT2 becomes an up/down-counter, regardless of the settings of bits TPSC2 to TPSC0, CKEG1, and CKEG0 in TCR2. Settings of bits CCLR1, CCLR0 in TCR2, and settings in TIOR2, TIER2, TSR2, GRA2, and GRB2 are valid. The input capture and output compare functions can be used, and interrupts can be generated.

Phase counting is available only in channel 2.

Sample Setup Procedure for Phase Counting Mode: Figure 8-43 shows a sample procedure for setting up phase counting mode.

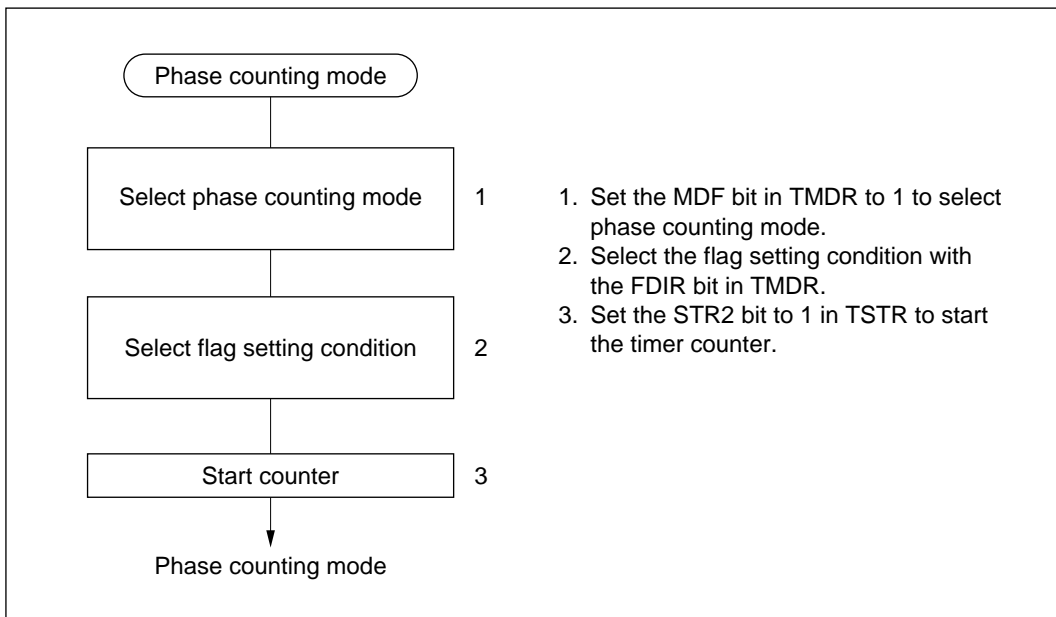

Figure 8-43 Setup Procedure for Phase Counting Mode (Example)

Example of Phase Counting Mode: Figure 8-44 shows an example of operations in phase counting mode. Table 8-9 lists the up-counting and down-counting conditions for TCNT2.

In phase counting mode both the rising and falling edges of TCLKA and TCLKB are counted. The phase difference between TCLKA and TCLKB must be at least 1.5 states, the phase overlap must also be at least 1.5 states, and the pulse width must be at least 2.5 states. See figure 8-45.

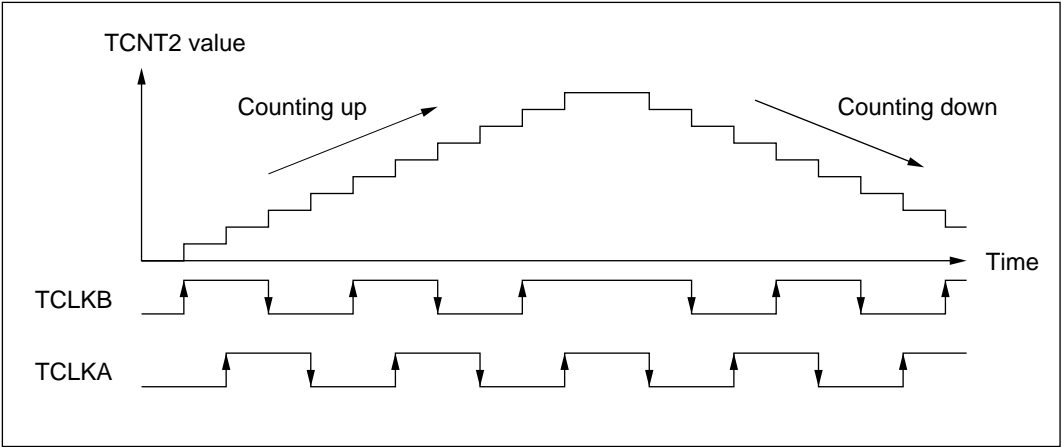

Figure 8-44 Operation in Phase Counting Mode (Example)

Table 8-9 Up/Down Counting Conditions

Counting Direction	Up-Counting				Down-Counting			
TCLKB	↓	High	↓	Low	High	↓	Low	↓
TCLKA	Low	↓	High	↓	↓	Low	↓	High

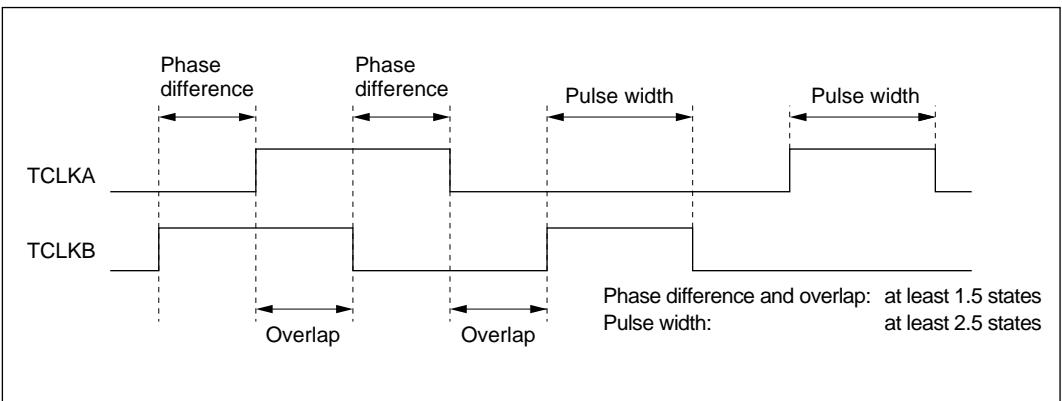

Figure 8-45 Phase Difference, Overlap, and Pulse Width in Phase Counting Mode

8.4.8 Buffering

Buffering operates differently depending on whether a general register is an output compare register or an input capture register, with further differences in reset-synchronized PWM mode and complementary PWM mode. Buffering is available only in channels 3 and 4. Buffering operations under the conditions mentioned above are described next.

- General register used for output compare

The buffer register value is transferred to the general register at compare match. See figure 8-46.

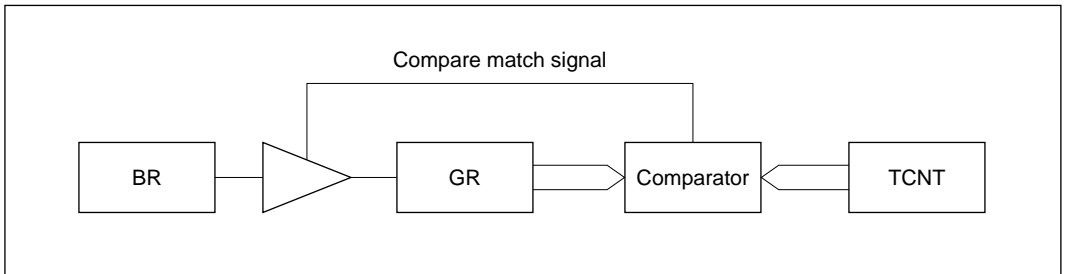

Figure 8-46 Compare Match Buffering

- General register used for input capture

The TCNT value is transferred to the general register at input capture. The previous general register value is transferred to the buffer register.

See figure 8-47.

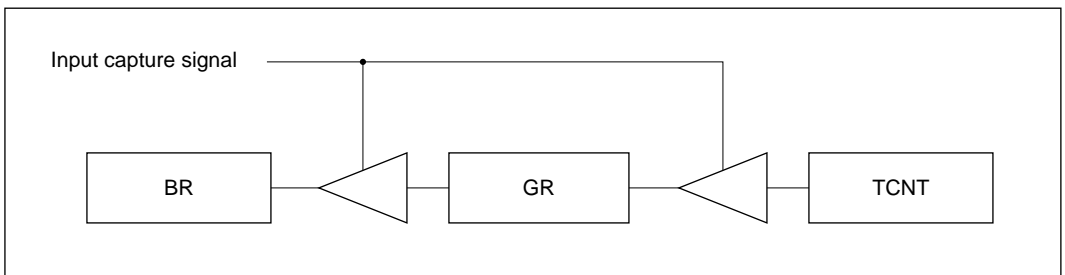

Figure 8-47 Input Capture Buffering

- Complementary PWM mode

The buffer register value is transferred to the general register when TCNT3 and TCNT4 change counting direction. This occurs at the following two times:

- When TCNT3 matches GRA3
- When TCNT4 underflows

- Reset-synchronized PWM mode

The buffer register value is transferred to the general register at compare match A3.

Sample Buffering Setup Procedure: Figure 8-48 shows a sample buffering setup procedure.

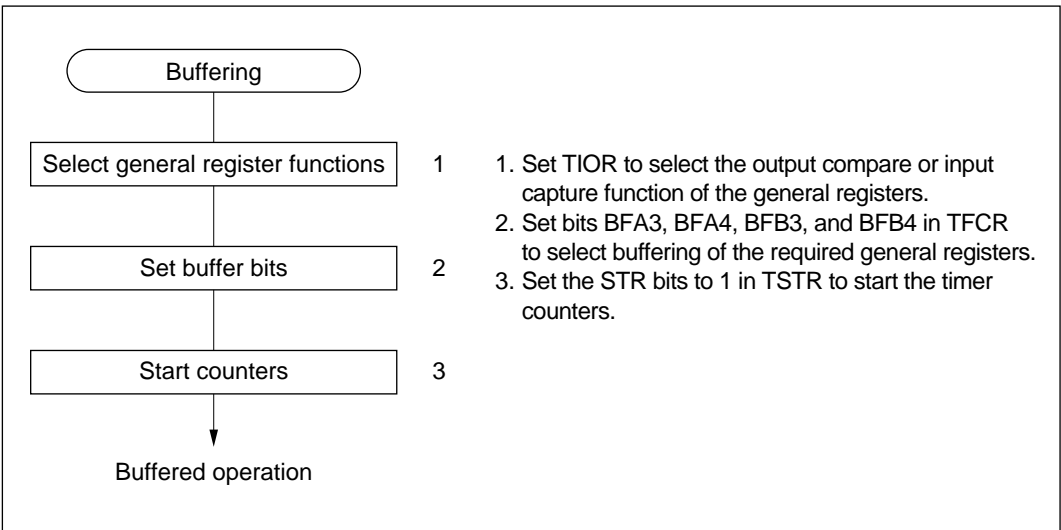

Figure 8-48 Buffering Setup Procedure (Example)

Examples of Buffering: Figure 8-49 shows an example in which GRA is set to function as an output compare register buffered by BRA, TCNT is set to operate as a periodic counter cleared by GRB compare match, and TIOCA and TIOCB are set to toggle at compare match A and B. Because of the buffer setting, when TIOCA toggles at compare match A, the BRA value is simultaneously transferred to GRA. This operation is repeated each time compare match A occurs. Figure 8-50 shows the transfer timing.

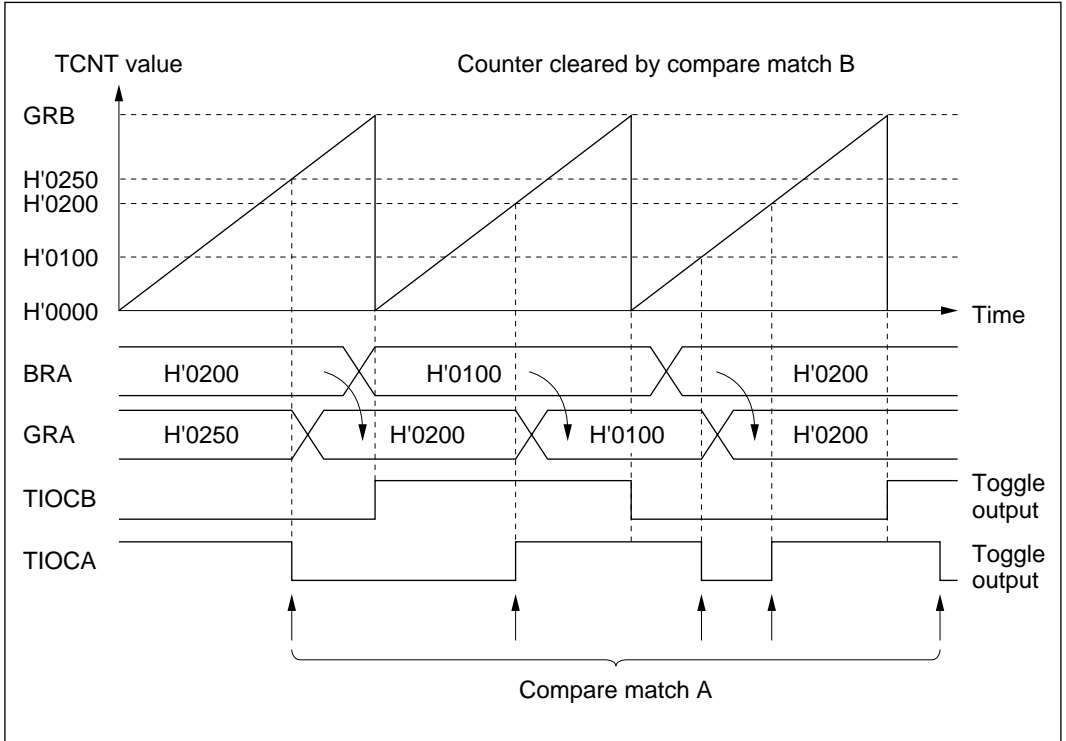

Figure 8-49 Register Buffering (Example 1: Buffering of Output Compare Register)

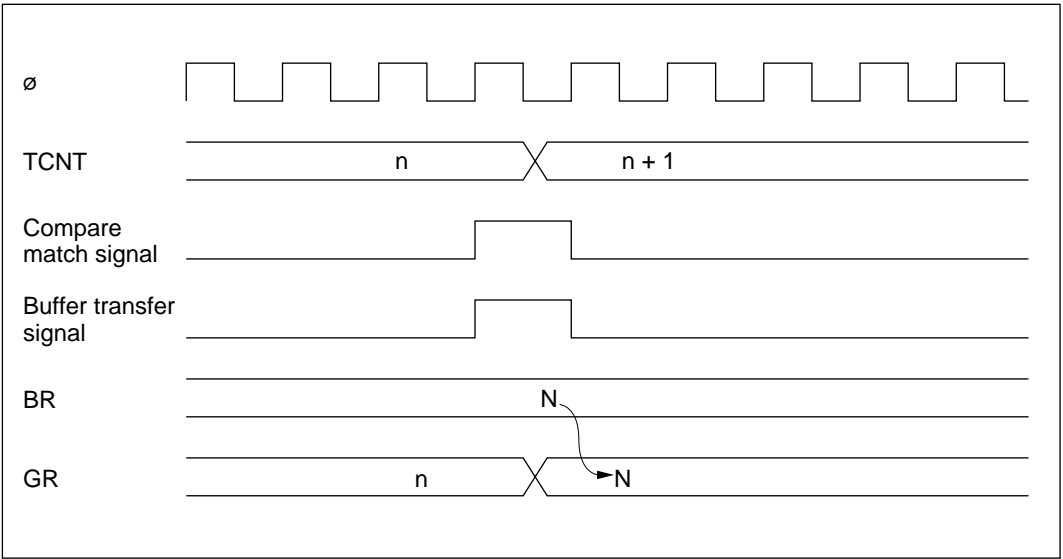

Figure 8-50 Compare Match and Buffer Transfer Timing (Example)

Figure 8-51 shows an example in which GRA is set to function as an input capture register buffered by BRA, and TCNT is cleared by input capture B. The falling edge is selected as the input capture edge at TIOCB. Both edges are selected as input capture edges at TIOCA. Because of the buffer setting, when the TCNT value is captured into GRA at input capture A, the previous GRA value is simultaneously transferred to BRA. Figure 8-52 shows the transfer timing.

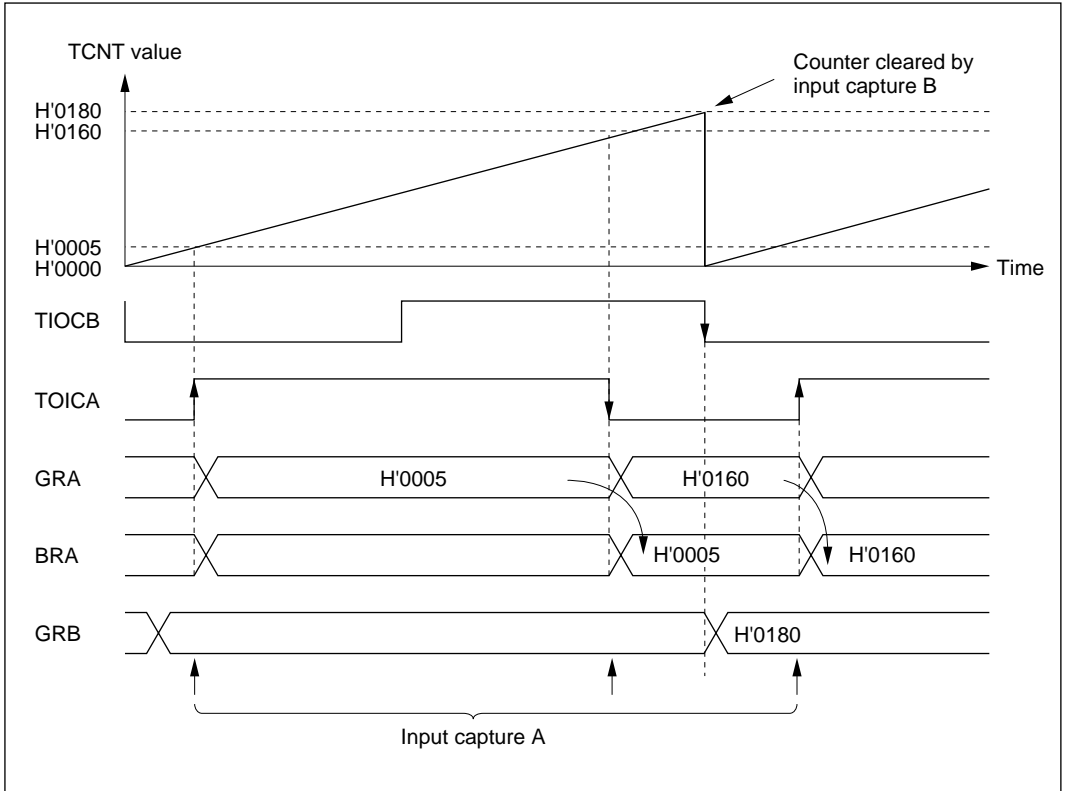

Figure 8-51 Register Buffering (Example 2: Buffering of Input Capture Register)

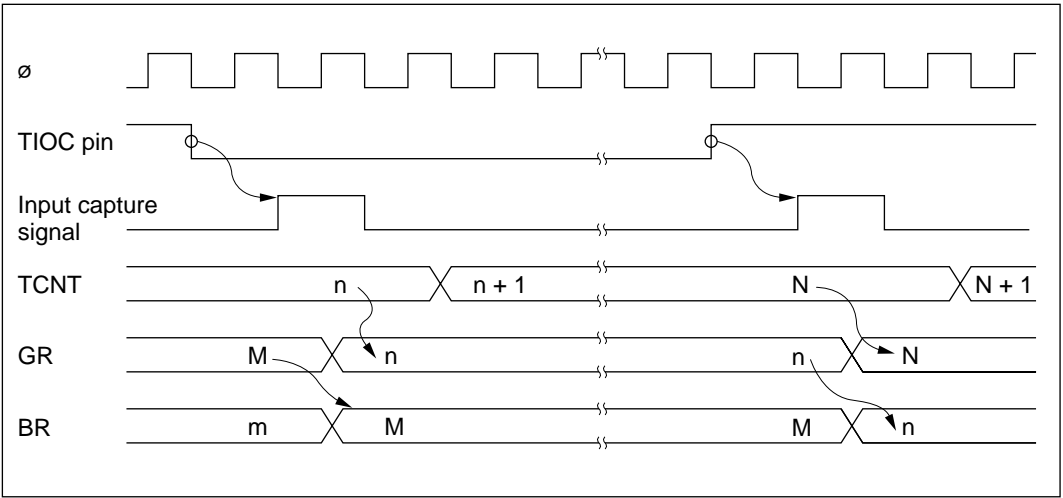

Figure 8-52 Input Capture and Buffer Transfer Timing (Example)

Figure 8-53 shows an example in which GRB3 is buffered by BRB3 in complementary PWM mode. Buffering is used to set GRB3 to a higher value than GRA3, generating a PWM waveform with 0% duty cycle. The BRB3 value is transferred to GRB3 when TCNT3 matches GRA3, and when TCNT4 underflows.

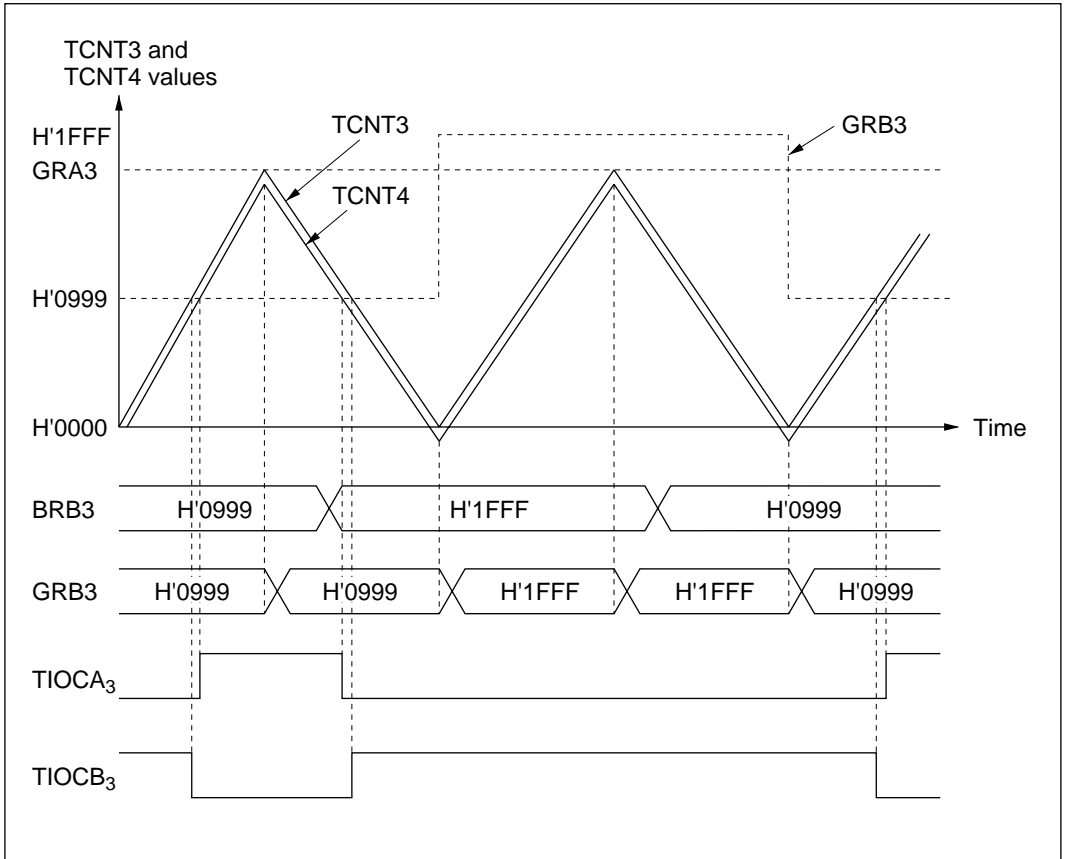

Figure 8-53 Register Buffering (Example 4: Buffering in Complementary PWM Mode)

8.4.9 ITU Output Timing

The ITU outputs from channels 3 and 4 can be disabled by bit settings in TOER or by an external trigger, or inverted by bit settings in TOCR.

Timing of Enabling and Disabling of ITU Output by TOER: In this example an ITU output is disabled by clearing a master enable bit to 0 in TOER. An arbitrary value can be output by appropriate settings of the data register (DR) and data direction register (DDR) of the corresponding input/output port. Figure 8-54 illustrates the timing of the enabling and disabling of ITU output by TOER.

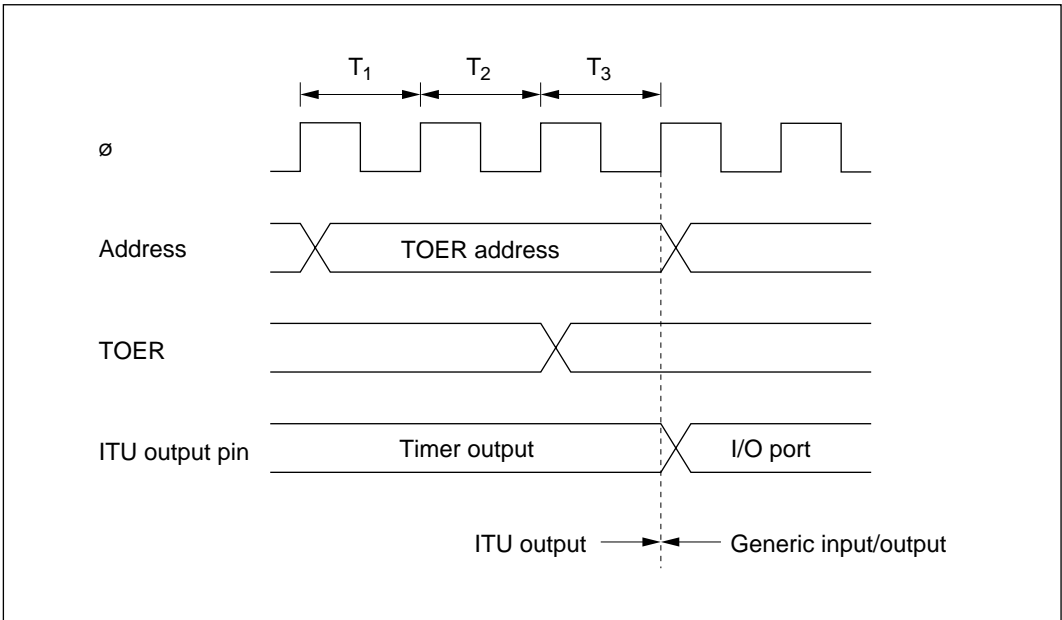

Figure 8-54 Timing of Disabling of ITU Output by Writing to TOER (Example)

Timing of Disabling of ITU Output by External Trigger: If the XTGD bit is cleared to 0 in TOCR in reset-synchronized PWM mode or complementary PWM mode, when an input capture A signal occurs in channel 1, the master enable bits are cleared to 0 in TOER, disabling ITU output. Figure 8-55 shows the timing.

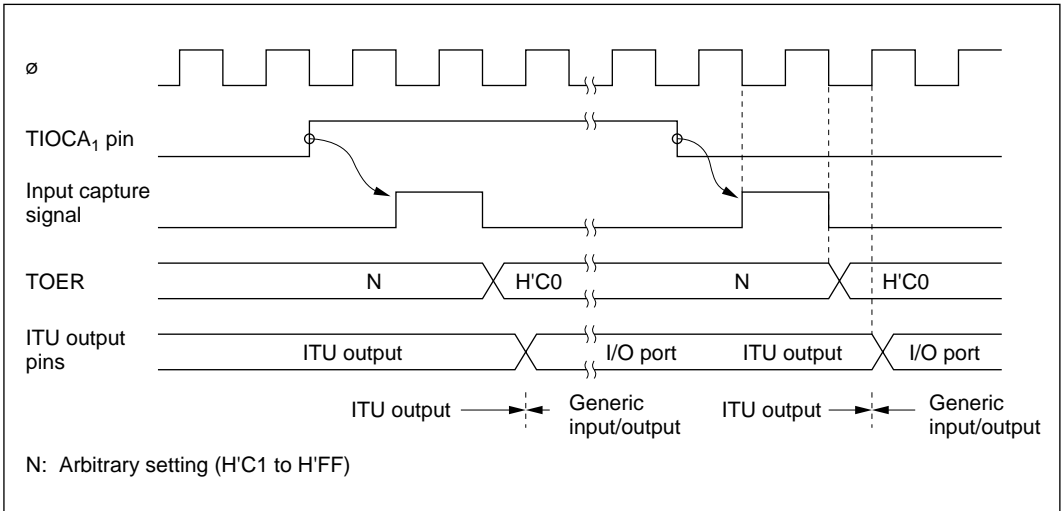

Figure 8-55 Timing of Disabling of ITU Output by External Trigger (Example)

Timing of Output Inversion by TOCR: The output levels in reset-synchronized PWM mode and complementary PWM mode can be inverted by inverting the output level select bits (OLS4 and OLS3) in TOCR. Figure 8-56 shows the timing.

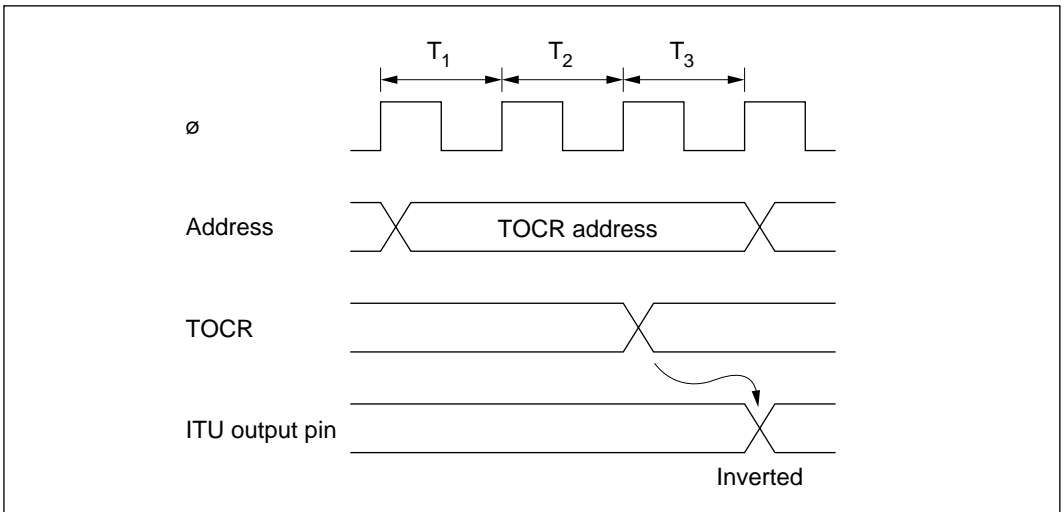

Figure 8-56 Timing of Inverting of ITU Output Level by Writing to TOCR (Example)

8.5 Interrupts

The ITU has two types of interrupts: input capture/compare match interrupts, and overflow interrupts.

8.5.1 Setting of Status Flags

Timing of Setting of IMFA and IMFB at Compare Match: IMFA and IMFB are set to 1 by a compare match signal generated when TCNT matches a general register (GR). The compare match signal is generated in the last state in which the values match (when TCNT is updated from the matching count to the next count). Therefore, when TCNT matches a general register, the compare match signal is not generated until the next timer clock input. Figure 8-57 shows the timing of the setting of IMFA and IMFB.

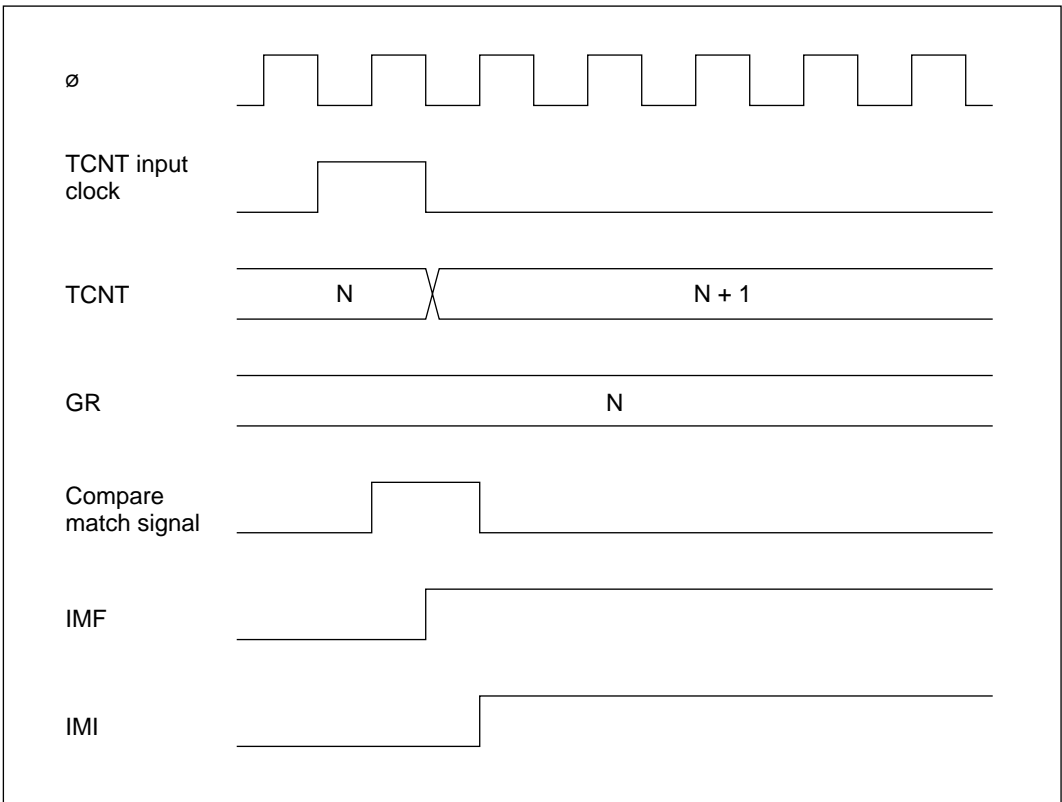

Figure 8-57 Timing of Setting of IMFA and IMFB by Compare Match

Timing of Setting of IMFA and IMFB by Input Capture: IMFA and IMFB are set to 1 by an input capture signal. The TCNT contents are simultaneously transferred to the corresponding general register. Figure 8-58 shows the timing.

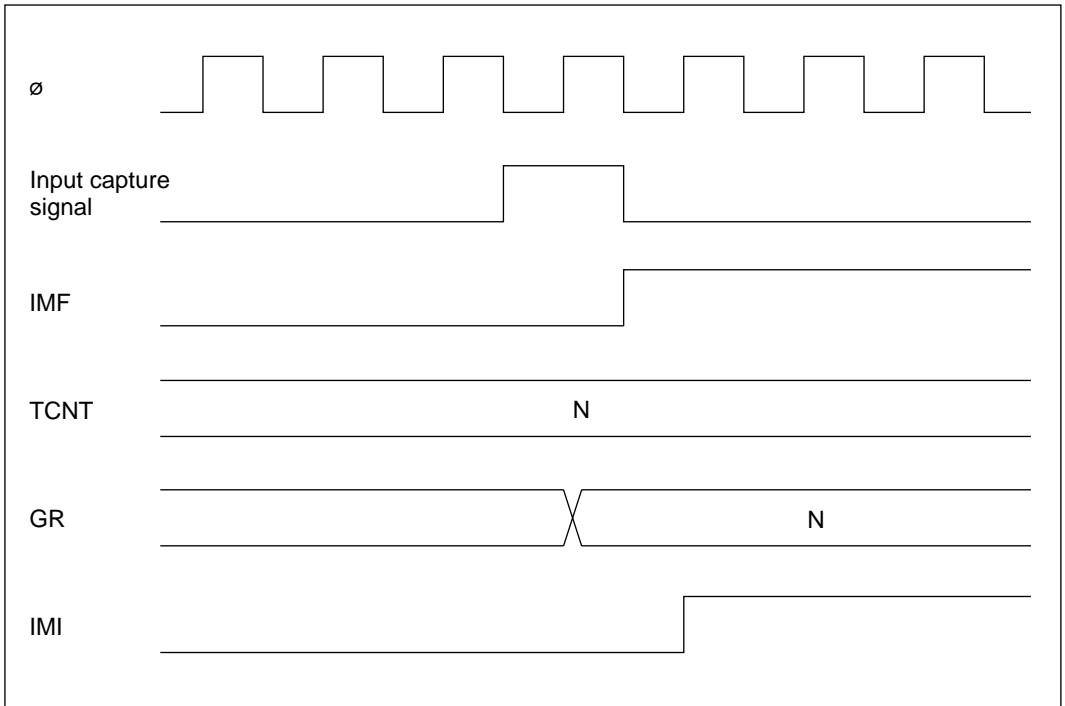

Figure 8-58 Timing of Setting of IMFA and IMFB by Input Capture

Timing of Setting of Overflow Flag (OVF): OVF is set to 1 when TCNT overflows from H'FFFF to H'0000 or underflows from H'0000 to H'FFFF. Figure 8-59 shows the timing.

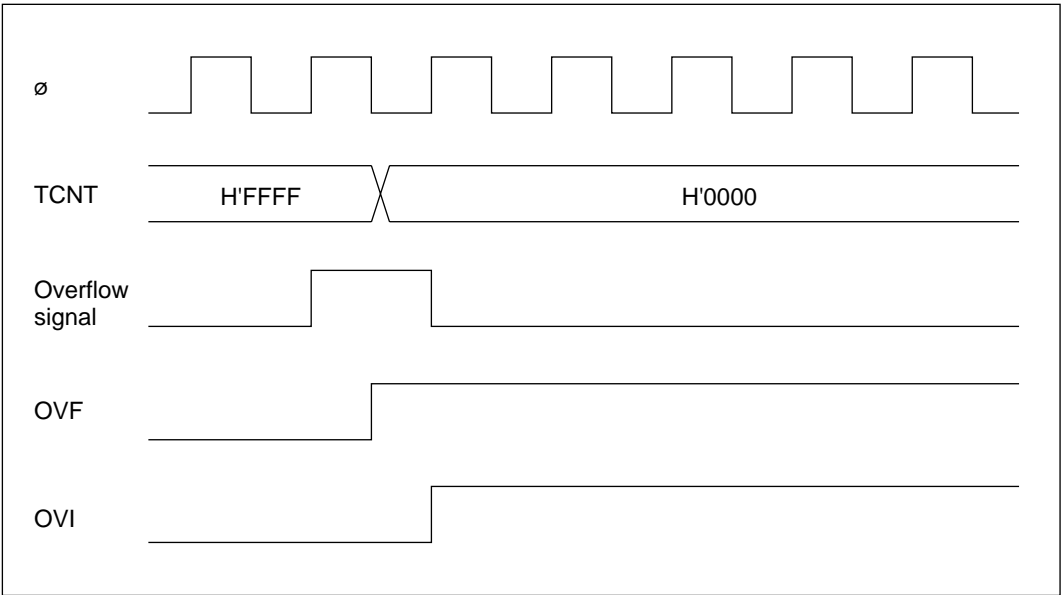

Figure 8-59 Timing of Setting of OVF

8.5.2 Clearing of Status Flags

If the CPU reads a status flag while it is set to 1, then writes 0 in the status flag, the status flag is cleared. Figure 8-60 shows the timing.

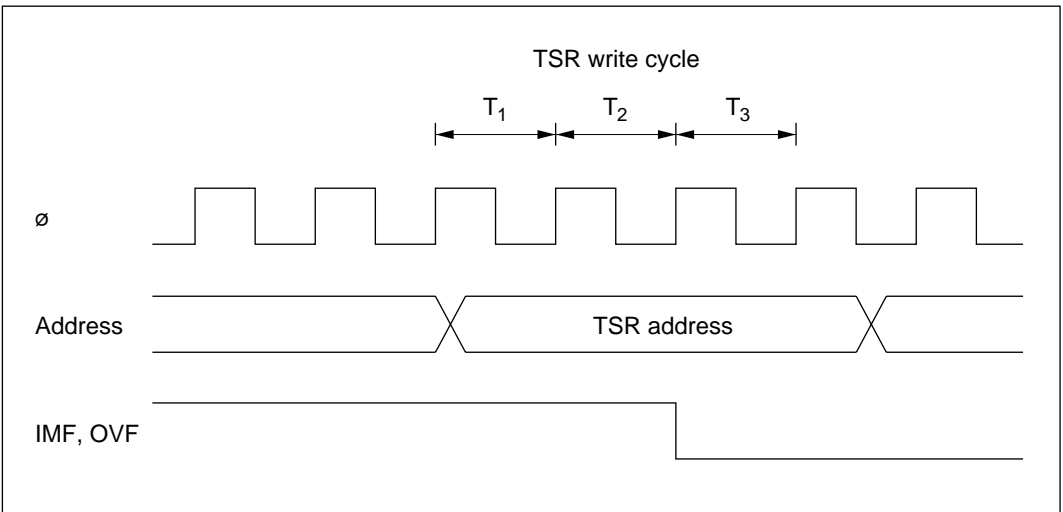

Figure 8-60 Timing of Clearing of Status Flags

8.5.3 Interrupt Sources

Each ITU channel can generate a compare match/input capture A interrupt, a compare match/input capture B interrupt, and an overflow interrupt. In total there are 15 interrupt sources, all independently vectored. An interrupt is requested when the interrupt request flag and interrupt enable bit are both set to 1.

The priority order of the channels can be modified in interrupt priority registers A and B (IPRA and IPRB). For details see section 5, Interrupt Controller.

Table 8-10 lists the interrupt sources.

Table 8-10 ITU Interrupt Sources

Channel	Interrupt Source	Description	Priority*
0	IMIA0	Compare match/input capture A0	
	IMIB0	Compare match/input capture B0	
	OVI0	Overflow 0	
1	IMIA1	Compare match/input capture A1	
	IMIB1	Compare match/input capture B1	
	OVI1	Overflow 1	
2	IMIA2	Compare match/input capture A2	
	IMIB2	Compare match/input capture B2	
	OVI2	Overflow 2	
3	IMIA3	Compare match/input capture A3	
	IMIB3	Compare match/input capture B3	
	OVI3	Overflow 3	
4	IMIA4	Compare match/input capture A4	
	IMIB4	Compare match/input capture B4	
	OVI4	Overflow 4	

Note: *The priority immediately after a reset is indicated. Inter-channel priorities can be changed by settings in IPRA and IPRB.

8.6 Usage Notes

This section describes contention and other matters requiring special attention during ITU operations.

Contention between TCNT Write and Clear: If a counter clear signal occurs in the T_3 state of a TCNT write cycle, clearing of the counter takes priority and the write is not performed. See figure 8-61.

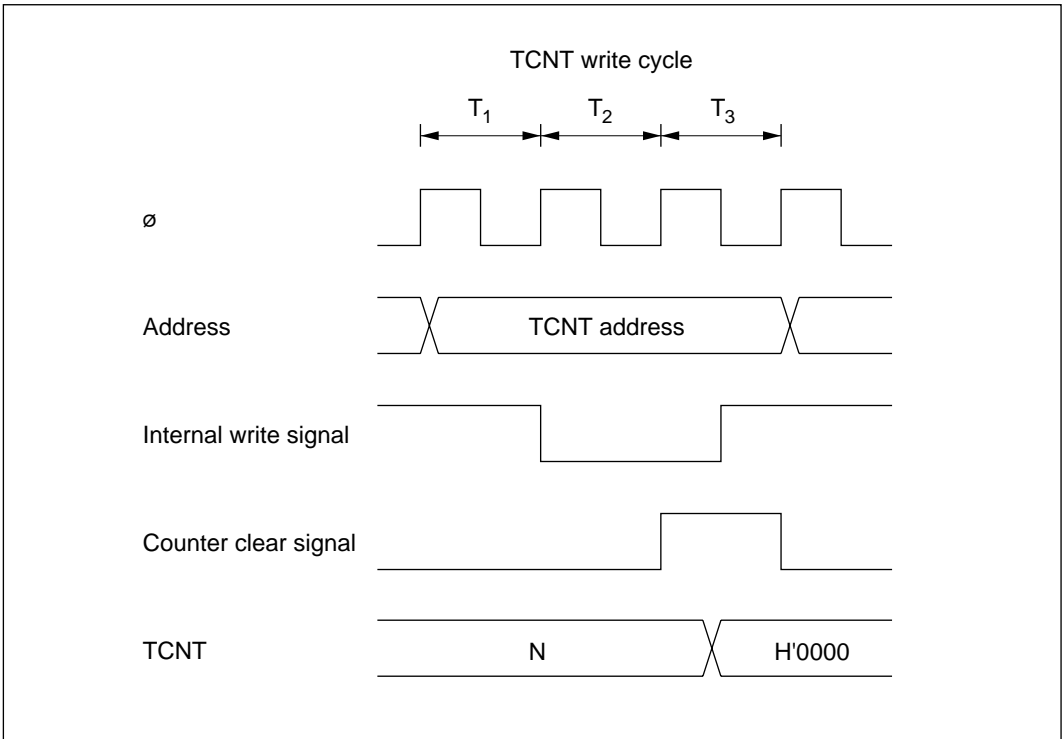

Figure 8-61 Contention between TCNT Write and Clear

Contention between TCNT Word Write and Increment: If an increment pulse occurs in the T_3 state of a TCNT word write cycle, writing takes priority and TCNT is not incremented. See figure 8-62.

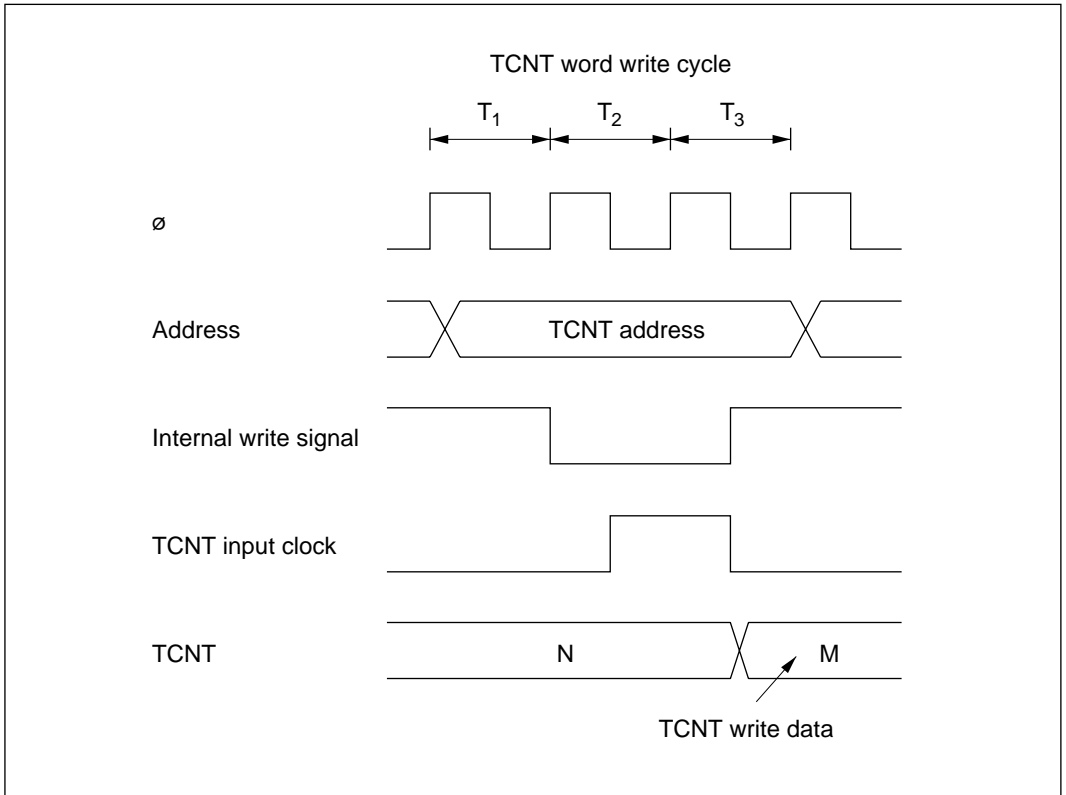

Figure 8-62 Contention between TCNT Word Write and Increment

Contention between TCNT Byte Write and Increment: If an increment pulse occurs in the T_2 or T_3 state of a TCNT byte write cycle, writing takes priority and TCNT is not incremented. The TCNT byte that was not written retains its previous value. See figure 8-63, which shows an increment pulse occurring in the T_2 state of a byte write to TCNTH.

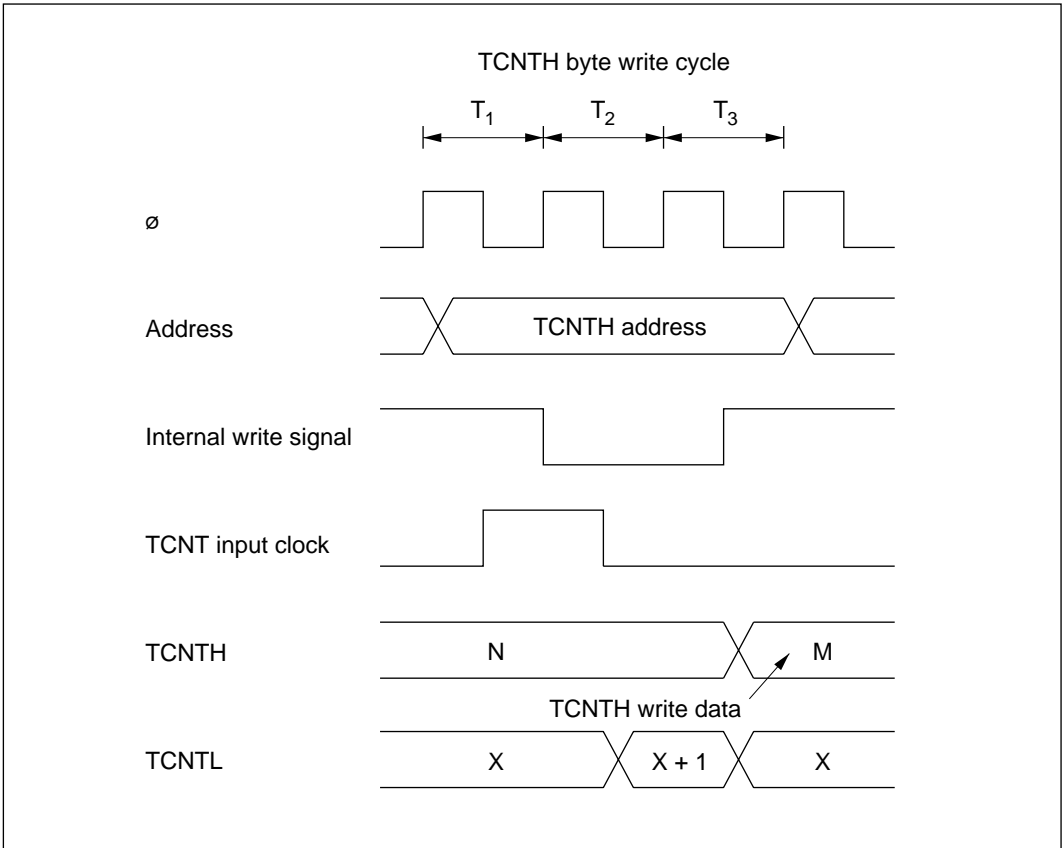

Figure 8-63 Contention between TCNT Byte Write and Increment

Contention between General Register Write and Compare Match: If a compare match occurs in the T_3 state of a general register write cycle, writing takes priority and the compare match signal is inhibited. See figure 8-64.

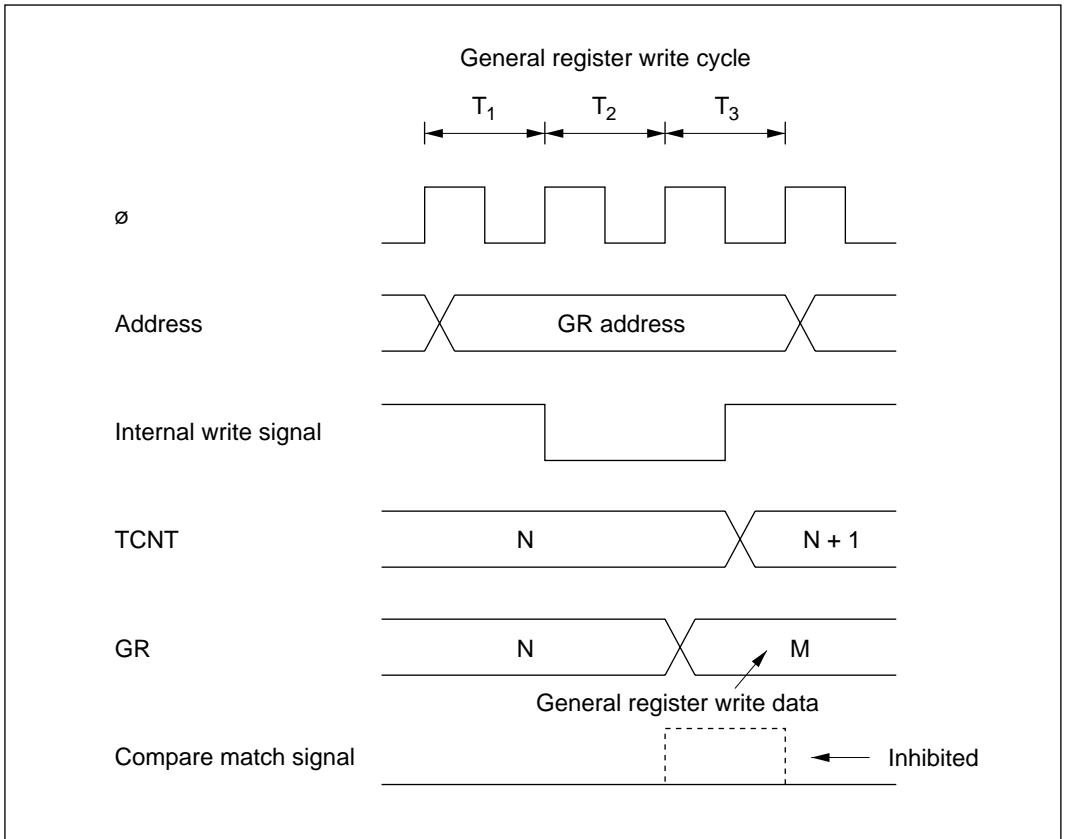

Figure 8-64 Contention between General Register Write and Compare Match

Contention between TCNT Write and Overflow or Underflow: If an overflow occurs in the T_3 state of a TCNT write cycle, writing takes priority and the counter is not incremented. OVF is set to 1. The same holds for underflow. See figure 8-65.

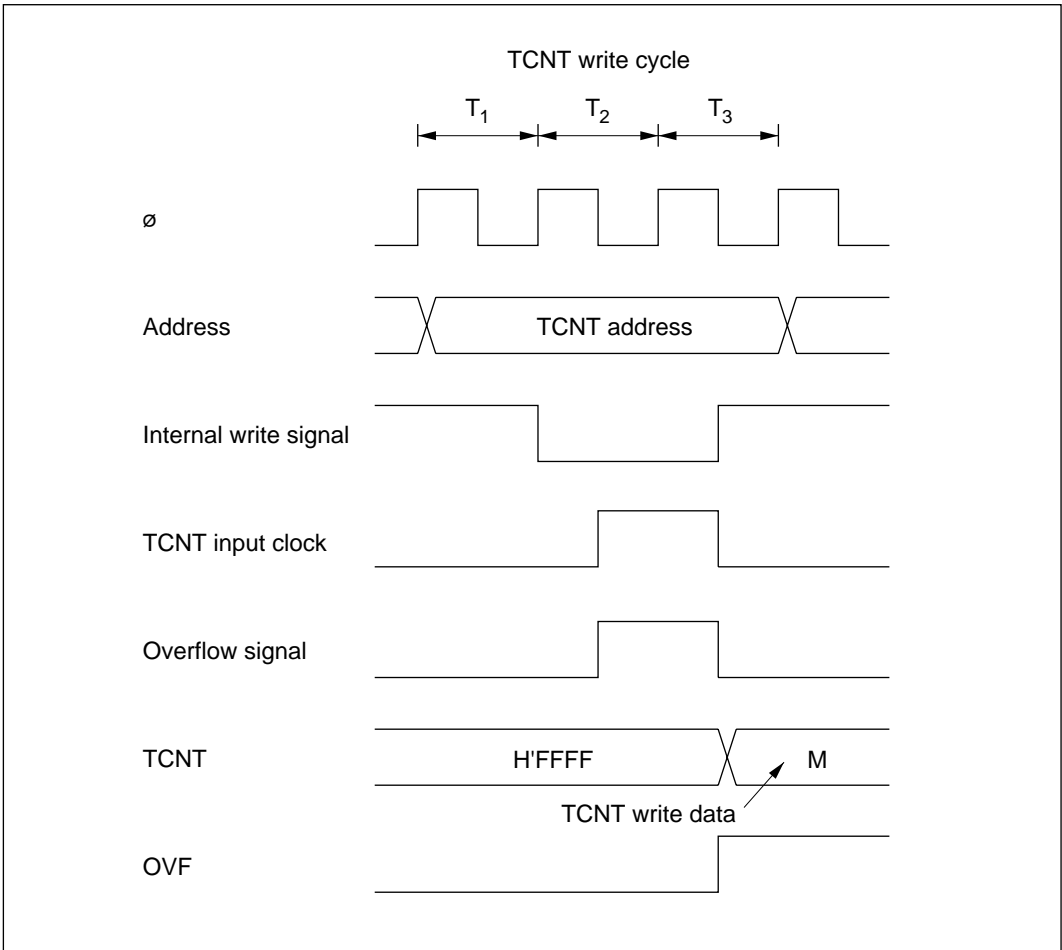

Figure 8-65 Contention between TCNT Write and Overflow

Contention between General Register Read and Input Capture: If an input capture signal occurs during the T_3 state of a general register read cycle, the value before input capture is read. See figure 8-66.

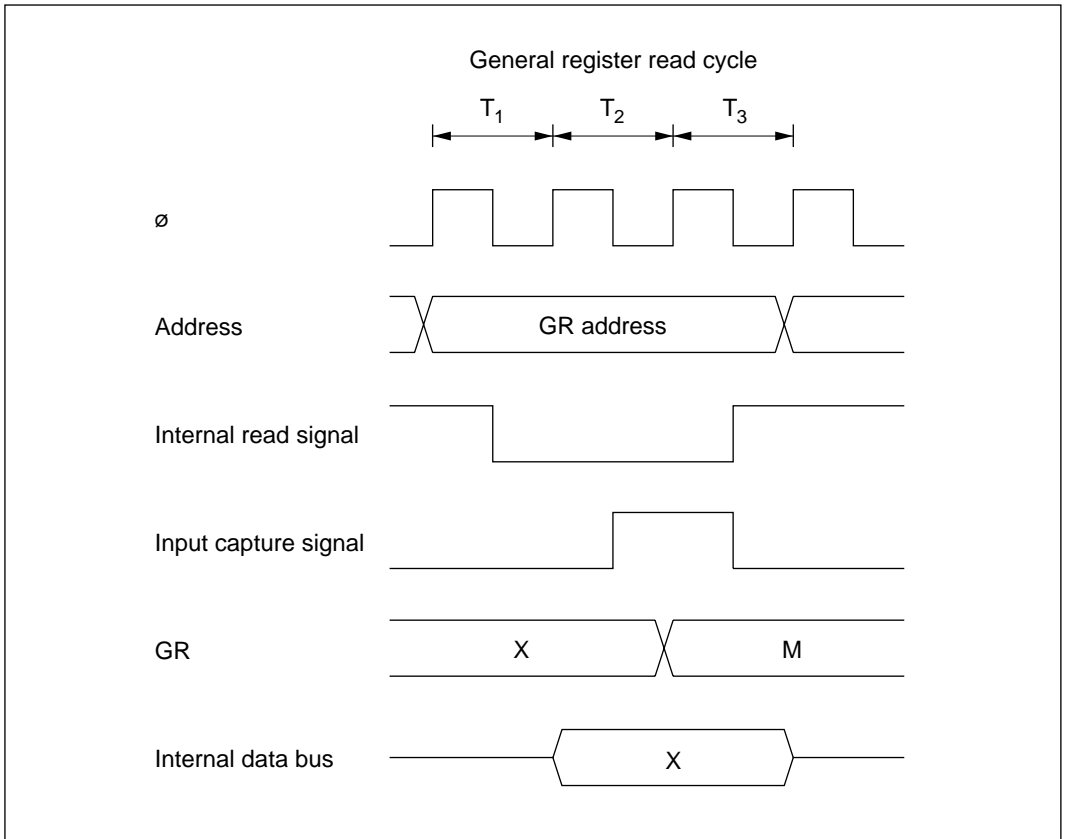

Figure 8-66 Contention between General Register Read and Input Capture

Contention between Counter Clearing by Input Capture and Counter Increment: If an input capture signal and counter increment signal occur simultaneously, the counter is cleared according to the input capture signal. The counter is not incremented by the increment signal. The value before the counter is cleared is transferred to the general register. See figure 8-67.

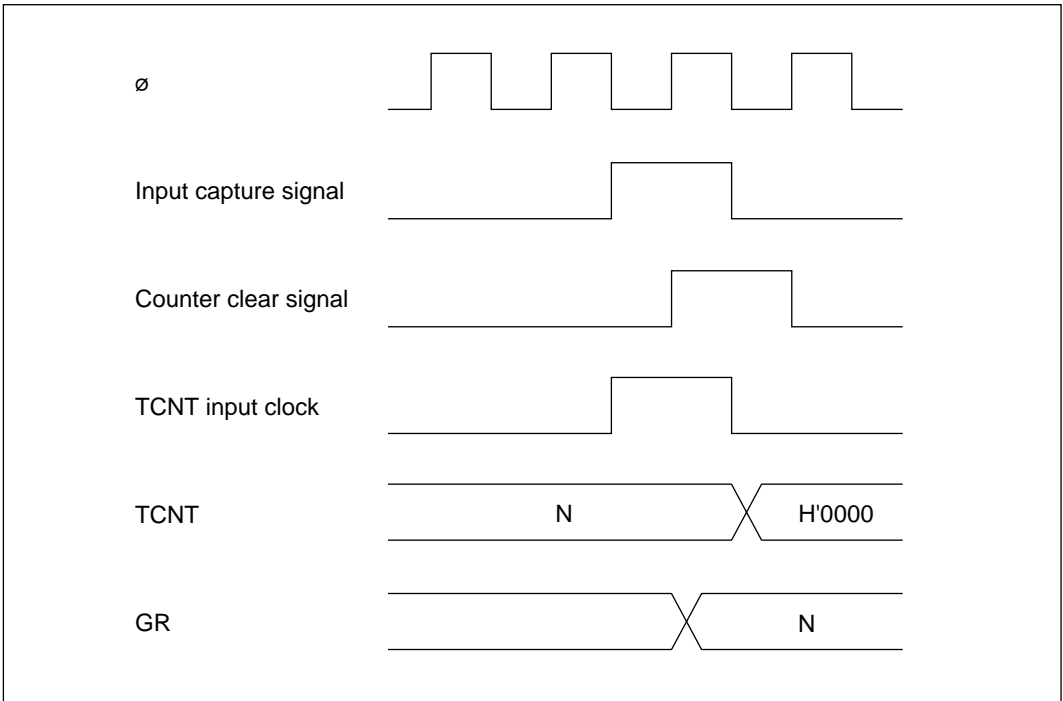

Figure 8-67 Contention between Counter Clearing by Input Capture and Counter Increment

Contention between General Register Write and Input Capture: If an input capture signal occurs in the T₃ state of a general register write cycle, input capture takes priority and the write to the general register is not performed. See figure 8-68.

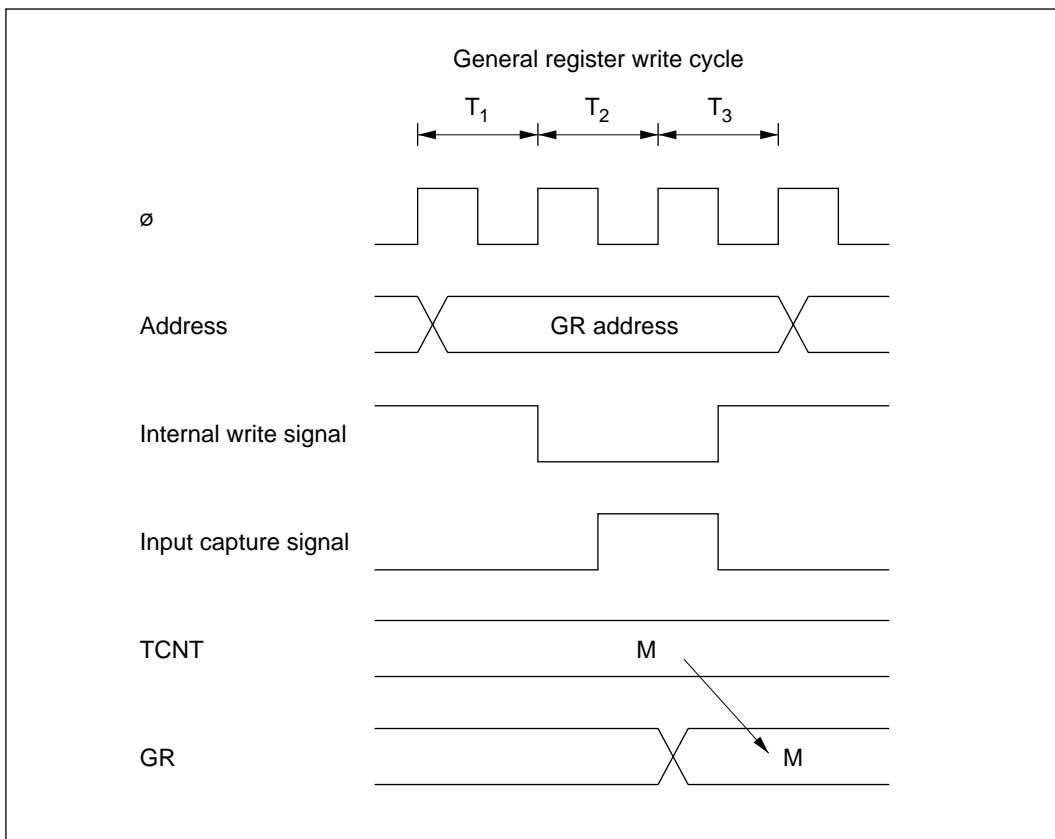

Figure 8-68 Contention between General Register Write and Input Capture

Note on Waveform Period Setting: When a counter is cleared by compare match, the counter is cleared in the last state at which the TCNT value matches the general register value, at the time when this value would normally be updated to the next count. The actual counter frequency is therefore given by the following formula:

$$f = \frac{\phi}{(N + 1)}$$

(f: counter frequency. ϕ : system clock frequency. N: value set in general register.)

Contention between Buffer Register Write and Input Capture: If a buffer register is used for input capture buffering and an input capture signal occurs in the T_3 state of a write cycle, input capture takes priority and the write to the buffer register is not performed.

See figure 8-69.

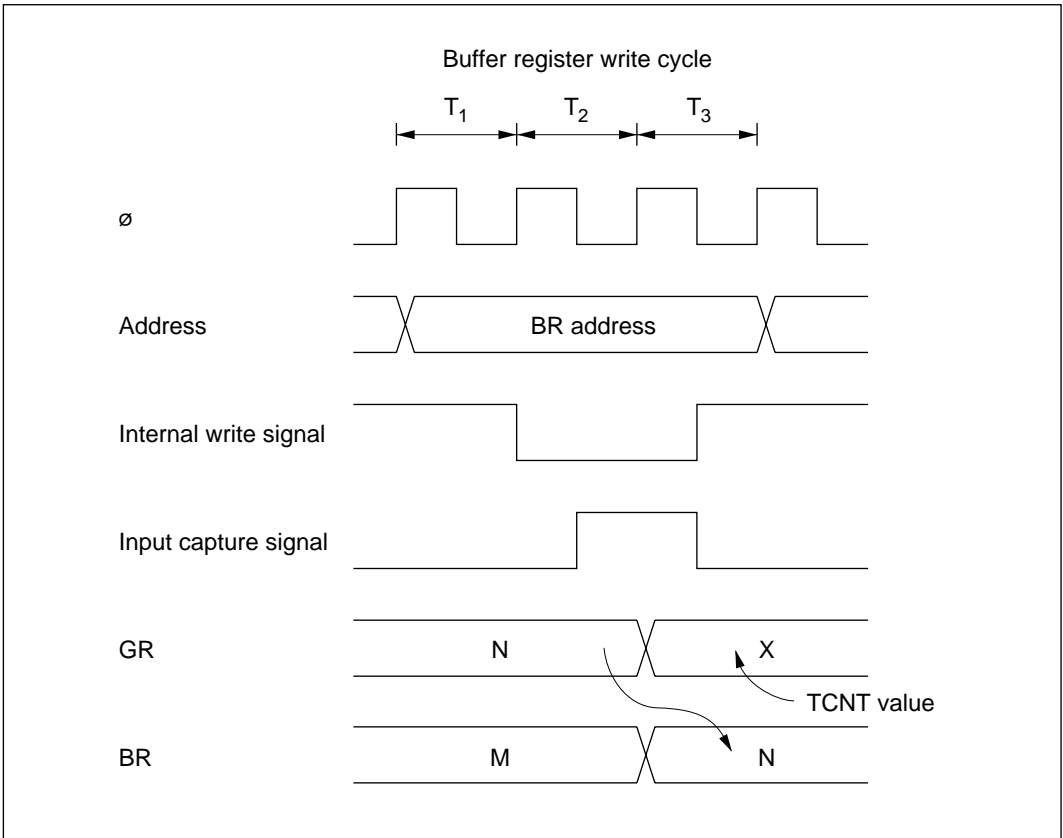
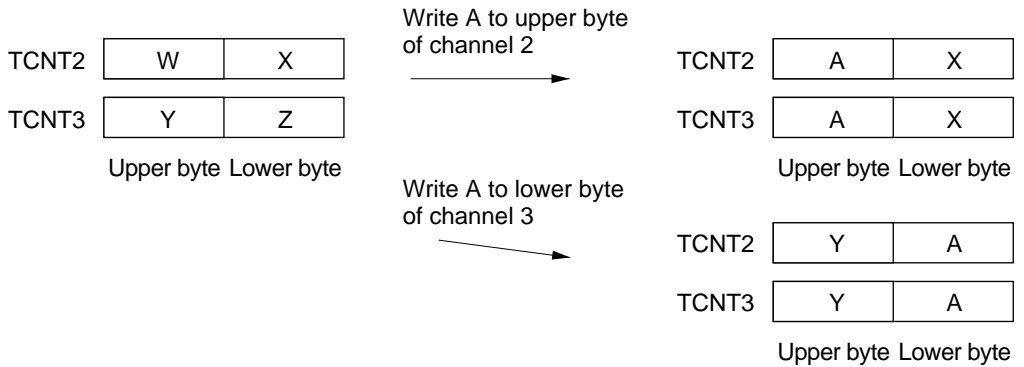

Figure 8-69 Contention between Buffer Register Write and Input Capture

Note on Synchronous Preset: When channels are synchronized, if a TCNT value is modified by byte write access, all 16 bits of all synchronized counters assume the same value as the counter that was addressed.

(Example) When channels 2 and 3 are synchronized

- Byte write to channel 2 or byte write to channel 3



- Word write to channel 2 or word write to channel 3

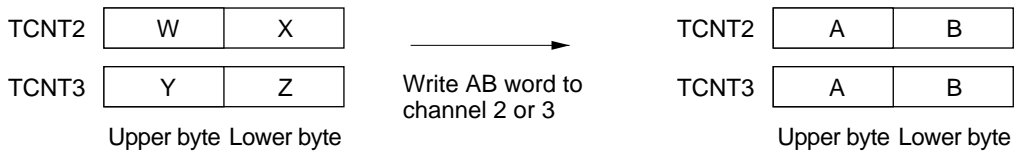

Note on Setup of Reset-Synchronized PWM Mode and Complementary PWM Mode: When setting bits CMD1 and CMD0 in TFCR, take the following precautions:

- Write to bits CMD1 and CMD0 only when TCNT3 and TCNT4 are stopped.
- Do not switch directly between reset-synchronized PWM mode and complementary PWM mode. First switch to normal mode (by clearing bit CMD1 to 0), then select reset-synchronized PWM mode or complementary PWM mode.

ITU Operating Modes

Table 8-11 (a) ITU Operating Modes (Channel 0)

Operating Mode	Register Settings													
	TSNC	TMDR		TFCR		TOCR		TOER	TIOR0		TCR0			
	Synchro- nization	MDF	FDIR	PWM	Comple- mentary PWM	Reset- Synchro- nized PWM	Buffer- ing	XTGD	Output Level Select	Master Enable	IOA	IOB	Clear Select	Clock Select
Synchronous preset	SYNC0 = 1	—	—	—	—	—	—	—	—	—	—	—	—	—
PWM mode	—	—	—	PWM0 = 1	—	—	—	—	—	—	—	*	—	—
Output compare A	—	—	—	PWM0 = 0	—	—	—	—	—	—	IOA2 = 0 Other bits unrestricted	—	—	—
Output compare B	—	—	—	—	—	—	—	—	—	—	—	IOB2 = 0 Other bits unrestricted	—	—
Input capture A	—	—	—	PWM0 = 0	—	—	—	—	—	—	IOA2 = 1 Other bits unrestricted	—	—	—
Input capture B	—	—	—	PWM0 = 0	—	—	—	—	—	—	—	IOB2 = 1 Other bits unrestricted	—	—
Counter clearing match/input capture A	—	—	—	—	—	—	—	—	—	—	—	—	—	CCLR1 = 0 CCLR0 = 1
By compare match/input capture B	—	—	—	—	—	—	—	—	—	—	—	—	—	CCLR1 = 1 CCLR0 = 0
Syn- chronous clear	SYNC0 = 1	—	—	—	—	—	—	—	—	—	—	—	—	CCLR1 = 1 CCLR0 = 1

Legend: ○ Setting available (valid). — Setting does not affect this mode.

Note: * The input capture function cannot be used in PWM mode. If compare match A and compare match B occur simultaneously, the compare match signal is inhibited.

Table 8-11 (b) ITU Operating Modes (Channel 1)

Register Settings														
TSNC	TMDR			TFCR		TOCR		TOER	TIOR1		TCR1			
Operating Mode	Synchro- nization	MDF	FDIR	PWM	Comple- mentary PWM	Reset- Synchro- nized PWM	Buffer- ing	XTGD	Output Level Select	Master Enable	IOA	IOB	Clear Select	Clock Select
Synchronous preset	SYNC1 = 1	—	—	—	—	—	—	—	—	—	—	—	—	—
PWM mode	—	—	—	—	PWM1 = 1	—	—	—	—	—	—	0*1	—	—
Output compare A	—	—	—	—	PWM1 = 0	—	—	—	—	—	IOA2 = 0 Other bits unrestricted	—	—	—
Output compare B	—	—	—	—	—	—	—	—	—	—	—	IOB2 = 0 Other bits unrestricted	—	—
Input capture A	—	—	—	—	PWM1 = 0	—	—	0*2	—	—	IOA2 = 1 Other bits unrestricted	—	—	—
Input capture B	—	—	—	—	PWM1 = 0	—	—	—	—	—	—	IOB2 = 1 Other bits unrestricted	—	—
Counter By compare clearing match/input capture A	—	—	—	—	—	—	—	—	—	—	—	—	—	CCLR1 = 0 CCLR0 = 1
By compare match/input capture B	—	—	—	—	—	—	—	—	—	—	—	—	—	CCLR1 = 1 CCLR0 = 0
Syn- chronous clear	SYNC1 = 1	—	—	—	—	—	—	—	—	—	—	—	—	CCLR1 = 1 CCLR0 = 1

Legend: ○ Setting available (valid). — Setting does not affect this mode.

Notes: 1. The input capture function cannot be used in PWM mode. If compare match A and compare match B occur simultaneously, the compare match signal is inhibited.
2. Valid only when channels 3 and 4 are operating in complementary PWM mode or reset-synchronized PWM mode.

Table 8-11 (c) ITU Operating Modes (Channel 2)

Operating Mode	Register Settings													
	TSNC	TMDR			TFCR		TOCR		TOER	TIOR2		TCR2		
	Synchro- nization	MDF	FDIR	PWM	Comple- mentary PWM	Reset- Synchro- nized PWM	Buffer- ing	XTGD	Output Level Select	Master Enable	IOA	IOB	Clear Select	Clock Select
Synchronous preset	SYNC2 = 1	0	—	0	—	—	—	—	—	—	0	0	0	0
PWM mode	0	0	—	PWM2 = 1	—	—	—	—	—	—	—	0*	0	0
Output compare A	0	0	—	PWM2 = 0	—	—	—	—	—	—	IOA2 = 0 Other bits unrestricted	0	0	0
Output compare B	0	0	—	0	—	—	—	—	—	—	IOB2 = 0 Other bits unrestricted	0	0	0
Input capture A	0	—	—	PWM2 = 0	—	—	—	—	—	—	IOA2 = 1 Other bits unrestricted	0	0	0
Input capture B	0	—	—	PWM2 = 0	—	—	—	—	—	—	IOB2 = 1 Other bits unrestricted	0	0	0
Counter By compare clearing match/input capture A	0	0	—	0	—	—	—	—	—	—	0	0	CCLR1 = 0 CCLR0 = 1	0
By compare match/input capture B	0	0	—	0	—	—	—	—	—	—	0	0	CCLR1 = 1 CCLR0 = 0	0
Syn- chronous clear	SYNC2 = 1	0	—	0	—	—	—	—	—	—	0	0	CCLR1 = 1 CCLR0 = 1	0
Phase counting mode	0	MDF = 1	0	0	—	—	—	—	—	—	0	0	0	—

Legend: 0 Setting available (valid). — Setting does not affect this mode.

Note: * The input capture function cannot be used in PWM mode. If compare match A and compare match B occur simultaneously, the compare match signal is inhibited.

Table 8-11 (d) ITU Operating Modes (Channel 3)

Register Settings															
TSNC			TMDR			TFRC			TOCR			TIOR3		TCR3	
Operating Mode	Synchro- nization	MDF	FDIR	PWM	Comple- mentary PWM	Reset- Synchro- nized PWM	Buffering	XTGD	Output Level Select	Master Enable	IOA	IOB	Clear Select	Clock Select	
Synchronous preset	SYNC3 = 1	—	—	—	—	—	—	—	—	—	—	—	—	—	
PWM mode	—	—	—	PWM3 = 1	CMD1 = 0	CMD1 = 0	—	—	—	—	—	—	—	—	
Output compare A	—	—	—	PWM3 = 0	CMD1 = 0	CMD1 = 0	—	—	—	—	IOA2 = 0 Other bits unrestricted	—	—	—	
Output compare B	—	—	—	—	CMD1 = 0	CMD1 = 0	—	—	—	—	—	IOB2 = 0 Other bits unrestricted	—	—	
Input capture A	—	—	—	PWM3 = 0	CMD1 = 0	CMD1 = 0	—	—	—	—	IOA2 = 1 Other bits unrestricted	—	—	—	
Input capture B	—	—	—	PWM3 = 0	CMD1 = 0	CMD1 = 0	—	—	—	—	IOA2 = 1 Other bits unrestricted	—	—	—	
Counter clearing capture A	—	—	—	—	Illegal setting: CMD1 = 1 CMD0 = 0	—	—	—	—	—	—	—	—	—	
Counter clearing capture B	—	—	—	—	Illegal setting: CMD1 = 1 CMD0 = 0	—	—	—	—	—	—	—	—	—	
Syn- chronous clear	SYNC3 = 1	—	—	—	Illegal setting: CMD1 = 1 CMD0 = 0	—	—	—	—	—	—	—	—	—	
Complementary PWM mode	—	—	—	—	CMD1 = 1 CMD0 = 0	CMD1 = 1 CMD0 = 0	—	—	—	—	—	—	—	—	
Reset-synchronized PWM mode	—	—	—	—	CMD1 = 1 CMD0 = 1	CMD1 = 1 CMD0 = 1	—	—	—	—	—	—	—	—	
Buffering (BRA)	—	—	—	—	—	BFA3 = 1 Other bits unrestricted	—	—	—	—	—	—	—	—	
Buffering (BRB)	—	—	—	—	—	BFB3 = 1 Other bits unrestricted	—	—	—	—	—	—	—	—	

Legend: ○ Setting available (valid). — Setting does not affect this mode.

- Notes:
1. Master enable bit settings are valid only during waveform output.
 2. The input capture function cannot be used in PWM mode. If compare match A and compare match B occur simultaneously, the compare match signal is inhibited.
 3. Do not set both channels 3 and 4 for synchronous operation when complementary PWM mode is selected.
 4. The counter cannot be cleared by input capture A when reset-synchronized PWM mode is selected.
 5. In complementary PWM mode, select the same clock source for channels 3 and 4.
 6. Use the input capture A function in channel 1.

Table 8-11 (e) ITU Operating Modes (Channel 4)

Operating Mode	Register Settings												
	TSNC	TMDR			TFCR			TOCR		TOER		TIOR4	
Synchro- nization	MDF	FDIR	PWM	Comple- mentary PWM	Reset- Synchro- nized PWM	Buffering	XTGD	Output Level Select	Master Enable	IOA	IOB	Clear Select	Clock Select
Synchronous preset	SYNCA = 1	—	—	—	○ ³	○	—	—	○ ¹	○	○	○	○
PWM mode	○	—	—	PWM4 = 1	CMD1 = 0	○	—	—	○	—	○ ²	○	○
Output compare A	○	—	—	PWM4 = 0	CMD1 = 0	○	—	—	○	IOA2 = 0 Other bits unrestricted	○	○	○
Output compare B	○	—	—	○	CMD1 = 0	○	—	—	○	○	IOB2 = 0 Other bits unrestricted	○	○
Input capture A	○	—	—	PWM4 = 0	CMD1 = 0	○	—	—	○	EA4 ignored Other bits unrestricted	IOA2 = 1 Other bits unrestricted	○	○
Input capture B	○	—	—	PWM4 = 0	CMD1 = 0	○	—	—	○	EB4 ignored Other bits unrestricted	IOB2 = 1 Other bits unrestricted	○	○
Counter By compare match/input capture A	○	—	—	○	Illegal setting: CMD1 = 1 CMD0 = 0	○	—	—	○ ¹	○	○	CCLR1 = 0 CCLR0 = 1	○
Counter By compare match/input capture B	○	—	—	○	Illegal setting: CMD1 = 1 CMD0 = 0	○	—	—	○ ¹	○	○	CCLR1 = 1 CCLR0 = 0	○
Syn- chronous clear	SYNCA = 1	—	—	○	Illegal setting: CMD1 = 1 CMD0 = 0	○	—	—	○ ¹	○	○	CCLR1 = 1 CCLR0 = 1	○
Complementary PWM mode	○ ³	—	—	—	CMD1 = 1 CMD0 = 0	○	○	○	○	—	—	CCLR1 = 0 CCLR0 = 0	○ ⁵
Reset-synchronized PWM mode	○	—	—	—	CMD1 = 1 CMD0 = 1	○	○	○	○	—	—	○ ⁶	○ ⁶
Buffering (BRA)	○	—	—	○	○	BFA4 = 1 Other bits unrestricted	—	—	○ ¹	○	○	○	○
Buffering (BRB)	○	—	—	○	○	BFB4 = 1 Other bits unrestricted	—	—	○ ¹	○	○	○	○

Legend: ○ Setting available (valid). — Setting does not affect this mode.

- Notes:
1. Master enable bit settings are valid only during waveform output.
 2. The input capture function cannot be used in PWM mode. If compare match A and compare match B occur simultaneously, the compare match signal is inhibited.
 3. Do not set both channels 3 and 4 for synchronous operation when complementary PWM mode is selected.
 4. When reset-synchronized PWM mode is selected, TCNT4 operates independently and the counter clearing function is available. Waveform output is not affected.
 5. In complementary PWM mode, select the same clock source for channels 3 and 4.
 6. TCR4 settings are valid in reset-synchronized PWM mode, but TCNT4 operates independently, without affecting waveform output.

Section 9 Watchdog Timer

9.1 Overview

The H8/3004 and H8/3005 have an on-chip watchdog timer (WDT). The WDT has two selectable functions: it can operate as a watchdog timer to supervise system operation, or it can operate as an interval timer. As a watchdog timer, it generates a reset signal for the H8/3004 and H8/3005 chip if a system crash allows the timer counter (TCNT) to overflow before being rewritten. In interval timer operation, an interval timer interrupt is requested at each TCNT overflow.

9.1.1 Features

WDT features are listed below.

- Selection of eight counter clock sources
 $\phi/2$, $\phi/32$, $\phi/64$, $\phi/128$, $\phi/256$, $\phi/512$, $\phi/2048$, or $\phi/4096$
- Interval timer option
- Timer counter overflow generates a reset signal or interrupt.

The reset signal is generated in watchdog timer operation. An interval timer interrupt is generated in interval timer operation.

- Watchdog timer reset signal resets the entire H8/3004 and H8/3005 internally, and can also be output externally.

The reset signal generated by timer counter overflow during watchdog timer operation resets the entire H8/3004 and H8/3005 internally. An external reset signal can be output from the $\overline{\text{RESO}}$ pin to reset other system devices simultaneously.

9.1.2 Block Diagram

Figure 9-1 shows a block diagram of the WDT.

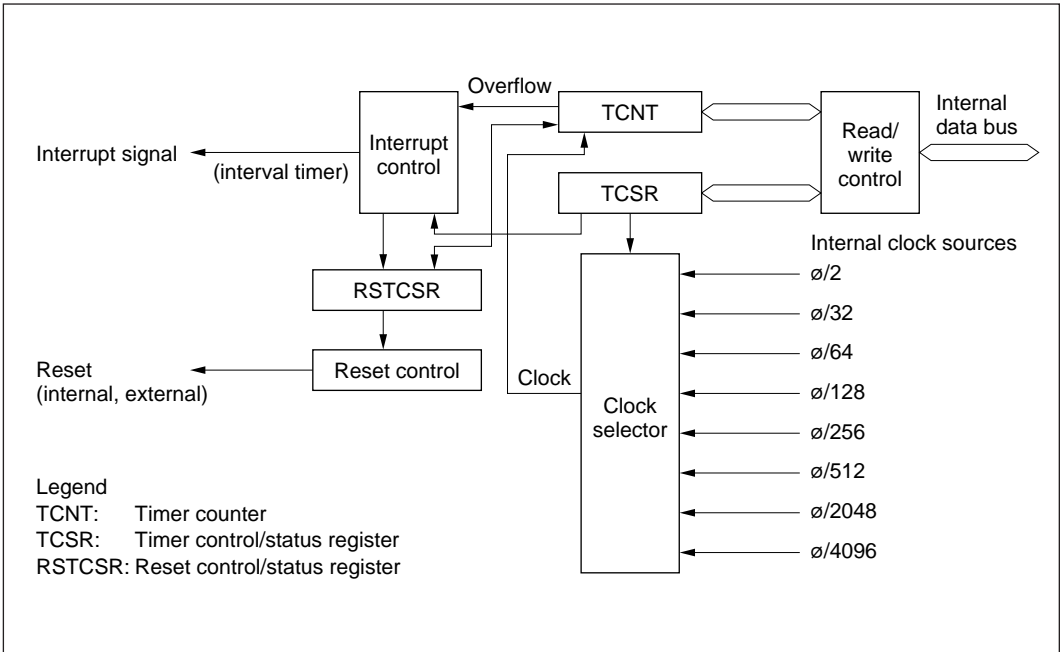

Figure 9-1 WDT Block Diagram

9.1.3 Pin Configuration

Table 9-1 describes the WDT output pin.

Table 9-1 WDT Pin

Name	Abbreviation	I/O	Function
Reset output	$\overline{\text{RESO}}$	Output*	External output of the watchdog timer reset signal

Note: * Open-drain output.

9.1.4 Register Configuration

Table 9-2 summarizes the WDT registers.

Table 9-2 WDT Registers

Address*1					
Write*2	Read	Name	Abbreviation	R/W	Initial Value
H'FFA8	H'FFA8	Timer control/status register	TCSR	R/(W)*3	H'18
	H'FFA9	Timer counter	TCNT	R/W	H'00
H'FFAA	H'FFAB	Reset control/status register	RSTCSR	R/(W)*3	H'3F

- Notes:
1. Lower 16 bits of the address.
 2. Write word data starting at this address.
 3. Only 0 can be written in bit 7, to clear the flag.

9.2 Register Descriptions

9.2.1 Timer Counter (TCNT)

TCNT is an 8-bit readable and writable* up-counter.

Bit	7	6	5	4	3	2	1	0
	<input type="checkbox"/>	<input type="checkbox"/>	<input type="checkbox"/>	<input type="checkbox"/>	<input type="checkbox"/>	<input type="checkbox"/>	<input type="checkbox"/>	<input type="checkbox"/>
Initial value	0	0	0	0	0	0	0	0
Read/Write	R/W	R/W	R/W	R/W	R/W	R/W	R/W	R/W

When the TME bit is set to 1 in TCSR, TCNT starts counting pulses generated from an internal clock source selected by bits CKS2 to CKS0 in TCSR. When the count overflows (changes from H'FF to H'00), the OVF bit is set to 1 in TCSR. TCNT is initialized to H'00 by a reset and when the TME bit is cleared to 0.

Note: * TCNT is write-protected by a password. For details see section 9.2.4, Notes on Register Access.

9.2.2 Timer Control/Status Register (TCSR)

TCSR is an 8-bit readable and writable*1 register. Its functions include selecting the timer mode and clock source.

Bit	7	6	5	4	3	2	1	0
	OVF	WT/ \overline{IT}	TME	—	—	CKS2	CKS1	CKS0
Initial value	0	0	0	1	1	0	0	0
Read/Write	R/(W)*2	R/W	R/W	—	—	R/W	R/W	R/W

Overflow flag
 Status flag indicating overflow

Timer mode select
 Selects the mode

Timer enable
 Selects whether TCNT runs or halts

Reserved bits

Clock select
 These bits select the TCNT clock source

Bits 7 to 5 are initialized to 0 by a reset and in standby mode. Bits 2 to 0 are initialized to 0 by a reset. In software standby mode bits 2 to 0 are not initialized, but retain their previous values.

Notes: 1. TCSR is write-protected by a password. For details see section 9.2.4, Notes on Register Access.

2. Only 0 can be written, to clear the flag.

Bit 7—Overflow Flag (OVF): This status flag indicates that the timer counter has overflowed from H'FF to H'00.

Bit 7 OVF	Description
0	[Clearing condition] Cleared by reading OVF when OVF = 1, then writing 0 in OVF (Initial value)
1	[Setting condition] Set when TCNT changes from H'FF to H'00

Bit 6—Timer Mode Select (WT/IT): Selects whether to use the WDT as a watchdog timer or interval timer. If used as an interval timer, the WDT generates an interval timer interrupt request when TCNT overflows. If used as a watchdog timer, the WDT generates a reset signal when TCNT overflows.

Bit 6 WT/IT	Description
0	Interval timer: requests interval timer interrupts (Initial value)
1	Watchdog timer: generates a reset signal

Bit 5—Timer Enable (TME): Selects whether TCNT runs or is halted.

Bit 5 TME	Description
0	TCNT is initialized to H'00 and halted (Initial value)
1	TCNT is counting

Bits 4 and 3—Reserved: Read-only bits, always read as 1.

Bits 2 to 0—Clock Select 2 to 0 (CKS2/1/0): These bits select one of eight internal clock sources, obtained by prescaling the system clock (ϕ), for input to TCNT.

Bit 2 CKS2	Bit 1 CKS1	Bit 0 CKS0	Description
0	0	0	$\phi/2$ (Initial value)
		1	$\phi/32$
	1	0	$\phi/64$
		1	$\phi/128$
1	0	0	$\phi/256$
		1	$\phi/512$
	1	0	$\phi/2048$
		1	$\phi/4096$

9.2.3 Reset Control/Status Register (RSTCSR)

RSTCSR is an 8-bit readable and writable*1 register that indicates when a reset signal has been generated by watchdog timer overflow, and controls external output of the reset signal.

Bit	7	6	5	4	3	2	1	0
	WRST	RSTOE	—	—	—	—	—	—
Initial value	0	0	1	1	1	1	1	1
Read/Write	R/(W)*2	R/W	—	—	—	—	—	—

Reserved bits

Reset output enable
Enables or disables external output of the reset signal

Watchdog timer reset
Indicates that a reset signal has been generated

Bits 7 and 6 are initialized by input of a reset signal at the $\overline{\text{RES}}$ pin. They are not initialized by reset signals generated by watchdog timer overflow.

Notes: 1. RSTCSR is write-protected by a password. For details see section 9.2.4, Notes on Register Access.

2. Only 0 can be written in bit 7, to clear the flag.

Bit 7—Watchdog Timer Reset (WRST): During watchdog timer operation, this bit indicates that TCNT has overflowed and generated a reset signal. This reset signal resets the entire H8/3004 or H8/3005 chip. If bit RSTOE is set to 1, this reset signal is also output (low) at the $\overline{\text{RESO}}$ pin to initialize external system devices.

Bit 7

WRST Description

0	[Clearing condition] Cleared to 0 by reset signal input at $\overline{\text{RES}}$ pin, or by writing 0	(Initial value)
1	[Setting condition] Set when TCNT overflow generates a reset signal during watchdog timer operation	

Bit 6—Reset Output Enable (RSTOE): Enables or disables external output at the $\overline{\text{RESO}}$ pin of the reset signal generated if TCNT overflows during watchdog timer operation.

Bit 6

RSTOE Description

0	Reset signal is not output externally	(Initial value)
1	Reset signal is output externally	

Bits 5 to 0—Reserved: Read-only bits, always read as 1.

9.2.4 Notes on Register Access

The watchdog timer's TCNT, TCSR, and RSTCSR registers differ from other registers in being more difficult to write. The procedures for writing and reading these registers are given below.

Writing to TCNT and TCSR: These registers must be written by a word transfer instruction. They cannot be written by byte instructions. Figure 9-2 shows the format of data written to TCNT and TCSR. TCNT and TCSR both have the same write address. The write data must be contained in the lower byte of the written word. The upper byte must contain H'5A (password for TCNT) or H'A5 (password for TCSR). This transfers the write data from the lower byte to TCNT or TCSR.

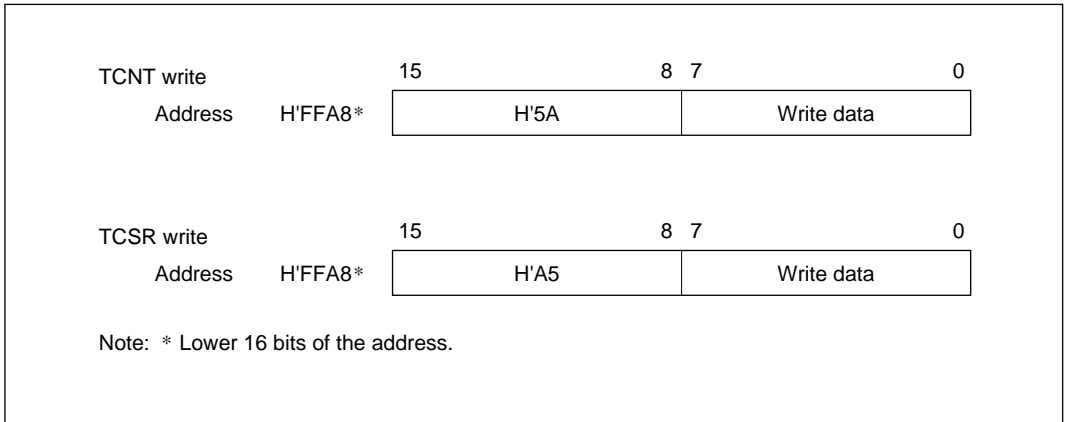

Figure 9-2 Format of Data Written to TCNT and TCSR

Writing to RSTCSR: RSTCSR must be written by a word transfer instruction. It cannot be written by byte transfer instructions. Figure 9-3 shows the format of data written to RSTCSR. To write 0 in the WRST bit, the write data must have H'A5 in the upper byte and H'00 in the lower byte. The H'00 in the lower byte clears the WRST bit in RSTCSR to 0. To write to the RSTOE bit, the upper byte must contain H'5A and the lower byte must contain the write data. Writing this word transfers a write data value into the RSTOE bit.

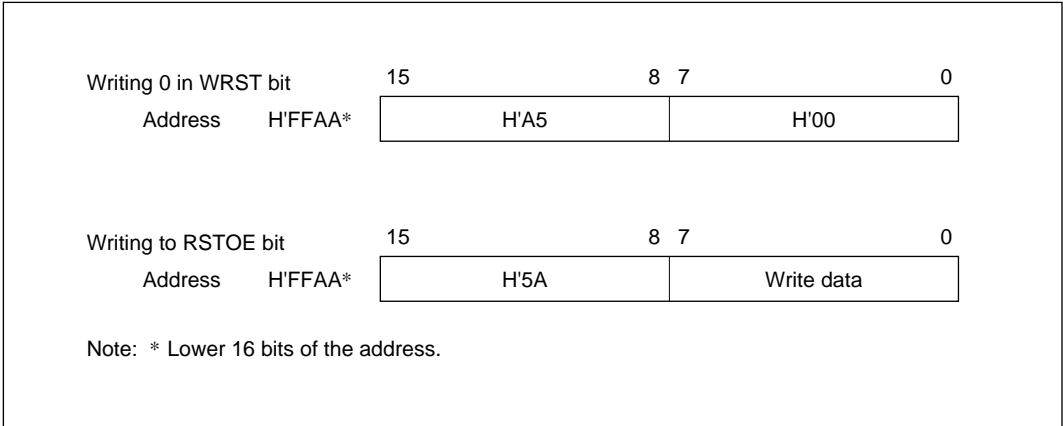

Figure 9-3 Format of Data Written to RSTCSR

Reading TCNT, TCSR, and RSTCSR: These registers are read like other registers. Byte access instructions can be used. The read addresses are H'FFA8 for TCSR, H'FFA9 for TCNT, and H'FFAB for RSTCSR, as listed in table 9-3.

Table 9-3 Read Addresses of TCNT, TCSR, and RSTCSR

Address*	Register
H'FFA8	TCSR
H'FFA9	TCNT
H'FFAB	RSTCSR

Note: * Lower 16 bits of the address.

9.3 Operation

Operations when the WDT is used as a watchdog timer and as an interval timer are described below.

9.3.1 Watchdog Timer Operation

Figure 9-4 illustrates watchdog timer operation. To use the WDT as a watchdog timer, set the $\overline{WT}/\overline{IT}$ and \overline{TME} bits to 1 in TCSR. Software must prevent TCNT overflow by rewriting the TCNT value (normally by writing H'00) before overflow occurs. If TCNT fails to be rewritten and overflows due to a system crash etc., the H8/3004 and H8/3005 are internally reset for a duration of 518 states.

The watchdog reset signal can be externally output from the \overline{RESO} pin to reset external system devices. The reset signal is output externally for 132 states. External output can be enabled or disabled by the \overline{RSTOE} bit in RSTCSR.

A watchdog reset has the same vector as a reset generated by input at the \overline{RES} pin. Software can distinguish a \overline{RES} reset from a watchdog reset by checking the \overline{WRST} bit in RSTCSR.

If a \overline{RES} reset and a watchdog reset occur simultaneously, the \overline{RES} reset takes priority.

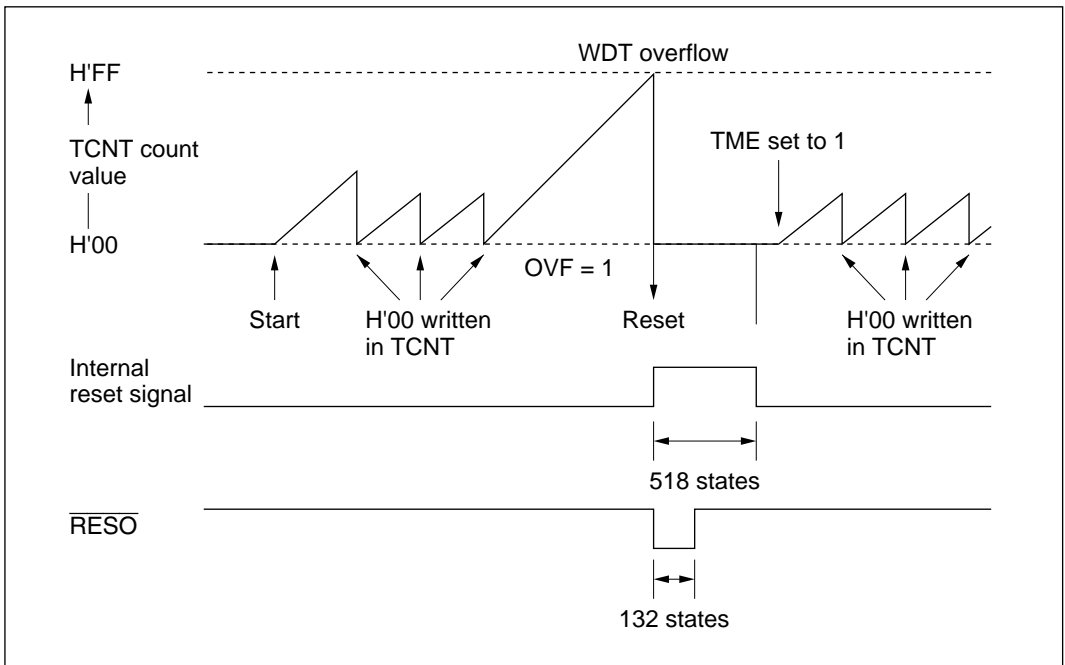

Figure 9-4 Watchdog Timer Operation

9.3.2 Interval Timer Operation

Figure 9-5 illustrates interval timer operation. To use the WDT as an interval timer, clear bit $\overline{WT/IT}$ to 0 and set bit TME to 1 in TCSR. An interval timer interrupt request is generated at each TCNT overflow. This function can be used to generate interval timer interrupts at regular intervals.

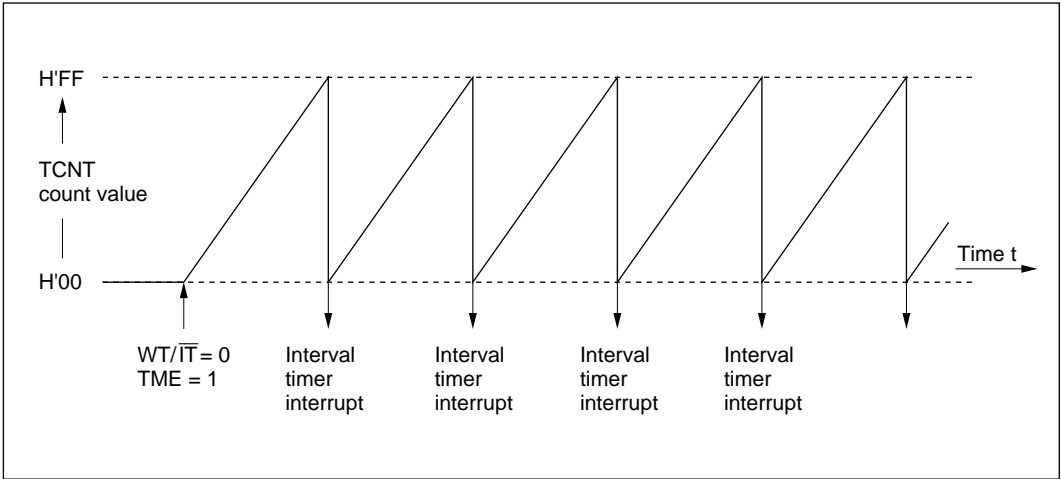

Figure 9-5 Interval Timer Operation

9.3.3 Timing of Setting of Overflow Flag (OVF)

Figure 9-6 shows the timing of setting of the OVF flag in TCSR. The OVF flag is set to 1 when TCNT overflows. At the same time, a reset signal is generated in watchdog timer operation, or an interval timer interrupt is generated in interval timer operation.

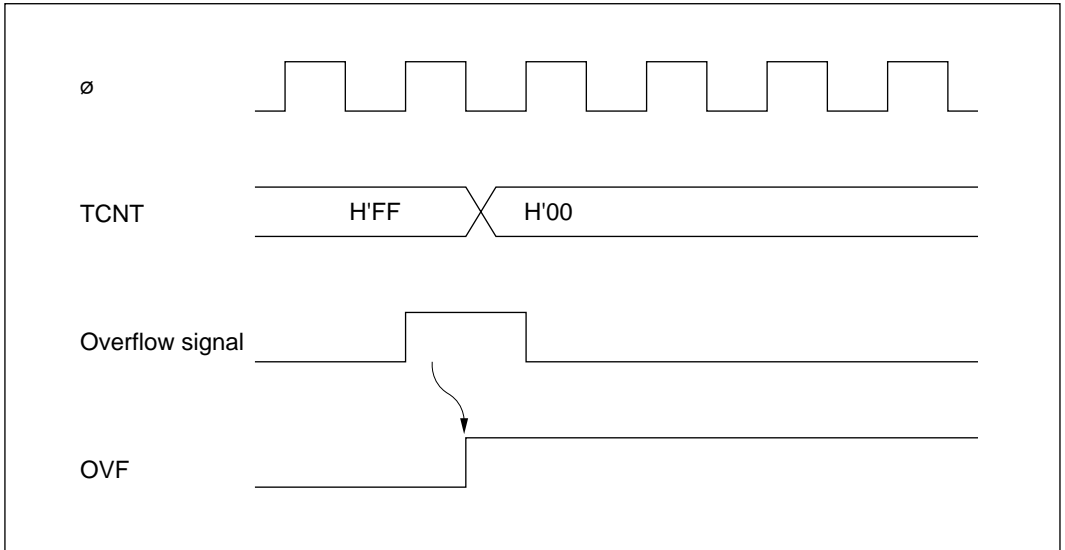

Figure 9-6 Timing of Setting of OVF

9.3.4 Timing of Setting of Watchdog Timer Reset Bit (WRST)

The WRST bit in RSTCSR is valid when bits WT/\overline{IT} and TME are both set to 1 in TCSR.

Figure 9-7 shows the timing of setting of WRST and the internal reset timing. The WRST bit is set to 1 when TCNT overflows and OVF is set to 1. At the same time an internal reset signal is generated for the entire H8/3004 and H8/3005 chip. This internal reset signal clears OVF to 0, but the WRST bit remains set to 1. The reset routine must therefore clear the WRST bit.

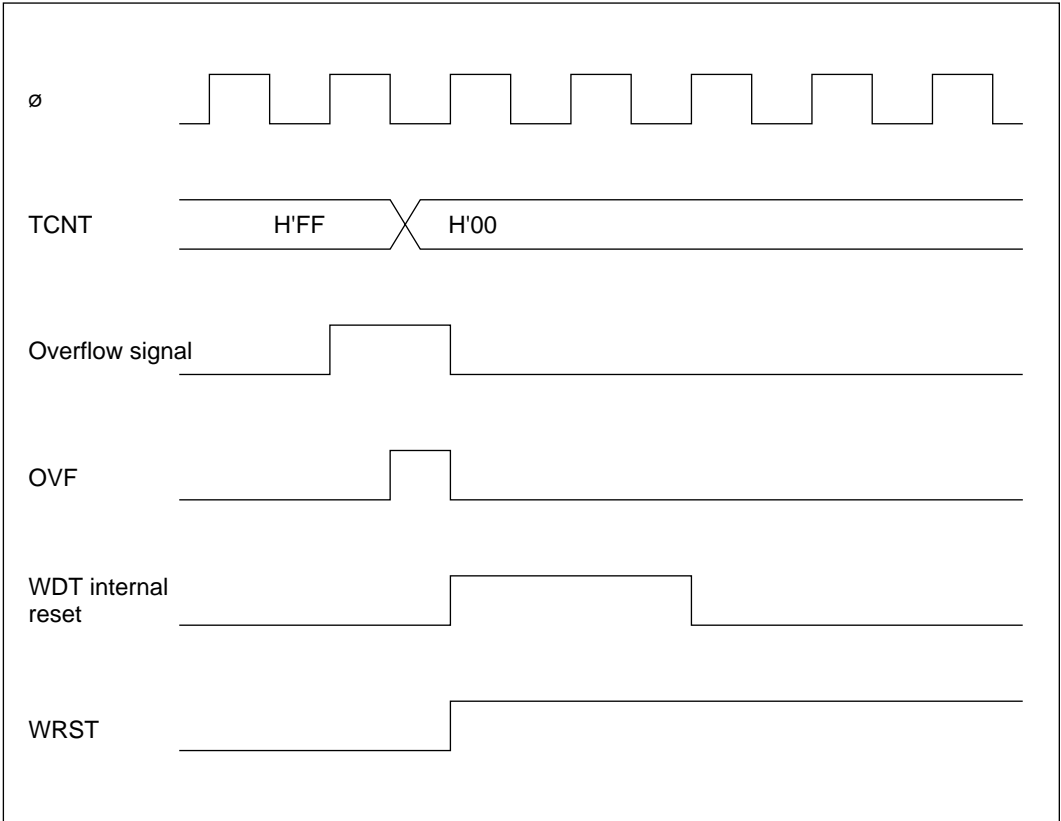

Figure 9-7 Timing of Setting of WRST Bit and Internal Reset

9.4 Interrupts

During interval timer operation, an overflow generates an interval timer interrupt (WOVI). The interval timer interrupt is requested whenever the OVF bit is set to 1 in TCSR.

9.5 Usage Notes

Contention between TCNT Write and Increment: If a timer counter clock pulse is generated during the T_3 state of a write cycle to TCNT, the write takes priority and the timer count is not incremented. See figure 9-8.

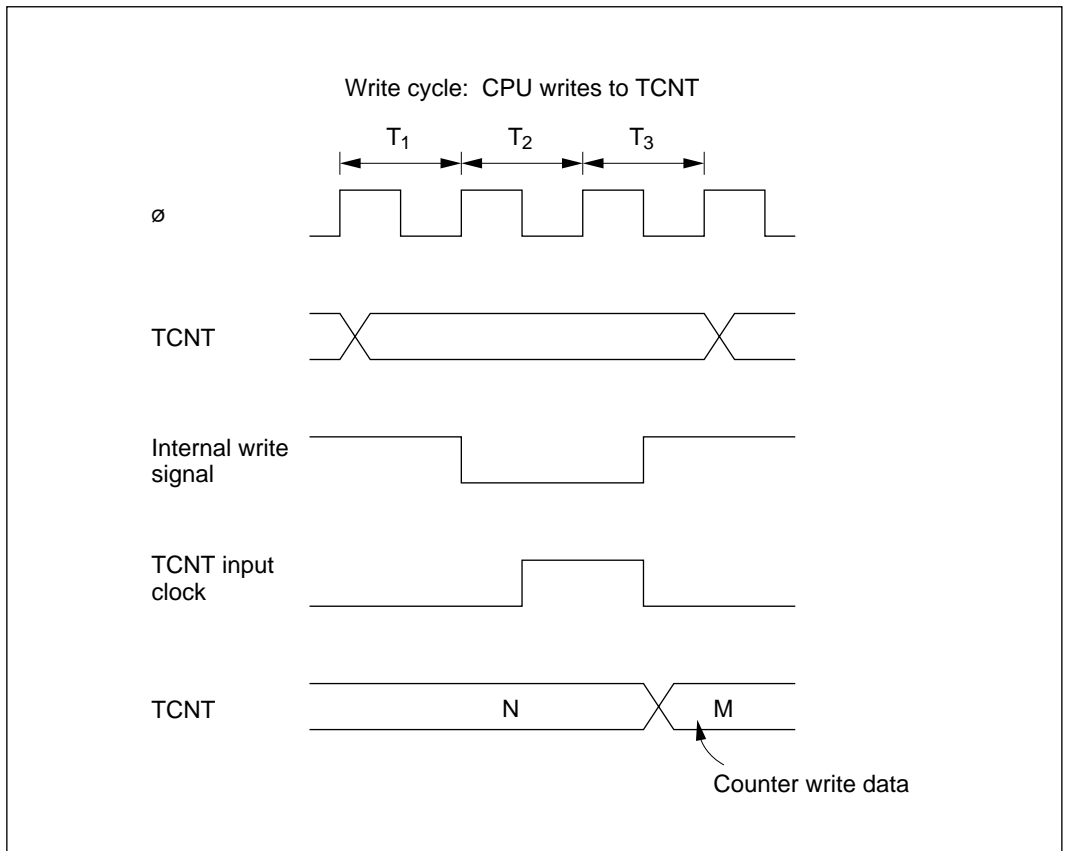

Figure 9-8 Contention between TCNT Write and Increment

Changing CKS2 to CKS0 Values: Halt TCNT by clearing the TME bit to 0 in TCSR before changing the values of bits CKS2 to CKS0.

Section 10 Serial Communication Interface

10.1 Overview

The H8/3004 and H8/3005 have a serial communication interface (SCI). The SCI can communicate in asynchronous mode or synchronous mode, and has a multiprocessor communication function for serial communication among two or more processors.

10.1.1 Features

SCI features are listed below.

- Selection of asynchronous or synchronous mode for serial communication
- a. Asynchronous mode

Serial data communication is synchronized one character at a time. The SCI can communicate with a universal asynchronous receiver/transmitter (UART), asynchronous communication interface adapter (ACIA), or other chip that employs standard asynchronous serial communication. It can also communicate with two or more other processors using the multiprocessor communication function. There are twelve selectable serial data communication formats.

- Data length: 7 or 8 bits
- Stop bit length: 1 or 2 bits
- Parity bit: even, odd, or none
- Multiprocessor bit: 1 or 0
- Receive error detection: parity, overrun, and framing errors
- Break detection: by reading the RxD level directly when a framing error occurs

- b. Synchronous mode

Serial data communication is synchronized with a clock signal. The SCI can communicate with other chips having a synchronous communication function. There is one serial data communication format.

- Data length: 8 bits
- Receive error detection: overrun errors

- Full duplex communication

The transmitting and receiving sections are independent, so the SCI can transmit and receive simultaneously. The transmitting and receiving sections are both double-buffered, so serial data can be transmitted and received continuously.

- Built-in baud rate generator with selectable bit rates
- Selectable transmit/receive clock sources: internal clock from baud rate generator, or external clock from the SCK pin.
- Four types of interrupts

Transmit-data-empty, transmit-end, receive-data-full, and receive-error interrupts are requested independently.

10.1.2 Block Diagram

Figure 10-1 shows a block diagram of the SCI.

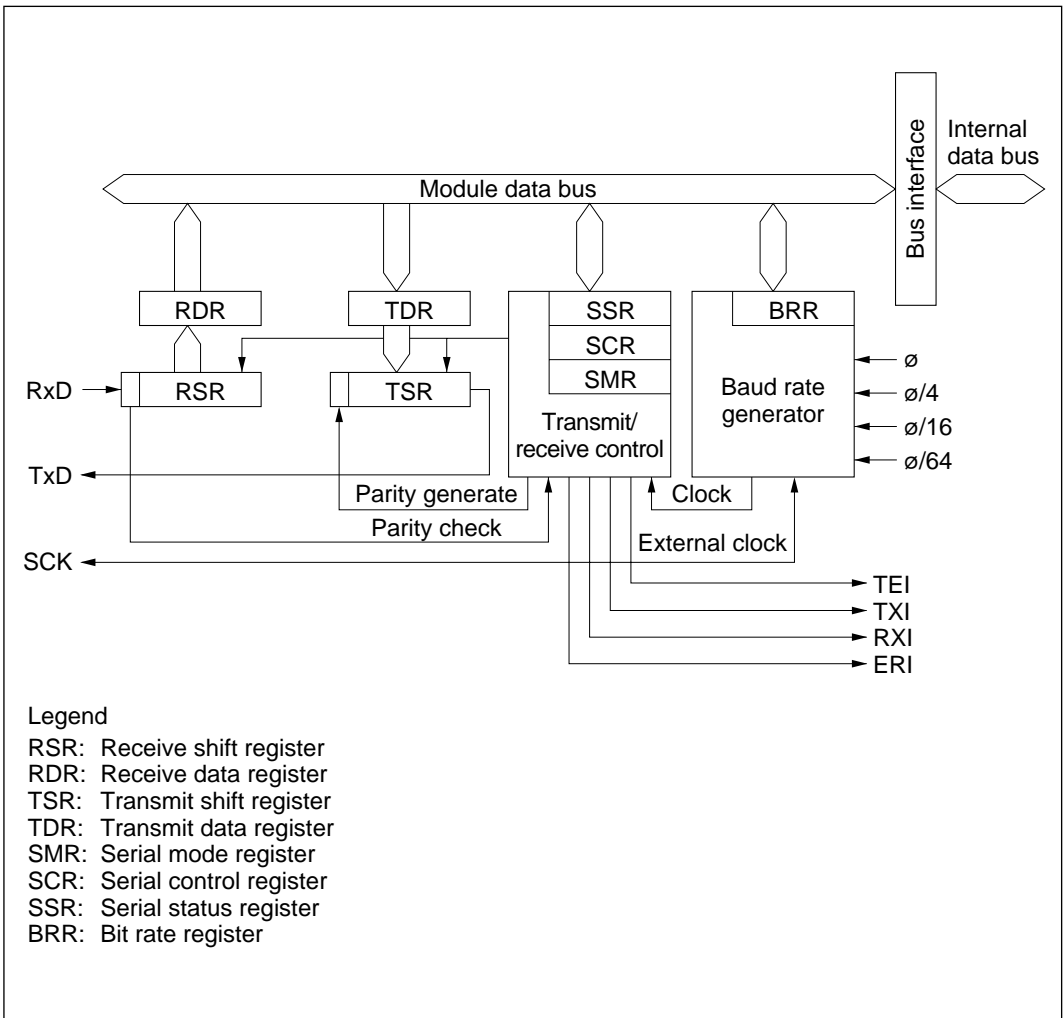

Figure 10-1 SCI Block Diagram

10.1.3 Input/Output Pins

The SCI has serial pins as listed in table 10-1.

Table 10-1 SCI Pins

Name	Abbreviation	I/O	Function
Serial clock pin	SCK	Input/output	SCI clock input/output
Receive data pin	RxD	Input	SCI receive data input
Transmit data pin	TxD	Output	SCI transmit data output

10.1.4 Register Configuration

The SCI has internal registers as listed in table 10-2. These registers select asynchronous or synchronous mode, specify the data format and bit rate, and control the transmitter and receiver sections.

Table 10-2 Registers

Address*1	Name	Abbreviation	R/W	Initial Value
H'FFB0	Serial mode register	SMR	R/W	H'00
H'FFB1	Bit rate register	BRR	R/W	H'FF
H'FFB2	Serial control register	SCR	R/W	H'00
H'FFB3	Transmit data register	TDR	R/W	H'FF
H'FFB4	Serial status register	SSR	R/(W)*2	H'84
H'FFB5	Receive data register	RDR	R	H'00

- Notes: 1. Lower 16 bits of the address.
2. Only 0 can be written, to clear flags.

10.2 Register Descriptions

10.2.1 Receive Shift Register (RSR)

RSR is the register that receives serial data.

Bit	7	6	5	4	3	2	1	0
Initial value								
Read/Write	—	—	—	—	—	—	—	—

The SCI loads serial data input at the RxD pin into RSR in the order received, LSB (bit 0) first, thereby converting the data to parallel data. When 1 byte has been received, it is automatically transferred to RDR. The CPU cannot read or write RSR directly.

10.2.2 Receive Data Register (RDR)

RDR is the register that stores received serial data.

Bit	7	6	5	4	3	2	1	0
Initial value	0	0	0	0	0	0	0	0
Read/Write	R	R	R	R	R	R	R	R

When the SCI finishes receiving 1 byte of serial data, it transfers the received data from RSR into RDR for storage. RSR is then ready to receive the next data. This double buffering allows data to be received continuously.

RDR is a read-only register. Its contents cannot be modified by the CPU. RDR is initialized to H'00 by a reset and in standby mode.

10.2.3 Transmit Shift Register (TSR)

TSR is the register that transmits serial data.

Bit	7	6	5	4	3	2	1	0
	<input type="checkbox"/>	<input type="checkbox"/>	<input type="checkbox"/>	<input type="checkbox"/>	<input type="checkbox"/>	<input type="checkbox"/>	<input type="checkbox"/>	<input type="checkbox"/>
Initial value								
Read/Write	—	—	—	—	—	—	—	—

The SCI loads transmit data from TDR into TSR, then transmits the data serially from the TxDP pin, LSB (bit 0) first. After transmitting one data byte, the SCI automatically loads the next transmit data from TDR into TSR and starts transmitting it. If the TDRE flag is set to 1 in SSR, however, the SCI does not load the TDR contents into TSR. The CPU cannot read or write TSR directly.

10.2.4 Transmit Data Register (TDR)

TDR is an 8-bit register that stores data for serial transmission.

Bit	7	6	5	4	3	2	1	0
	<input type="checkbox"/>	<input type="checkbox"/>	<input type="checkbox"/>	<input type="checkbox"/>	<input type="checkbox"/>	<input type="checkbox"/>	<input type="checkbox"/>	<input type="checkbox"/>
Initial value	1	1	1	1	1	1	1	1
Read/Write	R/W	R/W	R/W	R/W	R/W	R/W	R/W	R/W

When the SCI detects that TSR is empty, it moves transmit data written in TDR from TDR into TSR and starts serial transmission. Continuous serial transmission is possible by writing the next transmit data in TDR during serial transmission from TSR.

The CPU can always read and write TDR. TDR is initialized to H'FF by a reset and in standby mode.

10.2.5 Serial Mode Register (SMR)

SMR is an 8-bit register that specifies the SCI serial communication format and selects the clock source for the baud rate generator.

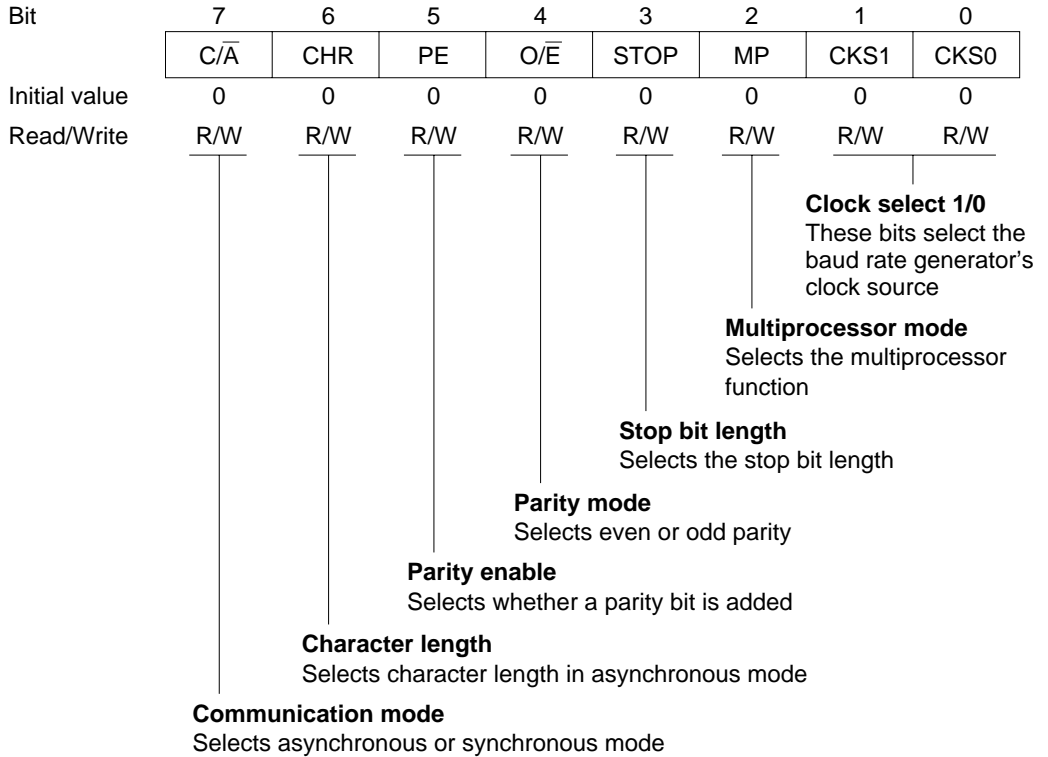

The CPU can always read and write SMR. SMR is initialized to H'00 by a reset and in standby mode.

Bit 7—Communication Mode (C/ \bar{A}): Selects whether the SCI operates in asynchronous or synchronous mode.

Bit 7

C/ \bar{A}	Description	
0	Asynchronous mode	(Initial value)
1	Synchronous mode	

Bit 6—Character Length (CHR): Selects 7-bit or 8-bit data length in asynchronous mode. In synchronous mode the data length is 8 bits regardless of the CHR setting.

Bit 6

CHR	Description	
0	8-bit data	(Initial value)
1	7-bit data*	

Note: * When 7-bit data is selected, the MSB (bit 7) in TDR is not transmitted.

Bit 5—Parity Enable (PE): In asynchronous mode, this bit enables or disables the addition of a parity bit to transmit data, and the checking of the parity bit in receive data. In synchronous mode the parity bit is neither added nor checked, regardless of the PE setting.

Bit 5

PE	Description	
0	Parity bit not added or checked	(Initial value)
1	Parity bit added and checked*	

Note: * When PE is set to 1, an even or odd parity bit is added to transmit data according to the even or odd parity mode selected by the O/ \bar{E} bit, and the parity bit in receive data is checked to see that it matches the even or odd mode selected by the O/ \bar{E} bit.

Bit 4—Parity Mode (O/ \bar{E}): Selects even or odd parity. The O/ \bar{E} bit setting is valid in asynchronous mode when the PE bit is set to 1 to enable the adding and checking of a parity bit. The O/ \bar{E} setting is ignored in synchronous mode, or when parity adding and checking is disabled in asynchronous mode.

Bit 4

O/ \bar{E}	Description
0	Even parity*1 (Initial value)
1	Odd parity*2

- Notes:
1. When even parity is selected, the parity bit added to transmit data makes an even number of 1s in the transmitted character and parity bit combined. Receive data must have an even number of 1s in the received character and parity bit combined.
 2. When odd parity is selected, the parity bit added to transmit data makes an odd number of 1s in the transmitted character and parity bit combined. Receive data must have an odd number of 1s in the received character and parity bit combined.

Bit 3—Stop Bit Length (STOP): Selects one or two stop bits in asynchronous mode. This setting is used only in asynchronous mode. In synchronous mode no stop bit is added, so the STOP bit setting is ignored.

Bit 3

STOP	Description
0	One stop bit*1 (Initial value)
1	Two stop bits*2

- Notes:
1. One stop bit (with value 1) is added at the end of each transmitted character.
 2. Two stop bits (with value 1) are added at the end of each transmitted character.

In receiving, only the first stop bit is checked, regardless of the STOP bit setting. If the second stop bit is 1 it is treated as a stop bit. If the second stop bit is 0 it is treated as the start bit of the next incoming character.

Bit 2—Multiprocessor Mode (MP): Selects a multiprocessor format. When a multiprocessor format is selected, parity settings made by the PE and O/E bits are ignored. The MP bit setting is valid only in asynchronous mode. It is ignored in synchronous mode.

For further information on the multiprocessor communication function, see section 10.3.3, Multiprocessor Communication Function.

Bit 2 MP	Description	
0	Multiprocessor function disabled	(Initial value)
1	Multiprocessor format selected	

Bits 1 and 0—Clock Select 1 and 0 (CKS1/0): These bits select the clock source of the on-chip baud rate generator. Four clock sources are available: \emptyset , $\emptyset/4$, $\emptyset/16$, and $\emptyset/64$.

For the relationship between the clock source, bit rate register setting, and baud rate, see section 10.2.8, Bit Rate Register.

Bit 1 CKS1	Bit 0 CKS0	Description	
0	0	\emptyset	(Initial value)
	1	$\emptyset/4$	
1	0	$\emptyset/16$	
	1	$\emptyset/64$	

10.2.6 Serial Control Register (SCR)

SCR enables the SCI transmitter and receiver, enables or disables serial clock output in asynchronous mode, enables or disables interrupts, and selects the transmit/receive clock source.

Bit	7	6	5	4	3	2	1	0
	TIE	RIE	TE	RE	MPIE	TEIE	CKE1	CKE0
Initial value	0	0	0	0	0	0	0	0
Read/Write	R/W	R/W	R/W	R/W	R/W	R/W	R/W	R/W

Transmit interrupt enable
Enables or disables transmit-data-empty interrupts (TXI)

Receive interrupt enable
Enables or disables receive-data-full interrupts (RXI) and receive-error interrupts (ERI)

Transmit enable
Enables or disables the transmitter

Receive enable
Enables or disables the receiver

Multiprocessor interrupt enable
Enables or disables multiprocessor interrupts

Transmit end interrupt enable
Enables or disables transmit-end interrupts (TEI)

Clock enable 1/0
These bits select the SCI clock source

The CPU can always read and write SCR. SCR is initialized to H'00 by a reset and in standby mode.

Bit 7—Transmit Interrupt Enable (TIE): Enables or disables the transmit-data-empty interrupt (TXI) requested when the TDRE flag in SSR is set to 1 due to transfer of serial transmit data from TDR to TSR.

Bit 7

TIE	Description
0	Transmit-data-empty interrupt request (TXI) is disabled* (Initial value)
1	Transmit-data-empty interrupt request (TXI) is enabled

Note: * TXI interrupt requests can be cleared by reading the value 1 from the TDRE flag, then clearing it to 0; or by clearing the TIE bit to 0.

Bit 6—Receive Interrupt Enable (RIE): Enables or disables the receive-data-full interrupt (RXI) requested when the RDRF flag is set to 1 in SSR due to transfer of serial receive data from RSR to RDR; also enables or disables the receive-error interrupt (ERI).

Bit 6

RIE	Description
0	Receive-end (RXI) and receive-error (ERI) interrupt requests are disabled (Initial value)
1	Receive-end (RXI) and receive-error (ERI) interrupt requests are enabled

Note: * RXI and ERI interrupt requests can be cleared by reading the value 1 from the RDRF, FER, PER, or ORER flag, then clearing it to 0; or by clearing the RIE bit to 0.

Bit 5—Transmit Enable (TE): Enables or disables the start of SCI serial transmitting operations.

Bit 5

TE	Description
0	Transmitting disabled* ¹ (Initial value)
1	Transmitting enabled* ²

Notes: 1. The TDRE bit is locked at 1 in SSR.
2. In the enabled state, serial transmitting starts when the TDRE bit in SSR is cleared to 0 after writing of transmit data into TDR. Select the transmit format in SMR before setting the TE bit to 1.

Bit 4—Receive Enable (RE): Enables or disables the start of SCI serial receiving operations.

Bit 4

RE	Description
0	Receiving disabled* ¹ (Initial value)
1	Receiving enabled* ²

- Notes:
1. Clearing the RE bit to 0 does not affect the RDRF, FER, PER, and ORER flags. These flags retain their previous values.
 2. In the enabled state, serial receiving starts when a start bit is detected in asynchronous mode, or serial clock input is detected in synchronous mode. Select the receive format in SMR before setting the RE bit to 1.

Bit 3—Multiprocessor Interrupt Enable (MPIE): Enables or disables multiprocessor interrupts. The MPIE setting is valid only in asynchronous mode, and only if the MP bit is set to 1 in SMR. The MPIE setting is ignored in synchronous mode or when the MP bit is cleared to 0.

Bit 3

MPIE	Description
0	Multiprocessor interrupts are disabled (normal receive operation) (Initial value) [Clearing conditions] The MPIE bit is cleared to 0. MPB = 1 in received data.
1	Multiprocessor interrupts are enabled* Receive-data-full interrupts (RXI), receive-error interrupts (ERI), and setting of the RDRF, FER, and ORER status flags in SSR are disabled until data with the multiprocessor bit set to 1 is received.

Note: * The SCI does not transfer receive data from RSR to RDR, does not detect receive errors, and does not set the RDRF, FER, and ORER flags in SSR. When it receives data in which MPB = 1, the SCI sets the MPB bit to 1 in SSR, automatically clears the MPIE bit to 0, enables RXI and ERI interrupts (if the RIE bit is set to 1 in SCR), and allows the FER and ORER flags to be set.

Bit 2—Transmit-End Interrupt Enable (TEIE): Enables or disables the transmit-end interrupt (TEI) requested if TDR does not contain new transmit data when the MSB is transmitted.

Bit 2 TEIE	Description
0	Transmit-end interrupt requests (TEI) are disabled* (Initial value)
1	Transmit-end interrupt requests (TEI) are enabled*

Note: * TEI interrupt requests can be cleared by reading the value 1 from the TDRE flag in SSR, then clearing the TDRE flag to 0, thereby also clearing the TEND flag to 0; or by clearing the TEIE bit to 0.

Bits 1 and 0—Clock Enable 1 and 0 (CKE1/0): These bits select the SCI clock source and enable or disable clock output from the SCK pin. Depending on the settings of CKE1 and CKE0, the SCK pin can be used for generic input/output, serial clock output, or serial clock input.

The CKE0 setting is valid only in asynchronous mode, and only when the SCI is internally clocked (CKE1 = 0). The CKE0 setting is ignored in synchronous mode, or when an external clock source is selected (CKE1 = 1). Be sure to set the CKE1 and CKE0 bits before selecting the SCI operating mode in SMR. For further details on selection of the SCI clock source, see table 10-9 in section 10.3, Operation.

Bit 1 CKE1	Bit 0 CKE0	Description
0	0	Asynchronous mode Internal clock, SCK pin available for generic input/output *1
		Synchronous mode Internal clock, SCK pin used for serial clock output *1
	1	Asynchronous mode Internal clock, SCK pin used for clock output *2
		Synchronous mode Internal clock, SCK pin used for serial clock output
1	0	Asynchronous mode External clock, SCK pin used for clock input *3
		Synchronous mode External clock, SCK pin used for serial clock input
	1	Asynchronous mode External clock, SCK pin used for clock input *3
		Synchronous mode External clock, SCK pin used for serial clock input

- Notes: 1. Initial value
 2. The output clock frequency is the same as the bit rate.
 3. The input clock frequency is 16 times the bit rate.

10.2.7 Serial Status Register (SSR)

SSR is an 8-bit register containing multiprocessor bit values, and status flags that indicate SCI operating status.

Bit	7	6	5	4	3	2	1	0
	TDRE	RDRF	ORER	FER	PER	TEND	MPB	MPBT
Initial value	1	0	0	0	0	1	0	0
Read/Write	R/(W)*	R/(W)*	R/(W)*	R/(W)*	R/(W)*	R	R	R/W

Receive data register full
Status flag indicating that data has been received and stored in RDR

Overrun error
Status flag indicating detection of a receive overrun error

Framing error
Status flag indicating detection of a receive framing error

Parity error
Status flag indicating detection of a receive parity error

Transmit end
Status flag indicating end of transmission

Multiprocessor bit transfer
Value of multiprocessor bit to be transmitted

Multiprocessor bit
Stores the received multiprocessor bit value

Transmit data register empty
Status flag indicating that transmit data has been transferred from TDR into TSR and new data can be written in TDR

Note: * Only 0 can be written, to clear the flag.

The CPU can always read and write SSR, but cannot write 1 in the TDRE, RDRF, ORER, PER, and FER flags. These flags can be cleared to 0 only if they have first been read while set to 1. The TEND and MPB flags are read-only bits that cannot be written.

SSR is initialized to H'84 by a reset and in standby mode.

Bit 7—Transmit Data Register Empty (TDRE): Indicates that the SCI has loaded transmit data from TDR into TSR and the next serial transmit data can be written in TDR.

Bit 7 TDRE	Description
0	TDR contains valid transmit data [Clearing conditions] Software reads TDRE while it is set to 1, then writes 0.
1	TDR does not contain valid transmit data (Initial value) [Setting conditions] The chip is reset or enters standby mode. The TE bit in SCR is cleared to 0. TDR contents are loaded into TSR, so new data can be written in TDR.

Bit 6—Receive Data Register Full (RDRF): Indicates that RDR contains new receive data.

Bit 6 RDRF	Description
0	RDR does not contain new receive data (Initial value) [Clearing conditions] The chip is reset or enters standby mode. Software reads RDRF while it is set to 1, then writes 0. The DMAC reads data from RDR.
1	RDR contains new receive data [Setting condition] When serial data is received normally and transferred from RSR to RDR.

Note: The RDR contents and RDRF flag are not affected by detection of receive errors or by clearing of the RE bit to 0 in SCR. They retain their previous values. If the RDRF flag is still set to 1 when reception of the next data ends, an overrun error occurs and receive data is lost.

Bit 5—Overrun Error (ORER): Indicates that data reception ended abnormally due to an overrun error.

Bit 5

ORER	Description	
0	Receiving is in progress or has ended normally [Clearing conditions] The chip is reset or enters standby mode. Software reads ORER while it is set to 1, then writes 0.	(Initial value)*1
1	A receive overrun error occurred*2 [Setting condition] Reception of the next serial data ends when RDRF = 1.	

- Notes:
1. Clearing the RE bit to 0 in SCR does not affect the ORER flag, which retains its previous value.
 2. RDR continues to hold the receive data before the overrun error, so subsequent receive data is lost. Serial receiving cannot continue while the ORER flag is set to 1. In synchronous mode, serial transmitting is also disabled.

Bit 4—Framing Error (FER): Indicates that data reception ended abnormally due to a framing error in asynchronous mode.

Bit 4

FER	Description	
0	Receiving is in progress or has ended normally [Clearing conditions] The chip is reset or enters standby mode. Software reads FER while it is set to 1, then writes 0.	(Initial value)*1
1	A receive framing error occurred*2 [Setting condition] The stop bit at the end of receive data is checked and found to be 0.	

- Notes:
1. Clearing the RE bit to 0 in SCR does not affect the FER flag, which retains its previous value.
 2. When the stop bit length is 2 bits, only the first bit is checked. The second stop bit is not checked. When a framing error occurs the SCI transfers the receive data into RDR but does not set the RDRF flag. Serial receiving cannot continue while the FER flag is set to 1. In synchronous mode, serial transmitting is also disabled.

Bit 3—Parity Error (PER): Indicates that data reception ended abnormally due to a parity error in asynchronous mode.

Bit 3 PER	Description	
0	Receiving is in progress or has ended normally*1 [Clearing conditions] The chip is reset or enters standby mode. Software reads PER while it is set to 1, then writes 0.	(Initial value)
1	A receive parity error occurred*2 [Setting condition] The number of 1s in receive data, including the parity bit, does not match the even or odd parity setting of O/E in SMR.	

- Notes:
1. Clearing the RE bit to 0 in SCR does not affect the PER flag, which retains its previous value.
 2. When a parity error occurs the SCI transfers the receive data into RDR but does not set the RDRF flag. Serial receiving cannot continue while the PER flag is set to 1. In synchronous mode, serial transmitting is also disabled.

Bit 2—Transmit End (TEND): Indicates that when the last bit of a serial character was transmitted TDR did not contain new transmit data, so transmission has ended. The TEND flag is a read-only bit and cannot be written.

Bit 2 TEND	Description	
0	Transmission is in progress [Clearing conditions] Software reads TDRE while it is set to 1, then writes 0 in the TDRE flag.	
1	End of transmission [Setting conditions] The chip is reset or enters standby mode. The TE bit is cleared to 0 in SCR. TDRE is 1 when the last bit of a serial character is transmitted.	(Initial value)

Bit 1—Multiprocessor Bit (MPB): Stores the value of the multiprocessor bit in receive data when a multiprocessor format is used in asynchronous mode. MPB is a read-only bit and cannot be written.

Bit 1

MPB	Description
0	Multiprocessor bit value in receive data is 0* (Initial value)
1	Multiprocessor bit value in receive data is 1

Note: * If the RE bit is cleared to 0 when a multiprocessor format is selected, MPB retains its previous value.

Bit 0—Multiprocessor Bit Transfer (MPBT): Stores the value of the multiprocessor bit added to transmit data when a multiprocessor format is selected for transmitting in asynchronous mode. The MPBT setting is ignored in synchronous mode, when a multiprocessor format is not selected, or when the SCI is not transmitting.

Bit 0

MPBT	Description
0	Multiprocessor bit value in transmit data is 0 (Initial value)
1	Multiprocessor bit value in transmit data is 1

10.2.8 Bit Rate Register (BRR)

BRR is an 8-bit register that, together with the CKS1 and CKS0 bits in SMR that select the baud rate generator clock source, determines the serial communication bit rate.

Bit	7	6	5	4	3	2	1	0
Initial value	1	1	1	1	1	1	1	1
Read/Write	R/W	R/W	R/W	R/W	R/W	R/W	R/W	R/W

The CPU can always read and write BRR. BRR is initialized to H'FF by a reset and in standby mode. The two SCI channels have independent baud rate generator control, so different values can be set in the two channels.

Table 10-3 shows examples of BRR settings in asynchronous mode. Table 10-4 shows examples of BRR settings in synchronous mode.

Table 10-3 Examples of Bit Rates and BRR Settings in Asynchronous Mode

Bit Rate (bits/s)	ϕ (MHz)											
	2			2.097152			2.4576			3		
	n	N	Error (%)	n	N	Error (%)	n	N	Error (%)	n	N	Error (%)
110	1	141	0.03	1	148	-0.04	1	174	-0.26	1	212	0.03
150	1	103	0.16	1	108	0.21	1	127	0	1	155	0.16
300	0	207	0.16	0	217	0.21	0	255	0	1	77	0.16
600	0	103	0.16	0	108	0.21	0	127	0	0	155	0.16
1200	0	51	0.16	0	54	-0.70	0	63	0	0	77	0.16
2400	0	25	0.16	0	26	1.14	0	31	0	0	38	0.16
4800	0	12	0.16	0	13	-2.48	0	15	0	0	19	-2.34
9600	0	6	-6.99	0	6	-2.48	0	7	0	0	9	-2.34
19200	0	2	8.51	0	2	13.78	0	3	0	0	4	-2.34
31250	0	1	0	0	1	4.86	0	1	22.88	0	2	0
38400	0	1	-18.62	0	1	-14.67	0	1	0	—	—	—

Bit Rate (bits/s)	ϕ (MHz)											
	3.6864			4			4.9152			5		
	n	N	Error (%)	n	N	Error (%)	n	N	Error (%)	n	N	Error (%)
110	2	64	0.70	2	70	0.03	2	86	0.31	2	88	-0.25
150	1	191	0	1	207	0.16	1	255	0	2	64	0.16
300	1	95	0	1	103	0.16	1	127	0	1	129	0.16
600	0	191	0	0	207	0.16	0	255	0	1	64	0.16
1200	0	95	0	0	103	0.16	0	127	0	0	129	0.16
2400	0	47	0	0	51	0.16	0	63	0	0	64	0.16
4800	0	23	0	0	25	0.16	0	31	0	0	32	-1.36
9600	0	11	0	0	12	0.16	0	15	0	0	15	1.73
19200	0	5	0	0	6	-6.99	0	7	0	0	7	1.73
31250	—	—	—	0	3	0	0	4	-1.70	0	4	0
38400	0	2	0	0	2	8.51	0	3	0	0	3	1.73

Table 10-3 Examples of Bit Rates and BRR Settings in Asynchronous Mode (cont)

Bit Rate (bits/s)	ϕ (MHz)											
	6			6.144			7.3728			8		
	n	N	Error (%)	n	N	Error (%)	n	N	Error (%)	n	N	Error (%)
110	2	106	-0.44	2	108	0.08	2	130	-0.07	2	141	0.03
150	2	77	0.16	2	79	0	2	95	0	2	103	0.16
300	1	155	0.16	1	159	0	1	191	0	1	207	0.16
600	1	77	0.16	1	79	0	1	95	0	1	103	0.16
1200	0	155	0.16	0	159	0	0	191	0	0	207	0.16
2400	0	77	0.16	0	79	0	0	95	0	0	103	0.16
4800	0	38	0.16	0	39	0	0	47	0	0	51	0.16
9600	0	19	-2.34	0	19	0	0	23	0	0	25	0.16
19200	0	9	-2.34	0	9	0	0	11	0	0	12	0.16
31250	0	5	0	0	5	2.40	0	6	5.33	0	7	0
38400	0	4	-2.34	0	4	0	0	5	0	0	6	-6.99

Bit Rate (bits/s)	ϕ (MHz)											
	9.8304			10			12			12.288		
	n	N	Error (%)	n	N	Error (%)	n	N	Error (%)	n	N	Error (%)
110	2	174	-0.26	2	177	-0.25	2	212	0.03	2	217	0.08
150	2	127	0	2	129	0.16	2	155	0.16	2	159	0
300	1	255	0	2	64	0.16	2	77	0.16	2	79	0
600	1	127	0	1	129	0.16	1	155	0.16	1	159	0
1200	0	255	0	1	64	0.16	1	77	0.16	1	79	0
2400	0	127	0	0	129	0.16	0	155	0.16	0	159	0
4800	0	63	0	0	64	0.16	0	77	0.16	0	79	0
9600	0	31	0	0	32	-1.36	0	38	0.16	0	39	0
19200	0	15	0	0	15	1.73	0	19	-2.34	0	19	0
31250	0	9	-1.70	0	9	0	0	11	0	0	11	2.40
38400	0	7	0	0	7	1.73	0	9	-2.34	0	9	0

Table 10-3 Examples of Bit Rates and BRR Settings in Asynchronous Mode (cont)

Bit Rate (bits/s)	ϕ (MHz)								
	14			14.7456			16		
	n	N	Error (%)	n	N	Error (%)	n	N	Error (%)
110	2	248	-0.17	3	64	0.70	3	70	0.03
150	2	181	0.16	2	191	0	2	207	0.16
300	2	90	0.16	2	95	0	2	103	0.16
600	1	181	0.16	1	191	0	1	207	0.16
1200	1	90	0.16	1	95	0	1	103	0.16
2400	0	181	0.16	0	191	0	0	207	0.16
4800	0	90	0.16	0	95	0	0	103	0.16
9600	0	45	-0.93	0	47	0	0	51	0.16
19200	0	22	-0.93	0	23	0	0	25	0.16
31250	0	13	0	0	14	-1.70	0	15	0
38400	0	10	3.57	0	11	0	0	12	0.16

Table 10-4 Examples of Bit Rates and BRR Settings in Synchronous Mode

Bit Rate (bits/s)	ø (MHz)									
	2		4		8		10		16	
	n	N	n	N	n	N	n	N	n	N
110	3	70	—	—	—	—	—	—	—	—
250	2	124	2	249	3	124	—	—	3	249
500	1	249	2	124	2	249	—	—	3	124
1 k	1	124	1	249	2	124	—	—	2	249
2.5 k	0	199	1	99	1	199	1	249	2	99
5 k	0	99	0	199	1	99	1	124	1	199
10 k	0	49	0	99	0	199	0	249	1	99
25 k	0	19	0	39	0	79	0	99	0	159
50 k	0	9	0	19	0	39	0	49	0	79
100 k	0	4	0	9	0	19	0	24	0	39
250 k	0	1	0	3	0	7	0	9	0	15
500 k	0	0*	0	1	0	3	0	4	0	7
1 M			0	0*	0	1	—	—	0	3
2 M					0	0*	—	—	0	1
2.5 M					—	—	0	0*	—	—
5 M									0	0*

Note: Settings with an error of 1% or less are recommended.

Legend

Blank: No setting available

—: Setting possible, but error occurs

*: Continuous transmit/receive not possible

The BRR setting is calculated as follows:

Asynchronous mode:

$$N = \frac{\varnothing}{64 \times 2^{2n-1} \times B} \times 10^6 - 1$$

Synchronous mode:

$$N = \frac{\varnothing}{8 \times 2^{2n-1} \times B} \times 10^6 - 1$$

B: Bit rate (bits/s)

N: BRR setting for baud rate generator (0 ≤ N ≤ 255)

ø: System clock frequency (MHz)

n: Baud rate generator clock source (n = 0, 1, 2, 3)

(For the clock sources and values of n, see the table below.)

n	Clock Source	SMR Settings	
		CKS1	CKS0
0	\emptyset	0	0
1	$\emptyset/4$	0	1
2	$\emptyset/16$	1	0
3	$\emptyset/64$	1	1

The bit rate error in asynchronous mode is calculated as follows.

$$\text{Error (\%)} = \left\{ \frac{\emptyset \times 10^6}{(N + 1) \times B \times 64 \times 2^{2n-1}} - 1 \right\} \times 100$$

Table 10-5 indicates the maximum bit rates in asynchronous mode for various system clock frequencies. Tables 10-6 and 10-7 indicate the maximum bit rates with external clock input.

Table 10-5 Maximum Bit Rates for Various Frequencies (Asynchronous Mode)

ϕ (MHz)	Maximum Bit Rate (bits/s)	Settings	
		n	N
2	62500	0	0
2.097152	65536	0	0
2.4576	76800	0	0
3	93750	0	0
3.6864	115200	0	0
4	125000	0	0
4.9152	153600	0	0
5	156250	0	0
6	187500	0	0
6.144	192000	0	0
7.3728	230400	0	0
8	250000	0	0
9.8304	307200	0	0
10	312500	0	0
12	375000	0	0
12.288	384000	0	0
14	437500	0	0
14.7456	460800	0	0
16	500000	0	0

Table 10-6 Maximum Bit Rates with External Clock Input (Asynchronous Mode)

ø (MHz)	External Input Clock (MHz)	Maximum Bit Rate (bits/s)
2	0.5000	31250
2.097152	0.5243	32768
2.4576	0.6144	38400
3	0.7500	46875
3.6864	0.9216	57600
4	1.0000	62500
4.9152	1.2288	76800
5	1.2500	78125
6	1.5000	93750
6.144	1.5360	96000
7.3728	1.8432	115200
8	2.0000	125000
9.8304	2.4576	153600
10	2.5000	156250
12	3.0000	187500
12.288	3.0720	192000
14	3.5000	218750
14.7456	3.6864	230400
16	4.0000	250000

Table 10-7 Maximum Bit Rates with External Clock Input (Synchronous Mode)

ø (MHz)	External Input Clock (MHz)	Maximum Bit Rate (bits/s)
2	0.3333	333333.3
4	0.6667	666666.7
6	1.0000	1000000.0
8	1.3333	1333333.3
10	1.6667	1666666.7
12	2.0000	2000000.0
14	2.3333	2333333.3
16	2.6667	2666666.7

10.3 Operation

10.3.1 Overview

The SCI has an asynchronous mode in which characters are synchronized individually, and a synchronous mode in which communication is synchronized with clock pulses. Serial communication is possible in either mode. Asynchronous or synchronous mode and the communication format are selected in SMR, as shown in table 10-8. The SCI clock source is selected by the C/\overline{A} bit in SMR and the CKE1 and CKE0 bits in SCR, as shown in table 10-9.

Asynchronous Mode

- Data length is selectable: 7 or 8 bits.
- Parity and multiprocessor bits are selectable. So is the stop bit length (1 or 2 bits). These selections determine the communication format and character length.
- In receiving, it is possible to detect framing errors, parity errors, overrun errors, and the break state.
- An internal or external clock can be selected as the SCI clock source.
 - When an internal clock is selected, the SCI operates using the on-chip baud rate generator, and can output a serial clock signal with a frequency matching the bit rate.
 - When an external clock is selected, the external clock input must have a frequency 16 times the bit rate. (The on-chip baud rate generator is not used.)

Synchronous Mode

- The communication format has a fixed 8-bit data length.
- In receiving, it is possible to detect overrun errors.
- An internal or external clock can be selected as the SCI clock source.
 - When an internal clock is selected, the SCI operates using the on-chip baud rate generator, and outputs a serial clock signal to external devices.
 - When an external clock is selected, the SCI operates on the input serial clock. The on-chip baud rate generator is not used.

Table 10-8 SMR Settings and Serial Communication Formats

SMR Settings					SCI Communication Format				
Bit 7 C/A	Bit 6 CHR	Bit 2 MP	Bit 5 PE	Bit 3 STOP	Mode	Data Length	Multi-processor Bit	Parity Bit	Stop Bit Length
0	0	0	0	0	Asynchronous mode	8-bit data	Absent	Absent	1 bit
0	0	0	0	1					2 bits
0	0	0	1	0					1 bit
0	0	0	1	1					2 bits
0	1	0	0	0		7-bit data	Absent	Absent	1 bit
0	1	0	0	1					2 bits
0	1	0	1	0					1 bit
0	1	0	1	1					2 bits
0	0	1	—	0	Asynchronous mode (multi-processor format)	8-bit data	Present	Absent	1 bit
0	0	1	—	1					2 bits
0	1	1	—	0		7-bit data			1 bit
0	1	1	—	1					2 bits
1	—	—	—	—	Synchronous mode	8-bit data	Absent		None

Table 10-9 SMR and SCR Settings and SCI Clock Source Selection

SMR		SCR Settings		SCI Transmit/Receive Clock		
Bit 7 C/A	Bit 1 CKE1	Bit 0 CKE0	Mode	Clock Source	SCK Pin Function	
0	0	0	Asynchronous mode	Internal	SCI does not use the SCK pin	
0	0	1			Outputs a clock with frequency matching the bit rate	
0	1	0		External	Inputs a clock with frequency 16 times the bit rate	
0	1	1				
1	0	0	Synchronous mode	Internal	Outputs the serial clock	
1	0	1				
1	1	0		External	Inputs the serial clock	
1	1	1				

10.3.2 Operation in Asynchronous Mode

In asynchronous mode each transmitted or received character begins with a start bit and ends with a stop bit. Serial communication is synchronized one character at a time.

The transmitting and receiving sections of the SCI are independent, so full duplex communication is possible. The transmitter and receiver are both double buffered, so data can be written and read while transmitting and receiving are in progress, enabling continuous transmitting and receiving.

Figure 10-2 shows the general format of asynchronous serial communication. In asynchronous serial communication the communication line is normally held in the mark (high) state. The SCI monitors the line and starts serial communication when the line goes to the space (low) state, indicating a start bit. One serial character consists of a start bit (low), data (LSB first), parity bit (high or low), and stop bit (high), in that order.

When receiving in asynchronous mode, the SCI synchronizes at the falling edge of the start bit. The SCI samples each data bit on the eighth pulse of a clock with a frequency 16 times the bit rate. Receive data is latched at the center of each bit.

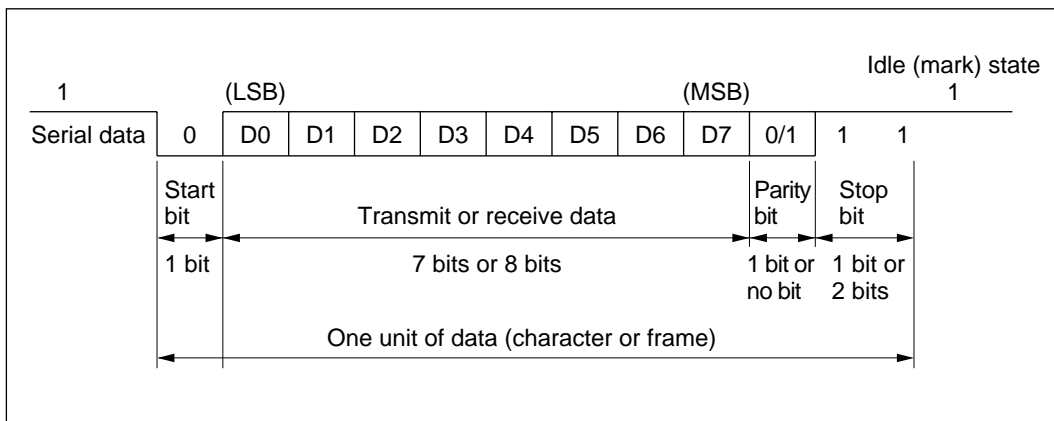

Figure 10-2 Data Format in Asynchronous Communication (Example: 8-Bit Data with Parity and 2 Stop Bits)

Communication Formats: Table 10-10 shows the 12 communication formats that can be selected in asynchronous mode. The format is selected by settings in SMR.

Table 10-10 Serial Communication Formats (Asynchronous Mode)

SMR Settings				Serial Communication Format and Frame Length												
CHR	PE	MP	STOP	1	2	3	4	5	6	7	8	9	10	11	12	
0	0	0	0	S	8-bit data								STOP			
0	0	0	1	S	8-bit data								STOP	STOP		
0	1	0	0	S	8-bit data								P	STOP		
0	1	0	1	S	8-bit data								P	STOP	STOP	
1	0	0	0	S	7-bit data							STOP				
1	0	0	1	S	7-bit data							STOP	STOP			
1	1	0	0	S	7-bit data							P	STOP			
1	1	0	1	S	7-bit data							P	STOP	STOP		
0	—	1	0	S	8 bit data								MPB	STOP		
0	—	1	1	S	8 bit data								MPB	STOP	STOP	
1	—	1	0	S	7-bit data							MPB	STOP			
1	—	1	1	S	7-bit data							MPB	STOP	STOP		

Legend

- S: Start bit
- STOP: Stop bit
- P: Parity bit
- MPB: Multiprocessor bit

Clock: An internal clock generated by the on-chip baud rate generator or an external clock input from the SCK pin can be selected as the SCI transmit/receive clock. The clock source is selected by the C/\bar{A} bit in SMR and bits CKE1 and CKE0 in SCR. See table 10-9.

When an external clock is input at the SCK pin, it must have a frequency equal to 16 times the desired bit rate.

When the SCI operates on an internal clock, it can output a clock signal at the SCK pin. The frequency of this output clock is equal to the bit rate. The phase is aligned as in figure 10-3 so that the rising edge of the clock occurs at the center of each transmit data bit.

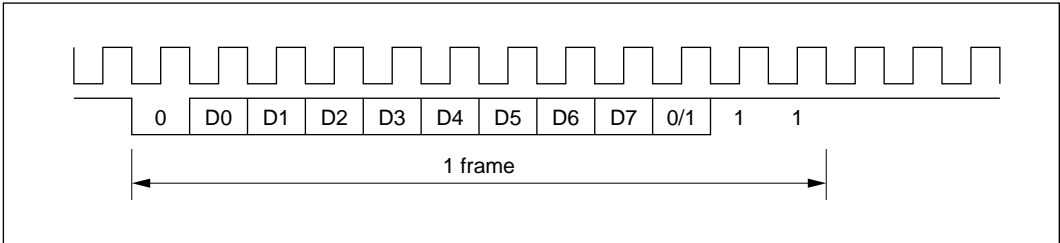

Figure 10-3 Phase Relationship between Output Clock and Serial Data (Asynchronous Mode)

Transmitting and Receiving Data

SCI Initialization (Asynchronous Mode): Before transmitting or receiving, clear the TE and RE bits to 0 in SCR, then initialize the SCI as follows.

When changing the communication mode or format, always clear the TE and RE bits to 0 before following the procedure given below. Clearing TE to 0 sets the TDRE flag to 1 and initializes TSR. Clearing RE to 0, however, does not initialize the RDRF, PER, FER, and ORER flags and RDR, which retain their previous contents.

When an external clock is used, the clock should not be stopped during initialization or subsequent operation. SCI operation becomes unreliable if the clock is stopped.

Figure 10-4 is a sample flowchart for initializing the SCI.

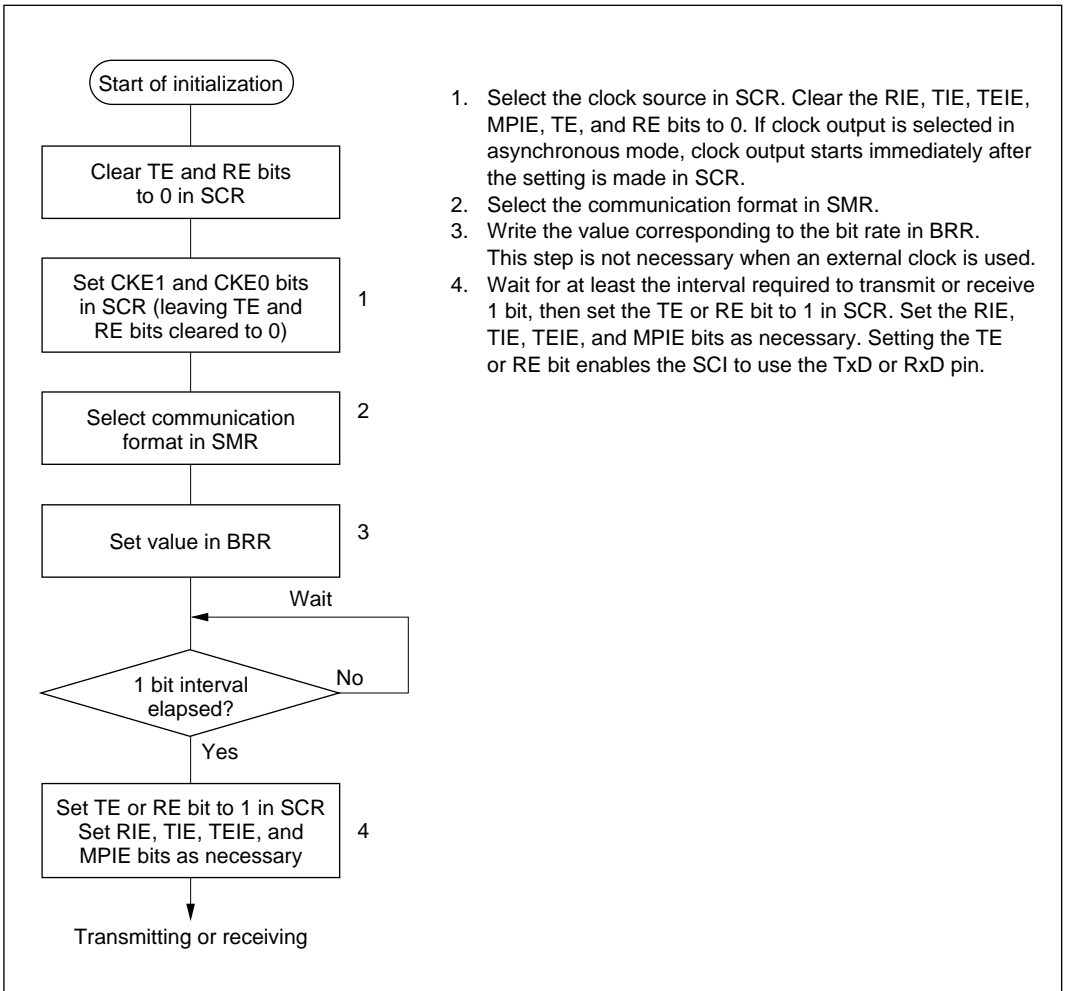

Figure 10-4 Sample Flowchart for SCI Initialization

Transmitting Serial Data (Asynchronous Mode): Figure 10-5 shows a sample flowchart for transmitting serial data and indicates the procedure to follow.

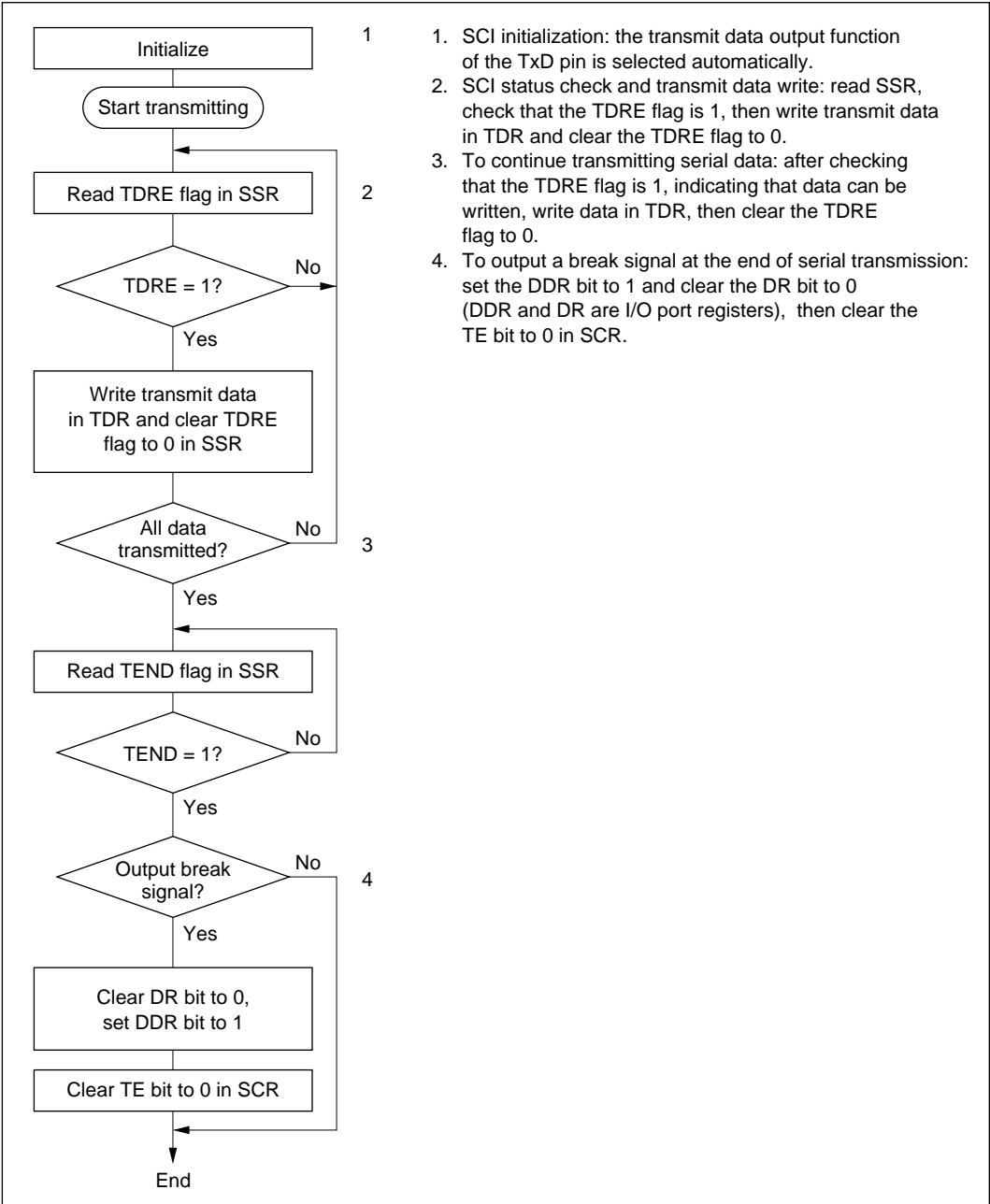

Figure 10-5 Sample Flowchart for Transmitting Serial Data

In transmitting serial data, the SCI operates as follows.

- The SCI monitors the TDRE flag in SSR. When the TDRE flag is cleared to 0 the SCI recognizes that TDR contains new data, and loads this data from TDR into TSR.
- After loading the data from TDR into TSR, the SCI sets the TDRE flag to 1 and starts transmitting. If the TIE bit is set to 1 in SCR, the SCI requests a transmit-data-empty interrupt (TXI) at this time.

Serial transmit data is transmitted in the following order from the TxD pin:

- Start bit: One 0 bit is output.
- Transmit data: 7 or 8 bits are output, LSB first.
- Parity bit or multiprocessor bit: One parity bit (even or odd parity) or one multiprocessor bit is output. Formats in which neither a parity bit nor a multiprocessor bit is output can also be selected.
- Stop bit: One or two 1 bits (stop bits) are output.
- Mark state: Output of 1 bits continues until the start bit of the next transmit data.

- The SCI checks the TDRE flag when it outputs the stop bit. If the TDRE flag is 0, the SCI loads new data from TDR into TSR, outputs the stop bit, then begins serial transmission of the next frame. If the TDRE flag is 1, the SCI sets the TEND flag to 1 in SSR, outputs the stop bit, then continues output of 1 bits in the mark state. If the TEIE bit is set to 1 in SCR, a transmit-end interrupt (TEI) is requested at this time.

Figure 10-6 shows an example of SCI transmit operation in asynchronous mode.

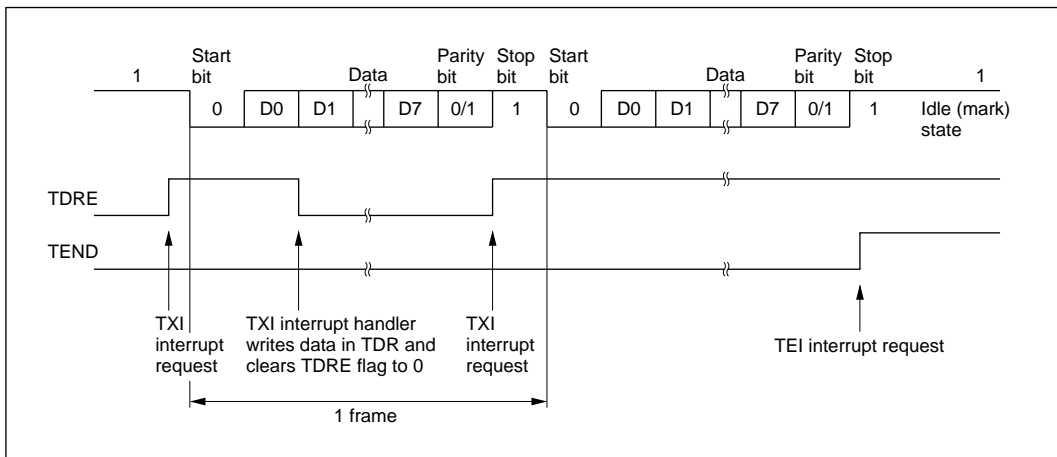
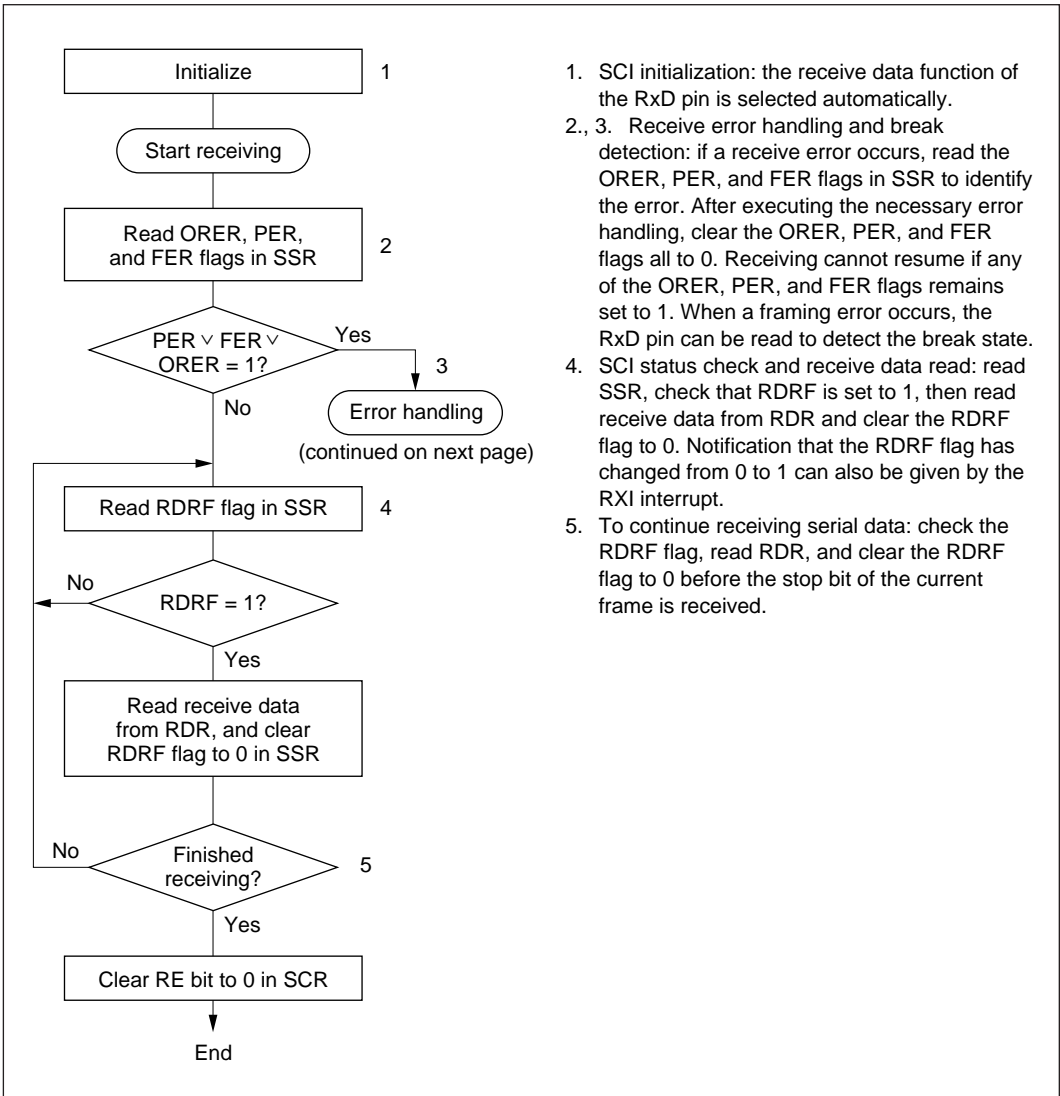

Figure 10-6 Example of SCI Transmit Operation in Asynchronous Mode (8-Bit Data with Parity and 1 Stop Bit)

Receiving Serial Data (Asynchronous Mode): Figure 10-7 shows a sample flowchart for receiving serial data and indicates the procedure to follow.



1. SCI initialization: the receive data function of the RxD pin is selected automatically.
- 2., 3. Receive error handling and break detection: if a receive error occurs, read the ORER, PER, and FER flags in SSR to identify the error. After executing the necessary error handling, clear the ORER, PER, and FER flags all to 0. Receiving cannot resume if any of the ORER, PER, and FER flags remains set to 1. When a framing error occurs, the RxD pin can be read to detect the break state.
4. SCI status check and receive data read: read SSR, check that RDRF is set to 1, then read receive data from RDR and clear the RDRF flag to 0. Notification that the RDRF flag has changed from 0 to 1 can also be given by the RXI interrupt.
5. To continue receiving serial data: check the RDRF flag, read RDR, and clear the RDRF flag to 0 before the stop bit of the current frame is received.

Figure 10-7 Sample Flowchart for Receiving Serial Data (1)

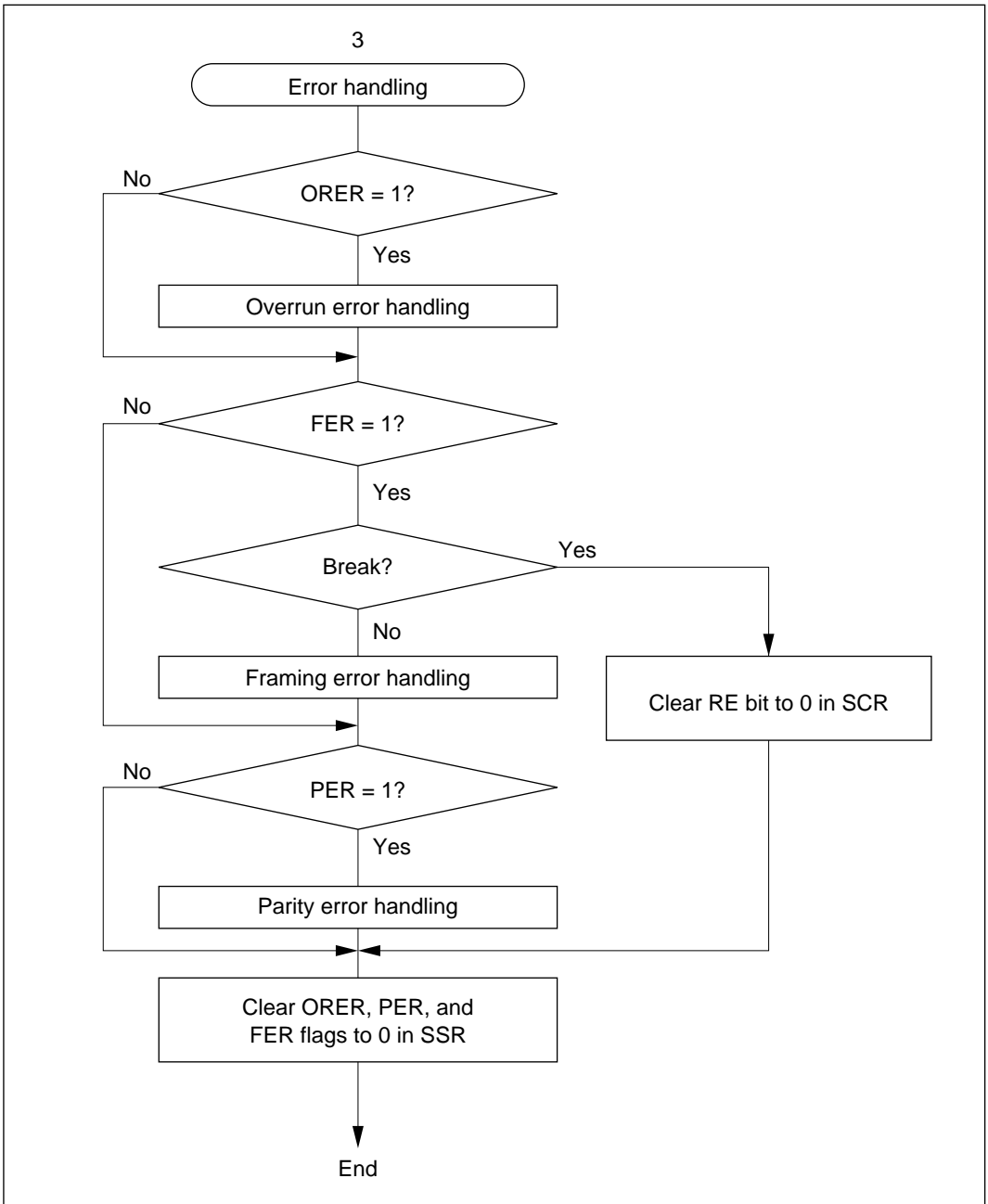

Figure 10-7 Sample Flowchart for Receiving Serial Data (2)

In receiving, the SCI operates as follows.

- The SCI monitors the receive data line. When it detects a start bit, the SCI synchronizes internally and starts receiving.
- Receive data is stored in RSR in order from LSB to MSB.
- The parity bit and stop bit are received.

After receiving, the SCI makes the following checks:

- Parity check: The number of 1s in the receive data must match the even or odd parity setting of the O/\bar{E} bit in SMR.
- Stop bit check: The stop bit value must be 1. If there are two stop bits, only the first stop bit is checked.
- Status check: The RDRF flag must be 0 so that receive data can be transferred from RSR into RDR.

If these checks all pass, the RDRF flag is set to 1 and the received data is stored in RDR. If one of the checks fails (receive error), the SCI operates as indicated in table 10-11.

Note: When a receive error occurs, further receiving is disabled. In receiving, the RDRF flag is not set to 1. Be sure to clear the error flags.

- When the RDRF flag is set to 1, if the RIE bit is set to 1 in SCR, a receive-data-full interrupt (RXI) is requested. If the ORER, PER, or FER flag is set to 1 and the RIE bit in SCR is also set to 1, a receive-error interrupt (ERI) is requested.

Table 10-11 Receive Error Conditions

Receive Error	Abbreviation	Condition	Data Transfer
Overrun error	ORER	Receiving of next data ends while RDRF flag is still set to 1 in SSR	Receive data not transferred from RSR to RDR
Framing error	FER	Stop bit is 0	Receive data transferred from RSR to RDR
Parity error	PER	Parity of receive data differs from even/odd parity setting in SMR	Receive data transferred from RSR to RDR

Figure 10-8 shows an example of SCI receive operation in asynchronous mode.

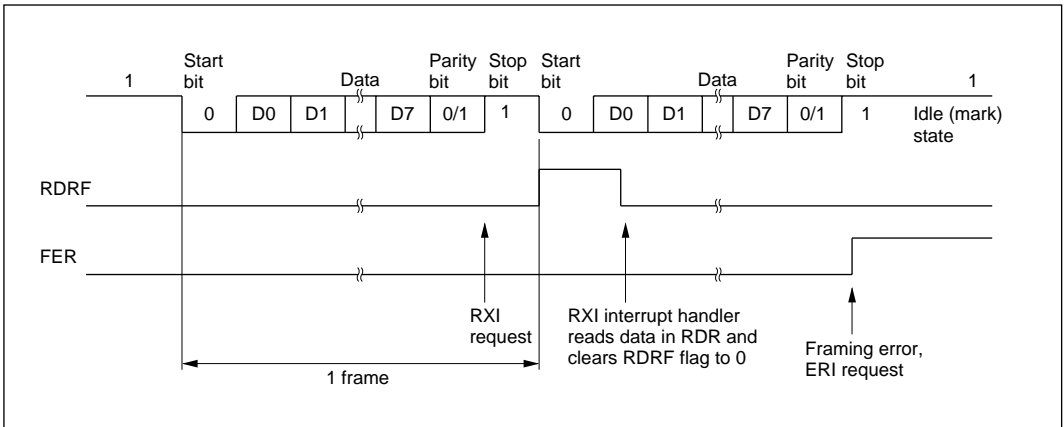

Figure 10-8 Example of SCI Receive Operation (8-Bit Data with Parity and One Stop Bit)

10.3.3 Multiprocessor Communication

The multiprocessor communication function enables several processors to share a single serial communication line. The processors communicate in asynchronous mode using a format with an additional multiprocessor bit (multiprocessor format).

In multiprocessor communication, each receiving processor is addressed by an ID. A serial communication cycle consists of an ID-sending cycle that identifies the receiving processor, and a data-sending cycle. The multiprocessor bit distinguishes ID-sending cycles from data-sending cycles.

The transmitting processor starts by sending the ID of the receiving processor with which it wants to communicate as data with the multiprocessor bit set to 1. Next the transmitting processor sends transmit data with the multiprocessor bit cleared to 0.

Receiving processors skip incoming data until they receive data with the multiprocessor bit set to 1. When they receive data with the multiprocessor bit set to 1, receiving processors compare the data with their IDs. The receiving processor with a matching ID continues to receive further incoming data. Processors with IDs not matching the received data skip further incoming data until they again receive data with the multiprocessor bit set to 1. Multiple processors can send and receive data in this way.

Figure 10-9 shows an example of communication among different processors using a multiprocessor format.

Communication Formats: Four formats are available. Parity-bit settings are ignored when a multiprocessor format is selected. For details see table 10-8.

Clock: See the description of asynchronous mode.

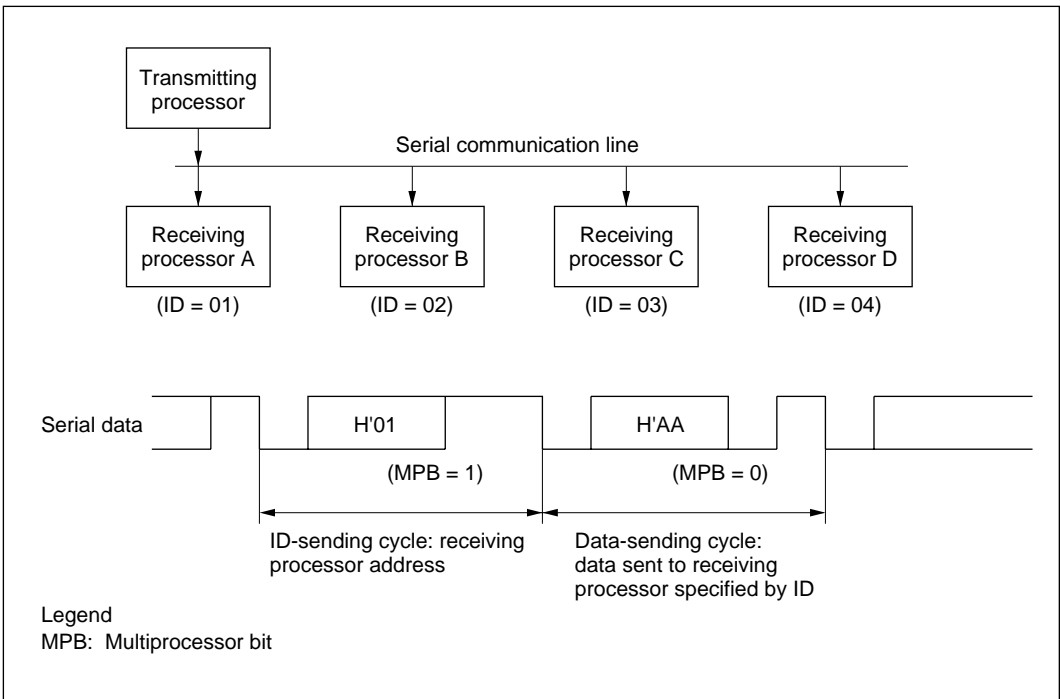

Figure 10-9 Example of Communication among Processors using Multiprocessor Format (Sending Data H'AA to Receiving Processor A)

Transmitting and Receiving Data

Transmitting Multiprocessor Serial Data: Figure 10-10 shows a sample flowchart for transmitting multiprocessor serial data and indicates the procedure to follow.

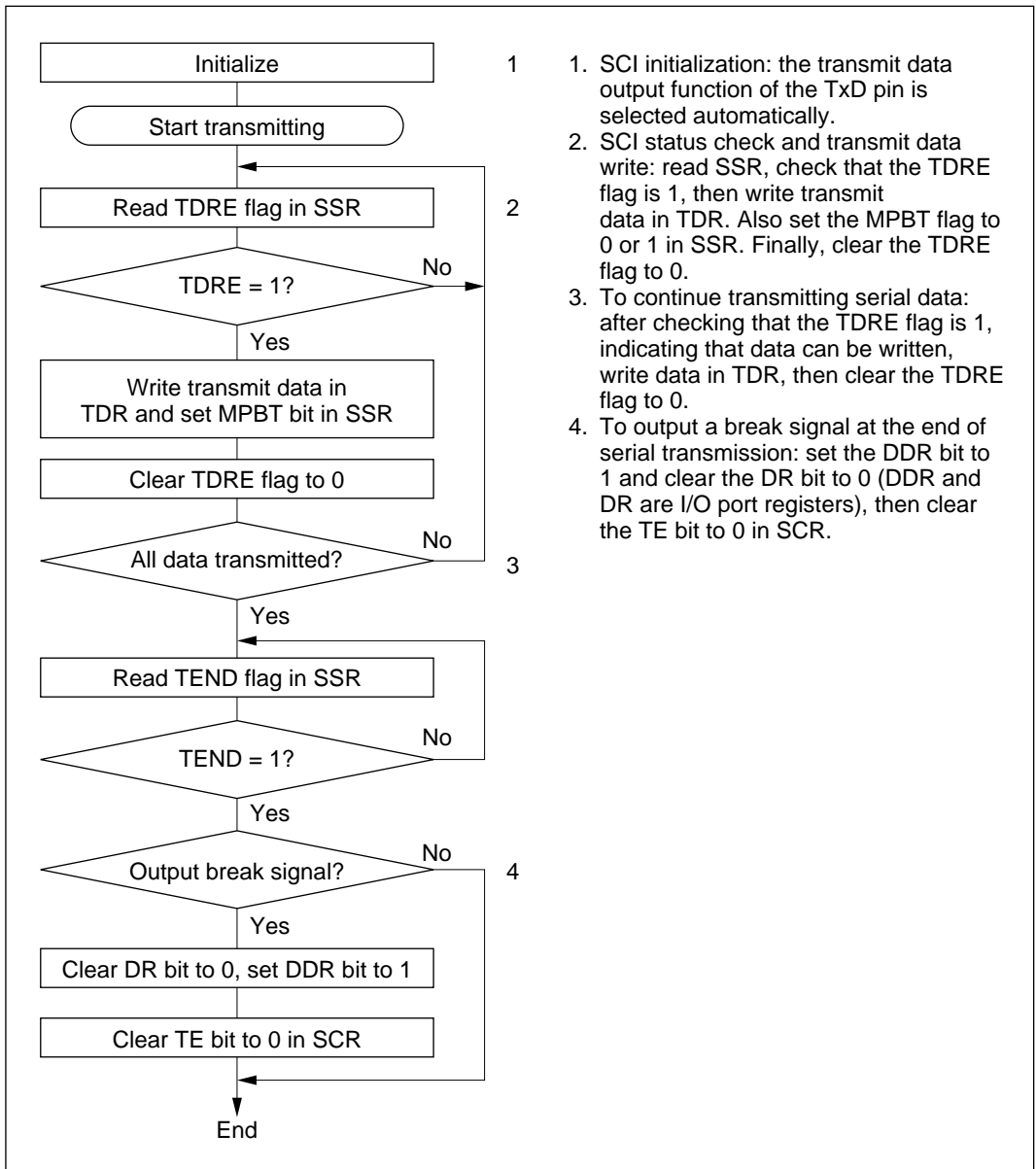

Figure 10-10 Sample Flowchart for Transmitting Multiprocessor Serial Data

In transmitting serial data, the SCI operates as follows.

- The SCI monitors the TDRE flag in SSR. When the TDRE flag is cleared to 0 the SCI recognizes that TDR contains new data, and loads this data from TDR into TSR.
- After loading the data from TDR into TSR, the SCI sets the TDRE flag to 1 and starts transmitting. If the TIE bit in SCR is set to 1, the SCI requests a transmit-data-empty interrupt (TXI) at this time.

Serial transmit data is transmitted in the following order from the TxD pin:

- Start bit: One 0 bit is output.
 - Transmit data: 7 or 8 bits are output, LSB first.
 - Multiprocessor bit: One multiprocessor bit (MPBT value) is output.
 - Stop bit: One or two 1 bits (stop bits) are output.
 - Mark state: Output of 1 bits continues until the start bit of the next transmit data.
- The SCI checks the TDRE flag when it outputs the stop bit. If the TDRE flag is 0, the SCI loads data from TDR into TSR, outputs the stop bit, then begins serial transmission of the next frame. If the TDRE flag is 1, the SCI sets the TEND flag in SSR to 1, outputs the stop bit, then continues output of 1 bits in the mark state. If the TEIE bit is set to 1 in SCR, a transmit-end interrupt (TEI) is requested at this time.

Figure 10-11 shows an example of SCI transmit operation using a multiprocessor format.

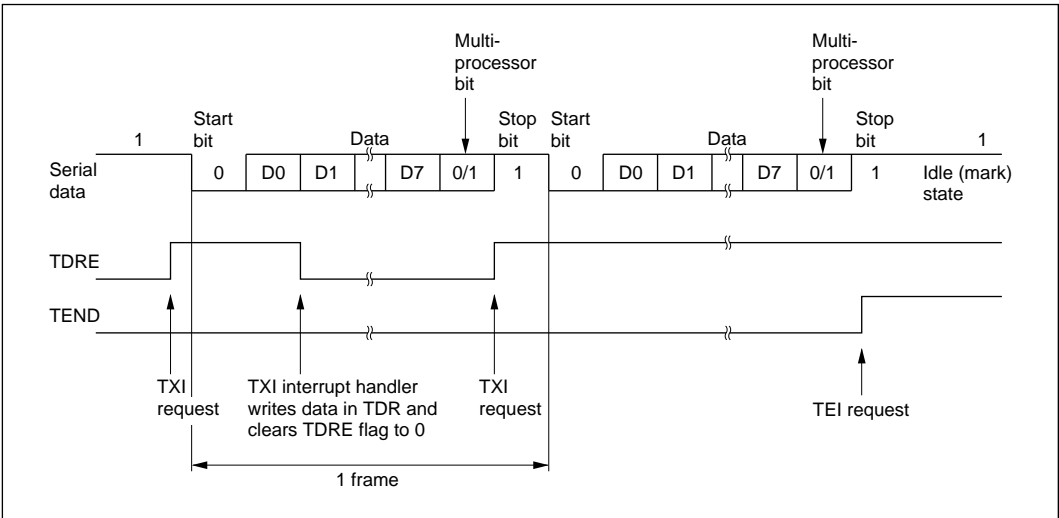

Figure 10-11 Example of SCI Transmit Operation (8-Bit Data with Multiprocessor Bit and One Stop Bit)

Receiving Multiprocessor Serial Data: Figure 10-12 shows a sample flowchart for receiving multiprocessor serial data and indicates the procedure to follow.

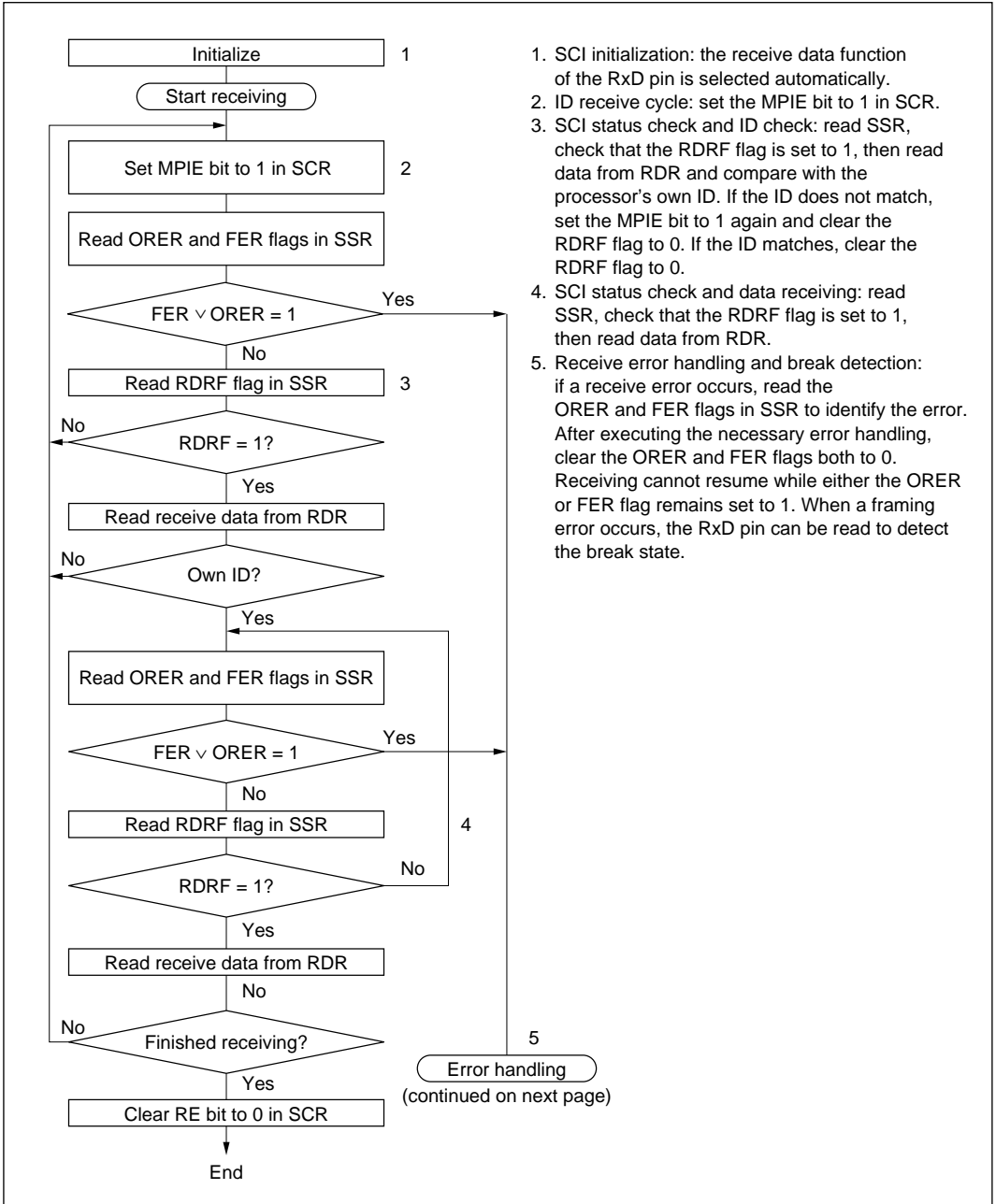

Figure 10-12 Sample Flowchart for Receiving Multiprocessor Serial Data (1)

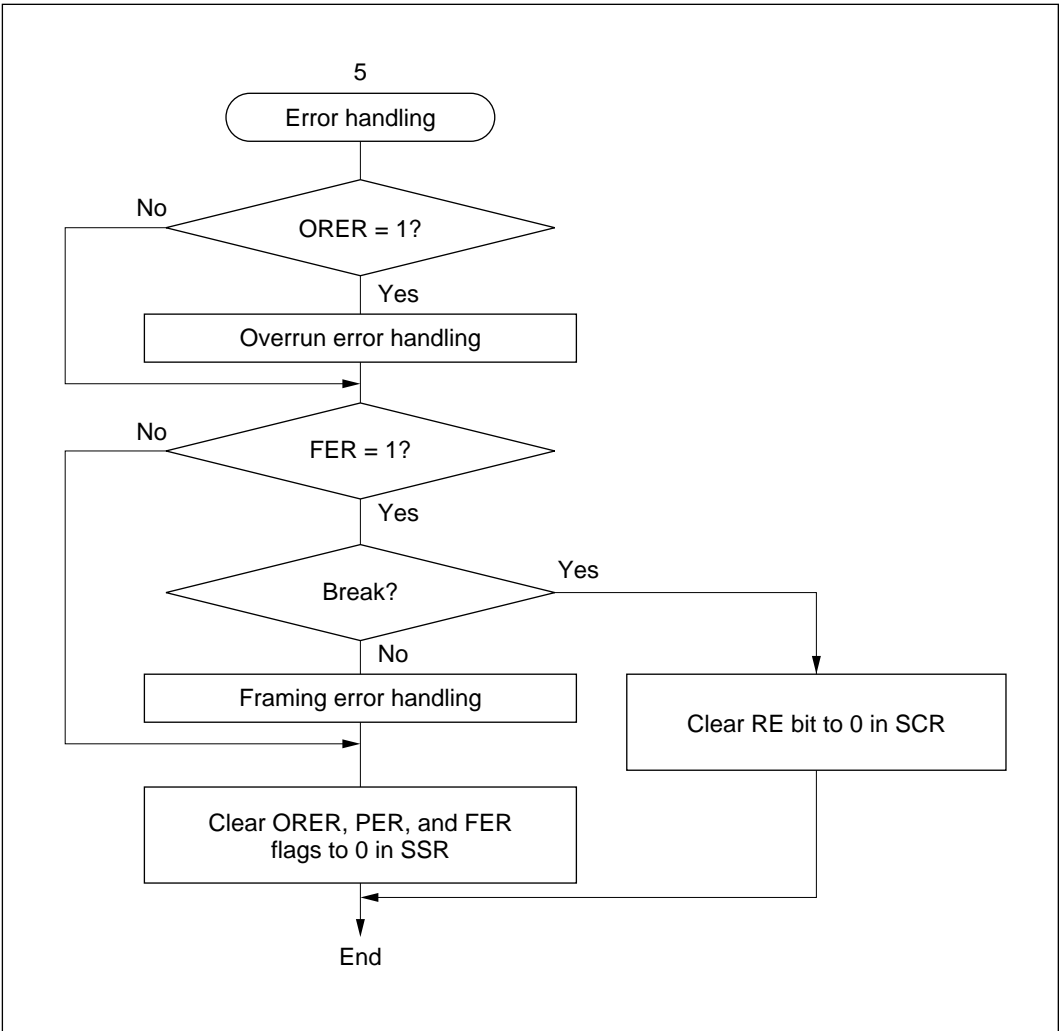

Figure 10-12 Sample Flowchart for Receiving Multiprocessor Serial Data (2)

Figure 10-13 shows an example of SCI receive operation using a multiprocessor format.

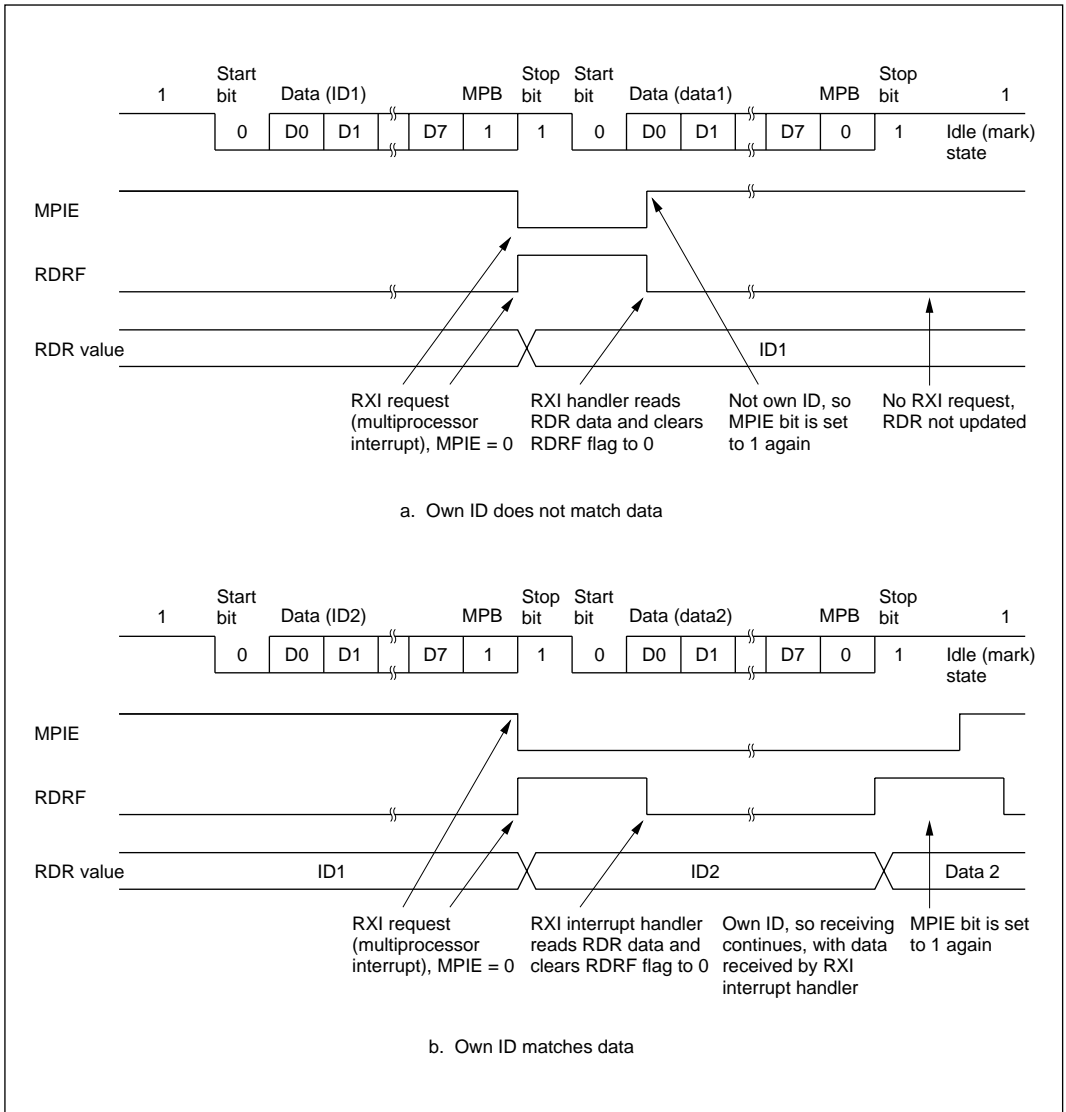

Figure 10-13 Example of SCI Receive Operation (8-Bit Data with Multiprocessor Bit and One Stop Bit)

10.3.4 Synchronous Operation

In synchronous mode, the SCI transmits and receives data in synchronization with clock pulses. This mode is suitable for high-speed serial communication.

The SCI transmitter and receiver share the same clock but are otherwise independent, so full duplex communication is possible. The transmitter and receiver are also double buffered, so continuous transmitting or receiving is possible by reading or writing data while transmitting or receiving is in progress.

Figure 10-14 shows the general format in synchronous serial communication.

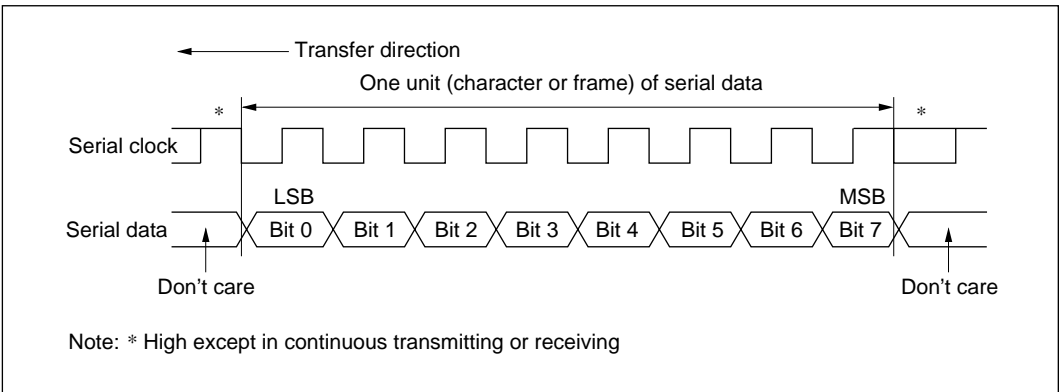

Figure 10-14 Data Format in Synchronous Communication

In synchronous serial communication, each data bit is placed on the communication line from one falling edge of the serial clock to the next. Data is guaranteed valid at the rise of the serial clock. In each character, the serial data bits are transmitted in order from LSB (first) to MSB (last). After output of the MSB, the communication line remains in the state of the MSB. In synchronous mode the SCI receives data by synchronizing with the rise of the serial clock.

Communication Format: The data length is fixed at 8 bits. No parity bit or multiprocessor bit can be added.

Clock: An internal clock generated by the on-chip baud rate generator or an external clock input from the SCK pin can be selected by clearing or setting the CKE1 bit in SCR. See table 10-9. When the SCI operates on an internal clock, it outputs the clock signal at the SCK pin. Eight clock pulses are output per transmitted or received character. When the SCI is not transmitting or receiving, the clock signal remains in the high state. When the SCI is only receiving, it receives in units of two characters, so it outputs 16 clock pulses. To receive in units of one character, an external clock source must be selected.

Transmitting and Receiving Data

SCI Initialization (Synchronous Mode): Before transmitting or receiving, clear the TE and RE bits to 0 in SCR, then initialize the SCI as follows.

When changing the communication mode or format, always clear the TE and RE bits to 0 before following the procedure given below. Clearing the TE bit to 0 sets the TDRE flag to 1 and initializes TSR. Clearing the RE bit to 0, however, does not initialize the RDRF, PER, FER, and ORE flags and RDR, which retain their previous contents.

Figure 10-15 is a sample flowchart for initializing the SCI.

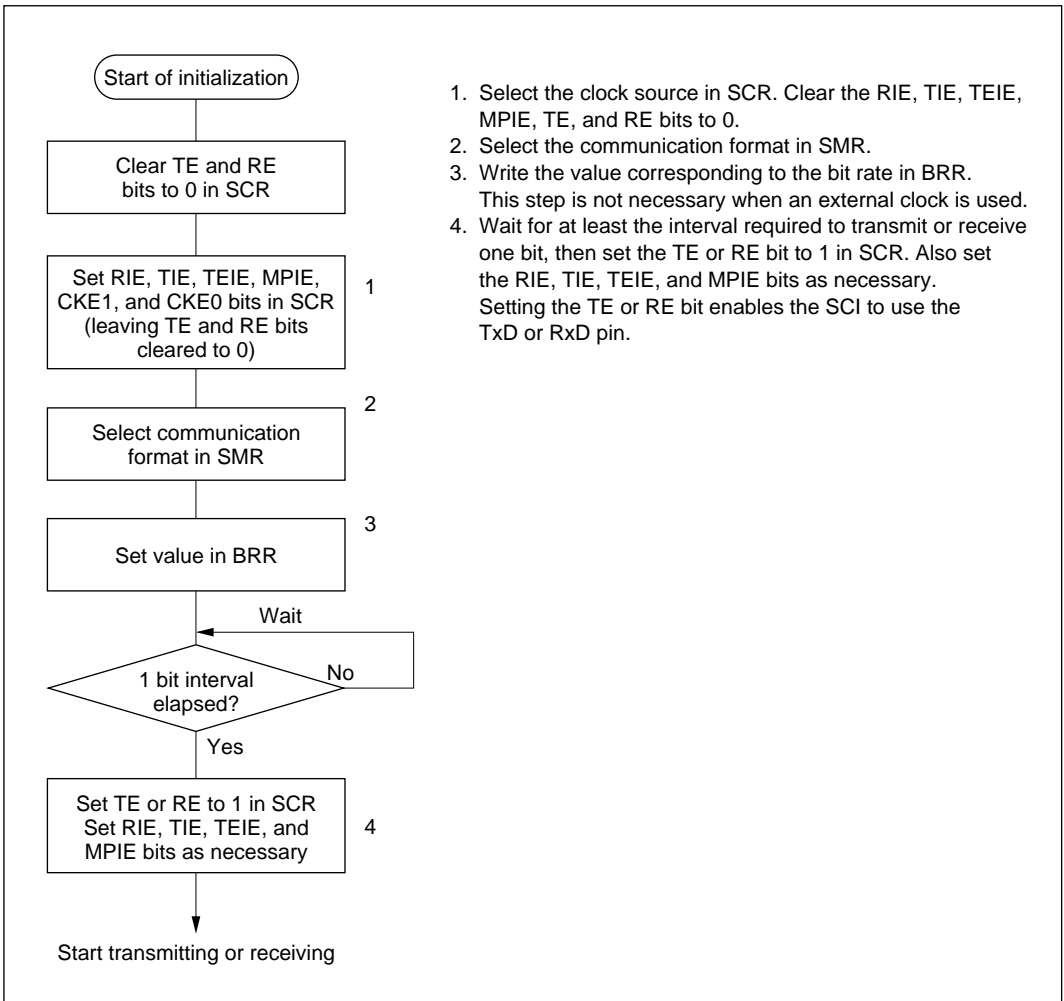

Figure 10-15 Sample Flowchart for SCI Initialization

Transmitting Serial Data (Synchronous Mode): Figure 10-16 shows a sample flowchart for transmitting serial data and indicates the procedure to follow.

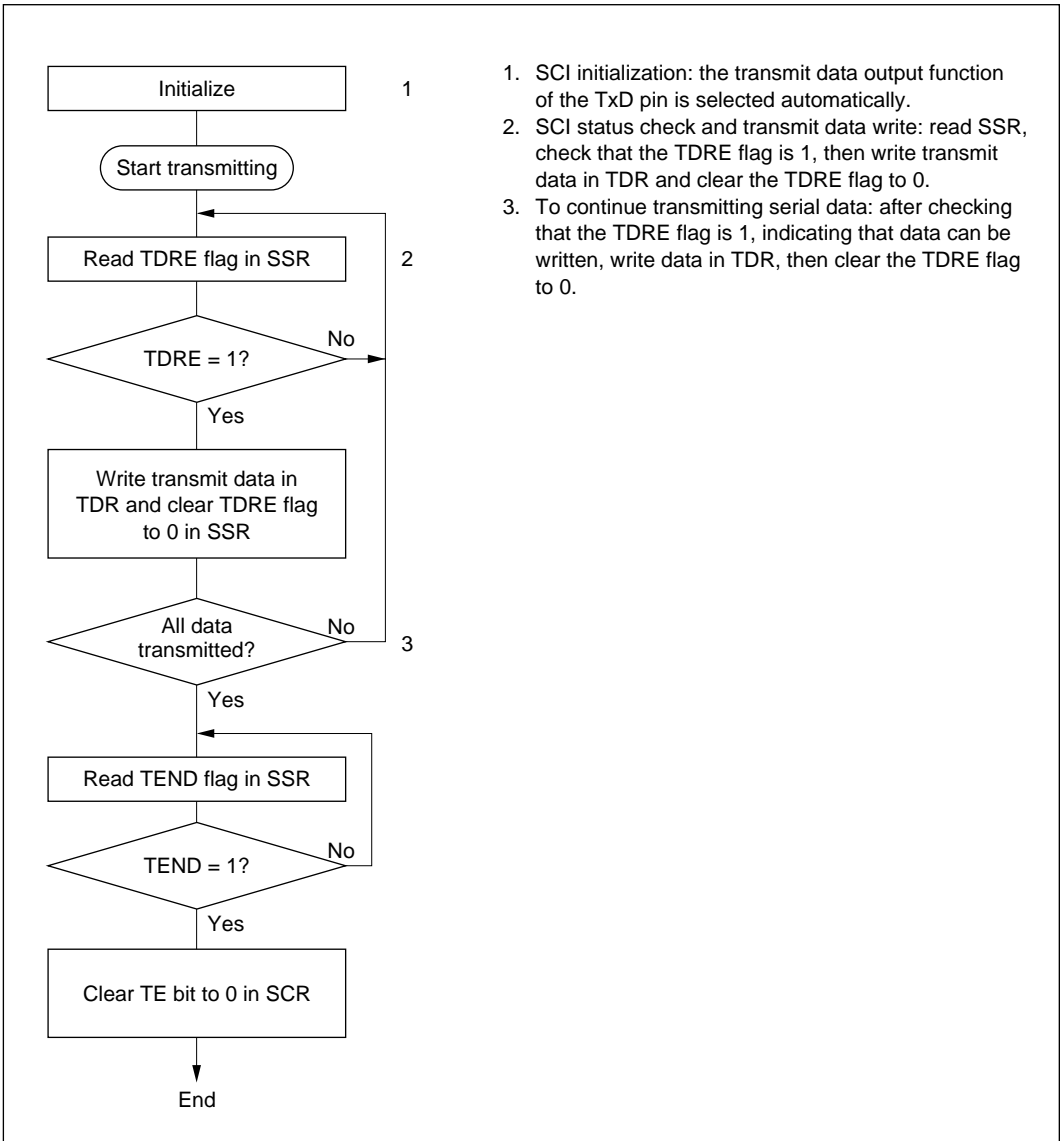

Figure 10-16 Sample Flowchart for Serial Transmitting

In transmitting serial data, the SCI operates as follows.

- The SCI monitors the TDRE flag in SSR. When the TDRE flag is cleared to 0 the SCI recognizes that TDR contains new data, and loads this data from TDR into TSR.
- After loading the data from TDR into TSR, the SCI sets the TDRE flag to 1 and starts transmitting. If the TIE bit is set to 1 in SCR, the SCI requests a transmit-data-empty interrupt (TXI) at this time.

If clock output is selected, the SCI outputs eight serial clock pulses. If an external clock source is selected, the SCI outputs data in synchronization with the input clock. Data is output from the TxD pin in order from LSB (bit 0) to MSB (bit 7).

- The SCI checks the TDRE flag when it outputs the MSB (bit 7). If the TDRE flag is 0, the SCI loads data from TDR into TSR and begins serial transmission of the next frame. If the TDRE flag is 1, the SCI sets the TEND flag to 1 in SSR, and after transmitting the MSB, holds the TxD pin in the MSB state. If the TEIE bit in SCR is set to 1, a transmit-end interrupt (TEI) is requested at this time.
- After the end of serial transmission, the SCK pin is held in a constant state.

Figure 10-17 shows an example of SCI transmit operation.

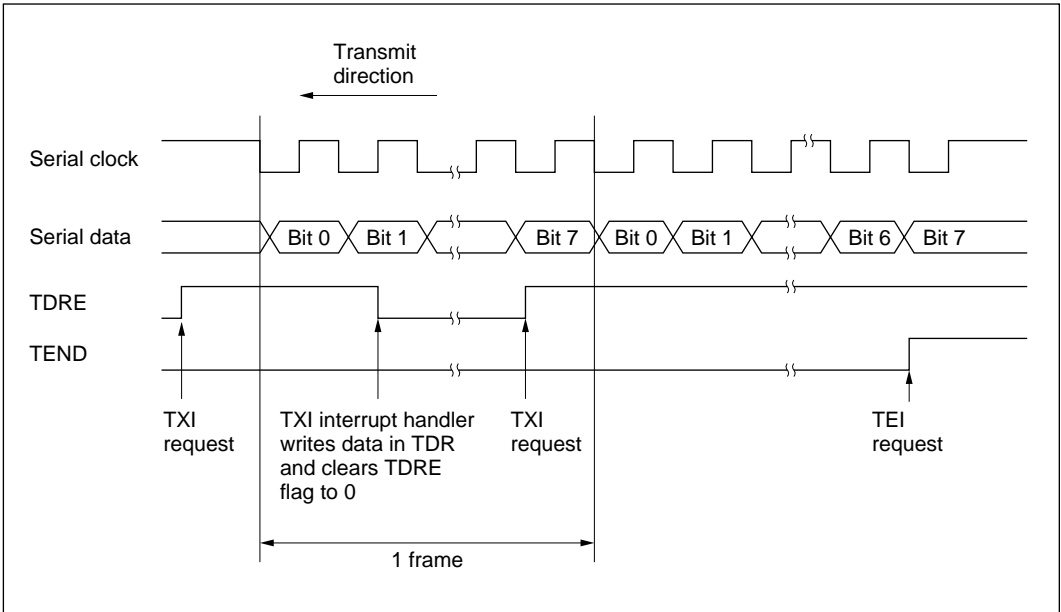
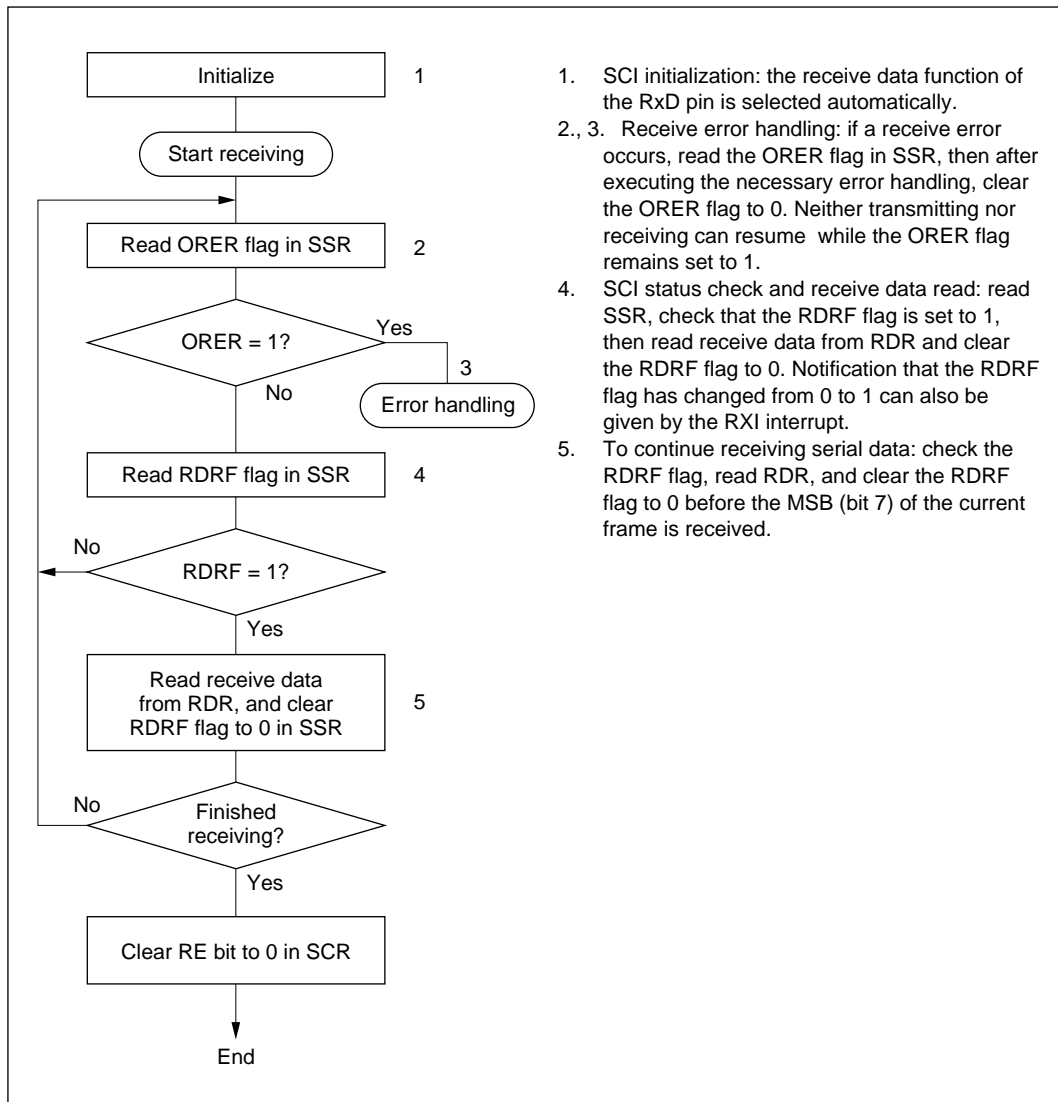

Figure 10-17 Example of SCI Transmit Operation

Receiving Serial Data: Figure 10-18 shows a sample flowchart for receiving serial data and indicates the procedure to follow. When switching from asynchronous mode to synchronous mode, make sure that the ORER, PER, and FER flags are cleared to 0. If the FER or PER flag is set to 1 the RDRF flag will not be set and both transmitting and receiving will be disabled.



1. SCI initialization: the receive data function of the RxD pin is selected automatically.
- 2., 3. Receive error handling: if a receive error occurs, read the ORER flag in SSR, then after executing the necessary error handling, clear the ORER flag to 0. Neither transmitting nor receiving can resume while the ORER flag remains set to 1.
4. SCI status check and receive data read: read SSR, check that the RDRF flag is set to 1, then read receive data from RDR and clear the RDRF flag to 0. Notification that the RDRF flag has changed from 0 to 1 can also be given by the RXI interrupt.
5. To continue receiving serial data: check the RDRF flag, read RDR, and clear the RDRF flag to 0 before the MSB (bit 7) of the current frame is received.

Figure 10-18 Sample Flowchart for Serial Receiving (1)

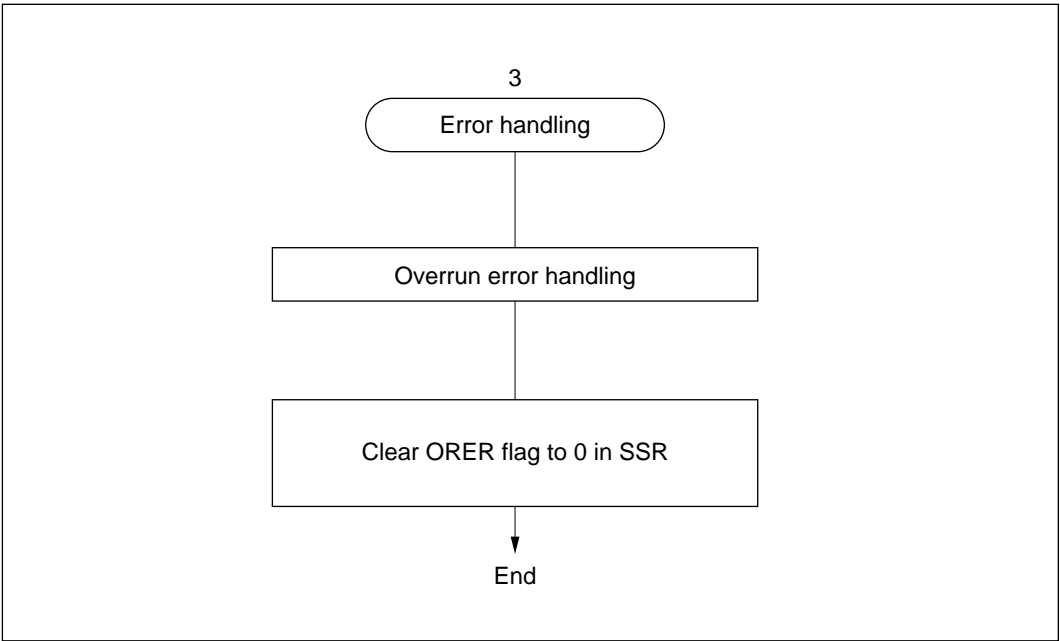

Figure 10-18 Sample Flowchart for Serial Receiving (2)

In receiving, the SCI operates as follows.

- The SCI synchronizes with serial clock input or output and initializes internally.
- Receive data is stored in RSR in order from LSB to MSB.

After receiving the data, the SCI checks that the RDRF flag is 0 so that receive data can be transferred from RSR to RDR. If this check passes, the RDRF flag is set to 1 and the received data is stored in RDR. If the check does not pass (receive error), the SCI operates as indicated in table 10-11.

- After setting the RDRF flag to 1, if the RIE bit is set to 1 in SCR, the SCI requests a receive-data-full interrupt (RXI). If the ORER flag is set to 1 and the RIE bit in SCR is also set to 1, the SCI requests a receive-error interrupt (ERI).

Figure 10-19 shows an example of SCI receive operation.

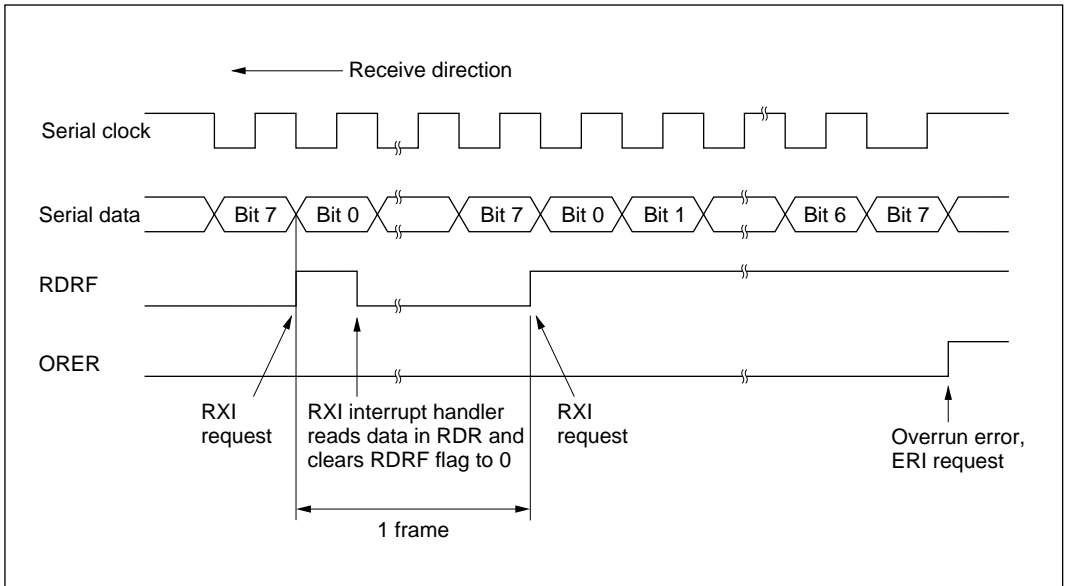
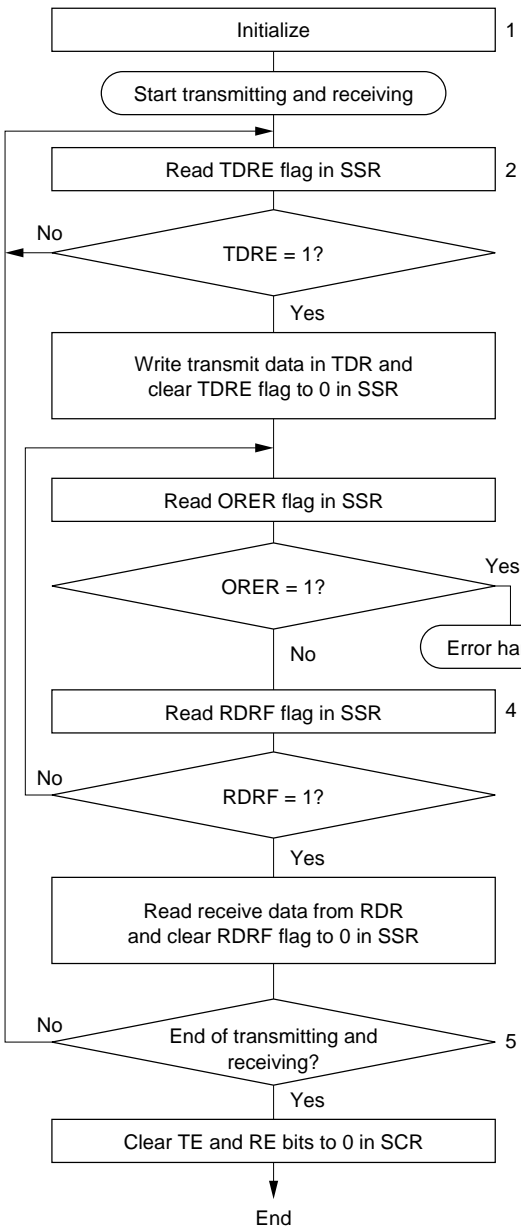

Figure 10-19 Example of SCI Receive Operation

Transmitting and Receiving Serial Data Simultaneously (Synchronous Mode): Figure 10-20 shows a sample flowchart for transmitting and receiving serial data simultaneously and indicates the procedure to follow.



1. SCI initialization: the transmit data output function of the TxD pin and receive data input function of the RxD pin are selected, enabling simultaneous transmitting and receiving.
2. SCI status check and transmit data write: read SSR, check that the TDRE flag is 1, then write transmit data in TDR and clear the TDRE flag to 0. Notification that the TDRE flag has changed from 0 to 1 can also be given by the TXI interrupt.
3. Receive error handling: if a receive error occurs, read the ORER flag in SSR, then after executing the necessary error handling, clear the ORER flag to 0. Neither transmitting nor receiving can resume while the ORER flag remains set to 1.
4. SCI status check and receive data read: read SSR, check that the RDRF flag is 1, then read receive data from RDR and clear the RDRF flag to 0. Notification that the RDRF flag has changed from 0 to 1 can also be given by the RXI interrupt.
5. To continue transmitting and receiving serial data: check the RDRF flag, read RDR, and clear the RDRF flag to 0 before the MSB (bit 7) of the current frame is received. Also check that the TDRE flag is (bit 7) of the current frame is received. Also check that the TDRE flag is set to 1, indicating that data can be written, write data in TDR, then clear the TDRE flag to 0 before the MSB (bit 7) of the current frame is transmitted. When the DMAC is activated by a transmit-data-empty interrupt request (TXI) to write data in TDR, the TDRE flag is checked and cleared automatically.

Note: * When switching from transmitting or receiving to simultaneous transmitting and receiving, clear the TE and RE bits both to 0, then set the TE and RE bits both to 1.

Figure 10-20 Sample Flowchart for Serial Transmitting

10.4 SCI Interrupts

The SCI has four interrupt request sources: TEI (transmit-end interrupt), ERI (receive-error interrupt), RXI (receive-data-full interrupt), and TXI (transmit-data-empty interrupt). Table 10-12 lists the interrupt sources and indicates their priority. These interrupts can be enabled and disabled by the TIE, TEIE, and RIE bits in SCR. Each interrupt request is sent separately to the interrupt controller.

The TXI interrupt is requested when the TDRE flag is set to 1 in SSR. The TEI interrupt is requested when the TEND flag is set to 1 in SSR.

The RXI interrupt is requested when the RDRF flag is set to 1 in SSR. The ERI interrupt is requested when the ORER, PER, or FER flag is set to 1 in SSR.

Table 10-12 SCI Interrupt Sources

Interrupt	Description	Priority
ERI	Receive error (ORER, FER, or PER)	High
RXI	Receive data register full (RDRF)	↑
TXI	Transmit data register empty (TDRE)	
TEI	Transmit end (TEND)	Low

10.5 Usage Notes

Note the following points when using the SCI.

TDR Write and TDRE Flag: The TDRE flag in SSR is a status flag indicating the loading of transmit data from TDR into TSR. The SCI sets the TDRE flag to 1 when it transfers data from TDR to TSR.

Data can be written into TDR regardless of the state of the TDRE flag. If new data is written in TDR when the TDRE flag is 0, the old data stored in TDR will be lost because this data has not yet been transferred to TSR. Before writing transmit data in TDR, be sure to check that the TDRE flag is set to 1.

Simultaneous Multiple Receive Errors: Table 10-13 indicates the state of SSR status flags when multiple receive errors occur simultaneously. When an overrun error occurs the RSR contents are not transferred to RDR, so receive data is lost.

Table 10-13 SSR Status Flags and Transfer of Receive Data

SSR Status Flags				Receive Data Transfer	Receive Errors
RDRF	ORER	FER	PER	RSR →RDR	
1	1	0	0	×	Overrun error
0	0	1	0	○	Framing error
0	0	0	1	○	Parity error
1	1	1	0	×	Overrun error + framing error
1	1	0	1	×	Overrun error + parity error
0	0	1	1	○	Framing error + parity error
1	1	1	1	×	Overrun error + framing error + parity error

Notes: ○: Receive data is transferred from RSR to RDR.

×: Receive data is not transferred from RSR to RDR.

Break Detection and Processing: Break signals can be detected by reading the RxD pin directly when a framing error (FER) is detected. In the break state the input from the RxD pin consists of all 0s, so the FER flag is set and the parity error flag (PER) may also be set. In the break state the SCI receiver continues to operate, so if the FER flag is cleared to 0 it will be set to 1 again.

Sending a Break Signal: When the TE bit is cleared to 0 the TxD pin becomes an I/O port, the level and direction (input or output) of which are determined by DR and DDR bits. This feature can be used to send a break signal.

After the serial transmitter is initialized, the DR value substitutes for the mark state until the TE bit is set to 1 (the TxD pin function is not selected until the TE bit is set to 1). The DDR and DR bits should therefore both be set to 1 beforehand.

To send a break signal during serial transmission, clear the DR bit to 0, then clear the TE bit to 0. When the TE bit is cleared to 0 the transmitter is initialized, regardless of its current state, so the TxD pin becomes an output port outputting the value 0.

Receive Error Flags and Transmitter Operation (Synchronous Mode Only): When a receive error flag (ORER, PER, or FER) is set to 1 the SCI will not start transmitting, even if the TDRE flag is cleared to 0. Be sure to clear the receive error flags to 0 when starting to transmit. Note that clearing the RE bit to 0 does not clear the receive error flags to 0.

Receive Data Sampling Timing in Asynchronous Mode and Receive Margin: In asynchronous mode the SCI operates on a base clock with 16 times the bit rate frequency. In receiving, the SCI synchronizes internally with the fall of the start bit, which it samples on the base clock. Receive data is latched at the rising edge of the eighth base clock pulse. See figure 10-21.

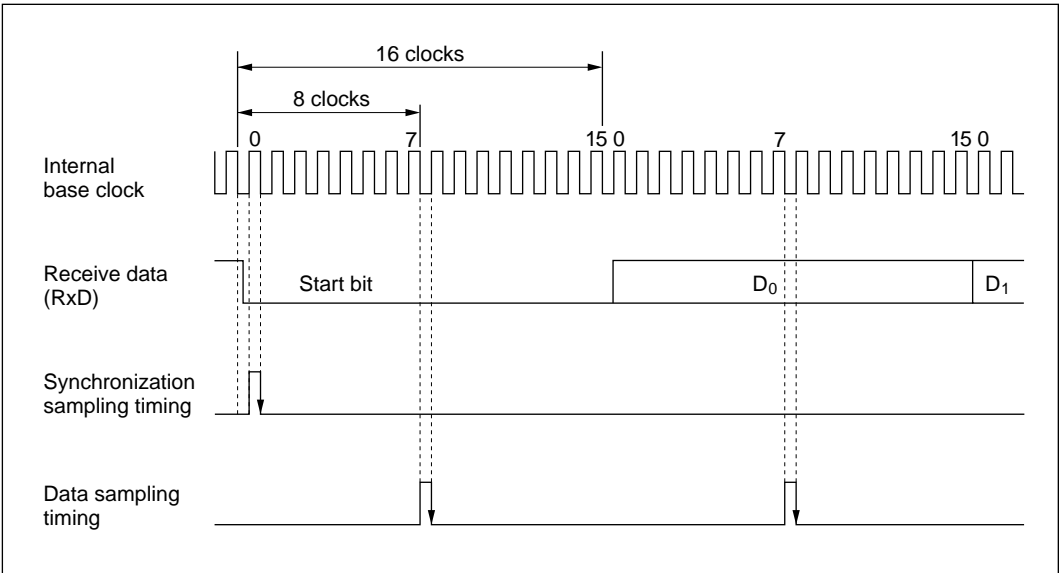

Figure 10-21 Receive Data Sampling Timing in Asynchronous Mode

The receive margin in asynchronous mode can therefore be expressed as in equation (1).

$$M = \left| \left(0.5 - \frac{1}{2N} \right) - (L - 0.5) F - \frac{|D - 0.5|}{N} (1 + F) \right| \times 100\% \dots \dots \dots (1)$$

- M: Receive margin (%)
- N: Ratio of clock frequency to bit rate (N = 16)
- D: Clock duty cycle (D = 0 to 1.0)
- L: Frame length (L = 9 to 12)
- F: Absolute deviation of clock frequency

From equation (1), if F = 0 and D = 0.5 the receive margin is 46.875%, as given by equation (2).

$$\begin{aligned}
 D &= 0.5, F = 0 \\
 M &= [0.5 - 1/(2 \times 16)] \times 100\% \\
 &= 46.875\% \dots \dots \dots (2)
 \end{aligned}$$

This is a theoretical value. A reasonable margin to allow in system designs is 20% to 30%.

Restrictions in Synchronous Mode: When an external clock source is used in synchronous mode, after TDR is reset, wait at least 5 clock counts (5ϕ) before inputting the transmit clock. If the clock is input four states after the reset of TDR or earlier, an operation error may occur (figure 10-22).

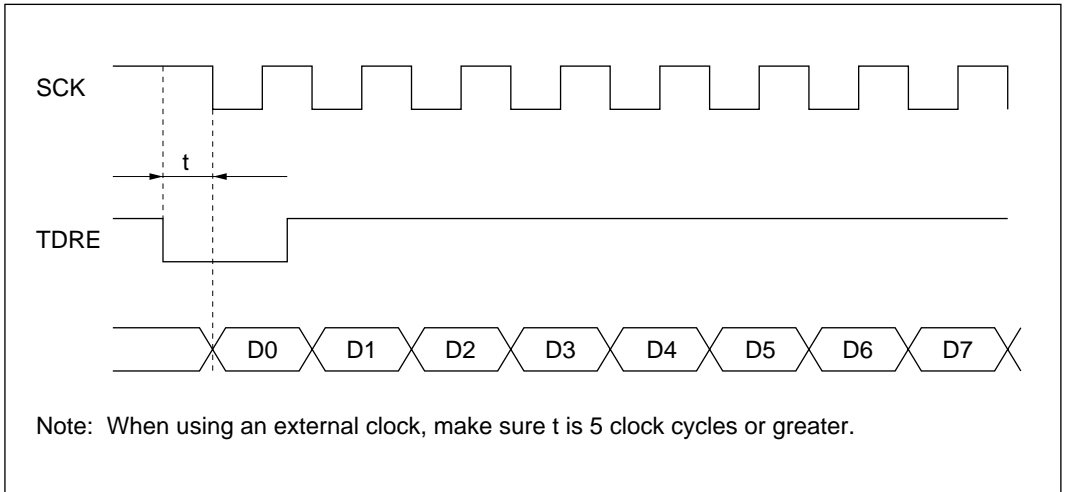

Figure 10-22 Transmission in Synchronous Mode (Example)

Section 11 A/D Converter

11.1 Overview

The H8/3004 and H8/3005 include a 10-bit successive-approximations A/D converter with a selection of up to eight analog input channels.

11.1.1 Features

A/D converter features are listed below.

- 10-bit resolution
- Eight input channels
- Selectable analog conversion voltage range

The analog voltage conversion range can be programmed by input of an analog reference voltage at the V_{REF} pin.

- High-speed conversion

Conversion time: maximum 8.4 μ s per channel (with 16 MHz system clock)

- Two conversion modes

Single mode: A/D conversion of one channel

Scan mode: continuous conversion on one to four channels

- Four 16-bit data registers

A/D conversion results are transferred for storage into data registers corresponding to the channels.

- Sample-and-hold function
- A/D conversion can be externally triggered
- A/D interrupt requested at end of conversion

At the end of A/D conversion, an A/D end interrupt (ADI) can be requested.

11.1.2 Block Diagram

Figure 11-1 shows a block diagram of the A/D converter.

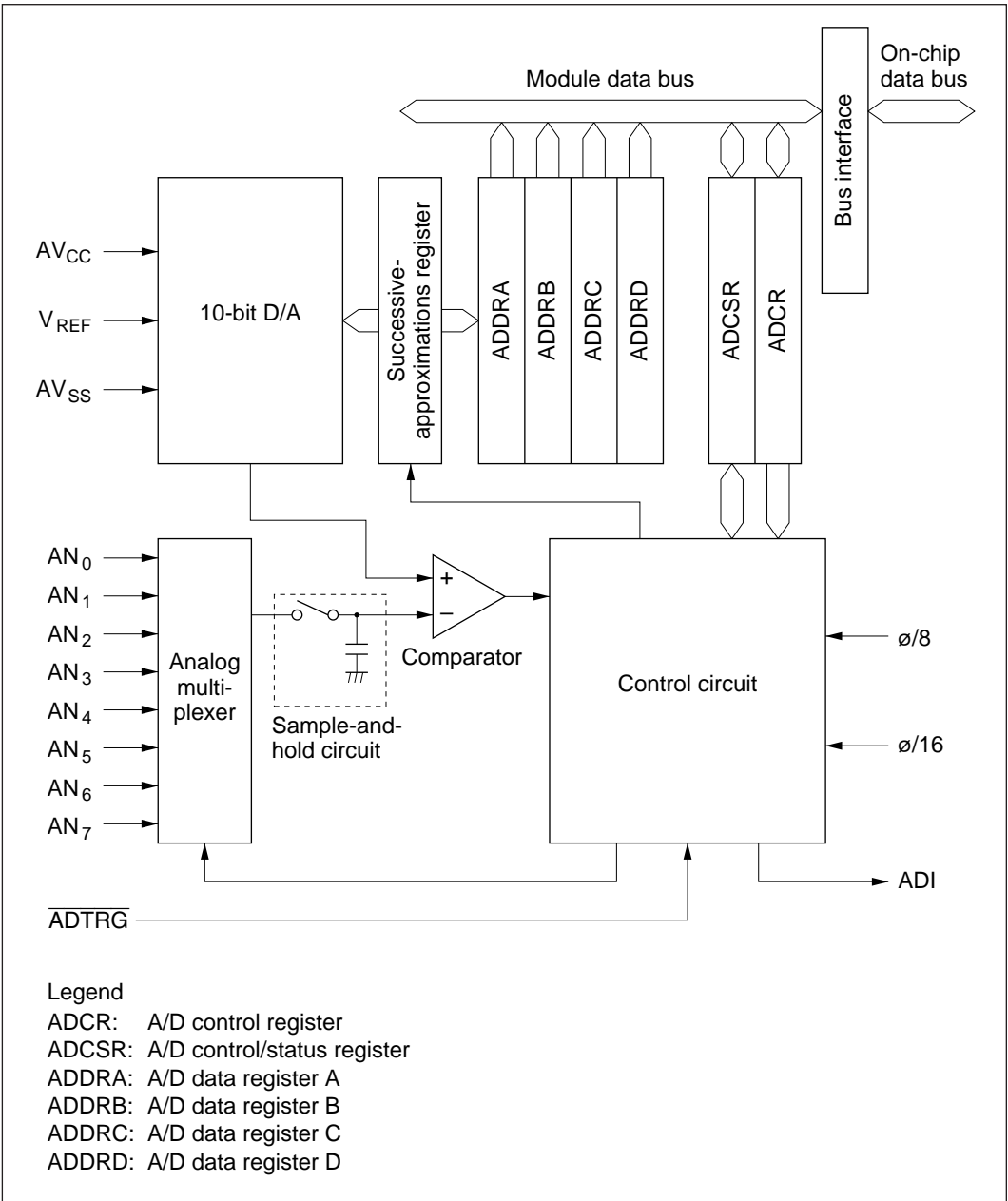

Figure 11-1 A/D Converter Block Diagram

11.1.3 Input Pins

Table 11-1 summarizes the A/D converter's input pins. The eight analog input pins are divided into two groups: group 0 (AN_0 to AN_3), and group 1 (AN_4 to AN_7). AV_{CC} and AV_{SS} are the power supply for the analog circuits in the A/D converter. V_{REF} is the A/D conversion reference voltage.

Table 11-1 A/D Converter Pins

Pin Name	Abbreviation	I/O	Function
Analog power supply pin	AV_{CC}	Input	Analog power supply
Analog ground pin	AV_{SS}	Input	Analog ground and reference voltage
Reference voltage pin	V_{REF}	Input	Analog reference voltage
Analog input pin 0	AN_0	Input	Group 0 analog inputs
Analog input pin 1	AN_1	Input	
Analog input pin 2	AN_2	Input	
Analog input pin 3	AN_3	Input	
Analog input pin 4	AN_4	Input	Group 1 analog inputs
Analog input pin 5	AN_5	Input	
Analog input pin 6	AN_6	Input	
Analog input pin 7	AN_7	Input	
A/D external trigger input pin	\overline{ADTRG}	Input	External trigger input for starting A/D conversion

11.1.4 Register Configuration

Table 11-2 summarizes the A/D converter's registers.

Table 11-2 A/D Converter Registers

Address*1	Name	Abbreviation	R/W	Initial Value
H'FFE0	A/D data register A (high)	ADDRAH	R	H'00
H'FFE1	A/D data register A (low)	ADDRAL	R	H'00
H'FFE2	A/D data register B (high)	ADDRBH	R	H'00
H'FFE3	A/D data register B (low)	ADDRBL	R	H'00
H'FFE4	A/D data register C (high)	ADDRCH	R	H'00
H'FFE5	A/D data register C (low)	ADDRCL	R	H'00
H'FFE6	A/D data register D (high)	ADDRDH	R	H'00
H'FFE7	A/D data register D (low)	ADDRDL	R	H'00
H'FFE8	A/D control/status register	ADCSR	R/(W)*2	H'00
H'FFE9	A/D control register	ADCR	R/W	H'7F

- Notes: 1. Lower 16 bits of the address
2. Only 0 can be written in bit 7, to clear the flag.

11.2 Register Descriptions

11.2.1 A/D Data Registers A to D (ADDRA to ADDR D)

Bit	15	14	13	12	11	10	9	8	7	6	5	4	3	2	1	0
ADDR _n	AD9	AD8	AD7	AD6	AD5	AD4	AD3	AD2	AD1	AD0	—	—	—	—	—	—
Initial value	0	0	0	0	0	0	0	0	0	0	0	0	0	0	0	0
Read/Write (n = A to D)	R	R	R	R	R	R	R	R	R	R	R	R	R	R	R	R

A/D conversion data
10-bit data giving an
A/D conversion result
Reserved bits

The four A/D data registers (ADDRA to ADDR D) are 16-bit read-only registers that store the results of A/D conversion.

An A/D conversion produces 10-bit data, which is transferred for storage into the A/D data register corresponding to the selected channel. The upper 8 bits of the result are stored in the upper byte of the A/D data register. The lower 2 bits are stored in the lower byte. Bits 5 to 0 of an A/D data register are reserved bits that always read 0. Table 11-3 indicates the pairings of analog input channels and A/D data registers.

The CPU can always read and write the A/D data registers. The upper byte can be read directly, but the lower byte is read through a temporary register (TEMP). For details see section 11.3, CPU Interface.

The A/D data registers are initialized to H'0000 by a reset and in standby mode.

Table 11-3 Analog Input Channels and A/D Data Registers

Analog Input Channel		A/D Data Register
Group 0	Group 1	
AN ₀	AN ₄	ADDRA
AN ₁	AN ₅	ADDRB
AN ₂	AN ₆	ADDRC
AN ₃	AN ₇	ADDRD

11.2.2 A/D Control/Status Register (ADCSR)

Bit	7	6	5	4	3	2	1	0
	ADF	ADIE	ADST	SCAN	CKS	CH2	CH1	CH0
Initial value	0	0	0	0	0	0	0	0
Read/Write	R/(W)*	R/W	R/W	R/W	R/W	R/W	R/W	R/W

A/D end flag
 Indicates end of A/D conversion

A/D interrupt enable
 Enables and disables A/D end interrupts

A/D start
 Starts or stops A/D conversion

Scan mode
 Selects single mode or scan mode

Clock select
 Selects the A/D conversion time

Channel select 2 to 0
 These bits select analog input channels

Note: * Only 0 can be written, to clear the flag.

ADCSR is an 8-bit readable/writable register that selects the mode and controls the A/D converter. ADCSR is initialized to H'00 by a reset and in standby mode.

Bit 7—A/D End Flag (ADF): Indicates the end of A/D conversion.

Bit 7

ADF	Description	
0	[Clearing condition] Cleared by reading ADF while ADF = 1, then writing 0 in ADF	(Initial value)
1	[Setting conditions] Single mode: A/D conversion ends Scan mode: A/D conversion ends in all selected channels	

Bit 6—A/D Interrupt Enable (ADIE): Enables or disables the interrupt (ADI) requested at the end of A/D conversion.

Bit 6

ADIE	Description	
0	A/D end interrupt request (ADI) is disabled	(Initial value)
1	A/D end interrupt request (ADI) is enabled	

Bit 5—A/D Start (ADST): Starts or stops A/D conversion. The ADST bit remains set to 1 during A/D conversion. It can also be set to 1 by external trigger input at the $\overline{\text{ADTRG}}$ pin.

Bit 5

ADST	Description	
0	A/D conversion is stopped	(Initial value)
1	Single mode: A/D conversion starts; ADST is automatically cleared to 0 when conversion ends. Scan mode: A/D conversion starts and continues, cycling among the selected channels, until ADST is cleared to 0 by software, by a reset, or by a transition to standby mode.	

Bit 4—Scan Mode (SCAN): Selects single mode or scan mode. For further information on operation in these modes, see section 11.4, Operation. Clear the ADST bit to 0 before switching the conversion mode.

Bit 4		
SCAN	Description	
0	Single mode	(Initial value)
1	Scan mode	

Bit 3—Clock Select (CKS): Selects the A/D conversion time. Clear the ADST bit to 0 before switching the conversion time.

Bit 3		
CKS	Description	
0	Conversion time = 266 states (maximum)	(Initial value)
1	Conversion time = 134 states (maximum)	

Bits 2 to 0—Channel Select 2 to 0 (CH2 to CH0): These bits and the SCAN bit select the analog input channels. Clear the ADST bit to 0 before changing the channel selection.

Group Selection	Channel Selection		Description	
	CH1	CH0	Single Mode	Scan Mode
0	0	0	AN ₀ (Initial value)	AN ₀
		1	AN ₁	AN ₀ , AN ₁
	1	0	AN ₂	AN ₀ to AN ₂
		1	AN ₃	AN ₀ to AN ₃
1	0	0	AN ₄	AN ₄
		1	AN ₅	AN ₄ , AN ₅
	1	0	AN ₆	AN ₄ to AN ₆
		1	AN ₇	AN ₄ to AN ₇

11.2.3 A/D Control Register (ADCR)

Bit	7	6	5	4	3	2	1	0
	TRGE	—	—	—	—	—	—	—
Initial value	0	1	1	1	1	1	1	1
Read/Write	R/W	—	—	—	—	—	—	—

Reserved bits

Trigger enable
Enables or disables external triggering of A/D conversion

ADCR is an 8-bit readable/writable register that enables or disables external triggering of A/D conversion. ADCR is initialized to H'7F by a reset and in standby mode.

Bit 7—Trigger Enable (TRGE): Enables or disables external triggering of A/D conversion.

Bit 7

TRGE	Description
0	A/D conversion cannot be externally triggered (Initial value)
1	A/D conversion starts at the falling edge of the external trigger signal ($\overline{\text{ADTRG}}$)

Bits 6 to 0—Reserved: Read-only bits, always read as 1.

11.3 CPU Interface

ADDRA to ADDRd are 16-bit registers, but they are connected to the CPU by an 8-bit data bus. Therefore, although the upper byte can be accessed directly by the CPU, the lower byte is read through an 8-bit temporary register (TEMP).

An A/D data register is read as follows. When the upper byte is read, the upper-byte value is transferred directly to the CPU and the lower-byte value is transferred into TEMP. Next, when the lower byte is read, the TEMP contents are transferred to the CPU.

When reading an A/D data register, always read the upper byte before the lower byte. It is possible to read only the upper byte, but if only the lower byte is read, incorrect data may be obtained.

Figure 11-2 shows the data flow for access to an A/D data register.

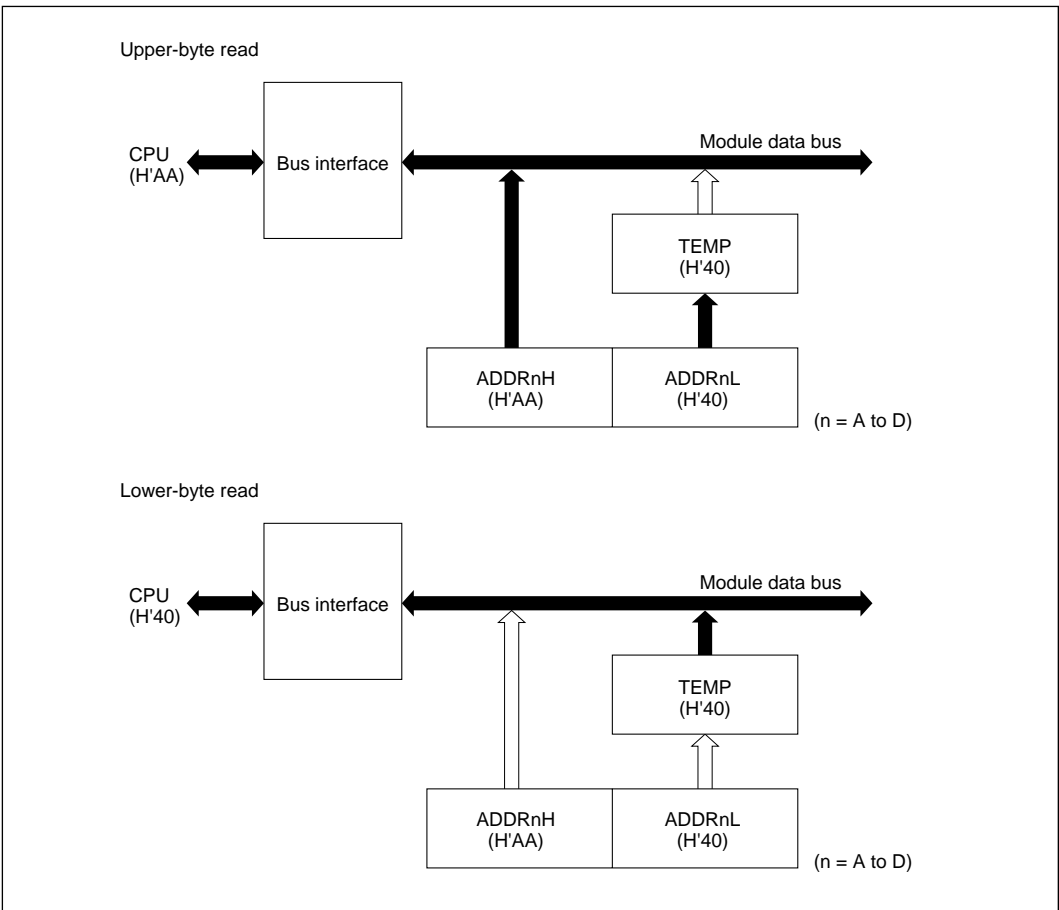

Figure 11-2 A/D Data Register Access Operation (Reading H'AA40)

11.4 Operation

The A/D converter operates by successive approximations with 10-bit resolution. It has two operating modes: single mode and scan mode.

11.4.1 Single Mode (SCAN = 0)

Single mode should be selected when only one A/D conversion on one channel is required. A/D conversion starts when the ADST bit is set to 1 by software, or by external trigger input. The ADST bit remains set to 1 during A/D conversion and is automatically cleared to 0 when conversion ends.

When conversion ends the ADF bit is set to 1. If the ADIE bit is also set to 1, an ADI interrupt is requested at this time. To clear the ADF flag to 0, first read ADCSR, then write 0 in ADF.

When the mode or analog input channel must be switched during analog conversion, to prevent incorrect operation, first clear the ADST bit to 0 in ADCSR to halt A/D conversion. After making the necessary changes, set the ADST bit to 1 to start A/D conversion again. The ADST bit can be set at the same time as the mode or channel is changed.

Typical operations when channel 1 (AN_1) is selected in single mode are described next. Figure 11-3 shows a timing diagram for this example.

1. Single mode is selected (SCAN = 0), input channel AN_1 is selected (CH2 = CH1 = 0, CH0 = 1), the A/D interrupt is enabled (ADIE = 1), and A/D conversion is started (ADST = 1).
2. When A/D conversion is completed, the result is transferred into ADDR0. At the same time the ADF flag is set to 1, the ADST bit is cleared to 0, and the A/D converter becomes idle.
3. Since ADF = 1 and ADIE = 1, an ADI interrupt is requested.
4. The A/D interrupt handling routine starts.
5. The routine reads ADCSR, then writes 0 in the ADF flag.
6. The routine reads and processes the conversion result (ADDR0).
7. Execution of the A/D interrupt handling routine ends. After that, if the ADST bit is set to 1, A/D conversion starts again and steps 2 to 7 are repeated.

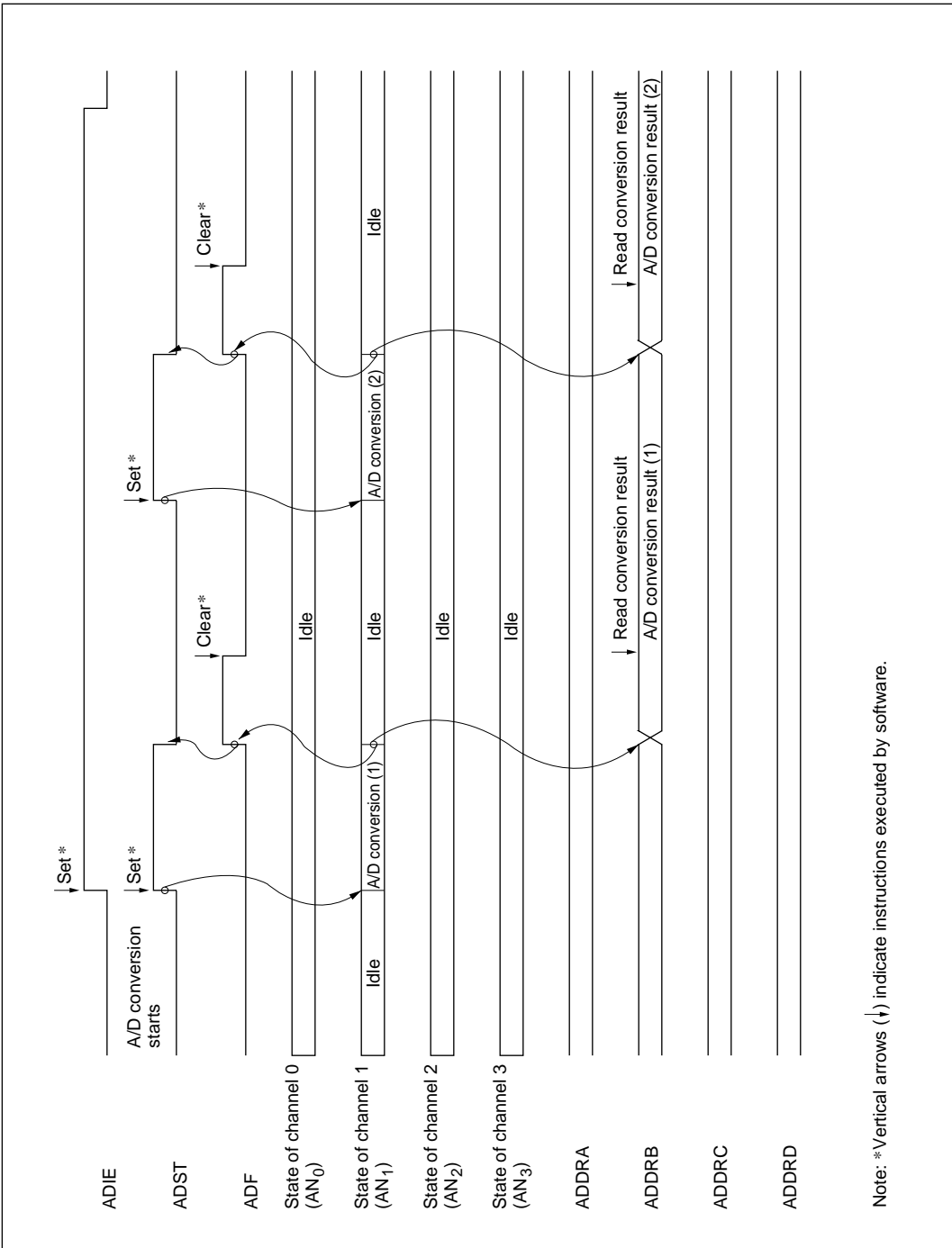

Note: *Vertical arrows (↓) indicate instructions executed by software.

Figure 11-3 Example of A/D Converter Operation (Single Mode, Channel 1 Selected)

11.4.2 Scan Mode (SCAN = 1)

Scan mode is useful for monitoring analog inputs in a group of one or more channels. When the ADST bit is set to 1 by software or external trigger input, A/D conversion starts on the first channel in the group (AN_0 when $CH2 = 0$, AN_4 when $CH2 = 1$). When two or more channels are selected, after conversion of the first channel ends, conversion of the second channel (AN_1 or AN_5) starts immediately. A/D conversion continues cyclically on the selected channels until the ADST bit is cleared to 0. The conversion results are transferred for storage into the A/D data registers corresponding to the channels.

When the mode or analog input channel selection must be changed during analog conversion, to prevent incorrect operation, first clear the ADST bit to 0 in ADCSR to halt A/D conversion. After making the necessary changes, set the ADST bit to 1. A/D conversion will start again from the first channel in the group. The ADST bit can be set at the same time as the mode or channel selection is changed.

Typical operations when three channels in group 0 (AN_0 to AN_2) are selected in scan mode are described next. Figure 11-4 shows a timing diagram for this example.

1. Scan mode is selected (SCAN = 1), scan group 0 is selected (CH2 = 0), analog input channels AN_0 to AN_2 are selected (CH1 = 1, CH0 = 0), and A/D conversion is started (ADST = 1).
2. When A/D conversion of the first channel (AN_0) is completed, the result is transferred into ADDRA. Next, conversion of the second channel (AN_1) starts automatically.
3. Conversion proceeds in the same way through the third channel (AN_2).
4. When conversion of all selected channels (AN_0 to AN_2) is completed, the ADF flag is set to 1 and conversion of the first channel (AN_0) starts again. If the ADIE bit is set to 1, an ADI interrupt is requested at this time.
5. Steps 2 to 4 are repeated as long as the ADST bit remains set to 1. When the ADST bit is cleared to 0, A/D conversion stops. After that, if the ADST bit is set to 1, A/D conversion starts again from the first channel (AN_0).

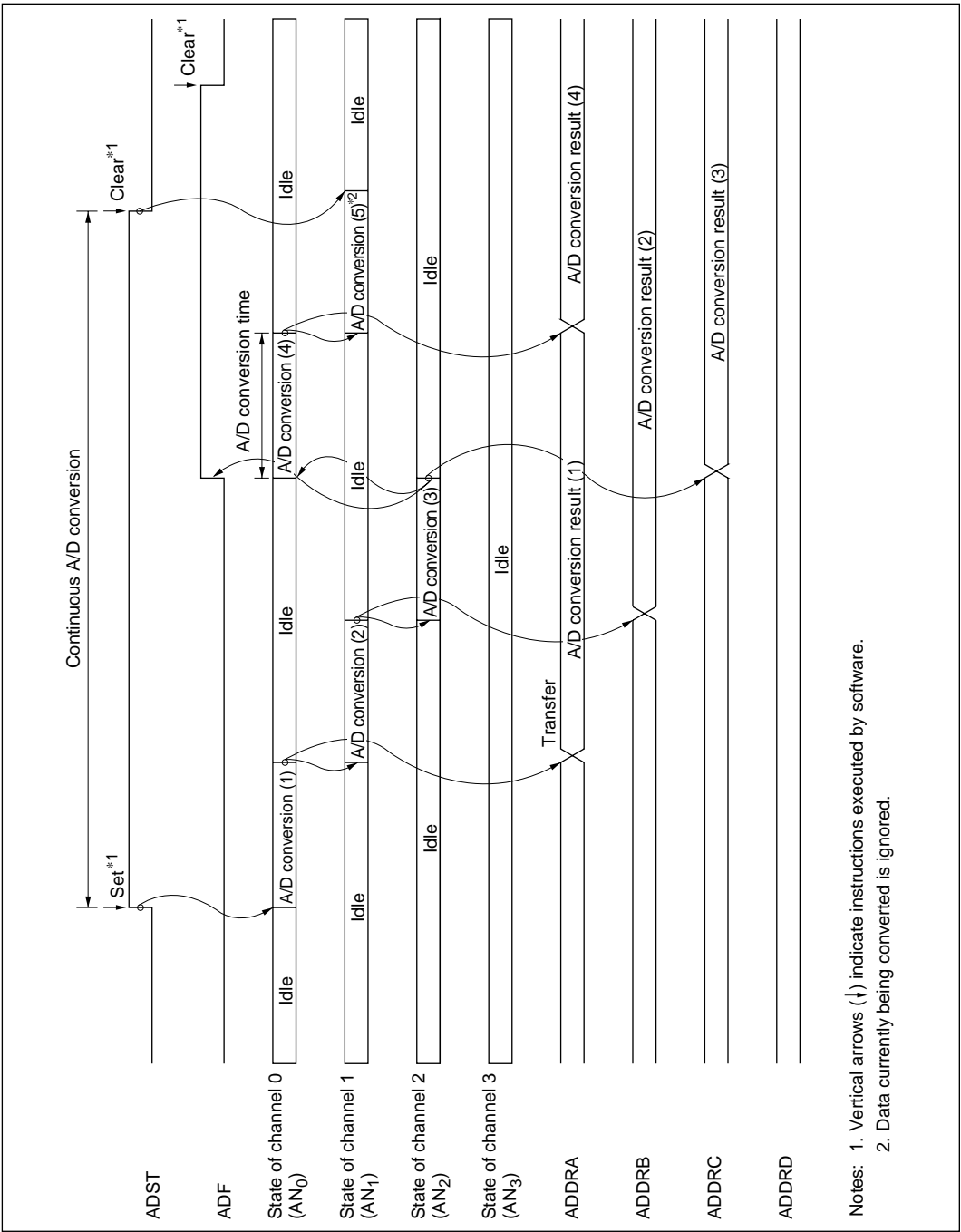

- Notes:
1. Vertical arrows (↑) indicate instructions executed by software.
 2. Data currently being converted is ignored.

Figure 11-4 Example of A/D Converter Operation (Scan Mode, Channels AN₀ to AN₂ Selected)

11.4.3 Input Sampling and A/D Conversion Time

The A/D converter has a built-in sample-and-hold circuit. The A/D converter samples the analog input at a time t_D after the ADST bit is set to 1, then starts conversion. Figure 11-5 shows the A/D conversion timing. Table 11-4 indicates the A/D conversion time.

As indicated in figure 11-5, the A/D conversion time includes t_D and the input sampling time. The length of t_D varies depending on the timing of the write access to ADCSR. The total conversion time therefore varies within the ranges indicated in table 11-4.

In scan mode, the values given in table 11-4 apply to the first conversion. In the second and subsequent conversions the conversion time is fixed at 256 states when $CKS = 0$ or 118 states when $CKS = 1$.

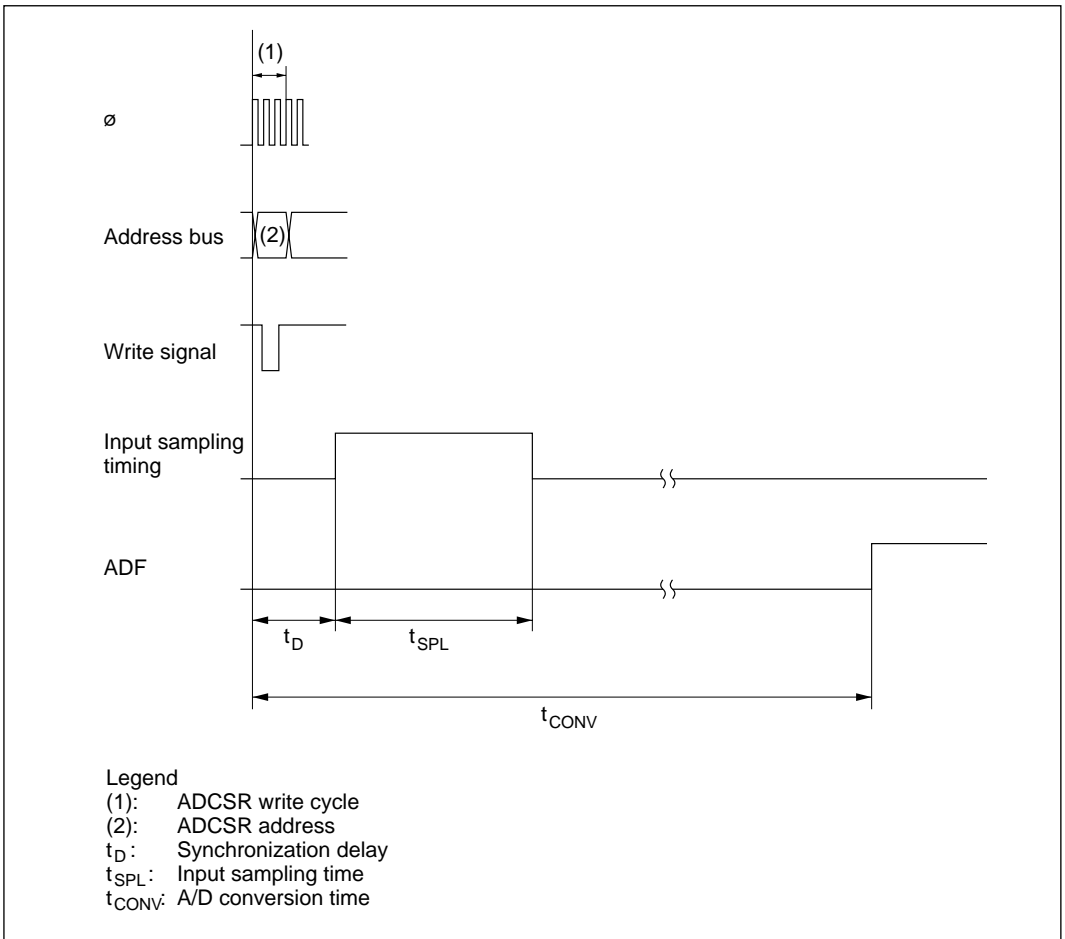

Figure 11-5 A/D Conversion Timing

Table 11-4 A/D Conversion Time (Single Mode)

	Symbol	CKS = 0			CKS = 1		
		Min	Typ	Max	Min	Typ	Max
Synchronization delay	t_D	10	—	17	6	—	9
Input sampling time	t_{SPL}	—	80	—	—	40	—
A/D conversion time	t_{CONV}	259	—	266	131	—	134

Note: Values in the table are numbers of states.

11.4.4 External Trigger Input Timing

A/D conversion can be externally triggered. When the TRGE bit is set to 1 in ADCR, external trigger input is enabled at the \overline{ADTRG} pin. A high-to-low transition at the \overline{ADTRG} pin sets the ADST bit to 1 in ADCSR, starting A/D conversion. Other operations, in both single and scan modes, are the same as if the ADST bit had been set to 1 by software. Figure 11-6 shows the timing.

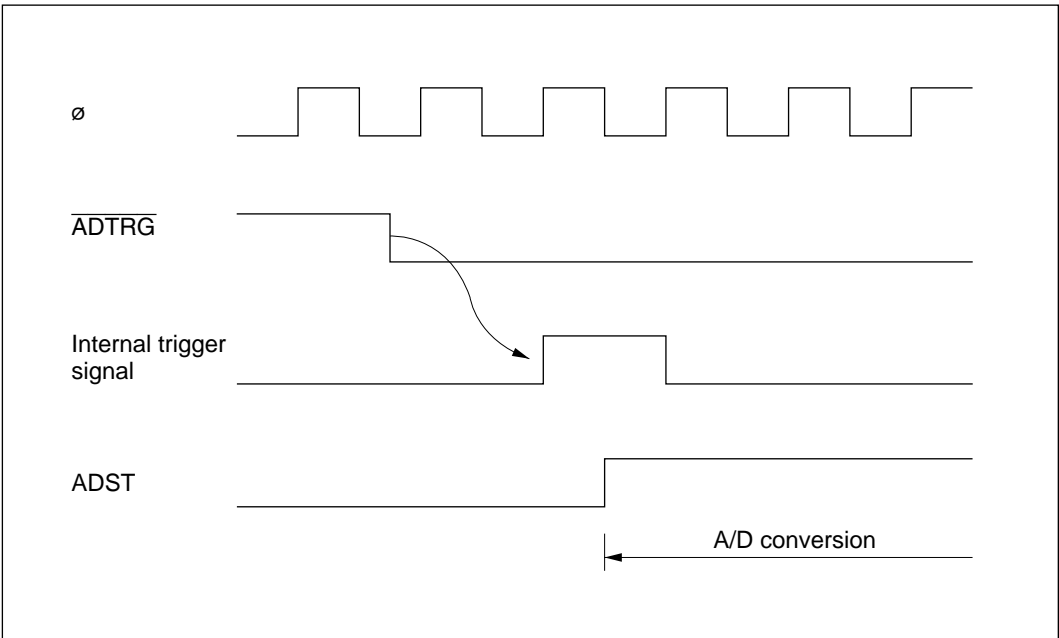

Figure 11-6 External Trigger Input Timing

11.5 Interrupts

The A/D converter generates an interrupt (ADI) at the end of A/D conversion. The ADI interrupt request can be enabled or disabled by the ADIE bit in ADCSR.

11.6 Usage Notes

When using the A/D converter, note the following points:

Analog Input Voltage Range: During A/D conversion, the voltages input to the analog input pins AN_n should be in the range $AV_{SS} \leq AN_n \leq V_{REF}$. (n = 0 to 7)

AV_{CC} and AV_{SS} Input Voltages: AV_{SS} should have the following values: $AV_{SS} = V_{SS}$.

If the A/D converter is not used, the values should be $AV_{CC} = V_{CC}$ and $AV_{SS} = V_{SS}$.

V_{REF} Input Range: The analog reference voltage input at the V_{REF} pin should be in the range $V_{REF} \leq AV_{CC}$. If the A/D converter is not used, the value should be $V_{REF} = V_{CC}$.

Section 12 RAM

12.1 Overview

The H8/3004 has 2 kbytes of on-chip static RAM, and the H8/3005 has 4 kbytes. The RAM is connected to the CPU by a 16-bit data bus. The CPU accesses both byte data and word data in two states, making the RAM suitable for rapid data transfer.

The H8/3004 on-chip RAM is assigned to addresses H'FF710 to H'FFF0F. The H8/3005 on-chip RAM is assigned to addresses H'FEF10 to H'FFF0F. The RAM enable bit (RAME) in the system control register (SYSCR) can enable or disable the on-chip RAM.

12.1.1 Block Diagram

Figures 12-1 and 12-2 show block diagrams of the H8/3004 and H8/3005 on-chip RAM.

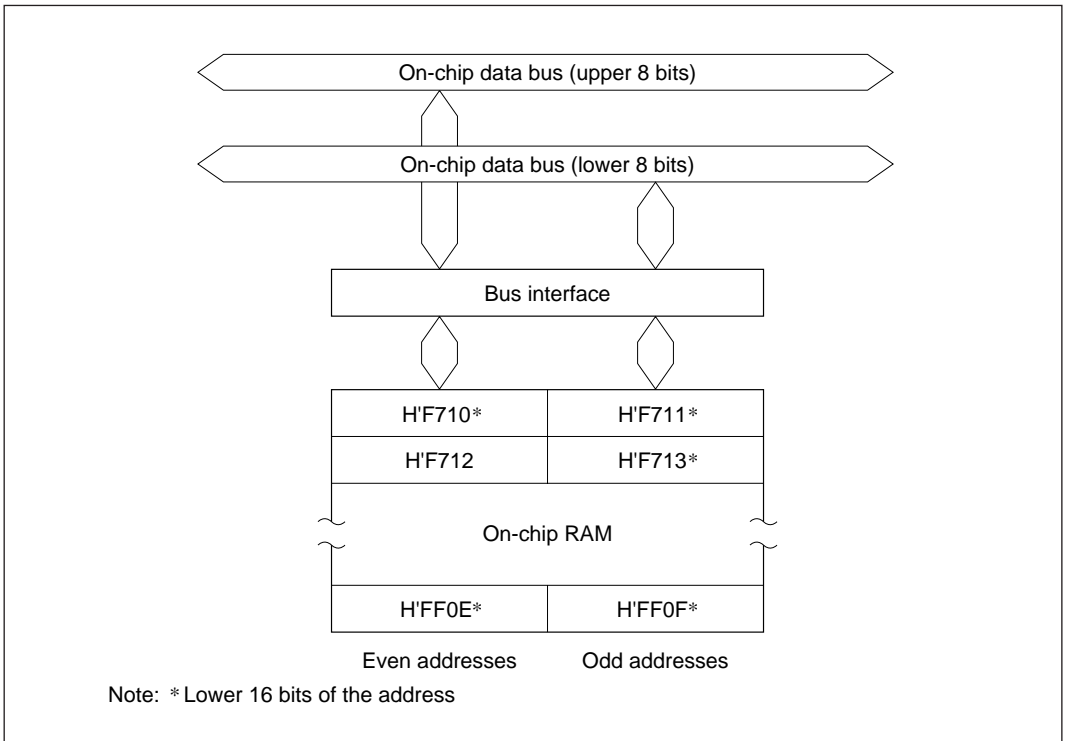
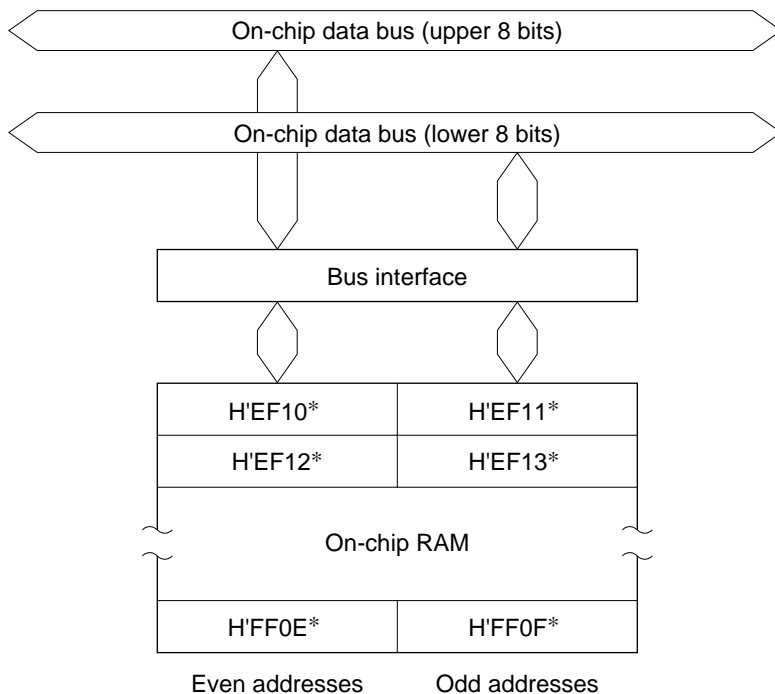

Figure 12-1 RAM Block Diagram (H8/3004)



Note: * Lower 16 bits of the address

Figure 12-2 RAM Block Diagram (H8/3005)

12.1.2 Register Configuration

The on-chip RAM is controlled by the system control register (SYSCR). Table 12-1 gives the address and initial value of SYSCR.

Table 12-1 RAM Control Register

Address*	Name	Abbreviation	R/W	Initial Value
H'FFF2	System control register	SYSCR	R/W	H'0B

Note: * Lower 16 bits of the address

12.2 System Control Register (SYSCR)

Bit	7	6	5	4	3	2	1	0
	SSBY	STS2	STS1	STS0	UE	NMIEG	—	RAME
Initial value	0	0	0	0	1	0	1	1
Read/Write	R/W	R/W	R/W	R/W	R/W	R/W	—	R/W

Software standby (Bit 7)
Standby timer select 2 to 0 (Bits 6, 5, 4)
User bit enable (Bit 3)
NMI edge select (Bit 2)
Reserved bit (Bit 1)
RAM enable bit (Bit 0)
 Enables or disables on-chip RAM

One function of SYSCR is to enable or disable access to the on-chip RAM. The on-chip RAM is enabled or disabled by the RAME bit in SYSCR. For details about the other bits, see section 3.3, System Control Register.

Bit 0—RAM Enable (RAME): Enables or disables the on-chip RAM. The RAME bit is initialized at the rising edge of the input at the RES pin. It is not initialized in software standby mode.

Bit 0

RAME	Description
0	On-chip RAM is disabled
1	On-chip RAM is enabled (Initial value)

12.3 Operation

When the RAME bit is set to 1, on-chip RAM is enabled. Accesses to addresses H'FF710 to H'FFF0F in the H8/3004, and to addresses H'FEF10 to H'FFF0F in the H8/3005, are directed to the on-chip RAM space. When the RAME bit is cleared to 0, accesses to such addresses are directed to external address space.

Section 13 Clock Pulse Generator

13.1 Overview

The H8/3004 and H8/3005 have a built-in clock pulse generator (CPG) that generates the system clock (ϕ) and other internal clock signals ($\phi/2$ to $\phi/4096$). The clock pulse generator consists of an oscillator circuit, a duty adjustment circuit, and prescalers.

13.1.1 Block Diagram

Figure 13-1 shows a block diagram of the clock pulse generator.

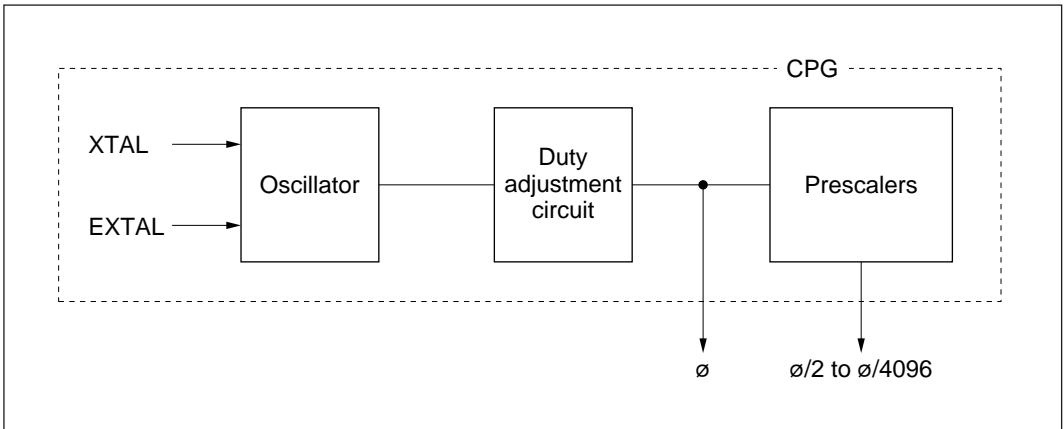

Figure 13-1 Block Diagram of Clock Pulse Generator

13.2 Oscillator Circuit

Clock pulses can be supplied by connecting a crystal resonator, or by input of an external clock signal.

13.2.1 Connecting a Crystal Resonator

Circuit Configuration: A crystal resonator can be connected as in the example in figure 13-2. The damping resistance R_d should be selected according to table 13-1. An AT-cut parallel-resonance crystal should be used.

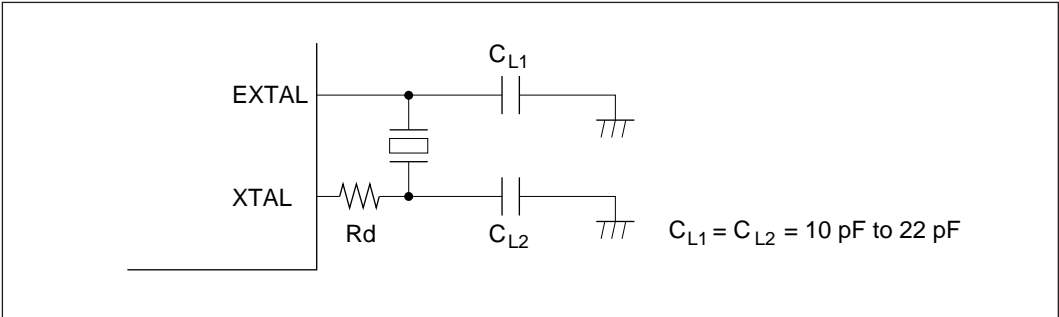

Figure 13-2 Connection of Crystal Resonator (Example)

Table 13-1 Damping Resistance Value

Frequency (MHz)	2	4	8	10	12	16
R_d (Ω)	1 k	500	200	0	0	0

Crystal Resonator: Figure 13-3 shows an equivalent circuit of the crystal resonator. The crystal resonator should have the characteristics listed in table 13-2.

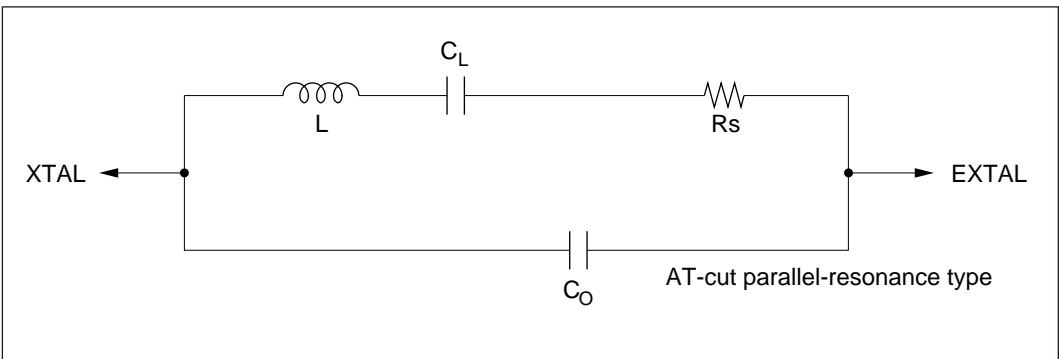

Figure 13-3 Crystal Resonator Equivalent Circuit

Table 13-2 Crystal Resonator Parameters

Frequency (MHz)	2	4	8	10	12	16
Rs max (Ω)	500	120	80	70	60	50
Co max (pF)	7					

Use a crystal resonator with a frequency equal to the system clock frequency (ϕ).

Notes on Board Design: When a crystal resonator is connected, the following points should be noted:

Other signal lines should be routed away from the oscillator circuit to prevent induction from interfering with correct oscillation. See figure 13-4.

When the board is designed, the crystal resonator and its load capacitors should be placed as close as possible to the XTAL and EXTAL pins.

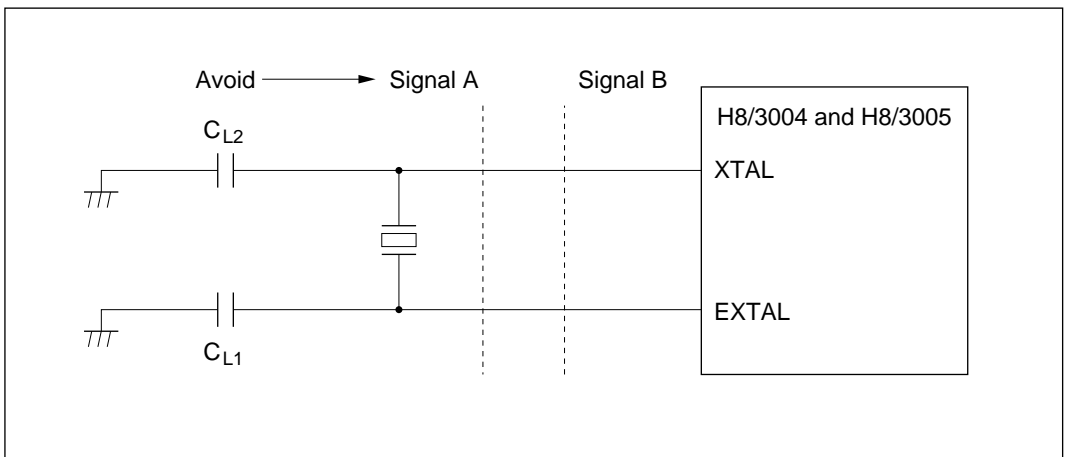
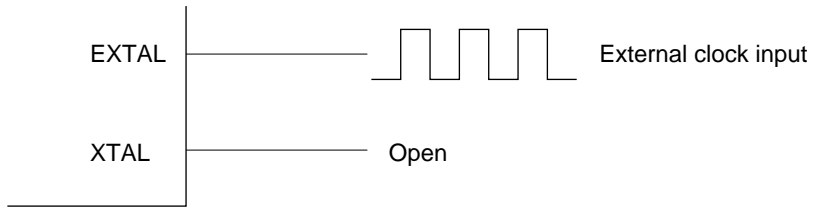

Figure 13-4 Example of Incorrect Board Design

13.2.2 External Clock Input

Circuit Configuration: An external clock signal can be input as shown in the examples in figure 13-5. In example b, the clock should be held high in standby mode.

If the XTAL pin is left open, the stray capacitance should not exceed 10 pF.



a. XTAL pin left open

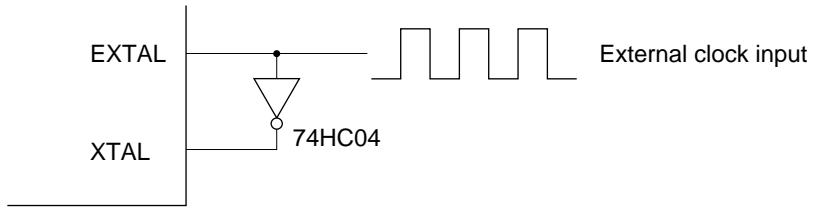

b. Complementary clock input at XTAL pin

Figure 13-5 External Clock Input (Examples)

External Clock: The external clock frequency should be equal to the system clock frequency (ϕ). Table 13-3 and figure 13-6 indicate the clock timing.

Table 13-3 Clock Timing

Item	Symbol	$V_{CC} = 2.7\text{ V to }5.5\text{ V}$		$V_{CC} = 5.0\text{ V} \pm 10\%$		Unit	Test Conditions
		Min	Max	Min	Max		
External clock rise time	t_{EXr}	—	10	—	5	ns	Figure 13-6
External clock fall time	t_{EXf}	—	10	—	5	ns	
External clock input duty (a/t_{cyc})	—	30	70	30	70	%	$\phi \geq 5\text{ MHz}$ $\phi < 5\text{ MHz}$
		40	60	40	60	%	
ϕ clock duty (b/t_{cyc})	—	40	60	40	60	%	$\phi \geq 5\text{ MHz}$

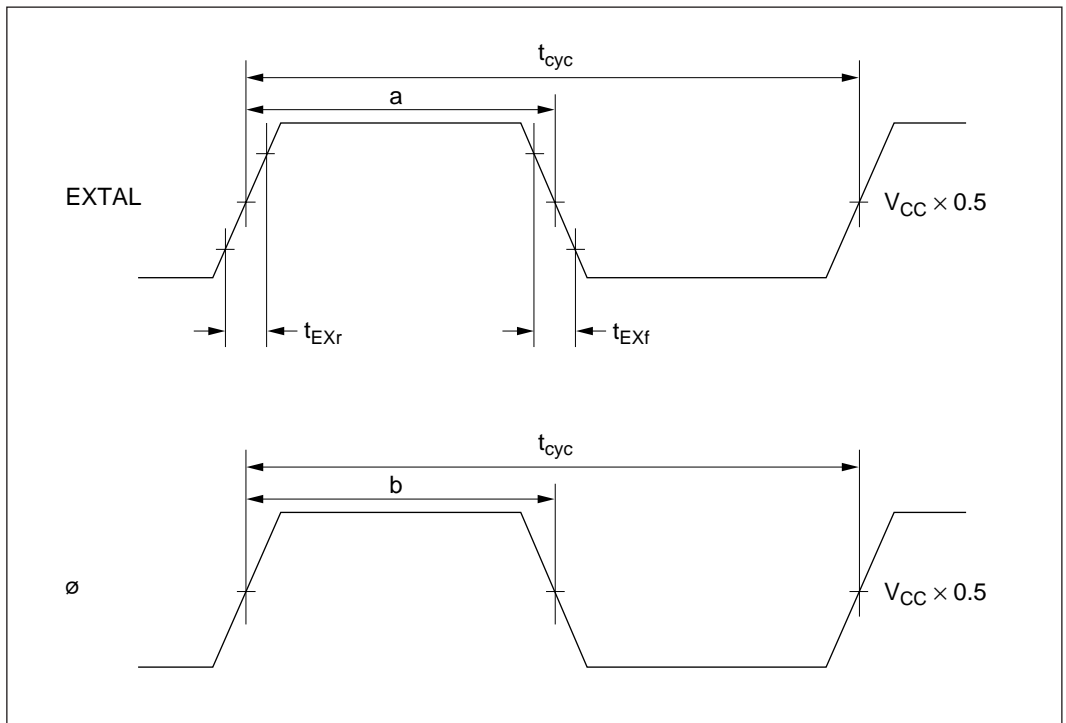

Figure 13-6 External Clock Input Timing

Figure 13-7 shows the timing for the external clock output stabilization delay time. The oscillator and duty correction circuit have the function of regulating the waveform of the external clock input to the EXTAL pin. When the specified clock signal is input to the EXTAL pin, internal clock signal output is confirmed after the elapse of the external clock output stabilization delay time (t_{DEXT}). As clock signal output is not confirmed during the t_{DEXT} period, the reset signal should be driven low and the reset state maintained during this time.

Conditions: $V_{\text{CC}} = 2.7$ to 5.5 V, $AV_{\text{CC}} = 2.7$ to 5.5 V, $V_{\text{SS}} = AV_{\text{SS}} = 0$ V

Item	Symbol	Min	Max	Unit	Notes
External clock output stabilization delay time	t_{DEXT}^*	500	—	μs	Figure 13-7

Note: * t_{DEXT} includes a $10 t_{\text{cyc}} \overline{\text{RES}}$ pulse width (t_{RESW}).

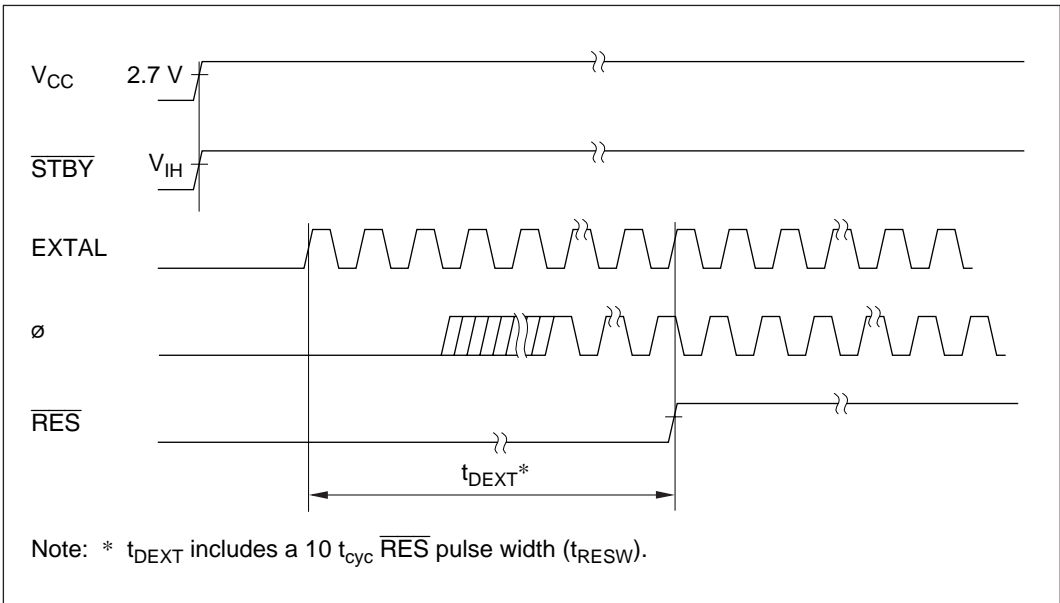

Figure 13-7 External Clock Output Stabilization Delay Time

13.3 Duty Adjustment Circuit

When the oscillator frequency is 5 MHz or higher, the duty adjustment circuit adjusts the duty cycle of the clock signal from the oscillator to generate the system clock (ϕ).

13.4 Prescalers

The prescalers divide the system clock (ϕ) to generate internal clocks ($\phi/2$ to $\phi/4096$).

Section 14 Power-Down State

14.1 Overview

The H8/3004 and H8/3005 have a power-down state that greatly reduces power consumption by halting CPU functions. The power-down state includes the following three modes:

- Sleep mode
- Software standby mode
- Hardware standby mode

Table 14-1 indicates the methods of entering and exiting these power-down modes and the status of the CPU and on-chip supporting modules in each mode.

Table 14-1 Power-Down State

Mode	Entering Conditions	State						Exiting Conditions
		Clock	CPU	CPU Registers	Supporting Functions	RAM	I/O Ports	
Sleep mode	SLEEP instruction executed while SSBY = 0 in SYSCR	Active	Halted	Held	Active	Held	Held	<ul style="list-style-type: none"> • Interrupt • \overline{RES} • \overline{STBY}
Software standby mode	SLEEP instruction executed while SSBY = 1 in SYSCR	Halted	Halted	Held	Halted and reset	Held	Held	<ul style="list-style-type: none"> • NMI • IRQ_0 to IRQ_2 • \overline{RES} • \overline{STBY}
Hardware standby mode	Low input at \overline{STBY} pin	Halted	Halted	Undetermined	Halted and reset	Held*	High impedance	<ul style="list-style-type: none"> • \overline{STBY} • \overline{RES}

Note: * The RAME bit must be cleared to 0 in SYSCR before the transition from the program execution state to hardware standby mode.

Legend

SYSCR: System control register

SSBY: Software standby bit

14.2 Register Configuration

The H8/3004 and H8/3005's system control register (SYSCR) controls the power-down state. Table 14-2 summarizes this register.

Table 14-2 Control Register

Address*	Name	Abbreviation	R/W	Initial Value
H'FFF2	System control register	SYSCR	R/W	H'0B

Note: * Lower 16 bits of the address.

14.2.1 System Control Register (SYSCR)

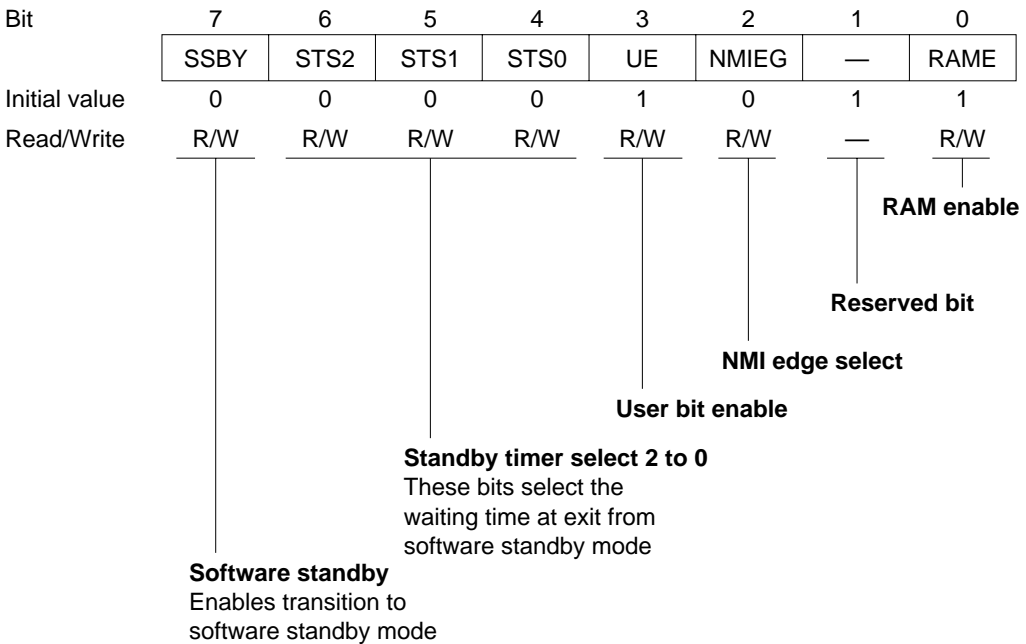

SYSCR is an 8-bit readable/writable register. Bit 7 (SSBY) and bits 6 to 4 (STS2 to STS0) control the power-down state. For information on the other SYSCR bits, see section 3.3, System Control Register.

Bit 7—Software Standby (SSBY): Enables transition to software standby mode. When software standby mode is exited by an external interrupt, this bit remains set to 1 after the return to normal operation. To clear this bit, write 0.

Bit 7

SSBY	Description	
0	SLEEP instruction causes transition to sleep mode	(Initial value)
1	SLEEP instruction causes transition to software standby mode	

Bits 6 to 4—Standby Timer Select (STS2 to STS0): These bits select the length of time the CPU and on-chip supporting modules wait for the clock to settle when software standby mode is exited by an external interrupt. If the clock is generated by a crystal resonator, set these bits according to the clock frequency so that the waiting time will be at least 8 ms. See table 14-3. If an external clock is used, any setting is permitted.

Bit 6 STS2	Bit 5 STS1	Bit 4 STS0	Description	
0	0	0	Waiting time = 8192 states	(Initial value)
		1	Waiting time = 16384 states	
	1	0	Waiting time = 32768 states	
		1	Waiting time = 65536 states	
1	0	—	Waiting time = 131072 states	
	1	—	Illegal setting	

14.3 Sleep Mode

14.3.1 Transition to Sleep Mode

When the SSBY bit is cleared to 0 in the system control register (SYSCR), execution of the SLEEP instruction causes a transition from the program execution state to sleep mode. Immediately after executing the SLEEP instruction the CPU halts, but the contents of its internal registers are retained. The on-chip supporting modules do not halt in sleep mode.

14.3.2 Exit from Sleep Mode

Sleep mode is exited by an interrupt, or by input at the $\overline{\text{RES}}$ or $\overline{\text{STBY}}$ pin.

Exit by Interrupt: An interrupt terminates sleep mode and causes a transition to the interrupt exception handling state. Sleep mode is not exited by an interrupt source in an on-chip supporting module if the interrupt is disabled in the on-chip supporting module. Sleep mode is not exited by an NMI interrupt if masked in the CPU.

Exit by $\overline{\text{RES}}$ Input: Low input at the $\overline{\text{RES}}$ pin exits from sleep mode to the reset state.

Exit by $\overline{\text{STBY}}$ Input: Low input at the $\overline{\text{STBY}}$ pin exits from sleep mode to hardware standby mode.

14.4 Software Standby Mode

14.4.1 Transition to Software Standby Mode

To enter software standby mode, execute the SLEEP instruction while the SSBY bit is set to 1 in SYSCR.

In software standby mode, current dissipation is reduced to an extremely low level because the CPU, clock, and on-chip supporting modules all halt. The on-chip supporting modules are reset. As long as the specified voltage is supplied, however, CPU register contents and on-chip RAM data are retained. The settings of the I/O ports are also held.

14.4.2 Exit from Software Standby Mode

Software standby mode can be exited by input of an external interrupt at the NMI, $\overline{\text{IRQ}}_0$, $\overline{\text{IRQ}}_1$, or $\overline{\text{IRQ}}_2$ pin, or by input at the $\overline{\text{RES}}$ or $\overline{\text{STBY}}$ pin.

Exit by Interrupt: When an NMI, IRQ_0 , IRQ_1 , or IRQ_2 interrupt request signal is received, the clock oscillator begins operating. After the oscillator settling time selected by bits STS2 to STS0 in SYSCR, stable clock signals are supplied to the entire H8/3004 and H8/3005 chip, software standby mode ends, and interrupt exception handling begins. Software standby mode is not exited if the interrupt enable bits of interrupts IRQ_0 , IRQ_1 , and IRQ_2 are cleared to 0, or if these interrupts are masked in the CPU.

Exit by $\overline{\text{RES}}$ Input: When the $\overline{\text{RES}}$ input goes low, the clock oscillator starts and clock pulses are supplied immediately to the entire H8/3004 and H8/3005 chip. The $\overline{\text{RES}}$ signal must be held low long enough for the clock oscillator to stabilize. When $\overline{\text{RES}}$ goes high, the CPU starts reset exception handling.

Exit by $\overline{\text{STBY}}$ Input: Low input at the $\overline{\text{STBY}}$ pin causes a transition to hardware standby mode.

14.4.3 Selection of Waiting Time for Exit from Software Standby Mode

Bits STS2 to STS0 in SYSCR should be set as follows.

Crystal Resonator: Set STS2 to STS0 so that the waiting time (for the clock to stabilize) is at least 8 ms. Table 14-3 indicates the waiting times that are selected by STS2 to STS0 settings at various system clock frequencies.

External Clock: Any value may be set in the clock-halving version. Normally the minimum value (STS2 = STS1 = STS0 = 1) is recommended. In the 1:1 clock version, any value other than the minimum value may be set.

Table 14-3 Clock Frequency and Waiting Time for Clock to Settle

STS2	STS1	STS0	Waiting Time	Clock Frequency							Unit
				16 MHz	12 MHz	10 MHz	8 MHz	6 MHz	4 MHz	2 MHz	
0	0	0	8192 states	0.51	0.65	0.8	1.0	1.3	2.0	4.1	ms
0	0	1	16384 states	1.0	1.3	1.6	2.0	2.7	4.1	8.2	
0	1	0	32768 states	2.0	2.7	3.3	4.1	5.5	8.2	16.4	
0	1	1	65536 states	4.1	5.5	6.6	8.2	10.9	16.4	32.8	
1	0	—	131072 states	8.2	10.9	13.1	16.4	21.8	32.8	65.5	
1	1	—	Illegal setting								

 : Recommended setting

Note: * This setting cannot be used in the 1:1 clock version.

14.4.4 Sample Application of Software Standby Mode

Figure 14-1 shows an example in which software standby mode is entered at the fall of NMI and exited at the rise of NMI.

With the NMI edge select bit (NMIEG) cleared to 0 in SYSCR (selecting the falling edge), an NMI interrupt occurs. Next the NMIEG bit is set to 1 (selecting the rising edge) and the SSBY bit is set to 1; then the SLEEP instruction is executed to enter software standby mode.

Software standby mode is exited at the next rising edge of the NMI signal .

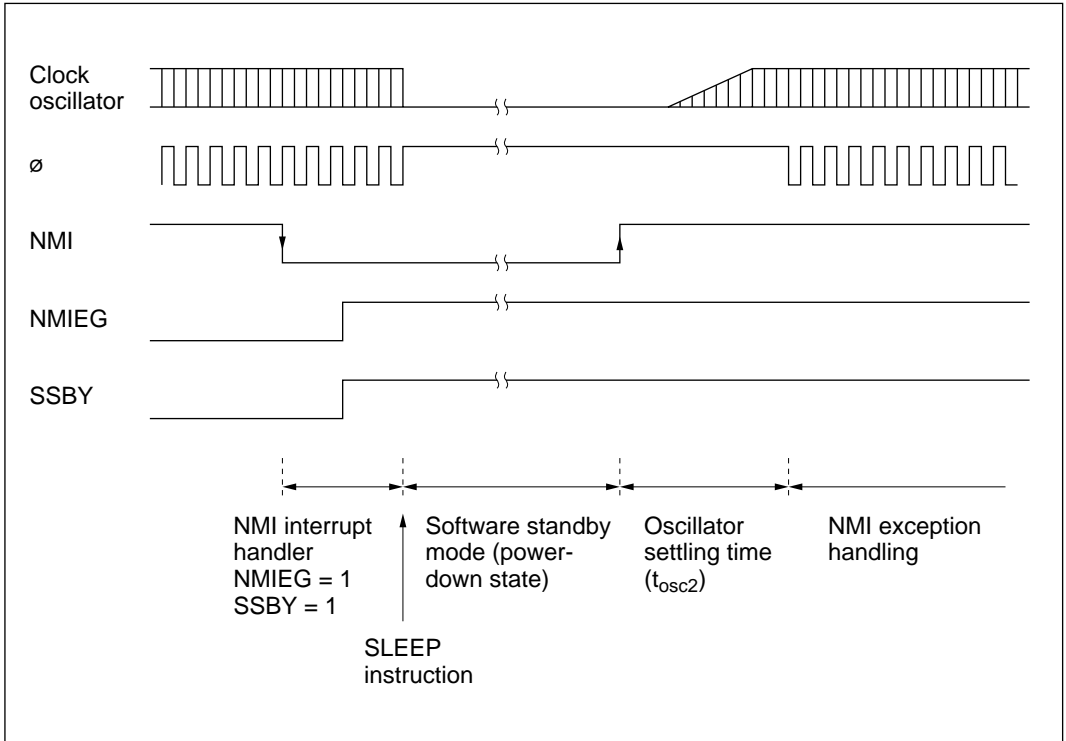

Figure 14-1 NMI Timing for Software Standby Mode (Example)

14.4.5 Note

The I/O ports retain their existing states in software standby mode. If a port is in the high output state, its output current is not reduced.

14.5 Hardware Standby Mode

14.5.1 Transition to Hardware Standby Mode

Regardless of its current state, the chip enters hardware standby mode whenever the $\overline{\text{STBY}}$ pin goes low. Hardware standby mode reduces power consumption drastically by halting all functions of the CPU and on-chip supporting modules. All modules are reset except the on-chip RAM. As long as the specified voltage is supplied, on-chip RAM data is retained. I/O ports are placed in the high-impedance state.

Clear the RAME bit to 0 in SYSCR before $\overline{\text{STBY}}$ goes low to retain on-chip RAM data.

The inputs at the mode pins (MD_1 to MD_0) should not be changed during hardware standby mode.

14.5.2 Exit from Hardware Standby Mode

Hardware standby mode is exited by inputs at the $\overline{\text{STBY}}$ and $\overline{\text{RES}}$ pins. While $\overline{\text{RES}}$ is low, when $\overline{\text{STBY}}$ goes high, the clock oscillator starts running. $\overline{\text{RES}}$ should be held low long enough for the clock oscillator to settle. When $\overline{\text{RES}}$ goes high, reset exception handling begins, followed by a transition to the program execution state.

14.5.3 Timing for Hardware Standby Mode

Figure 14-2 shows the timing relationships for hardware standby mode. To enter hardware standby mode, first drive $\overline{\text{RES}}$ low, then drive $\overline{\text{STBY}}$ low. To exit hardware standby mode, first drive $\overline{\text{STBY}}$ high, wait for the clock to settle, then bring $\overline{\text{RES}}$ from low to high.

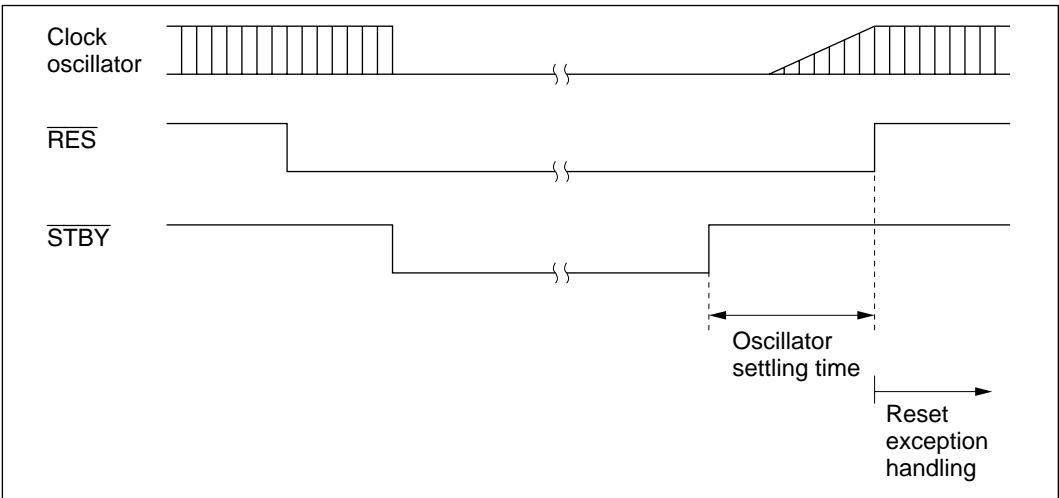

Figure 14-2 Hardware Standby Mode Timing

Section 15 Electrical Characteristics

15.1 Absolute Maximum Ratings

Table 15-1 lists the absolute maximum ratings.

Table 15-1 Absolute Maximum Ratings

—Preliminary—

Item	Symbol	Value	Unit
Power supply voltage	V_{CC}	−0.3 to +7.0	V
Input voltage (except port 7)	V_{IN}	−0.3 to $V_{CC} + 0.3$	V
Input voltage (port 7)	V_{IN}	−0.3 to $AV_{CC} + 0.3$	V
Reference voltage	V_{REF}	−0.3 to $AV_{CC} + 0.3$	V
Analog power supply voltage	AV_{CC}	−0.3 to +7.0	V
Analog input voltage	V_{AN}	−0.3 to $AV_{CC} + 0.3$	V
Operating temperature	T_{opr}	Regular specifications: −20 to +75	°C
		Wide-range specifications: −40 to +85	°C
Storage temperature	T_{stg}	−55 to +125	°C

Caution: Permanent damage to the chip may result if absolute maximum ratings are exceeded.

15.2 Electrical Characteristics

15.2.1 DC Characteristics

Table 15-2 lists the DC characteristics. Table 15-3 lists the permissible output currents.

Table 15-2 DC Characteristics

Conditions: $V_{CC} = 5.0\text{ V} \pm 10\%$, $AV_{CC} = 5.0\text{ V} \pm 10\%$, $V_{REF} = 4.5\text{ V}$ to AV_{CC} ,
 $V_{SS} = AV_{SS} = 0\text{ V}^*$, $T_a = -20^\circ\text{C}$ to $+75^\circ\text{C}$ (regular specifications),
 $T_a = -40^\circ\text{C}$ to $+85^\circ\text{C}$ (wide-range specifications)

Item	Symbol	Min	Typ	Max	Unit	Test Conditions	
Schmitt trigger input voltages	Port A,	V_{T-}	1.0	—	—	V	
	PB ₀ to PB ₂ ,	V_{T+}	—	—	$V_{CC} \times 0.7$	V	
	PB ₀ to PB ₃	$V_{T+} - V_{T-}$	0.4	—	—	V	
Input high voltage	\overline{RES} , \overline{STBY} , NMI, MD ₁ , MD ₀	V_{IH}	$V_{CC} - 0.7$	—	$V_{CC} + 0.3$	V	
	EXTAL		$V_{CC} \times 0.7$	—	$V_{CC} + 0.3$	V	
	Port 7		2.0	—	$AV_{CC} + 0.3\text{ V}$		
	Ports 6, 9, PB ₃ , PB ₄ to PB ₇ , D ₇ to D ₀		2.0	—	$V_{CC} + 0.3$	V	
Input low voltage	\overline{RES} , \overline{STBY} , MD ₁ , MD ₀	V_{IL}	-0.3	—	0.5	V	
	NMI, EXTAL, ports 6, 7, 9, PB ₃ , PB ₄ to PB ₇ , D ₇ to D ₀		-0.3	—	0.8	V	
Output high voltage	All output pins	V_{OH}	$V_{CC} - 0.5$	—	—	V	$I_{OH} = -200\ \mu\text{A}$
			3.5	—	—	V	$I_{OH} = -1\ \text{mA}$

Note: * If the A/D converter is not used, do not leave the AV_{CC} , AV_{SS} , and V_{REF} pins open. Connect AV_{CC} and V_{REF} to V_{CC} , and connect AV_{SS} to V_{SS} .

Table 15-2 DC Characteristics (cont)

Conditions: $V_{CC} = 5.0\text{ V} \pm 10\%$, $AV_{CC} = 5.0\text{ V} \pm 10\%$, $V_{REF} = 4.5\text{ V}$ to AV_{CC} ,
 $V_{SS} = AV_{SS} = 0\text{ V}^{*1}$, $T_a = -20^\circ\text{C}$ to $+75^\circ\text{C}$ (regular specifications),
 $T_a = -40^\circ\text{C}$ to $+85^\circ\text{C}$ (wide-range specifications)

Item	Symbol	Min	Typ	Max	Unit	Test Conditions
Output low voltage	All output pins (except $\overline{RES0}$)	V_{OL}	—	—	0.4	V $I_{OL} = 1.6\text{ mA}$
	Ports B, A_{19} to A_0		—	—	1.0	V $I_{OL} = 10\text{ mA}$
	$\overline{RES0}$		—	—	0.4	V $I_{OL} = 2.6\text{ mA}$
Input leakage current	\overline{STBY} , \overline{NMI} , \overline{RES} , $\overline{MD1}$, $\overline{MD0}$	$ I_{IN} $	—	—	1.0	μA $V_{IN} = 0.5$ to $V_{CC} - 0.5\text{ V}$
	Port 7		—	—	1.0	μA $V_{IN} = 0.5$ to $AV_{CC} - 0.5\text{ V}$
Three-state leakage current (off state)	Ports 6, 8 to B, A_{19} to A_0 , D_7 to D_0	$ I_{TS1} $	—	—	1.0	μA $V_{IN} = 0.5$ to $V_{CC} - 0.5\text{ V}$
	$\overline{RES0}$		—	—	10.0	μA
Input capacitance	\overline{NMI}	C_{IN}	—	—	50	pF $V_{IN} = 0\text{ V}$ $f = 1\text{ MHz}$ $T_a = 25^\circ\text{C}$
	All input pins except \overline{NMI}		—	—	15	
Current dissipation*2	Normal operation	I_{CC}	—	45	60	mA $f = 16\text{ MHz}$
	Sleep mode		—	32	45	mA $f = 16\text{ MHz}$
	Standby mode*3		—	0.01	5.0	μA $T_a \leq 50^\circ\text{C}$
			—	—	20.0	μA $50^\circ\text{C} < T_a$

- Notes: 1. If the A/D converter is not used, do not leave the AV_{CC} , AV_{SS} , and V_{REF} pins open. Connect AV_{CC} and V_{REF} to V_{CC} , and connect AV_{SS} to V_{SS} .
2. Current dissipation values are for $V_{IHmin} = V_{CC} - 0.5\text{ V}$ and $V_{ILmax} = 0.5\text{ V}$ with all output pins unloaded and the on-chip pull-up transistors in the off state.
3. The values are for $V_{RAM} \leq V_{CC} < 4.5\text{ V}$, $V_{IHmin} = V_{CC} \times 0.9$, and $V_{ILmax} = 0.3\text{ V}$.

Table 15-2 DC Characteristics (cont)

Conditions: $V_{CC} = 5.0\text{ V} \pm 10\%$, $AV_{CC} = 5.0\text{ V} \pm 10\%$, $V_{REF} = 4.5\text{ V}$ to AV_{CC} ,
 $V_{SS} = AV_{SS} = 0\text{ V}^*$, $T_a = -20^\circ\text{C}$ to $+75^\circ\text{C}$ (regular specifications),
 $T_a = -40^\circ\text{C}$ to $+85^\circ\text{C}$ (wide-range specifications)

Item		Symbol	Min	Typ	Max	Unit	Test Conditions
Analog power supply current	During A/D conversion	AI_{CC}	—	1.2	2.0	mA	
	Idle		—	0.01	5.0	μA	
Reference current	During A/D conversion	AI_{CC}	—	0.3	0.6	mA	$V_{REF} = 5.0\text{ V}$
	Idle		—	0.01	5.0	μA	
RAM standby voltage		V_{RAM}	2.0	—	—	V	

- Notes: 1. If the A/D converter is not used, do not leave the AV_{CC} , AV_{SS} , and V_{REF} pins open. Connect AV_{CC} and V_{REF} to V_{CC} , and connect AV_{SS} to V_{SS} .
2. Current dissipation values are for $V_{IHmin} = V_{CC} - 0.5\text{ V}$ and $V_{ILmax} = 0.5\text{ V}$ with all output pins unloaded and the on-chip pull-up transistors in the off state.
3. The values are for $V_{RAM} < V_{CC} < 4.5\text{ V}$, $V_{IHmin} = V_{CC} \times 0.9$, and $V_{ILmax} = 0.3\text{ V}$.

Conditions: $V_{CC} = 2.7\text{ V}$ to 5.5 V , $AV_{CC} = 2.7\text{ V}$ to 5.5 V , $V_{REF} = 2.7\text{ V}$ to AV_{CC} ,
 $V_{SS} = AV_{SS} = 0\text{ V}^*$, $T_a = -20^\circ\text{C}$ to $+75^\circ\text{C}$ (regular specifications),
 $T_a = -40^\circ\text{C}$ to $+85^\circ\text{C}$ (wide-range specifications)

Item		Symbol	Min	Typ	Max	Unit	Test Conditions
Schmitt trigger input voltages	Port A,	V_{T-}	$V_{CC} \times 0.2$	—	—	V	
	P8 ₀ to P8 ₂ , PB ₀ to PB ₃	V_{T+}	—	—	$V_{CC} \times 0.7$	V	
		$V_{T+} - V_{T-}$	$V_{CC} \times 0.07$	—	—	V	
Input high voltage	\overline{RES} , \overline{STBY} , NMI, MD ₁ , MD ₀	V_{IH}	$V_{CC} \times 0.9$	—	$V_{CC} + 0.3$	V	
	EXTAL		$V_{CC} \times 0.7$	—	$V_{CC} + 0.3$	V	
	Port 7		$V_{CC} \times 0.7$	—	$AV_{CC} + 0.3$	V	
	Ports 6, 9, P8 ₃ , PB ₄ to PB ₇ , D ₇ to D ₀		$V_{CC} \times 0.7$	—	$V_{CC} + 0.3$	V	

Note: * If the A/D converter is not used, do not leave the AV_{CC} , AV_{SS} , and V_{REF} pins open. Connect AV_{CC} and V_{REF} to V_{CC} , and connect AV_{SS} to V_{SS} .

Table 15-2 DC Characteristics (cont)

Conditions: $V_{CC} = 2.7\text{ V to }5.5\text{ V}$, $AV_{CC} = 2.7\text{ V to }5.5\text{ V}$, $V_{REF} = 2.7\text{ V to }AV_{CC}$,
 $V_{SS} = AV_{SS} = 0\text{ V}^*$, $T_a = -20^\circ\text{C to }+75^\circ\text{C}$ (regular specifications),
 $T_a = -40^\circ\text{C to }+85^\circ\text{C}$ (wide-range specifications)

Item	Symbol	Min	Typ	Max	Unit	Test Conditions	
Input low voltage	\overline{RES} , \overline{STBY} , MD ₁ , MD ₀	V_{IL}	-0.3	—	$V_{CC} \times 0.1$	V	
	NMI, EXTAL, ports 6, 7, 9, P8 ₃ , PB ₄ to PB ₇ , D ₇ to D ₀		-0.3	—	$V_{CC} \times 0.2$ 0.8	V V	$V_{CC} < 4.0\text{ V}$ $V_{CC} = 4.0\text{ to }5.5\text{ V}$
Output high voltage	All output pins	V_{OH}	$V_{CC} - 0.5$	—	—	V	$I_{OH} = -200\ \mu\text{A}$
			$V_{CC} - 1.0$	—	—	V	$I_{OH} = -1\ \text{mA}$
Output low voltage	All output pins (except \overline{RESO})	V_{OL}	—	—	0.4	V	$I_{OL} = 1.6\ \text{mA}$
	Ports B, A ₁₉ to A ₀		—	—	1.0	V	$V_{CC} \leq 4\text{ V}$, $I_{OL} = 5\ \text{mA}$, $4\text{ V} \leq V_{CC} \leq 5.5\text{ V}$, $I_{OL} = 10\ \text{mA}$
	\overline{RESO}		—	—	0.4	V	$I_{OL} = 1.6\ \text{mA}$
Input leakage current	\overline{STBY} , NMI, \overline{RES} , MD ₁ , MD ₀	$ I_{IN} $	—	—	1.0	μA	$V_{IN} = 0.5\text{ to }V_{CC} - 0.5\text{ V}$
	Port 7		—	—	1.0	μA	$V_{IN} = 0.5\text{ to }AV_{CC} - 0.5\text{ V}$
Three-state leakage current (off state)	Ports 6, 8 to B, A ₁₉ to A ₀ , D ₇ to D ₀	$ I_{TS1} $	—	—	1.0	μA	$V_{IN} = 0.5\text{ to }V_{CC} - 0.5\text{ V}$
	\overline{RESO}		—	—	10.0	μA	

Note: * If the A/D converter is not used, do not leave the AV_{CC} , AV_{SS} , and V_{REF} pins open. Connect AV_{CC} and V_{REF} to V_{CC} , and connect AV_{SS} to V_{SS} .

Table 15-2 DC Characteristics (cont)

Conditions: $V_{CC} = 2.7\text{ V to }5.5\text{ V}$, $AV_{CC} = 2.7\text{ V to }5.5\text{ V}$, $V_{REF} = 2.7\text{ V to }AV_{CC}$,
 $V_{SS} = AV_{SS} = 0\text{ V}^{*1}$, $T_a = -20^\circ\text{C to }+75^\circ\text{C}$ (regular specifications),
 $T_a = -40^\circ\text{C to }+85^\circ\text{C}$ (wide-range specifications)

Item		Symbol	Min	Typ	Max	Unit	Test Conditions
Input capacitance	NMI	C_{IN}	—	—	50	pF	$V_{IN} = 0\text{ V}$ $f = 1\text{ MHz}$ $T_a = 25^\circ\text{C}$
	All input pins except NMI		—	—	15		
Current dissipation*2	Normal operation	I_{CC}^{*4}	—	12 (3.0 V)	33.8 (5.5 V)	mA	$f = 8\text{ MHz}$
	Sleep mode		—	8 (3.0 V)	25.0 (5.5 V)	mA	$f = 8\text{ MHz}$
	Standby mode*3		—	0.01	5.0	μA	$T_a \leq 50^\circ\text{C}$
Analog power supply current	During A/D conversion	AI_{CC}	—	1.0	2.0	mA	$AV_{CC} = 3.0\text{ V}$
			—	1.2	—	mA	$AV_{CC} = 5.0\text{ V}$
	Idle		—	0.01	5.0	μA	
Reference current	During A/D conversion	AI_{CC}	—	0.2	0.4	mA	$V_{REF} = 3.0\text{ V}$
			—	0.3	—	mA	$V_{REF} = 5.0\text{ V}$
	Idle		—	0.01	5.0	μA	
RAM standby voltage		V_{RAM}	2.0	—	—	V	

- Notes: 1. If the A/D converter is not used, do not leave the AV_{CC} , AV_{SS} , and V_{REF} pins open. Connect AV_{CC} and V_{REF} to V_{CC} , and connect AV_{SS} to V_{SS} .
2. Current dissipation values are for $V_{IHmin} = V_{CC} - 0.5\text{ V}$ and $V_{ILmax} = 0.5\text{ V}$ with all output pins unloaded.
3. The values are for $V_{RAM} \leq V_{CC} < 2.7\text{ V}$, $V_{IHmin} = V_{CC} \times 0.9$, and $V_{ILmax} = 0.3\text{ V}$.
4. I_{CC} depends on V_{CC} and f as follows:
 $I_{CCmax} = 3.0\text{ (mA)} + 0.7\text{ (mA/MHz} \cdot \text{V)} \times V_{CC} \times f$ [normal mode]
 $I_{CCmax} = 3.0\text{ (mA)} + 0.5\text{ (mA/MHz} \cdot \text{V)} \times V_{CC} \times f$ [sleep mode]

Table 15-2 DC Characteristics (cont)

Conditions: $V_{CC} = 3.0\text{ V to }5.5\text{ V}$, $AV_{CC} = 3.0\text{ V to }5.5\text{ V}$, $V_{REF} = 3.0\text{ V to }AV_{CC}$,
 $V_{SS} = AV_{SS} = 0\text{ V}^*$, $T_a = -20^\circ\text{C to }+75^\circ\text{C}$ (regular specifications),
 $T_a = -40^\circ\text{C to }+85^\circ\text{C}$ (wide-range specifications)

Item		Symbol	Min	Typ	Max	Unit	Test Conditions
Schmitt trigger input voltages	Port A,	V_{T^-}	$V_{CC} \times 0.2$	—	—	V	
	P8 ₀ to P8 ₂ , PB ₀ to PB ₃	V_{T^+}	—	—	$V_{CC} \times 0.7$	V	
		$V_{T^+} - V_{T^-}$	$V_{CC} \times 0.07$	—	—	V	
Input high voltage	\overline{RES} , \overline{STBY} , NMI, MD ₁ , MD ₀	V_{IH}	$V_{CC} \times 0.9$	—	$V_{CC} + 0.3$	V	
	EXTAL		$V_{CC} \times 0.7$	—	$V_{CC} + 0.3$	V	
	Port 7		$V_{CC} \times 0.7$	—	$AV_{CC} + 0.3$	V	
	Ports 6, 9, P8 ₃ , PB ₄ to PB ₇ , D ₇ to D ₀		$V_{CC} \times 0.7$	—	$V_{CC} + 0.3$	V	
Input low voltage	\overline{RES} , \overline{STBY} , MD ₁ , MD ₀	V_{IL}	-0.3	—	$V_{CC} \times 0.1$	V	
	NMI, EXTAL, ports 6, 7, 9, P8 ₃ , PB ₄ to PB ₇ , D ₇ to D ₀		-0.3	—	$V_{CC} \times 0.2$ 0.8	V	$V_{CC} < 4.0\text{ V}$ $V_{CC} = 4.0\text{ to }5.5\text{ V}$
Output high voltage	All output pins	V_{OH}	$V_{CC} - 0.5$	—	—	V	$I_{OH} = -200\ \mu\text{A}$
			$V_{CC} - 1.0$	—	—	V	$I_{OH} = -1\ \text{mA}$

Note: * If the A/D converter is not used, do not leave the AV_{CC} , AV_{SS} , and V_{REF} pins open. Connect AV_{CC} and V_{REF} to V_{CC} , and connect AV_{SS} to V_{SS} .

Table 15-2 DC Characteristics (cont)

Conditions: $V_{CC} = 3.0\text{ V to }5.5\text{ V}$, $AV_{CC} = 3.0\text{ V to }5.5\text{ V}$, $V_{REF} = 3.0\text{ V to }AV_{CC}$,
 $V_{SS} = AV_{SS} = 0\text{ V}^*$, $T_a = -20^\circ\text{C to }+75^\circ\text{C}$ (regular specifications),
 $T_a = -40^\circ\text{C to }+85^\circ\text{C}$ (wide-range specifications)

Item	Symbol	Min	Typ	Max	Unit	Test Conditions
Output low voltage	All output pins (except $\overline{\text{RESO}}$)	V_{OL}	—	—	0.4	V $I_{OL} = 1.6\text{ mA}$
	Ports B, A_{19} to A_0	—	—	1.0	V	$V_{CC} \leq 4\text{ V}$ $I_{OL} = 5\text{ mA}$, $4\text{ V} < V_{CC} \leq 5.5\text{ V}$ $I_{OL} = 10\text{ mA}$
	$\overline{\text{RESO}}$	—	—	0.4	V	$I_{OL} = 1.6\text{ mA}$
Input leakage current	$\overline{\text{STBY}}$, $\overline{\text{NMI}}$, $\overline{\text{RES}}$, MD_1 , MD_0	$ I_{IN} $	—	—	1.0	μA $V_{IN} = 0.5$ to $V_{CC} - 0.5\text{ V}$
	Port 7	—	—	1.0	μA	$V_{IN} = 0.5$ to $AV_{CC} - 0.5\text{ V}$
Three-state leakage current (off state)	Ports 6, 8 to B, A_{19} to A_0 , D_7 to D_0	$ I_{TS1} $	—	—	1.0	μA $V_{IN} = 0.5$ to $V_{CC} - 0.5\text{ V}$
	$\overline{\text{RESO}}$	—	—	10.0	μA	$V_{IN} = 0.5$ to $V_{CC} - 0.5\text{ V}$

Note: * If the A/D converter is not used, do not leave the AV_{CC} , AV_{SS} , and V_{REF} pins open. Connect AV_{CC} and V_{REF} to V_{CC} , and connect AV_{SS} to V_{SS} .

Table 15-2 DC Characteristics (cont)

Conditions: $V_{CC} = 3.0\text{ V to }5.5\text{ V}$, $AV_{CC} = 3.0\text{ V to }5.5\text{ V}$, $V_{REF} = 3.0\text{ V to }AV_{CC}$,
 $V_{SS} = AV_{SS} = 0\text{ V}^{*1}$, $T_a = -20^{\circ}\text{C to }+75^{\circ}\text{C}$ (regular specifications),
 $T_a = -40^{\circ}\text{C to }+85^{\circ}\text{C}$ (wide-range specifications)

Item		Symbol	Min	Typ	Max	Unit	Test Conditions
Input capacitance	NMI	C_{IN}	—	—	50	pF	$V_{IN} = 0\text{ V}$ $f = 1\text{ MHz}$ $T_a = 25^{\circ}\text{C}$
	All input pins except NMI		—	—	15		
Current dissipation*2	Normal operation	I_{CC}^{*4}	—	15 (3.0 V)	41.5 (5.5 V)	mA	$f = 10\text{ MHz}$
	Sleep mode		—	10 (3.0 V)	30.5 (5.5 V)	mA	$f = 10\text{ MHz}$
	Standby mode*3		—	0.01	5.0	μA	$T_a \leq 50^{\circ}\text{C}$
			—	—	20.0	μA	$50^{\circ}\text{C} < T_a$
Analog power supply current	During A/D conversion	AI_{CC}	—	1.0	2.0	mA	$AV_{CC} = 3.0\text{ V}$
			—	1.2	—	mA	$AV_{CC} = 5.0\text{ V}$
	Idle		—	0.01	5.0	μA	
Reference current	During A/D conversion	AI_{CC}	—	0.2	0.4	mA	$V_{REF} = 3.0\text{ V}$
			—	0.3	—	mA	$V_{REF} = 5.0\text{ V}$
	Idle		—	0.01	5.0	μA	
RAM standby voltage		V_{RAM}	2.0	—	—	V	

- Notes: 1. If the A/D converter is not used, do not leave the AV_{CC} , AV_{SS} , and V_{REF} pins open. Connect AV_{CC} and V_{REF} to V_{CC} , and connect AV_{SS} to V_{SS} .
2. Current dissipation values are for $V_{IHmin} = V_{CC} - 0.5\text{ V}$ and $V_{ILmax} = 0.5\text{ V}$ with all output pins unloaded.
3. The values are for $V_{RAM} \leq V_{CC} < 3.0\text{ V}$, $V_{IHmin} = V_{CC} \times 0.9$, and $V_{ILmax} = 0.3\text{ V}$.
4. I_{CC} depends on V_{CC} and f as follows:
 $I_{CCmax} = 3.0\text{ (mA)} + 0.7\text{ (mA/MHz} \cdot \text{V)} \times V_{CC} \times f$ [normal mode]
 $I_{CCmax} = 3.0\text{ (mA)} + 0.5\text{ (mA/MHz} \cdot \text{V)} \times V_{CC} \times f$ [sleep mode]

Table 15-3 Permissible Output Currents

Conditions: $V_{CC} = 2.7\text{ V to }5.5\text{ V}$, $AV_{CC} = 2.7\text{ V to }5.5\text{ V}$, $V_{REF} = 2.7\text{ V to }AV_{CC}$,
 $V_{SS} = AV_{SS} = 0\text{ V}$, $T_a = -20^\circ\text{C to }+75^\circ\text{C}$ (regular specifications),
 $T_a = -40^\circ\text{C to }+85^\circ\text{C}$ (wide-range specifications)

Item		Symbol	Min	Typ	Max	Unit
Permissible output low current (per pin)	Ports B, A ₁₉ to A ₀	I_{OL}	—	—	10	mA
	Other output pins		—	—	2.0	mA
Permissible output low current (total)	Total of 28 pins including ports B, A ₁₉ to A ₀	ΣI_{OL}	—	—	80	mA
	Total of all output pins, including the above		—	—	120	mA
Permissible output high current (per pin)	All output pins	I_{OH}	—	—	2.0	mA
Permissible output high current (total)	Total of all output pins	ΣI_{OH}	—	—	40	mA

- Notes: 1. To protect chip reliability, do not exceed the output current values in table 15-3.
2. When driving a darlington pair or LED, always insert a current-limiting resistor in the output line, as shown in figures 15-1 and 15-2.

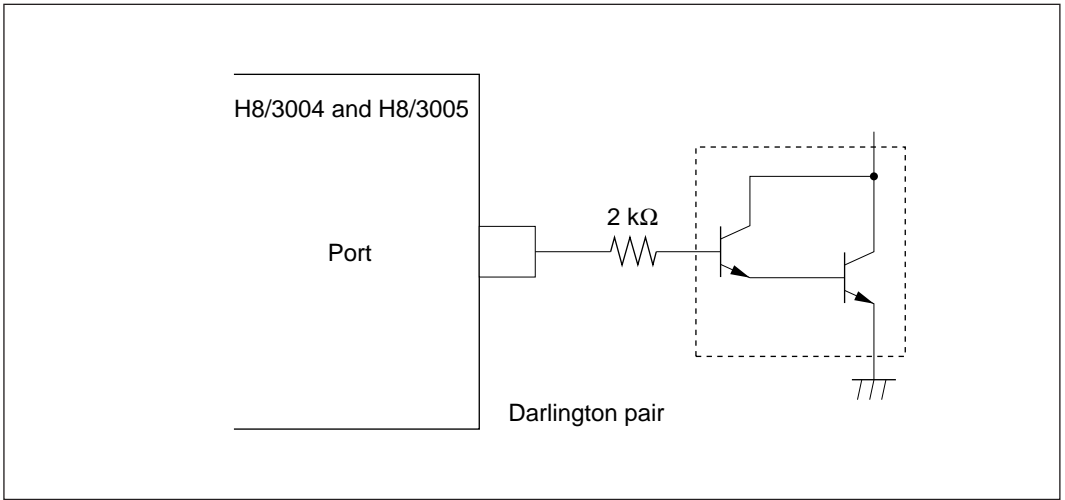

Figure 15-1 Darlington Pair Drive Circuit (Example)

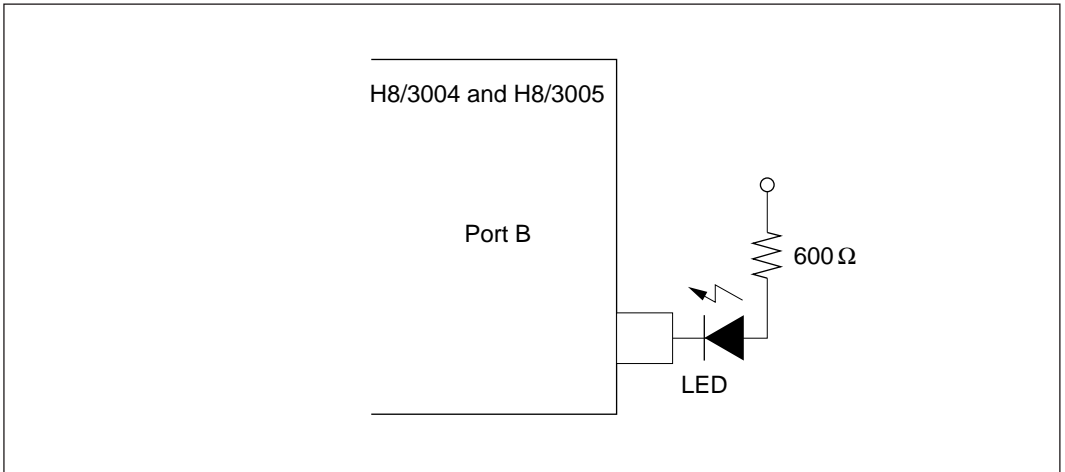

Figure 15-2 LED Drive Circuit (Example)

15.2.2 AC Characteristics

Bus timing parameters are listed in table 15-4. Control signal timing parameters are listed in table 15-5. Timing parameters of the on-chip supporting modules are listed in table 15-6.

Table 15-4 Bus Timing

Condition A: $V_{CC} = 2.7\text{ V to }5.5\text{ V}$, $AV_{CC} = 2.7\text{ V to }5.5\text{ V}$, $V_{REF} = 2.7\text{ V to }AV_{CC}$,
 $V_{SS} = AV_{SS} = 0\text{ V}$, $\phi = 2\text{ MHz to }8\text{ MHz}$, $T_a = -20^\circ\text{C to }+75^\circ\text{C}$ (regular specifications), $T_a = -40^\circ\text{C to }+85^\circ\text{C}$ (wide-range specifications)

Condition B: $V_{CC} = 3.0\text{ V to }5.5\text{ V}$, $AV_{CC} = 3.0\text{ V to }5.5\text{ V}$, $V_{REF} = 3.0\text{ V to }AV_{CC}$,
 $V_{SS} = AV_{SS} = 0\text{ V}$, $\phi = 2\text{ MHz to }10\text{ MHz}$, $T_a = -20^\circ\text{C to }+75^\circ\text{C}$ (regular specifications), $T_a = -40^\circ\text{C to }+85^\circ\text{C}$ (wide-range specifications)

Condition C: $V_{CC} = 5.0\text{ V} \pm 10\%$, $AV_{CC} = 5.0\text{ V} \pm 10\%$, $V_{REF} = 4.5\text{ V to }AV_{CC}$,
 $V_{SS} = AV_{SS} = 0\text{ V}$, $\phi = 2\text{ MHz to }16\text{ MHz}$, $T_a = -20^\circ\text{C to }+75^\circ\text{C}$ (regular specifications), $T_a = -40^\circ\text{C to }+85^\circ\text{C}$ (wide-range specifications)

Item	Symbol	Condition A		Condition B		Condition C		Unit	Test Conditions
		8 MHz		10 MHz		16 MHz			
		Min	Max	Min	Max	Min	Max		
Clock cycle time	t_{CYC}	125	500	100	500	62.5	500	ns	Figure 15-4, Figure 15-5
Clock low pulse width	t_{CL}	40	—	30	—	20	—		
Clock high pulse width	t_{CH}	40	—	30	—	20	—		
Clock rise time	t_{CR}	—	20	—	15	—	10		
Clock fall time	t_{CF}	—	20	—	15	—	10		
Address delay time	t_{AD}	—	60	—	50	—	30		
Address hold time	t_{AH}	25	—	20	—	10	—		
Address strobe delay time	t_{ASD}	—	60	—	40	—	30		
Write strobe delay time	t_{WSD}	—	60	—	50	—	30		
Strobe delay time	t_{SD}	—	60	—	50	—	30		
Write data strobe pulse width 1	t_{WSW1*}	85	—	60	—	35	—		
Write data strobe pulse width 2	t_{WSW2*}	150	—	110	—	65	—		
Address setup time 1	t_{AS1}	20	—	15	—	10	—		
Address setup time 2	t_{AS2}	80	—	65	—	40	—		
Read data setup time	t_{RDS}	50	—	35	—	20	—		
Read data hold time	t_{RDH}	0	—	0	—	0	—		

Table 15-4 Bus Timing (cont)

Condition A: $V_{CC} = 2.7\text{ V to }5.5\text{ V}$, $AV_{CC} = 2.7\text{ V to }5.5\text{ V}$, $V_{REF} = 2.7\text{ V to }AV_{CC}$,
 $V_{SS} = AV_{SS} = 0\text{ V}$, $\phi = 2\text{ MHz to }8\text{ MHz}$, $T_a = -20^\circ\text{C to }+75^\circ\text{C}$ (regular specifications), $T_a = -40^\circ\text{C to }+85^\circ\text{C}$ (wide-range specifications)

Condition B: $V_{CC} = 3.0\text{ V to }5.5\text{ V}$, $AV_{CC} = 3.0\text{ V to }5.5\text{ V}$, $V_{REF} = 3.0\text{ V to }AV_{CC}$,
 $V_{SS} = AV_{SS} = 0\text{ V}$, $\phi = 2\text{ MHz to }10\text{ MHz}$, $T_a = -20^\circ\text{C to }+75^\circ\text{C}$ (regular specifications), $T_a = -40^\circ\text{C to }+85^\circ\text{C}$ (wide-range specifications)

Condition C: $V_{CC} = 5.0\text{ V} \pm 10\%$, $AV_{CC} = 5.0\text{ V} \pm 10\%$, $V_{REF} = 4.5\text{ V to }AV_{CC}$,
 $V_{SS} = AV_{SS} = 0\text{ V}$, $\phi = 2\text{ MHz to }16\text{ MHz}$, $T_a = -20^\circ\text{C to }+75^\circ\text{C}$ (regular specifications), $T_a = -40^\circ\text{C to }+85^\circ\text{C}$ (wide-range specifications)

Item	Symbol	Condition A		Condition B		Condition C		Unit	Test Conditions
		8 MHz		10 MHz		16 MHz			
		Min	Max	Min	Max	Min	Max		
Write data delay time	t_{WDD}	—	75	—	75	—	60	ns	Figure 15-4, Figure 15-5
Write data setup time 1	t_{WDS1}	60	—	40	—	15	—		
Write data setup time 2	t_{WDS2}	5	—	-10	—	-5	—		
Write data hold time	t_{WDH}	25	—	20	—	20	—		
Read data access time 1	t_{ACC1*}	—	110	—	100	—	55		
Read data access time 2	t_{ACC2*}	—	230	—	200	—	115		
Read data access time 3	t_{ACC3*}	—	55	—	50	—	25		
Read data access time 4	t_{ACC4*}	—	160	—	150	—	85		
Precharge time	t_{PCH*}	85	—	60	—	40	—		
Wait setup time	t_{WTS}	40	—	40	—	25	—	ns	Figure 15-6
Wait hold time	t_{WTH}	10	—	10	—	5	—		

Note is on next page.

Note: At 8 MHz, the times below depend as indicated on the clock cycle time.

$$\begin{aligned}t_{ACC1} &= 1.5 \times t_{cyc} - 78 \text{ (ns)} & t_{WSW1} &= 1.0 \times t_{cyc} - 40 \text{ (ns)} \\t_{ACC2} &= 2.5 \times t_{cyc} - 83 \text{ (ns)} & t_{WSW2} &= 1.5 \times t_{cyc} - 38 \text{ (ns)} \\t_{ACC3} &= 1.0 \times t_{cyc} - 70 \text{ (ns)} & t_{PCH} &= 1.0 \times t_{cyc} - 40 \text{ (ns)} \\t_{ACC4} &= 2.0 \times t_{cyc} - 90 \text{ (ns)}\end{aligned}$$

At 10 MHz, the times below depend as indicated on the clock cycle time.

$$\begin{aligned}t_{ACC1} &= 1.5 \times t_{cyc} - 50 \text{ (ns)} & t_{WSW1} &= 1.0 \times t_{cyc} - 40 \text{ (ns)} \\t_{ACC2} &= 2.5 \times t_{cyc} - 50 \text{ (ns)} & t_{WSW2} &= 1.5 \times t_{cyc} - 40 \text{ (ns)} \\t_{ACC3} &= 1.0 \times t_{cyc} - 50 \text{ (ns)} & t_{PCH} &= 1.0 \times t_{cyc} - 40 \text{ (ns)} \\t_{ACC4} &= 2.0 \times t_{cyc} - 50 \text{ (ns)}\end{aligned}$$

At 16 MHz, the times below depend as indicated on the clock cycle time.

$$\begin{aligned}t_{ACC1} &= 1.5 \times t_{cyc} - 39 \text{ (ns)} & t_{WSW1} &= 1.0 \times t_{cyc} - 28 \text{ (ns)} \\t_{ACC2} &= 2.5 \times t_{cyc} - 41 \text{ (ns)} & t_{WSW2} &= 1.5 \times t_{cyc} - 28 \text{ (ns)} \\t_{ACC3} &= 1.0 \times t_{cyc} - 38 \text{ (ns)} & t_{PCH} &= 1.0 \times t_{cyc} - 23 \text{ (ns)} \\t_{ACC4} &= 2.0 \times t_{cyc} - 40 \text{ (ns)}\end{aligned}$$

Table 15-5 Control Signal Timing

Condition A: $V_{CC} = 2.7\text{ V to }5.5\text{ V}$, $AV_{CC} = 2.7\text{ V to }5.5\text{ V}$, $V_{REF} = 2.7\text{ V to }AV_{CC}$,
 $V_{SS} = 0\text{ V}$, $\phi = 2\text{ MHz to }8\text{ MHz}$, $T_a = -20^\circ\text{C to }+75^\circ\text{C}$ (regular specifications),
 $T_a = -40^\circ\text{C to }+85^\circ\text{C}$ (wide-range specifications)

Condition B: $V_{CC} = 3.0\text{ V to }5.5\text{ V}$, $AV_{CC} = 3.0\text{ V to }5.5\text{ V}$, $V_{REF} = 3.0\text{ V to }AV_{CC}$,
 $V_{SS} = AV_{SS} = 0\text{ V}$, $\phi = 2\text{ MHz to }10\text{ MHz}$, $T_a = -20^\circ\text{C to }+75^\circ\text{C}$ (regular specifications),
 $T_a = -40^\circ\text{C to }+85^\circ\text{C}$ (wide-range specifications)

Condition C: $V_{CC} = 5.0\text{ V} \pm 10\%$, $AV_{CC} = 5.0\text{ V} \pm 10\%$, $V_{REF} = 4.5\text{ V to }AV_{CC}$,
 $V_{SS} = AV_{SS} = 0\text{ V}$, $\phi = 2\text{ MHz to }16\text{ MHz}$, $T_a = -20^\circ\text{C to }+75^\circ\text{C}$ (regular specifications),
 $T_a = -40^\circ\text{C to }+85^\circ\text{C}$ (wide-range specifications)

Item	Symbol	Condition A		Condition B		Condition C		Unit	Test Conditions
		8 MHz		10 MHz		16 MHz			
		Min	Max	Min	Max	Min	Max		
$\overline{\text{RES}}$ setup time	t_{RESS}	200	—	200	—	200	—	ns	Figure 15-7
$\overline{\text{RES}}$ pulse width	t_{RESW}	10	—	10	—	10	—	t_{CYC}	
$\overline{\text{RESO}}$ output delay time	t_{RESD}	—	100	—	100	—	100	ns	Figure 15-8
$\overline{\text{RESO}}$ output pulse width	t_{RESOW}	132	—	132	—	132	—	t_{CYC}	
NMI setup time (NMI, $\overline{\text{IRQ}}_4$ to $\overline{\text{IRQ}}_0$)	t_{NMIS}	200	—	200	—	150	—	ns	Figure 15-9
NMI hold time (NMI, $\overline{\text{IRQ}}_4$ to $\overline{\text{IRQ}}_0$)	t_{NMIH}	10	—	10	—	10	—		
Interrupt pulse width (NMI, $\overline{\text{IRQ}}_4$ to $\overline{\text{IRQ}}_0$ when exiting software standby mode)	t_{NMIW}	200	—	200	—	200	—		
Clock oscillator settling time at reset (crystal)	t_{OSC1}	20	—	20	—	20	—	ms	Figure 15-10
Clock oscillator settling time in software standby (crystal)	t_{OSC2}	8	—	8	—	8	—	ms	Figure 14-1

Table 15-6 Timing of On-Chip Supporting Modules

Condition A: $V_{CC} = 2.7\text{ V to }5.5\text{ V}$, $AV_{CC} = 2.7\text{ V to }5.5\text{ V}$, $V_{REF} = 2.7\text{ V to }AV_{CC}$,
 $V_{SS} = AV_{SS} = 0\text{ V}$, $\phi = 2\text{ MHz to }8\text{ MHz}$, $T_a = -20^\circ\text{C to }+75^\circ\text{C}$ (regular specifications),
 $T_a = -40^\circ\text{C to }+85^\circ\text{C}$ (wide-range specifications)

Condition B: $V_{CC} = 3.0\text{ V to }5.5\text{ V}$, $AV_{CC} = 3.0\text{ V to }5.5\text{ V}$, $V_{REF} = 3.0\text{ V to }AV_{CC}$,
 $V_{SS} = 0\text{ V}$, $\phi = 2\text{ MHz to }10\text{ MHz}$, $T_a = -20^\circ\text{C to }+75^\circ\text{C}$ (regular specifications),
 $T_a = -40^\circ\text{C to }+85^\circ\text{C}$ (wide-range specifications)

Condition C: $V_{CC} = 5.0\text{ V} \pm 10\%$, $AV_{CC} = 5.0\text{ V} \pm 10\%$, $V_{REF} = 4.5\text{ V to }AV_{CC}$,
 $V_{SS} = AV_{SS} = 0\text{ V}$, $\phi = 2\text{ MHz to }16\text{ MHz}$, $T_a = -20^\circ\text{C to }+75^\circ\text{C}$ (regular specifications),
 $T_a = -40^\circ\text{C to }+85^\circ\text{C}$ (wide-range specifications)

Item	Symbol	Condition A		Condition B		Condition C		Unit	Test Conditions		
		8 MHz		10 MHz		16 MHz					
		Min	Max	Min	Max	Min	Max				
ITU	Timer output delay time	t_{TODC}	—	100	—	100	—	100	ns	Figure 15-12	
	Timer input setup time	t_{TICS}	50	—	50	—	50	—			
	Timer clock input setup time	t_{TCKS}	50	—	50	—	50	—		Figure 15-13	
	Timer clock pulse width	Single edge	t_{TCKWH}	1.5	—	1.5	—	1.5	—		t_{CYC}
		Both edges	t_{TCKWL}	2.5	—	2.5	—	2.5	—		
SCI	Input clock cycle	Asynchronous	t_{SCYC}	4	—	4	—	4	—	Figure 15-14	
		Synchronous	t_{SCYC}	6	—	6	—	6	—		
	Input clock rise time	t_{SCKr}	—	1.5	—	1.5	—	1.5			
	Input clock fall time	t_{SCKf}	—	1.5	—	1.5	—	1.5			
	Input clock pulse width	t_{SCKW}	0.4	0.6	0.4	0.6	0.4	0.6	t_{SCYC}		

Table 15-6 Timing of On-Chip Supporting Modules (cont)

Condition A: $V_{CC} = 2.7\text{ V to }5.5\text{ V}$, $AV_{CC} = 2.7\text{ V to }5.5\text{ V}$, $V_{REF} = 2.7\text{ V to }AV_{CC}$,
 $V_{SS} = 0\text{ V}$, $\phi = 2\text{ MHz to }8\text{ MHz}$, $T_a = -20^\circ\text{C to }+75^\circ\text{C}$ (regular specifications),
 $T_a = -40^\circ\text{C to }+85^\circ\text{C}$ (wide-range specifications)

Condition B: $V_{CC} = 3.0\text{ V to }5.5\text{ V}$, $AV_{CC} = 3.0\text{ V to }5.5\text{ V}$, $V_{REF} = 3.0\text{ V to }AV_{CC}$,
 $V_{SS} = AV_{SS} = 0\text{ V}$, $\phi = 2\text{ MHz to }10\text{ MHz}$, $T_a = -20^\circ\text{C to }+75^\circ\text{C}$ (regular specifications),
 $T_a = -40^\circ\text{C to }+85^\circ\text{C}$ (wide-range specifications)

Condition C: $V_{CC} = 5.0\text{ V} \pm 10\%$, $AV_{CC} = 5.0\text{ V} \pm 10\%$, $V_{REF} = 4.5\text{ V to }AV_{CC}$,
 $V_{SS} = AV_{SS} = 0\text{ V}$, $\phi = 2\text{ MHz to }16\text{ MHz}$, $T_a = -20^\circ\text{C to }+75^\circ\text{C}$ (regular specifications),
 $T_a = -40^\circ\text{C to }+85^\circ\text{C}$ (wide-range specifications)

Item	Symbol	Condition A		Condition B		Condition C		Unit	Test Conditions	
		8 MHz		10 MHz		16 MHz				
		Min	Max	Min	Max	Min	Max			
SCI	Transmit data delay time	t_{TXD}	—	100	—	100	—	100	ns	Figure 15-15
	Receive data setup time (synchronous)	t_{RXS}	100	—	100	—	100	—		
	Receive data hold time (synchronous clock input)	t_{RXH}	100	—	100	—	100	—		
	Receive data hold time (synchronous clock output)	t_{RXH}	0	—	0	—	0	—		
Ports	Output data delay time	t_{PWD}	—	100	—	100	—	100	ns	Figure 15-11
	Input data setup time (synchronous)	t_{PRS}	50	—	50	—	50	—		
	Input data hold time (synchronous)	t_{PRH}	50	—	50	—	50	—		

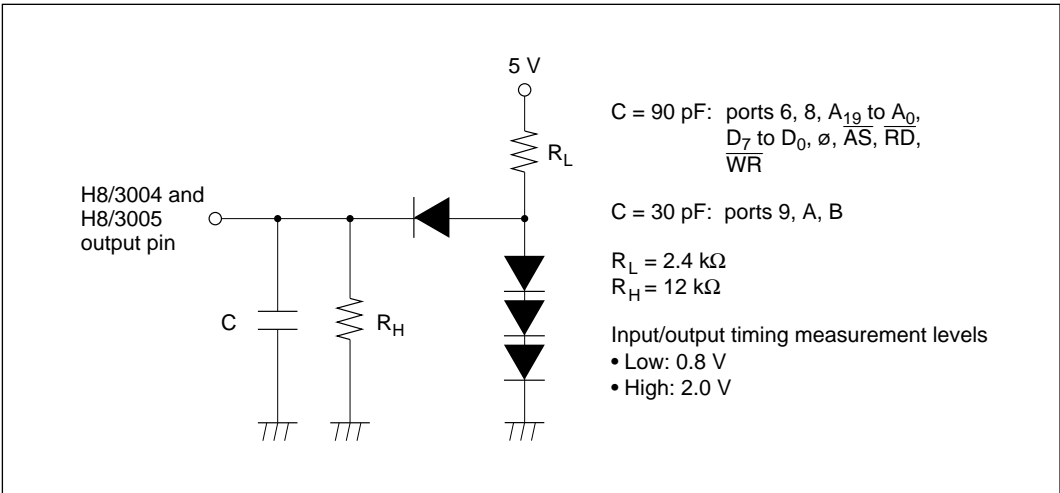

Figure 15-3 Output Load Circuit

15.2.3 A/D Conversion Characteristics

Table 15-7 lists the A/D conversion characteristics.

Table 15-7 A/D Converter Characteristics

Condition A: $V_{CC} = 2.7\text{ V to }5.5\text{ V}$, $AV_{CC} = 2.7\text{ V to }5.5\text{ V}$, $V_{REF} = 2.7\text{ V to }AV_{CC}$,
 $V_{SS} = AV_{SS} = 0\text{ V}$, $\phi = 2\text{ MHz to }8\text{ MHz}$, $T_a = -20^\circ\text{C to }+75^\circ\text{C}$ (regular specifications), $T_a = -40^\circ\text{C to }+85^\circ\text{C}$ (wide-range specifications)

Condition B: $V_{CC} = 3.0\text{ V to }5.5\text{ V}$, $AV_{CC} = 3.0\text{ V to }5.5\text{ V}$, $V_{REF} = 3.0\text{ V to }AV_{CC}$,
 $V_{SS} = AV_{SS} = 0\text{ V}$, $\phi = 2\text{ MHz to }10\text{ MHz}$, $T_a = -20^\circ\text{C to }+75^\circ\text{C}$ (regular specifications), $T_a = -40^\circ\text{C to }+85^\circ\text{C}$ (wide-range specifications)

Condition C: $V_{CC} = 5.0\text{ V} \pm 10\%$, $AV_{CC} = 5.0\text{ V} \pm 10\%$, $V_{REF} = 4.5\text{ V to }AV_{CC}$,
 $V_{SS} = AV_{SS} = 0\text{ V}$, $\phi = 2\text{ MHz to }16\text{ MHz}$, $T_a = -20^\circ\text{C to }+75^\circ\text{C}$ (regular specifications), $T_a = -40^\circ\text{C to }+85^\circ\text{C}$ (wide-range specifications)

Item	Condition A			Condition B			Condition C			Unit
	8 MHz			10 MHz			16 MHz			
	Min	Typ	Max	Min	Typ	Max	Min	Typ	Max	
Resolution	10	10	10	10	10	10	10	10	10	bits
Conversion time	—	—	16.8	—	—	13.4	—	—	8.4	μs
Analog input capacitance	—	—	20	—	—	20	—	—	20	pF
Permissible signal-source impedance	—	—	10*1	—	—	10*1	—	—	10*4	$\text{k}\Omega$
	—	—	5*2	—	—	5*3	—	—	5*5	
Nonlinearity error	—	—	± 6.0	—	—	± 6.0	—	—	± 3.0	LSB
Offset error	—	—	± 4.0	—	—	± 4.0	—	—	± 2.0	LSB
Full-scale error	—	—	± 4.0	—	—	± 4.0	—	—	± 2.0	LSB
Quantization error	—	—	± 0.5	—	—	± 0.5	—	—	± 0.5	LSB
Absolute accuracy	—	—	± 8.0	—	—	± 8.0	—	—	± 4.0	LSB

- Notes: 1. The value is for $4.0 \leq AV_{CC} \leq 5.5$.
2. The value is for $2.7 \leq AV_{CC} < 4.0$.
3. The value is for $3.0 \leq AV_{CC} < 4.0$.
4. The value is for $\phi \leq 12\text{ MHz}$.
5. The value is for $\phi > 12\text{ MHz}$.

15.3 Operational Timing

This section shows timing diagrams.

15.3.1 Bus Timing

Bus timing is shown as follows:

- Basic bus cycle: two-state access

Figure 15-4 shows the timing of the external two-state access cycle.

- Basic bus cycle: three-state access

Figure 15-5 shows the timing of the external three-state access cycle.

- Basic bus cycle: three-state access with one wait state

Figure 15-6 shows the timing of the external three-state access cycle with one wait state inserted.

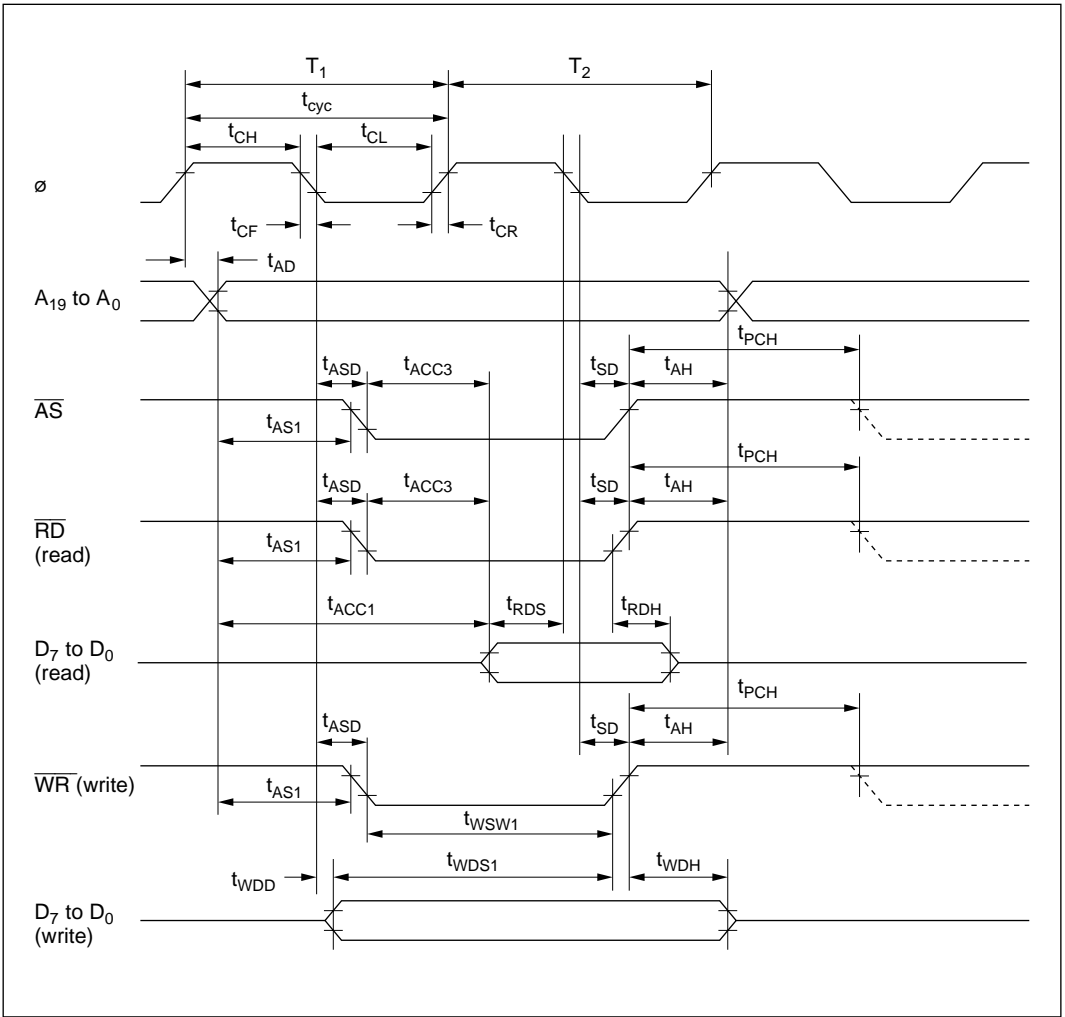

Figure 15-4 Basic Bus Cycle: Two-State Access

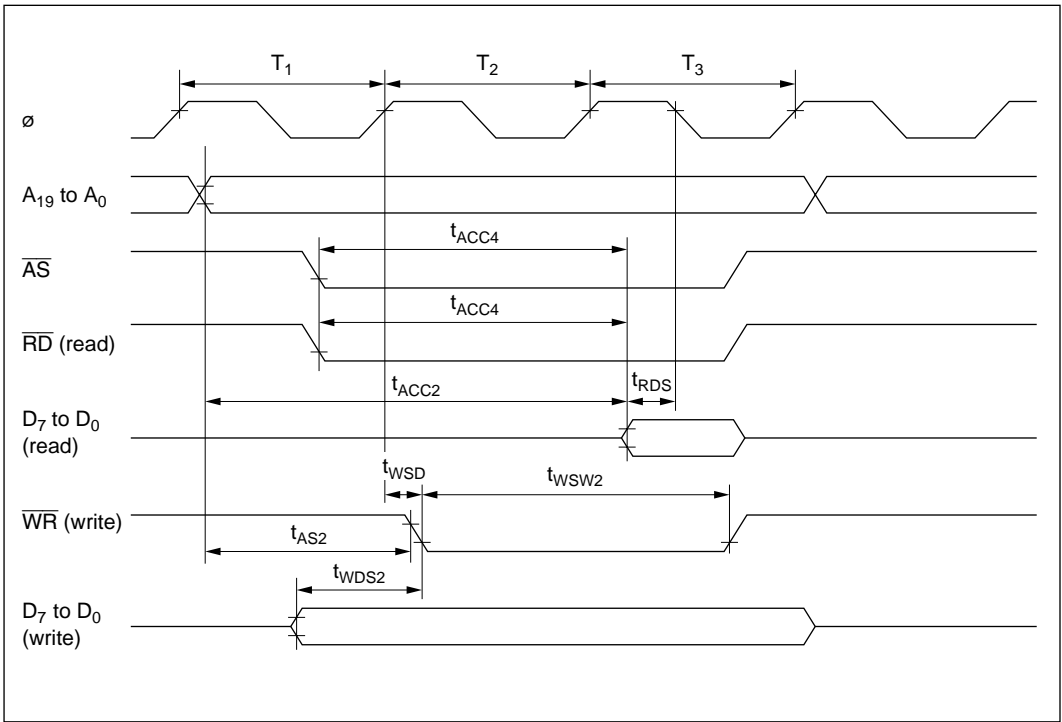

Figure 15-5 Basic Bus Cycle: Three-State Access

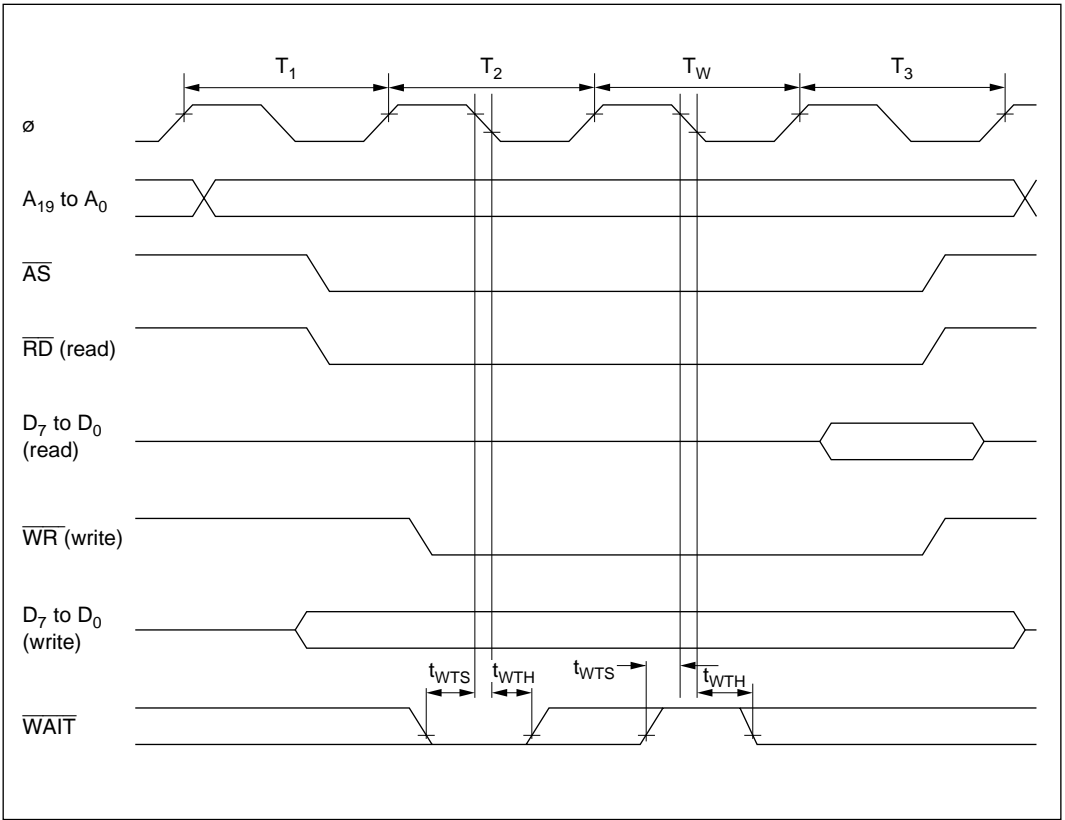

Figure 15-6 Basic Bus Cycle: Three-State Access with One Wait State

15.3.2 Control Signal Timing

Control signal timing is shown as follows:

- Reset input timing

Figure 15-7 shows the reset input timing.

- Reset output timing

Figure 15-8 shows the reset output timing.

- Interrupt input timing

Figure 15-9 shows the input timing for NMI and \overline{IRQ}_4 to \overline{IRQ}_0 .

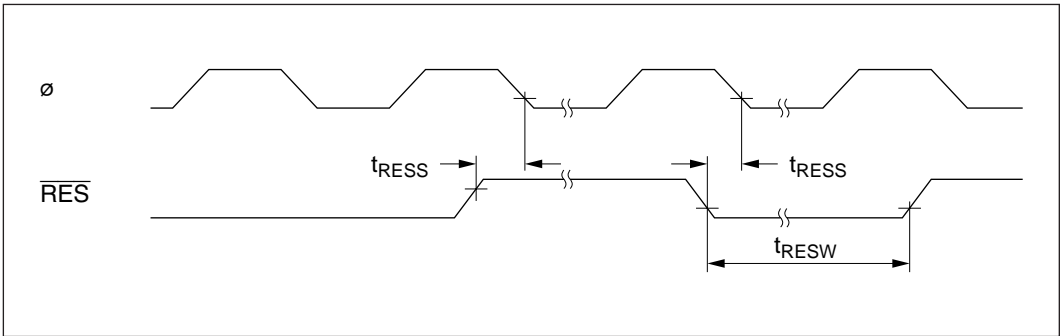

Figure 15-7 Reset Input Timing

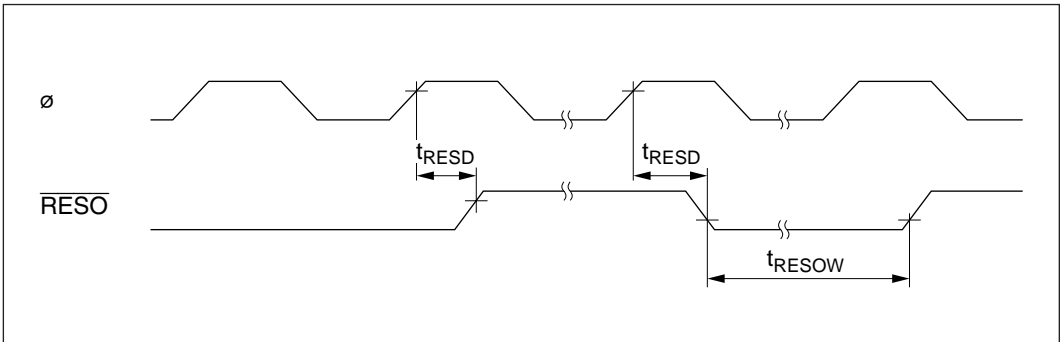

Figure 15-8 Reset Output Timing

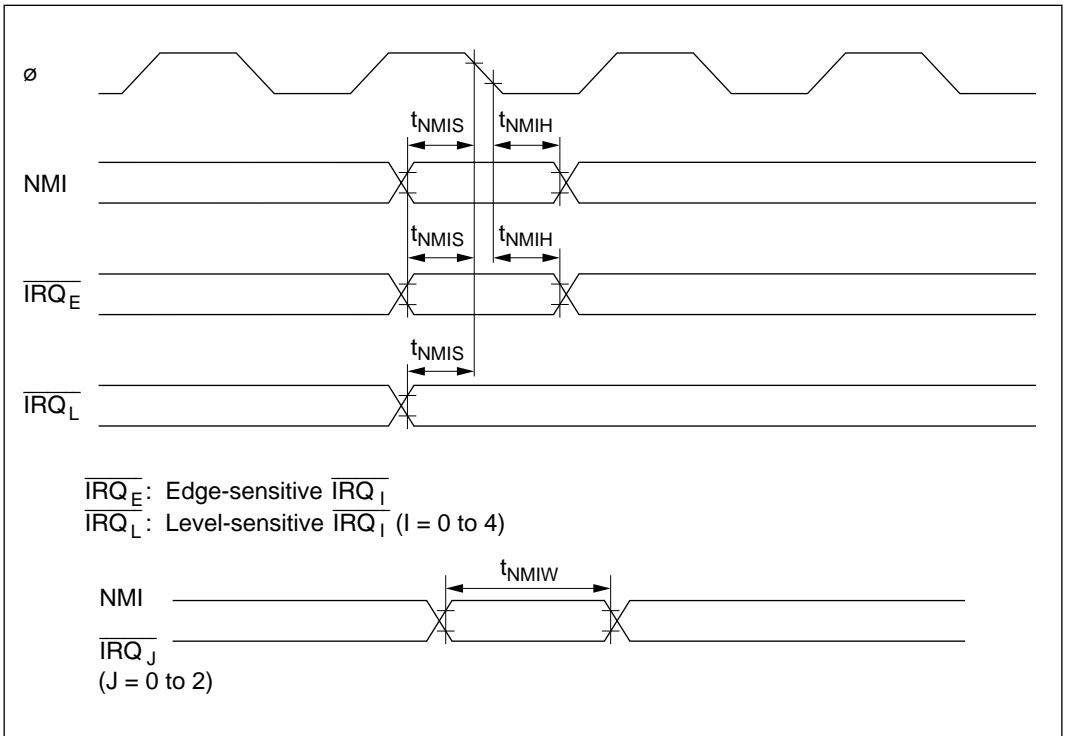

Figure 15-9 Interrupt Input Timing

15.3.3 Clock Timing

Clock timing is shown as follows:

- Oscillator settling timing

Figure 15-10 shows the oscillator settling timing.

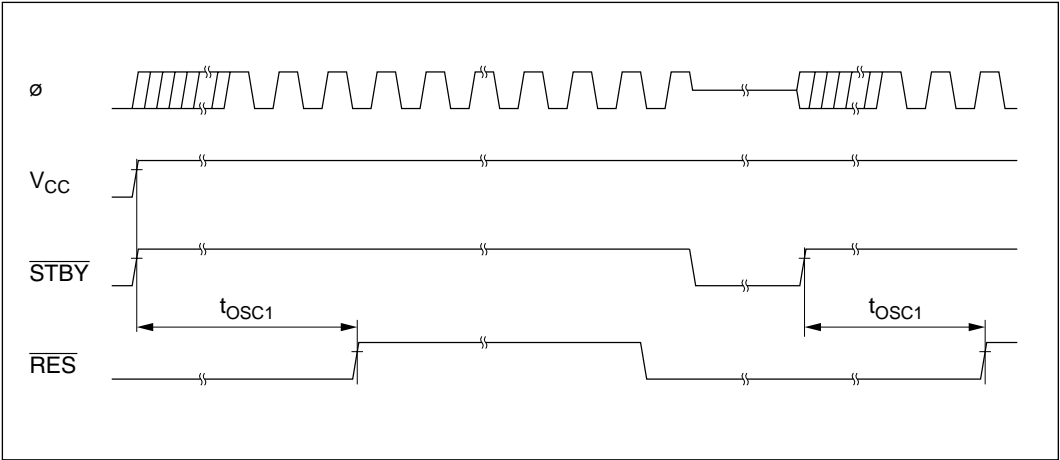

Figure 15-10 Oscillator Settling Timing

15.3.4 I/O Port Timing

I/O port timing is shown as follows.

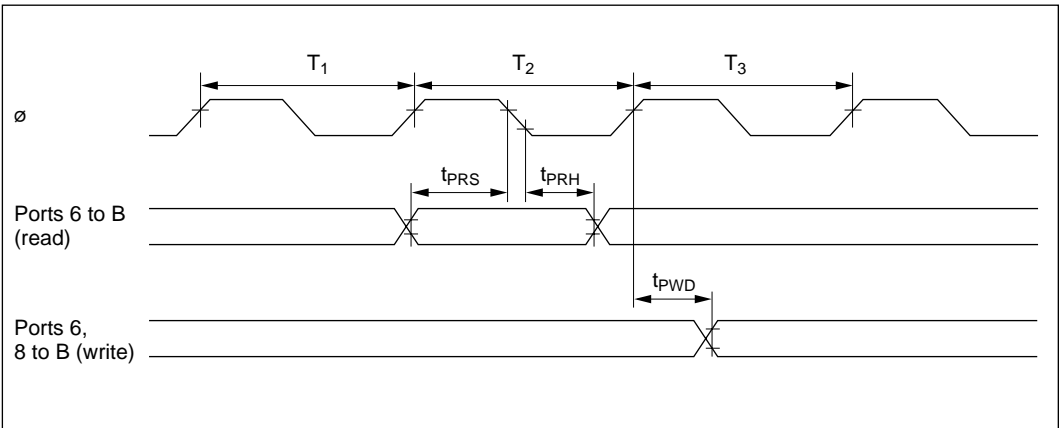

Figure 15-11 I/O Port Input/Output Timing

15.3.5 ITU Timing

ITU timing is shown as follows:

- ITU input/output timing

Figure 15-12 shows the ITU input/output timing.

- ITU external clock input timing

Figure 15-13 shows the ITU external clock input timing.

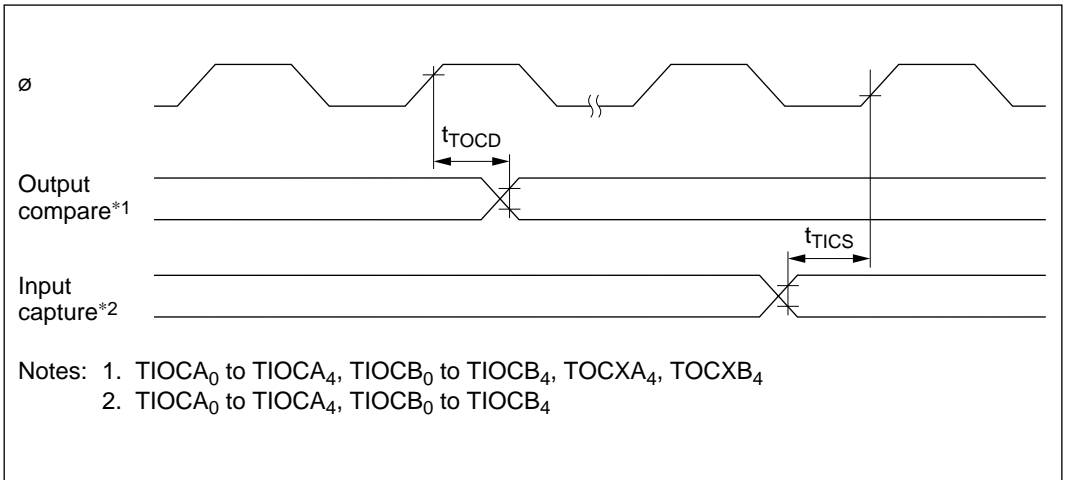

Figure 15-12 ITU Input/Output Timing

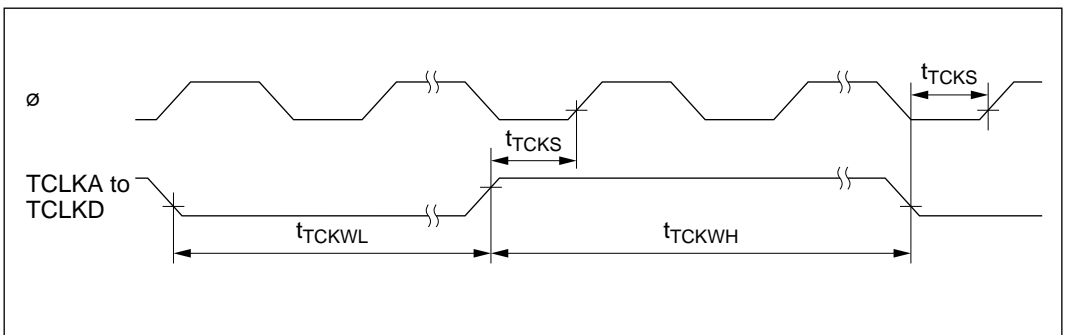

Figure 15-13 ITU Clock Input Timing

15.3.6 SCI Input/Output Timing

SCI timing is shown as follows:

- SCI input clock timing

Figure 15-14 shows the SCI input clock timing.

- SCI input/output timing (synchronous mode)

Figure 15-15 shows the SCI input/output timing in synchronous mode.

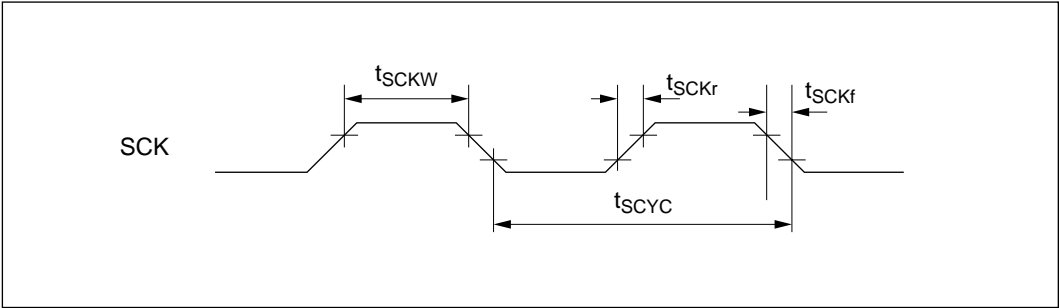

Figure 15-14 SCK Input Clock Timing

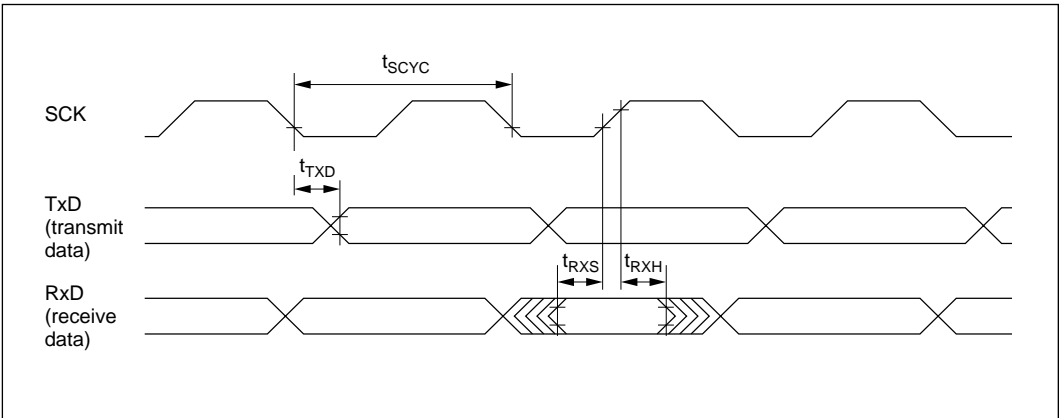

Figure 15-15 SCI Input/Output Timing in Synchronous Mode

Appendix A Instruction Set

A.1 Instruction List

Operand Notation

Symbol	Description
Rd	General destination register
Rs	General source register
Rn	General register
ERd	General destination register (address register or 32-bit register)
ERs	General source register (address register or 32-bit register)
ERn	General register (32-bit register)
(EAd)	Destination operand
(EAs)	Source operand
PC	Program counter
SP	Stack pointer
CCR	Condition code register
N	N (negative) flag in CCR
Z	Z (zero) flag in CCR
V	V (overflow) flag in CCR
C	C (carry) flag in CCR
disp	Displacement
→	Transfer from the operand on the left to the operand on the right, or transition from the state on the left to the state on the right
+	Addition of the operands on both sides
−	Subtraction of the operand on the right from the operand on the left
×	Multiplication of the operands on both sides
÷	Division of the operand on the left by the operand on the right
^	Logical AND of the operands on both sides
∨	Logical OR of the operands on both sides
⊕	Exclusive logical OR of the operands on both sides
¬	NOT (logical complement)
(), < >	Contents of operand

Note: General registers include 8-bit registers (R0H to R7H and R0L to R7L) and 16-bit registers (R0 to R7 and E0 to E7).

Condition Code Notation

Symbol	Description
↑↓	Changed according to execution result
*	Undetermined (no guaranteed value)
0	Cleared to 0
1	Set to 1
—	Not affected by execution of the instruction
Δ	Varies depending on conditions, described in notes

Table A-1 Instruction Set

1. Data transfer instructions

Mnemonic	Operand Size	Operation	Addressing Mode and Instruction Length (bytes)								Condition Code						No. of States *1		
			#xx	Rn	@ERn	@ (d, ERn)	@-ERn/@ERn+	@aa	@ (d, PC)	@@aa	Implied	I	H	N	Z	V	C	Normal	Advanced
MOV.B #xx:8, Rd	B	#xx:8 –Rd8	2									—	—	↓	↓	0	—	2	
MOV.B Rs, Rd	B	Rs8 –Rd8		2								—	—	↓	↓	0	—	2	
MOV.B @ERs, Rd	B	@ERs –Rd8			2							—	—	↓	↓	0	—	4	
MOV.B @(d:16, ERs), Rd	B	@(d:16, ERs) –Rd8				4						—	—	↓	↓	0	—	6	
MOV.B @(d:24, ERs), Rd	B	@(d:24, ERs) –Rd8					8					—	—	↓	↓	0	—	10	
MOV.B @ERs+, Rd	B	@ERs –Rd8 ERs32+1 –ERs32						2				—	—	↓	↓	0	—	6	
MOV.B @aa:8, Rd	B	@aa:8 –Rd8							2			—	—	↓	↓	0	—	4	
MOV.B @aa:16, Rd	B	@aa:16 –Rd8								4		—	—	↓	↓	0	—	6	
MOV.B @aa:24, Rd	B	@aa:24 –Rd8									6	—	—	↓	↓	0	—	8	
MOV.B Rs, @ERd	B	Rs8 –@ERd			2							—	—	↓	↓	0	—	4	
MOV.B Rs, @(d:16, ERd)	B	Rs8 –@(d:16, ERd)				4						—	—	↓	↓	0	—	6	
MOV.B Rs, @(d:24, ERd)	B	Rs8 –@(d:24, ERd)					8					—	—	↓	↓	0	—	10	
MOV.B Rs, @ERd	B	ERd32–1 –ERd32 Rs8 –@ERd						2				—	—	↓	↓	0	—	6	
MOV.B Rs, @aa:8	B	Rs8 –@aa:8							2			—	—	↓	↓	0	—	4	
MOV.B Rs, @aa:16	B	Rs8 –@aa:16								4		—	—	↓	↓	0	—	6	
MOV.B Rs, @aa:24	B	Rs8 –@aa:24									6	—	—	↓	↓	0	—	8	
MOV.W #xx:16, Rd	W	#xx:16 –Rd16	4									—	—	↓	↓	0	—	4	
MOV.W Rs, Rd	W	Rs16 –Rd16		2								—	—	↓	↓	0	—	2	
MOV.W @ERs, Rd	W	@ERs –Rd16			2							—	—	↓	↓	0	—	4	
MOV.W @(d:16, ERs), Rd	W	@(d:16, ERs) –Rd16				4						—	—	↓	↓	0	—	6	
MOV.W @(d:24, ERs), Rd	W	@(d:24, ERs) –Rd16					8					—	—	↓	↓	0	—	10	
MOV.W @ERs+, Rd	W	@ERs –Rd16 ERs32+2 –@ERd32						2				—	—	↓	↓	0	—	6	
MOV.W @aa:16, Rd	W	@aa:16 –Rd16							4			—	—	↓	↓	0	—	6	

Table A-1 Instruction Set (cont)

Mnemonic	Operand Size	Operation	Addressing Mode and Instruction Length (bytes)								Condition Code						No. of States ^{*1}		
			#xx	Rn	@ERn	@ (d, ERn)	@-ERn/@ERn+	@aa	@ (d, PC)	@@aa	Implied	I	H	N	Z	V	C	Normal	Advanced
MOV.W @aa:24, Rd	W	@aa:24 -Rd16						6										8	
MOV.W Rs, @ERd	W	Rs16 -@ERd			2													4	
MOV.W Rs, @(d:16, ERd)	W	Rs16 -@(d:16, ERd)				4												6	
MOV.W Rs, @(d:24, ERd)	W	Rs16 -@(d:24, ERd)					8											8	
MOV.W Rs, @-ERd	W	ERd32-2 -ERd32 Rs16 -@ERd						2										6	
MOV.W Rs, @aa:16	W	Rs16 -@aa:16						4										6	
MOV.W Rs, @aa:24	W	Rs16 -@aa:24						6										8	
MOVL #xx:32, Rd	L	#xx:32 -Rd32	6															8	
MOVL ERs, ERd	L	ERs32 -ERd32		2														2	
MOVL @ERs, ERd	L	@ERs -ERd32			4													8	
MOVL @(d:16, ERs), ERd	L	@(d:16, ERs) -ERd32				6												10	
MOVL @(d:24, ERs), ERd	L	@(d:24, ERs) -ERd32					10											14	
MOVL @ERs+, ERd	L	@ERs -ERd32 ERs32+4 -ERs32						4										10	
MOVL @aa:16, ERd	L	@aa:16 -ERd32						6										10	
MOVL @aa:24, ERd	L	@aa:24 -ERd32						8										12	
MOVL ERs, @ERd	L	ERs32 -@ERd			4													8	
MOVL ERs, @(d:16, ERd)	L	ERs32 -@(d:16, ERd)				6												10	
MOVL ERs, @(d:24, ERd)	L	ERs32 -@(d:24, ERd)					10											14	
MOVL ERs, @-ERd	L	ERd32-4 -ERd32 ERs32 -@ERd						4										10	
MOVL ERs, @aa:16	L	ERs32 -@aa:16						6										10	
MOVL ERs, @aa:24	L	ERs32 -@aa:24						8										12	
POP.W Rn	W	@SP -Rn16 SP+2 -SP							2									6	
POP.L ERn	L	@SP -ERn32 SP+4 -SP							4									8	

Table A-1 Instruction Set (cont)

Mnemonic	Operand Size	Operation	Addressing Mode and Instruction Length (bytes)								Condition Code						No. of States *1		
			#xx	Rn	@ERn	@ (d, ERn)	@ -ERn/@ERn+	@aa	@ (d, PC)	@ @aa	Implied	I	H	N	Z	V	C	Normal	Advanced
PUSH.W Rn	W	SP-2 -SP Rn16 -@SP								2	—	—	↑	↑	0	—	6		
PUSH.L ERn	L	SP-4 -SP ERn32 -@SP								4	—	—	↑	↑	0	—	8		
MOVFP @aa:16, Rd	B	Cannot be used in the H8/3004 and H8/3005							4		Cannot be used in the H8/3004 and H8/3005								
MOVTP R, @aa:16	B	Cannot be used in the H8/3004 and H8/3005							4		Cannot be used in the H8/3004 and H8/3005								

2. Arithmetic instructions

Mnemonic	Operand Size	Operation	Addressing Mode and Instruction Length (bytes)								Condition Code						No. of States *1		
			#xx	Rn	@ERn	@ (d, ERn)	@ -ERn/@ERn+	@aa	@ (d, PC)	@ @aa	Implied	I	H	N	Z	V	C	Normal	Advanced
ADD.B #xx:8, Rd	B	Rd8+#xx:8 -Rd8	2								—	↑	↑	↑	↑	↑	2		
ADD.B R, Rd	B	Rd8+Rs8 -Rd8		2							—	↑	↑	↑	↑	↑	2		
ADD.W #xx:16, Rd	W	Rd16+#xx:16 -Rd16	4								—	(1)	↑	↑	↑	↑	4		
ADD.W R, Rd	W	Rd16+Rs16 -Rd16		2							—	(1)	↑	↑	↑	↑	2		
ADD.L #xx:32, ERd	L	ERd32+#xx:32 → ERd32	6								—	(2)	↑	↑	↑	↑	6		
ADD.L ER, ERd	L	ERd32+ERs32 → ERd32		2							—	(2)	↑	↑	↑	↑	2		
ADDX.B #xx:8, Rd	B	Rd8+#xx:8 +C -Rd8	2								—	↑	↑	(3)	↑	↑	2		
ADDX.B R, Rd	B	Rd8+Rs8 +C -Rd8		2							—	↑	↑	(3)	↑	↑	2		
ADDS.L #1, ERd	L	ERd32+1 -ERd32		2							—	—	—	—	—	—	2		
ADDS.L #2, ERd	L	ERd32+2 -ERd32		2							—	—	—	—	—	—	2		
ADDS.L #4, ERd	L	ERd32+4 -ERd32		2							—	—	—	—	—	—	2		
INC.B Rd	B	Rd8+1 -Rd8		2							—	—	↑	↑	↑	—	2		
INC.W #1, Rd	W	Rd16+1 -Rd16		2							—	—	↑	↑	↑	—	2		
INC.W #2, Rd	W	Rd16+2 -Rd16		2							—	—	↑	↑	↑	—	2		

Table A-1 Instruction Set (cont)

Mnemonic	Operand Size	Operation	Addressing Mode and Instruction Length (bytes)								Condition Code						No. of States ^{*1}		
			#xx	Rn	@ERn	@ (d, ERn)	@ -ERn/@ERn+	@aa	@ (d, PC)	@@aa	Implied	I	H	N	Z	V	C	Normal	Advanced
INC.L #1, ERd	L	ERd32+1 –ERd32		2														2	
INC.L #2, ERd	L	ERd32+2 –ERd32		2														2	
DAA Rd	B	Rd8 decimal adjust –Rd8		2								*	↑	↑	*			2	
SUB.B Rs, Rd	B	Rd8–Rs8 –Rd8		2								↑	↑	↑	↑	↑		2	
SUB.W #xx:16, Rd	W	Rd16–#xx:16 –Rd16		4								(1)	↑	↑	↑	↑		4	
SUB.W Rs, Rd	W	Rd16–Rs16 –Rd16		2								(1)	↑	↑	↑	↑		2	
SUB.L #xx:32, ERd	L	ERd32–#xx:32 –ERd32		6								(2)	↑	↑	↑	↑		6	
SUB.L ERs, ERd	L	ERd32–ERs32 –ERd32		2								(2)	↑	↑	↑	↑		2	
SUBX.B #xx:8, Rd	B	Rd8–#xx:8–C –Rd8		2								↑	↑	(3)	↑	↑		2	
SUBX.B Rs, Rd	B	Rd8–Rs8–C –Rd8		2								↑	↑	(3)	↑	↑		2	
SUBS.L #1, ERd	L	ERd32–1 –ERd32		2														2	
SUBS.L #2, ERd	L	ERd32–2 –ERd32		2														2	
SUBS.L #4, ERd	L	ERd32–4 –ERd32		2														2	
DEC.B Rd	B	Rd8–1 –Rd8		2									↑	↑	↑			2	
DEC.W #1, Rd	W	Rd16–1 –Rd16		2									↑	↑	↑			2	
DEC.W #2, Rd	W	Rd16–2 –Rd16		2									↑	↑	↑			2	
DEC.L #1, ERd	L	ERd32–1 –ERd32		2									↑	↑	↑			2	
DEC.L #2, ERd	L	ERd32–2 –ERd32		2									↑	↑	↑			2	
DAS.Rd	B	Rd8 decimal adjust –Rd8		2									*	↑	↑	*		2	
MULXU. B Rs, Rd	B	Rd8 ×Rs8 –Rd16 (unsigned multiplication)		2														14	
MULXU. W Rs, ERd	W	Rd16 ×Rs16 –ERd32 (unsigned multiplication)		2														22	
MULXS. B Rs, Rd	B	Rd8 ×Rs8 –Rd16 (signed multiplication)		4									↑	↑				16	
MULXS. W Rs, ERd	W	Rd16 ×Rs16 –ERd32 (signed multiplication)		4									↑	↑				24	
DIVXU. B Rs, Rd	B	Rd16 ÷ Rs8 –Rd16 (RdH: remainder, RdL: quotient) (unsigned division)		2									(6)	(7)				14	

Table A-1 Instruction Set (cont)

Mnemonic	Operand Size	Operation	Addressing Mode and Instruction Length (bytes)								Condition Code						No. of States *1		
			#xx	Rn	@ERn	@ (d, ERn)	@ -ERn/@ERn+	@aa	@ (d, PC)	@ @aa	Implied	I	H	N	Z	V	C	Normal	Advanced
DIVXU. W Rs, ERd	W	ERd32 ÷ Rs16 → ERd32 (Ed: remainder, Rd: quotient) (unsigned division)	2								—	—	(6)	(7)	—	—	22		
DIVXS. B Rs, Rd	B	Rd16 ÷ Rs8 → Rd16 (RdH: remainder, RdL: quotient) (signed division)	4								—	—	(8)	(7)	—	—	16		
DIVXS. W Rs, ERd	W	ERd32 ÷ Rs16 → ERd32 (Ed: remainder, Rd: quotient) (signed division)	4								—	—	(8)	(7)	—	—	24		
CMP.B #xx:8, Rd	B	Rd8 - #xx:8	2								—	↑	↑	↑	↑	↑	2		
CMP.B Rs, Rd	B	Rd8 - Rs8	2								—	↑	↑	↑	↑	↑	2		
CMP.W #xx:16, Rd	W	Rd16 - #xx:16	4								—	(1)	↑	↑	↑	↑	4		
CMP.W Rs, Rd	W	Rd16 - Rs16	2								—	(1)	↑	↑	↑	↑	2		
CMP.L #xx:32, ERd	L	ERd32 - #xx:32	6								—	(2)	↑	↑	↑	↑	4		
CMP.L ERs, ERd	L	ERd32 - ERs32	2								—	(2)	↑	↑	↑	↑	2		
NEG.B Rd	B	0 - Rd8 → Rd8	2								—	↑	↑	↑	↑	↑	2		
NEG.W Rd	W	0 - Rd16 → Rd16	2								—	↑	↑	↑	↑	↑	2		
NEG.L ERd	L	0 - ERd32 → ERd32	2								—	↑	↑	↑	↑	↑	2		
EXTU.W Rd	W	0 ← (<bits 15 to 8> of Rd16)	2								—	—	0	↑	0	—	2		
EXTU.L ERd	L	0 ← (<bits 31 to 16> of ERd32)	2								—	—	0	↑	0	—	2		
EXTS.W Rd	W	(<bit 7> of Rd16) → (<bits 15 to 8> of Rd16)	2								—	—	↑	↑	0	—	2		
EXTS.L ERd	L	(<bit 15> of ERd32) → (<bits 31 to 16> of ERd32)	2								—	—	↑	↑	0	—	2		

Table A-1 Instruction Set (cont)

3. Logic instructions

Mnemonic	Operand Size	Operation	Addressing Mode and Instruction Length (bytes)								Condition Code						No. of States ^{*1}		
			#xx	Rn	@ERn	@ (d, ERn)	@-ERn/@ERn+	@aa	@ (d, PC)	@@aa	Implied	I	H	N	Z	V	C	Normal	Advanced
AND.B #xx:8, Rd	B	Rd8#xx:8 –Rd8	2										—	—	↑	↓	0	—	2
AND.B Rs, Rd	B	Rd8Rs8 –Rd8		2									—	—	↑	↓	0	—	2
AND.W #xx:16, Rd	W	Rd16#xx:16 –Rd16	4										—	—	↑	↓	0	—	4
AND.W Rs, Rd	W	Rd16Rs16 –Rd16		2									—	—	↑	↓	0	—	2
AND.L #xx:32, ERd	L	ERd32#xx:32 –ERd32	6										—	—	↑	↓	0	—	6
AND.L ERs, ERd	L	ERd32ERs32 –ERd32		4									—	—	↑	↓	0	—	4
OR.B #xx:8, Rd	B	Rd8#xx:8 –Rd8	2										—	—	↑	↓	0	—	2
OR.B Rs, Rd	B	Rd8Rs8 –Rd8		2									—	—	↑	↓	0	—	2
OR.W #xx:16, Rd	W	Rd16#xx:16 –Rd16	4										—	—	↑	↓	0	—	4
OR.W Rs, Rd	W	Rd16Rs16 –Rd16		2									—	—	↑	↓	0	—	2
OR.L #xx:32, ERd	L	ERd32#xx:32 –ERd32	6										—	—	↑	↓	0	—	6
OR.L ERs, ERd	L	ERd32ERs32 –ERd32		4									—	—	↑	↓	0	—	4
XOR.B #xx:8, Rd	B	Rd8#xx:8 –Rd8	2										—	—	↑	↓	0	—	2
XOR.B Rs, Rd	B	Rd8Rs8 –Rd8		2									—	—	↑	↓	0	—	2
XOR.W #xx:16, Rd	W	Rd16#xx:16 –Rd16	4										—	—	↑	↓	0	—	4
XOR.W Rs, Rd	W	Rd16Rs16 –Rd16		2									—	—	↑	↓	0	—	2
XOR.L #xx:32, ERd	L	ERd32#xx:32 –ERd32	6										—	—	↑	↓	0	—	6
XOR.L ERs, ERd	L	ERd32ERs32 –ERd32		4									—	—	↑	↓	0	—	4
NOT.B Rd	B	¬ Rd8 –Rd8		2									—	—	↑	↓	0	—	2
NOT.W Rd	W	¬ Rd16 –Rd16		2									—	—	↑	↓	0	—	2
NOT.L ERd	L	¬ Rd32 –Rd32		2									—	—	↑	↓	0	—	2

Table A-1 Instruction Set (cont)

4. Shift instructions









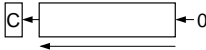
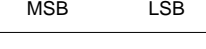

Mnemonic	Operand Size	Operation	Addressing Mode and Instruction Length (bytes)								Condition Code						No. of States *1		
			#xx	Rn	@ERn	@ (d, ERn)	@-ERn/@ERn+	@aa	@ (d, PC)	@aa	Implied	I	H	N	Z	V	C	Normal	Advanced
SHAL.B Rd	B		2								—	—	↑	↑	↑	↑	2		
SHAL.W Rd	W		2								—	—	↑	↑	↑	↑	2		
SHAL.L ERd	L	MSB ← LSB	2								—	—	↑	↑	↑	↑	2		
SHAR.B Rd	B		2								—	—	↑	↑	0	↑	2		
SHAR.W Rd	W		2								—	—	↑	↑	0	↑	2		
SHAR.L ERd	L	MSB → LSB	2								—	—	↑	↑	0	↑	2		
SHLL.B Rd	B		2								—	—	↑	↑	0	↑	2		
SHLL.W Rd	W		2								—	—	↑	↑	0	↑	2		
SHLL.L ERd	L	MSB ← LSB	2								—	—	↑	↑	0	↑	2		
SHLR.B Rd	B		2								—	—	↑	↑	0	↑	2		
SHLR.W Rd	W		2								—	—	↑	↑	0	↑	2		
SHLR.L ERd	L	MSB → LSB	2								—	—	↑	↑	0	↑	2		
ROTXL.B Rd	B		2								—	—	↑	↑	0	↑	2		
ROTXL.W Rd	W		2								—	—	↑	↑	0	↑	2		
ROTXL.L ERd	L	MSB ← LSB	2								—	—	↑	↑	0	↑	2		
ROTXR.B Rd	B		2								—	—	↑	↑	0	↑	2		
ROTXR.W Rd	W		2								—	—	↑	↑	0	↑	2		
ROTXR.L ERd	L	MSB → LSB	2								—	—	↑	↑	0	↑	2		
ROTL.B Rd	B		2								—	—	↑	↑	0	↑	2		
ROTL.W Rd	W		2								—	—	↑	↑	0	↑	2		
ROTL.L ERd	L	MSB ← LSB	2								—	—	↑	↑	0	↑	2		
ROTR.B Rd	B		2								—	—	↑	↑	0	↑	2		
ROTR.W Rd	W		2								—	—	↑	↑	0	↑	2		
ROTR.L ERd	L	MSB → LSB	2								—	—	↑	↑	0	↑	2		

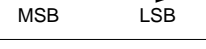
Table A-1 Instruction Set (cont)

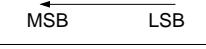
5. Bit manipulation instructions

Mnemonic	Operand Size	Operation	Addressing Mode and Instruction Length (bytes)								Condition Code						No. of States ^{*1}		
			#xx	Rn	@ERn	@ (d, ERn)	@-ERn/@ERn+	@aa	@ (d, PC)	@@aa	Implied	I	H	N	Z	V	C	Normal	Advanced
BSET #xx:3, Rd	B	(#xx:3 of Rd8) ←1		2														2	
BSET #xx:3, @ERd	B	(#xx:3 of @ERd) ←1			4													8	
BSET #xx:3, @aa:8	B	(#xx:3 of @aa:8) ←1						4										8	
BSET Rn, Rd	B	(Rn8 of Rd8) ←1		2														2	
BSET Rn, @ERd	B	(Rn8 of @ERd) ←1			4													8	
BSET Rn, @aa:8	B	(Rn8 of @aa:8) ←1						4										8	
BCLR #xx:3, Rd	B	(#xx:3 of Rd8) ←0		2														2	
BCLR #xx:3, @ERd	B	(#xx:3 of @ERd) ←0			4													8	
BCLR #xx:3, @aa:8	B	(#xx:3 of @aa:8) ←0						4										8	
BCLR Rn, Rd	B	(Rn8 of Rd8) ←0		2														2	
BCLR Rn, @ERd	B	(Rn8 of @ERd) ←0			4													8	
BCLR Rn, @aa:8	B	(Rn8 of @aa:8) ←0						4										8	
BNOT #xx:3, Rd	B	(#xx:3 of Rd8) ← ¬(#xx:3 of Rd8)		2														2	
BNOT #xx:3, @ERd	B	(#xx:3 of @ERd) ← ¬(#xx:3 of @ERd)			4													8	
BNOT #xx:3, @aa:8	B	(#xx:3 of @aa:8) ← ¬(#xx:3 of @aa:8)						4										8	
BNOT Rn, Rd	B	(Rn8 of Rd8) ← ¬(Rn8 of Rd8)		2														2	
BNOT Rn, @ERd	B	(Rn8 of @ERd) ← ¬(Rn8 of @ERd)			4													8	
BNOT Rn, @aa:8	B	(Rn8 of @aa:8) ← ¬(Rn8 of @aa:8)						4										8	
BTST #xx:3, Rd	B	¬(#xx:3 of Rd8) –Z		2										↑				2	
BTST #xx:3, @ERd	B	¬(#xx:3 of @ERd) –Z			4									↑				6	
BTST #xx:3, @aa:8	B	¬(#xx:3 of @aa:8) –Z						4						↑				6	
BTST Rn, Rd	B	¬(Rn8 of @Rd8) –Z		2										↑				2	
BTST Rn, @ERd	B	¬(Rn8 of @ERd) –Z			4									↑				6	
BTST Rn, @aa:8	B	¬(Rn8 of @aa:8) –Z						4						↑				6	
BLD #xx:3, Rd	B	(#xx:3 of Rd8) –C		2													↑	2	

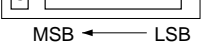
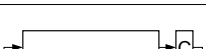
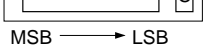
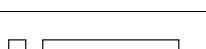
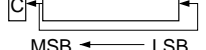
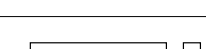
Table A-1 Instruction Set (cont)

Mnemonic	Operand Size	Operation	Addressing Mode and Instruction Length (bytes)								Condition Code						No. of States *1		
			#xx	Rn	@ERn	@ (d, ERn)	@ -ERn/@ERn+	@aa	@ (d, PC)	@ @aa	Implied	I	H	N	Z	V	C	Normal	Advanced
BLD #xx:3, @ERd	B	(#xx:3 of @ERd) –€			4										↑		6		
BLD #xx:3, @aa:8	B	(#xx:3 of @aa:8) –€					4								↑		6		
BILD #xx:3, Rd	B	¬ (#xx:3 of Rd8) –€		2											↑		2		
BILD #xx:3, @ERd	B	¬ (#xx:3 of @ERd) –€			4										↑		6		
BILD #xx:3, @aa:8	B	¬ (#xx:3 of @aa:8) –€					4								↑		6		
BST #xx:3, Rd	B	C ¬ (#xx:3 of Rd8)		2													2		
BST #xx:3, @ERd	B	C ¬ (#xx:3 of @ERd24)			4												8		
BST #xx:3, @aa:8	B	C ¬ (#xx:3 of @aa:8)					4										8		
BIST #xx:3, Rd	B	¬ C ¬ (#xx:3 of Rd8)		2													2		
BIST #xx:3, @ERd	B	¬ C ¬ (#xx:3 of @ERd24)			4												8		
BIST #xx:3, @aa:8	B	¬ C ¬ (#xx:3 of @aa:8)					4										8		
BAND #xx:3, Rd	B	C (#xx:3 of Rd8) –€		2											↑		2		
BAND #xx:3, @ERd	B	C (#xx:3 of @ERd24) –€			4										↑		6		
BAND #xx:3, @aa:8	B	C (#xx:3 of @aa:8) –€					4								↑		6		
BIAND #xx:3, Rd	B	C ¬ (#xx:3 of Rd8) –€		2											↑		2		
BIAND #xx:3, @ERd	B	C ¬ (#xx:3 of @ERd24) –€			4										↑		6		
BIAND #xx:3, @aa:8	B	C ¬ (#xx:3 of @aa:8) –€					4								↑		6		
BOR #xx:3, Rd	B	C (#xx:3 of Rd8) –€		2											↑		2		
BOR #xx:3, @ERd	B	C (#xx:3 of @ERd24) –€			4										↑		6		
BOR #xx:3, @aa:8	B	C (#xx:3 of @aa:8) –€					4								↑		6		
BIOR #xx:3, Rd	B	C ¬ (#xx:3 of Rd8) –€		2											↑		2		
BIOR #xx:3, @ERd	B	C ¬ (#xx:3 of @ERd24) –€			4										↑		6		
BIOR #xx:3, @aa:8	B	C ¬ (#xx:3 of @aa:8) –€					4								↑		6		
BXOR #xx:3, Rd	B	C ⊕ (#xx:3 of Rd8) –€		2											↑		2		
BXOR #xx:3, @ERd	B	C ⊕ (#xx:3 of @ERd24) –€			4										↑		6		
BXOR #xx:3, @aa:8	B	C ⊕ (#xx:3 of @aa:8) –€					4								↑		6		
BIXOR #xx:3, Rd	B	C ⊕¬ (#xx:3 of Rd8) –€		2											↑		2		
BIXOR #xx:3, @ERd	B	C ⊕¬ (#xx:3 of @ERd24) –€			4										↑		6		
BIXOR #xx:3, @aa:8	B	C ⊕¬ (#xx:3 of @aa:8) –€					4								↑		6		

Table A-1 Instruction Set (cont)

6. Branching instructions

Mnemonic	Operand Size	Operation	Addressing Mode and Instruction Length (bytes)								Condition Code						No. of States ^{*1}		
			#xx	Rn	@ERn	@ (d, ERn)	@ -ERn/@ERn+	@aa	@ (d, PC)	@@aa	Implied	I	H	N	Z	V	C	Normal	Advanced
BRA d:8 (BT d:8)	—	If condition is true then PC ←PC+d else next;	Always															4	
BRA d:16 (BT d:16)	—																		6
BRN d:8 (BF d:8)	—	Never																4	
BRN d:16 (BF d:16)	—																		6
BHI d:8	—	C √Z = 0																4	
BHI d:16	—																		6
BLS d:8	—	C √Z = 1																4	
BLS d:16	—																		6
BCC d:8 (BHS d:8)	—	C = 0																4	
BCC d:16 (BHS d:16)	—																		6
BCS d:8 (BLO d:8)	—	C = 1																4	
BCS d:16 (BLO d:16)	—																		6
BNE d:8	—	Z = 0																4	
BNE d:16	—																		6
BEQ d:8	—	Z = 1																4	
BEQ d:16	—																		6
BVC d:8	—	V = 0																4	
BVC d:16	—																		6
BVS d:8	—	V = 1																4	
BVS d:16	—																		6
BPL d:8	—	N = 0																4	
BPL d:16	—																		6
BMI d:8	—	N = 1																4	
BMI d:16	—																		6
BGE d:8	—	N ⊕ V = 0																4	
BGE d:16	—																		6
BLT d:8	—	N ⊕ V = 1																4	
BLT d:16	—																		6
BGT d:8	—	Z √(N ⊕ V) = 0																4	
BGT d:16	—																		6

Table A-1 Instruction Set (cont)

Mnemonic	Operand Size	Operation	Addressing Mode and Instruction Length (bytes)								Condition Code						No. of States *1		
			#xx	Rn	@ERn	@ (d, ERn)	@ -ERn/@ERn+	@aa	@ (d, PC)	@ @aa	Implied	I	H	N	Z	V	C	Normal	Advanced
BLE d:8	—	If condition is true then PC ←PC+d else next; $Z \vee (N \oplus V) = 1$							2									4	
BLE d:16	—								4									6	
JMP @ERn	—	PC ←ERn			2													4	
JMP @aa:24	—	PC ←aa:24						4									6		
JMP @@aa:8	—	PC ←@aa:8							2						8	10			
BSR d:8	—	PC ←@-SP PC ←PC+d:8							2						6	8			
BSR d:16	—	PC ←@-SP PC ←PC+d:16							4						8	10			
JSR @ERn	—	PC ←@-SP PC ←@ERn			2										6	8			
JSR @aa:24	—	PC ←@-SP PC ←@aa:24							4						8	10			
JSR @@aa:8	—	PC ←@-SP PC ←@aa:8								2					8	12			
RTS	—	PC ←@SP+								2					8	10			

Table A-1 Instruction Set (cont)

7. System control instructions

Mnemonic	Operand Size	Operation	Addressing Mode and Instruction Length (bytes)								Condition Code						No. of States ^{*1}		
			#xx	Rn	@ERn	@ (d, ERn)	@-ERn/@ERn+	@aa	@ (d, PC)	@@aa	Implied	I	H	N	Z	V	C	Normal	Advanced
TRAPA #x:2	—	PC ←@-SP CCR ←@-SP <vector> ←PC																14	16
RTE	—	CCR ←@SP+ PC ←@SP+									↑	↑	↑	↑	↑	↑			10
SLEEP	—	Transition to power-down state									—	—	—	—	—	—			2
LDC #xx:8, CCR	B	#xx:8 ←CCR	2								↑	↑	↑	↑	↑	↑			2
LDC Rs, CCR	B	Rs8 ←CCR		2							↑	↑	↑	↑	↑	↑			2
LDC @ERs, CCR	W	@ERs ←CCR			4						↑	↑	↑	↑	↑	↑			6
LDC @(d:16, ERs), CCR	W	@(d:16, ERs) ←CCR				6					↑	↑	↑	↑	↑	↑			8
LDC @(d:24, ERs), CCR	W	@(d:24, ERs) ←CCR					10				↑	↑	↑	↑	↑	↑			12
LDC @ERs+, CCR	W	@ERs ←CCR ERs32+2 ←ERs32					4				↑	↑	↑	↑	↑	↑			8
LDC @aa:16, CCR	W	@aa:16 ←CCR						6			↑	↑	↑	↑	↑	↑			8
LDC @aa:24, CCR	W	@aa:24 ←CCR							8		↑	↑	↑	↑	↑	↑			10
STC CCR, Rd	B	CCR ←Rd8		2							—	—	—	—	—	—			2
STC CCR, @ERd	W	CCR ←@ERd			4						—	—	—	—	—	—			6
STC CCR, @(d:16, ERd)	W	CCR ←@(d:16, ERd)				6					—	—	—	—	—	—			8
STC CCR, @(d:24, ERd)	W	CCR ←@(d:24, ERd)					10				—	—	—	—	—	—			12
STC CCR, @-ERd	W	ERd32-2 ←ERd32 CCR ←@ERd						4			—	—	—	—	—	—			8
STC CCR, @aa:16	W	CCR ←@aa:16							6		—	—	—	—	—	—			8
STC CCR, @aa:24	W	CCR ←@aa:24								8	—	—	—	—	—	—			10
ANDC #xx:8, CCR	B	CCR#xx:8 ←CCR	2								↑	↑	↑	↑	↑	↑			2
ORC #xx:8, CCR	B	CCR#xx:8 ←CCR	2								↑	↑	↑	↑	↑	↑			2
XORC #xx:8, CCR	B	CCR#xx:8 ←CCR	2								↑	↑	↑	↑	↑	↑			2
NOP	—	PC ←PC+2								2	—	—	—	—	—	—			2

Table A-1 Instruction Set (cont)

8. Block transfer instructions

Mnemonic	Operand Size	Operation	Addressing Mode and Instruction Length (bytes)							Implied	Condition Code					No. of States *1			
			#xx	Rn	@ERn	@ (d, ERn)	@-ERn/@ERn+	@aa	@ (d, PC)		@aa	I	H	N	Z	V	C	Normal	Advanced
EEPMOV. B	—	if R4L ≠ 0 then repeat @R5 –@R6 R5+1 –R5 R6+1 –R6 R4L–1 –R4L until R4L=0 else next								4	—	—	—	—	—	—	8+4n*2		
EEPMOV. W	—	if R4 ≠ 0 then repeat @R5 –@R6 R5+1 –R5 R6+1 –R6 R4L–1 –R4 until R4=0 else next								4	—	—	—	—	—	—	8+4n*2		

Notes: 1. The number of states is the number of states required for execution when the instruction and its operands are located in on-chip memory. For other cases see section A.3, Number of States Required for Execution.

2. n is the value set in register R4L or R4.

- (1) Set to 1 when a carry or borrow occurs at bit 11; otherwise cleared to 0.
- (2) Set to 1 when a carry or borrow occurs at bit 27; otherwise cleared to 0.
- (3) Retains its previous value when the result is zero; otherwise cleared to 0.
- (4) Set to 1 when the adjustment produces a carry; otherwise retains its previous value.
- (5) The number of states required for execution of an instruction that transfers data in synchronization with the E clock is variable.
- (6) Set to 1 when the divisor is negative; otherwise cleared to 0.
- (7) Set to 1 when the divisor is zero; otherwise cleared to 0.
- (8) Set to 1 when the quotient is negative; otherwise cleared to 0.

A.2 Operation Code Maps

Table A-2 Operation Code Map (1)

Instruction code:

1st byte		2nd byte	
AH	AL	BH	BL

Instruction when most significant bit of BH is 0.



Instruction when most significant bit of BH is 1.

AL	0	1	2	3	4	5	6	7	8	9	A	B	C	D	E	F	
AH	0	Table A.2 (2)	STC	LDC	ORG	XORC	ANDC	LDC	ADD	Table A.2 (2)	Table A.2 (2)	Table A.2 (2)	Table A.2 (2)	Table A.2 (2)	Table A.2 (2)	Table A.2 (2)	
	1	Table A.2 (2)	Table A.2 (2)	Table A.2 (2)	OR.B	XOR.B	AND.B	Table A.2 (2)	SUB	Table A.2 (2)	Table A.2 (2)	Table A.2 (2)	CMP	SUBX	Table A.2 (2)	Table A.2 (2)	
	2	MOV.B															
	3	MOV															
	4	BRA	BRN	BHI	BLS	BCC	BCS	BNE	BEQ	BVC	BVS	BPL	BMI	BGE	BLT	BGT	BLE
	5	MULXU	DIVXU	MULXU	DIVXU	RTS	BSR	RTE	TRAPA	Table A.2 (2)	JMP	BSR	JSR				
	6	BSET	BNOT	BCLR	BTST	BIOR	BXOR	AND	BST	MOV							Table A.2 (3)
	7					BOR	BAND	BAND	BLD	MOV	Table A.2 (2)	Table A.2 (2)	EEMOV				
	8	ADD															
	9	ADDX															
	A	CMP															
	B	SUBX															
	C	OR															
	D	XOR															
	E	AND															
	F	MOV															

Table A-2 Operation Code Map (2)

Instruction code:

1st byte		2nd byte	
AH	AL	BH	BL

BH/AH	0	1	2	3	4	5	6	7	8	9	A	B	C	D	E	F
01	MOV				LDC/STC				SLEEP				Table A.2 (3)	Table A.2 (3)		Table A.2 (3)
0A	INC	ADD														
0B	ADDS					INC		INC	ADDS					INC		INC
0F	DAA	MOV														
10	SHLL								SHAL			SHAL				
11	SHLR								SHAR			SHAR				
12	ROTXL								ROTL			ROTL				
13	ROTXR								ROTR			ROTR				
17	NOT								EXTU			NEG		EXTS		EXTS
1A	DEC	SUB														
1B	SUBS								DEC			SUB		DEC		DEC
1F	DAS	CMP														
58	BRA	BRN	BHI	BLS	BCC	BCS	BNE	BEQ	BVC	BVS	BPL	BMI	BGE	BLT	BGT	BLE
79	MOV	ADD	CMP	SUB	OR	XOR	AND									
7A	MOV	ADD	CMP	SUB	OR	XOR	AND									

Table A-2 Operation Code Map (3)

1st byte		2nd byte		3rd byte		4th byte	
AH	AL	BH	BL	CH	CL	DH	DL

Instruction code:

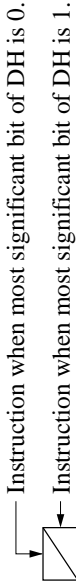

C	0	1	2	3	4	5	6	7	8	9	A	B	C	D	E	F
AH ALBH BLCH										LDC		LDC		LDC		LDC
01406										LDC		LDC		LDC		LDC
01C05	MULXS		MULXS													
01D05		DIVXS		DIVXS												
01F06					OR	XOR	AND									
7C106*1				BTST												
7C107*1				BTST	BOR	BXOR	BAND	BID								
					BIOR	BIXOR	BIAND	BILD								
7D106*1	BSET	BNOT		BCLR				BST								
7D107*1	BSET	BNOT		BCLR				BIST								
7Eaa6*2				BTST												
7Eaa7*2				BTST	BOR	BXOR	BAND	BLD								
					BIOR	BIXOR	BIAND	BILD								
7Faa6*2	BSET	BNOT		BCLR				BST								
7Faa7*2	BSET	BNOT		BCLR				BIST								

Notes: 1. r is the register designation field.
 2. aa is the absolute address field.

A.3 Number of States Required for Execution

The tables in this section can be used to calculate the number of states required for instruction execution by the H8/300H CPU. Table A-3 indicates the number of instruction fetch, data read/write, and other cycles occurring in each instruction. Table A-3 indicates the number of states required per cycle according to the bus size. The number of states required for execution of an instruction can be calculated from these two tables as follows:

$$\text{Number of states} = I \times S_I + J \times S_J + K \times S_K + L \times S_L + M \times S_M + N \times S_N$$

Examples of Calculation of Number of States Required for Execution

Examples: Advanced mode, stack located in external address space, on-chip supporting modules accessed with 8-bit bus width, external devices accessed in three states with one wait state and 16-bit bus width.

BSET #0, @FFFFFFC7:8

From table A-4, $I = L = 2$ and $J = K = M = N = 0$

From table A-3, $S_I = 4$ and $S_L = 3$

Number of states = $2 \times 4 + 2 \times 3 = 14$

JSR @@30

From table A-3, $I = J = K = 2$ and $L = M = N = 0$

From table A-3, $S_I = S_J = S_K = 4$

Number of states = $2 \times 4 + 2 \times 4 + 2 \times 4 = 24$

Table A-3 Number of States per Cycle

		Access Conditions						
		On-Chip Memory	On-Chip Supporting Module		External Device			
			8-Bit Bus	16-Bit Bus	8-Bit Bus		16-Bit Bus	
Cycle				2-State Access	3-State Access	2-State Access	3-State Access	
Instruction fetch	S_I	2	6	3	4	$6 + 2m$	2	$3 + m$
Branch address read	S_J							
Stack operation	S_K							
Byte data access	S_L		3		2	$3 + m$		
Word data access	S_M		6		4	$6 + 2m$		
Internal operation	S_N	1						

Legend

m: Number of wait states inserted into external device access

Table A-4 Number of Cycles per Instruction

Instruction	Mnemonic	Instruction	Branch	Stack	Byte Data	Word Data	Internal
		Fetch	Addr. Read	Operation	Access	Access	Operation
		I	J	K	L	M	N
ADD	ADD.B #xx:8, Rd	1					
	ADD.B Rs, Rd	1					
	ADD.W #xx:16, Rd	2					
	ADD.W Rs, Rd	1					
	ADD.L #xx:32, ERd	3					
	ADD.L ERs, ERd	1					
ADDS	ADDS #1/2/4, ERd	1					
ADDX	ADDX #xx:8, Rd	1					
	ADDX Rs, Rd	1					
AND	AND.B #xx:8, Rd	1					
	AND.B Rs, Rd	1					
	AND.W #xx:16, Rd	2					
	AND.W Rs, Rd	1					
	AND.L #xx:32, ERd	3					
	AND.L ERs, ERd	2					
ANDC	ANDC #xx:8, CCR	1					
BAND	BAND #xx:3, Rd	1					
	BAND #xx:3, @ERd	2			1		
	BAND #xx:3, @aa:8	2			1		
Bcc	BRA d:8 (BT d:8)	2					
	BRN d:8 (BF d:8)	2					
	BHI d:8	2					
	BLS d:8	2					
	BCC d:8 (BHS d:8)	2					
	BCS d:8 (BLO d:8)	2					
	BNE d:8	2					
	BEQ d:8	2					
	BVC d:8	2					
	BVS d:8	2					
	BPL d:8	2					
	BMI d:8	2					
	BGE d:8	2					
	BLT d:8	2					
	BGT d:8	2					
BLE d:8	2						

Table A-4 Number of Cycles per Instruction (cont)

Instruction	Mnemonic	Instruction	Branch	Stack	Byte Data	Word Data	Internal
		Fetch	Addr. Read	Operation	Access	Access	Operation
		I	J	K	L	M	N
Bcc	BRA d:16 (BT d:16)	2					2
	BRN d:16 (BF d:16)	2					2
	BHI d:16	2					2
	BLS d:16	2					2
	BCC d:16 (BHS d:16)	2					2
	BCS d:16 (BLO d:16)	2					2
	BNE d:16	2					2
	BEQ d:16	2					2
	BVC d:16	2					2
	BVS d:16	2					2
	BPL d:16	2					2
	BMI d:16	2					2
	BGE d:16	2					2
	BLT d:16	2					2
	BGT d:16	2					2
BLE d:16	2					2	
BCLR	BCLR #xx:3, Rd	1					
	BCLR #xx:3, @ERd	2			2		
	BCLR #xx:3, @aa:8	2			2		
	BCLR Rn, Rd	1					
	BCLR Rn, @ERd	2			2		
	BCLR Rn, @aa:8	2			2		
BIAND	BIAND #xx:3, Rd	1					
	BIAND #xx:3, @ERd	2			1		
	BIAND #xx:3, @aa:8	2			1		
BILD	BILD #xx:3, Rd	1					
	BILD #xx:3, @ERd	2			1		
	BILD #xx:3, @aa:8	2			1		
BIOR	BIOR #xx:8, Rd	1					
	BIOR #xx:8, @ERd	2			1		
	BIOR #xx:8, @aa:8	2			1		
BIST	BIST #xx:3, Rd	1					
	BIST #xx:3, @ERd	2			2		
	BIST #xx:3, @aa:8	2			2		
BIXOR	BIXOR #xx:3, Rd	1					
	BIXOR #xx:3, @ERd	2			1		
	BIXOR #xx:3, @aa:8	2			1		
BLD	BLD #xx:3, Rd	1					
	BLD #xx:3, @ERd	2			1		
	BLD #xx:3, @aa:8	2			1		

Table A-4 Number of Cycles per Instruction (cont)

Instruction	Mnemonic	Instruction		Branch	Stack	Byte Data	Word Data	Internal
		Fetch	Addr. Read	Read	Operation	Access	Access	Operation
		I	J	K	L	M	N	
BNOT	BNOT #xx:3, Rd	1						
	BNOT #xx:3, @ERd	2				2		
	BNOT #xx:3, @aa:8	2				2		
	BNOT Rn, Rd	1						
	BNOT Rn, @ERd	2				2		
	BNOT Rn, @aa:8	2				2		
BOR	BOR #xx:3, Rd	1						
	BOR #xx:3, @ERd	2				1		
	BOR #xx:3, @aa:8	2				1		
BSET	BSET #xx:3, Rd	1						
	BSET #xx:3, @ERd	2				2		
	BSET #xx:3, @aa:8	2				2		
	BSET Rn, Rd	1						
	BSET Rn, @ERd	2				2		
	BSET Rn, @aa:8	2				2		
BSR	BSR d:8	Normal	2		1			
		Advanced	2		2			
	BSR d:16	Normal	2		1			2
		Advanced	2		2			2
BST	BST #xx:3, Rd	1						
	BST #xx:3, @ERd	2				2		
	BST #xx:3, @aa:8	2				2		
BTST	BTST #xx:3, Rd	1						
	BTST #xx:3, @ERd	2				1		
	BTST #xx:3, @aa:8	2				1		
	BTST Rn, Rd	1						
	BTST Rn, @ERd	2				1		
	BTST Rn, @aa:8	2				1		
BXOR	BXOR #xx:3, Rd	1						
	BXOR #xx:3, @ERd	2				1		
	BXOR #xx:3, @aa:8	2				1		
CMP	CMP.B #xx:8, Rd	1						
	CMP.B Rs, Rd	1						
	CMP.W #xx:16, Rd	2						
	CMP.W Rs, Rd	1						
	CMPL #xx:32, ERd	3						
	CMPL ERs, ERd	1						
DAA	DAA Rd	1						
DAS	DAS Rd	1						

Table A-4 Number of Cycles per Instruction (cont)

Instruction	Mnemonic	Instruction		Branch	Stack	Byte Data	Word Data	Internal	
		Fetch	Addr. Read	Addr. Read	Operation	Access	Access	Operation	
		I	J	K	L	M	N		
DEC	DEC.B Rd	1							
	DEC.W #1/2, Rd	1							
	DEC.L #1/2, ERd	1							
DIVXS	DIVXS.B Rs, Rd	2						12	
	DIVXS.W Rs, ERd	2						20	
DIVXU	DIVXU.B Rs, Rd	1						12	
	DIVXU.W Rs, ERd	1						20	
EEPMOV	EEPMOV.B	2				2n + 2*1			
	EEPMOV.W	2				2n + 2*1			
EXTS	EXTS.W Rd	1							
	EXTS.L ERd	1							
EXTU	EXTU.W Rd	1							
	EXTU.L ERd	1							
INC	INC.B Rd	1							
	INC.W #1/2, Rd	1							
	INC.L #1/2, ERd	1							
JMP	JMP @ERn	2							
	JMP @aa:24	2						2	
	JMP @@aa:8	Normal	2	1					2
		Advanced	2	2					2
JSR	JSR @ERn	Normal	2		1				
		Advanced	2		2				
	JSR @aa:24	Normal	2			1			2
		Advanced	2			2			2
	JSR @@aa:8	Normal	2	1	1				
		Advanced	2	2	2				
LDC	LDC #xx:8, CCR	1							
	LDC Rs, CCR	1							
	LDC @ERs, CCR	2					1		
	LDC @(d:16, ERs), CCR	3					1		
	LDC @(d:24, ERs), CCR	5					1		
	LDC @ERs+, CCR	2					1	2	
	LDC @aa:16, CCR	3					1		
	LDC @aa:24, CCR	4					1		

Table A-4 Number of Cycles per Instruction (cont)

Instruction	Mnemonic	Instruction	Branch	Stack	Byte Data	Word Data	Internal	
		Fetch	Addr. Read	Operation	Access	Access	Operation	
		I	J	K	L	M	N	
MOV	MOV.B #xx:8, Rd	1						
	MOV.B Rs, Rd	1						
	MOV.B @ERs, Rd	1			1			
	MOV.B @(d:16, ERs), Rd	2			1			
	MOV.B @(d:24, ERs), Rd	4			1			
	MOV.B @ERs+, Rd	1			1		2	
	MOV.B @aa:8, Rd	1			1			
	MOV.B @aa:16, Rd	2			1			
	MOV.B @aa:24, Rd	3			1			
	MOV.B Rs, @ERd	1			1			
	MOV.B Rs, @(d:16, ERd)	2			1			
	MOV.B Rs, @(d:24, ERd)	4			1			
	MOV.B Rs, @-ERd	1			1		2	
	MOV.B Rs, @aa:8	1			1			
	MOV.B Rs, @aa:16	2			1			
	MOV.B Rs, @aa:24	3			1			
	MOV.W #xx:16, Rd	2						
	MOV.W Rs, Rd	1						
	MOV.W @ERs, Rd	1					1	
	MOV.W @(d:16, ERs), Rd	2					1	
	MOV.W @(d:24, ERs), Rd	4					1	
	MOV.W @ERs+, Rd	1					1	2
	MOV.W @aa:16, Rd	2					1	
	MOV.W @aa:24, Rd	3					1	
	MOV.W Rs, @ERd	1					1	
	MOV.W Rs, @(d:16, ERd)	2					1	
	MOV.W Rs, @(d:24, ERd)	4					1	
	MOV.W Rs, @-ERd	1					1	2
	MOV.W Rs, @aa:16	2					1	
	MOV.W Rs, @aa:24	3					1	
	MOV.L #xx:32, ERd	3						
	MOV.L ERs, ERd	1						
	MOV.L @ERs, ERd	2					2	
	MOV.L @(d:16, ERs), ERd	3					2	
	MOV.L @(d:24, ERs), ERd	5					2	
	MOV.L @ERs+, ERd	2					2	2
	MOV.L @aa:16, ERd	3					2	
	MOV.L @aa:24, ERd	4					2	
	MOV.L ERs, @ERd	2					2	
	MOV.L ERs, @(d:16, ERd)	3					2	
	MOV.L ERs, @(d:24, ERd)	5					2	
	MOV.L ERs, @-ERd	2					2	2
MOV.L ERs, @aa:16	3					2		
MOV.L ERs, @aa:24	4					2		

Table A-4 Number of Cycles per Instruction (cont)

Instruction	Mnemonic	Instruction	Branch	Stack	Byte Data	Word Data	Internal
		Fetch I	Addr. Read J	Operation K	Access L	Access M	Operation N
MOVFP	MOVFP @aa:16, Rd*2	2			1		
MOVTPE	MOVTPE Rs, @aa:16*2	2			1		
MULXS	MULXS.B Rs, Rd	2					12
	MULXS.W Rs, ERd	2					20
MULXU	MULXU.B Rs, Rd	1					12
	MULXU.W Rs, ERd	1					20
NEG	NEG.B Rd	1					
	NEG.W Rd	1					
	NEG.L ERd	1					
NOP	NOP	1					
NOT	NOT.B Rd	1					
	NOT.W Rd	1					
	NOT.L ERd	1					
OR	OR.B #xx:8, Rd	1					
	OR.B Rs, Rd	1					
	OR.W #xx:16, Rd	2					
	OR.W Rs, Rd	1					
	OR.L #xx:32, ERd	3					
	OR.L ERs, ERd	2					
ORC	ORC #xx:8, CCR	1					
POP	POP.W Rn	1				1	2
	POP.L ERn	2				2	2
PUSH	PUSH.W Rn	1				1	2
	PUSH.L ERn	2				2	2
ROTL	ROTL.B Rd	1					
	ROTL.W Rd	1					
	ROTL.L ERd	1					
ROTR	ROTR.B Rd	1					
	ROTR.W Rd	1					
	ROTR.L ERd	1					
ROTXL	ROTXL.B Rd	1					
	ROTXL.W Rd	1					
	ROTXL.L ERd	1					
ROTXR	ROTXR.B Rd	1					
	ROTXR.W Rd	1					
	ROTXR.L ERd	1					
RTE	RTE	2		2		2	

Table A-4 Number of Cycles per Instruction (cont)

Instruction	Mnemonic		Instruction	Branch	Stack	Byte Data	Word Data	Internal
			Fetch	Addr. Read	Operation	Access	Access	Operation
			I	J	K	L	M	N
RTS	RTS	Normal	2			1		2
		Advanced	2		2			2
SHAL	SHAL.B Rd		1					
	SHAL.W Rd		1					
	SHAL.L ERd		1					
SHAR	SHAR.B Rd		1					
	SHAR.W Rd		1					
	SHAR.L ERd		1					
SHLL	SHLL.B Rd		1					
	SHLL.W Rd		1					
	SHLL.L ERd		1					
SHLR	SHLR.B Rd		1					
	SHLR.W Rd		1					
	SHLR.L ERd		1					
SLEEP	SLEEP		1					
STC	STC CCR, Rd		1					
	STC CCR, @ERd		2				1	
	STC CCR, @(d:16, ERd)		3				1	
	STC CCR, @(d:24, ERd)		5				1	
	STC CCR, @-ERd		2				1	2
	STC CCR, @aa:16		3				1	
	STC CCR, @aa:24		4				1	
SUB	SUB.B Rs, Rd		1					
	SUB.W #xx:16, Rd		2					
	SUB.W Rs, Rd		1					
	SUB.L #xx:32, ERd		3					
	SUB.L ERs, ERd		1					
SUBS	SUBS #1/2/4, ERd		1					
SUBX	SUBX #xx:8, Rd		1					
	SUBX Rs, Rd		1					
TRAPA	TRAPA #x:2	Normal	2	1	2			4
		Advanced	2	2	2			4
XOR	XOR.B #xx:8, Rd		1					
	XOR.B Rs, Rd		1					
	XOR.W #xx:16, Rd		2					
	XOR.W Rs, Rd		1					
	XOR.L #xx:32, ERd		3					
	XOR.L ERs, ERd		2					
XORC	XORC #xx:8, CCR		1					

Notes: 1. n is the value set in register R4L or R4. The source and destination are accessed n + 1 times each.
 2. Not available in the H8/3004 and H8/3005.

Appendix B Register Field

B.1 Register Addresses and Bit Names

Address (low)	Register Name	Data Bus Width	Bit Names								Module Name
			Bit 7	Bit 6	Bit 5	Bit 4	Bit 3	Bit 2	Bit 1	Bit 0	
H'1C											
H'1D											
H'1E											
H'1F											
H'20	—		—	—	—	—	—	—	—	—	
H'21	—		—	—	—	—	—	—	—	—	
H'22	—		—	—	—	—	—	—	—	—	
H'23	—		—	—	—	—	—	—	—	—	
H'24	—		—	—	—	—	—	—	—	—	
H'25	—		—	—	—	—	—	—	—	—	
H'26	—		—	—	—	—	—	—	—	—	
H'27	—		—	—	—	—	—	—	—	—	
H'28	—		—	—	—	—	—	—	—	—	
H'29	—		—	—	—	—	—	—	—	—	
H'2A	—		—	—	—	—	—	—	—	—	
H'2B	—		—	—	—	—	—	—	—	—	
H'2C	—		—	—	—	—	—	—	—	—	
H'2D	—		—	—	—	—	—	—	—	—	
H'2E	—		—	—	—	—	—	—	—	—	
H'2F	—		—	—	—	—	—	—	—	—	
H'30	—		—	—	—	—	—	—	—	—	
H'31	—		—	—	—	—	—	—	—	—	
H'32	—		—	—	—	—	—	—	—	—	
H'33	—		—	—	—	—	—	—	—	—	
H'34	—		—	—	—	—	—	—	—	—	
H'35	—		—	—	—	—	—	—	—	—	
H'36	—		—	—	—	—	—	—	—	—	
H'37	—		—	—	—	—	—	—	—	—	
H'38	—		—	—	—	—	—	—	—	—	
H'39	—		—	—	—	—	—	—	—	—	
H'3A	—		—	—	—	—	—	—	—	—	

Legend
DMAC: DMA controller

(Continued on next page)

(Continued from preceding page)

Address (low)	Register Name	Data Bus Width	Bit Names								Module Name
			Bit 7	Bit 6	Bit 5	Bit 4	Bit 3	Bit 2	Bit 1	Bit 0	
H'3B	—	—	—	—	—	—	—	—	—	—	—
H'3C	—	—	—	—	—	—	—	—	—	—	—
H'3D	—	—	—	—	—	—	—	—	—	—	—
H'3E	—	—	—	—	—	—	—	—	—	—	—
H'3F	—	—	—	—	—	—	—	—	—	—	—
H'40	—	—	—	—	—	—	—	—	—	—	—
H'41	—	—	—	—	—	—	—	—	—	—	—
H'42	—	—	—	—	—	—	—	—	—	—	—
H'43	—	—	—	—	—	—	—	—	—	—	—
H'44	—	—	—	—	—	—	—	—	—	—	—
H'45	—	—	—	—	—	—	—	—	—	—	—
H'46	—	—	—	—	—	—	—	—	—	—	—
H'47	—	—	—	—	—	—	—	—	—	—	—
H'48	—	—	—	—	—	—	—	—	—	—	—
H'49	—	—	—	—	—	—	—	—	—	—	—
H'4A	—	—	—	—	—	—	—	—	—	—	—
H'4B	—	—	—	—	—	—	—	—	—	—	—
H'4C	—	—	—	—	—	—	—	—	—	—	—
H'4D	—	—	—	—	—	—	—	—	—	—	—
H'4E	—	—	—	—	—	—	—	—	—	—	—
H'4F	—	—	—	—	—	—	—	—	—	—	—
H'50	—	—	—	—	—	—	—	—	—	—	—
H'51	—	—	—	—	—	—	—	—	—	—	—
H'52	—	—	—	—	—	—	—	—	—	—	—
H'53	—	—	—	—	—	—	—	—	—	—	—
H'54	—	—	—	—	—	—	—	—	—	—	—
H'55	—	—	—	—	—	—	—	—	—	—	—
H'56	—	—	—	—	—	—	—	—	—	—	—
H'57	—	—	—	—	—	—	—	—	—	—	—
H'58	—	—	—	—	—	—	—	—	—	—	—
H'59	—	—	—	—	—	—	—	—	—	—	—
H'5A	—	—	—	—	—	—	—	—	—	—	—
H'5B	—	—	—	—	—	—	—	—	—	—	—
H'5C	—	—	—	—	—	—	—	—	—	—	—
H'5D	—	—	—	—	—	—	—	—	—	—	—
H'5E	—	—	—	—	—	—	—	—	—	—	—
H'5F	—	—	—	—	—	—	—	—	—	—	—

(Continued on next page)

(Continued from preceding page)

Address (low)	Register Name	Data Bus Width	Bit Names								Module Name
			Bit 7	Bit 6	Bit 5	Bit 4	Bit 3	Bit 2	Bit 1	Bit 0	
H'60	TSTR	8	—	—	—	STR4	STR3	STR2	STR1	STR0	ITU (all channels)
H'61	TSNC	8	—	—	—	SYNC4	SYNC3	SYNC2	SYNC1	SYNC0	
H'62	TMDR	8	—	MDF	FDIR	PWM4	PWM3	PWM2	PWM1	PWM0	ITU channel 0
H'63	TFCR	8	—	—	CMD1	CMD0	BFB4	BFA4	BFB3	BFA3	
H'64	TCR0	8	—	CCLR1	CCLR0	CKEG1	CKEG0	TPSC2	TPSC1	TPSC0	ITU channel 0
H'65	TIOR0	8	—	IOB2	IOB1	IOB0	—	IOA2	IOA1	IOA0	
H'66	TIER0	8	—	—	—	—	—	OVIE	IMIEB	IMIEA	ITU channel 0
H'67	TSR0	8	—	—	—	—	—	OVF	IMFB	IMFA	
H'68	TCNT0H	16									
H'69	TCNT0L										
H'6A	GRA0H	16									
H'6B	GRA0L										
H'6C	GRB0H	16									
H'6D	GRB0L										
H'6E	TCR1	8	—	CCLR1	CCLR0	CKEG1	CKEG0	TPSC2	TPSC1	TPSC0	ITU channel 1
H'6F	TIOR1	8	—	IOB2	IOB1	IOB0	—	IOA2	IOA1	IOA0	
H'70	TIER1	8	—	—	—	—	—	OVIE	IMIEB	IMIEA	ITU channel 1
H'71	TSR1	8	—	—	—	—	—	OVF	IMFB	IMFA	
H'72	TCNT1H	16									
H'73	TCNT1L										
H'74	GRA1H	16									
H'75	GRA1L										
H'76	GRB1H	16									
H'77	GRB1L										
H'78	TCR2	8	—	CCLR1	CCLR0	CKEG1	CKEG0	TPSC2	TPSC1	TPSC0	ITU channel 2
H'79	TIOR2	8	—	IOB2	IOB1	IOB0	—	IOA2	IOA1	IOA0	
H'7A	TIER2	8	—	—	—	—	—	OVIE	IMIEB	IMIEA	ITU channel 2
H'7B	TSR2	8	—	—	—	—	—	OVF	IMFB	IMFA	
H'7C	TCNT2H	16									
H'7D	TCNT2L										
H'7E	GRA2H	16									
H'7F	GRA2L										
H'80	GRB2H	16									
H'81	GRB2L										

Legend

ITU: 16-bit integrated timer unit

(Continued on next page)

(Continued from preceding page)

Address (low)	Register Name	Data Bus Width	Bit Names								Module Name
			Bit 7	Bit 6	Bit 5	Bit 4	Bit 3	Bit 2	Bit 1	Bit 0	
H'82	TCR3	8	—	CCLR1	CCLR0	CKEG1	CKEG0	TPSC2	TPSC1	TPSC0	ITU channel 3
H'83	TIOR3	8	—	IOB2	IOB1	IOB0	—	IOA2	IOA1	IOA0	
H'84	TIER3	8	—	—	—	—	—	OVIE	IMIEB	IMIEA	
H'85	TSR3	8	—	—	—	—	—	OVF	IMFB	IMFA	
H'86	TCNT3H	16	_____								
H'87	TCNT3L	16	_____								
H'88	GRA3H	16	_____								
H'89	GRA3L	16	_____								
H'8A	GRB3H	16	_____								
H'8B	GRB3L	16	_____								
H'8C	BRA3H	16	_____								
H'8D	BRA3L	16	_____								
H'8E	BRB3H	16	_____								
H'8F	BRB3L	16	_____								
H'90	TOER	8	—	—	EXB4	EXA4	EB3	EB4	EA4	EA3	
H'91	TOCR	8	—	—	—	\overline{XTGD}	—	—	OLS4	OLS3	
H'92	TCR4	8	—	CCLR1	CCLR0	CKEG1	CKEG0	TPSC2	TPSC1	TPSC0	ITU channel 4
H'93	TIOR4	8	—	IOB2	IOB1	IOB0	—	IOA2	IOA1	IOA0	
H'94	TIER4	8	—	—	—	—	—	OVIE	IMIEB	IMIEA	
H'95	TSR4	8	—	—	—	—	—	OVF	IMFB	IMFA	
H'96	TCNT4H	16	_____								
H'97	TCNT4L	16	_____								
H'98	GRA4H	16	_____								
H'99	GRA4L	16	_____								
H'9A	GRB4H	16	_____								
H'9B	GRB4L	16	_____								
H'9C	BRA4H	16	_____								
H'9D	BRA4L	16	_____								
H'9E	BRB4H	16	_____								
H'9F	BRB4L	16	_____								

Legend

ITU: 16-bit integrated timer unit

(Continued on next page)

(Continued from preceding page)

Address (low)	Register Name	Data Bus Width	Bit Names								Module Name
			Bit 7	Bit 6	Bit 5	Bit 4	Bit 3	Bit 2	Bit 1	Bit 0	
H'A0	—	—	—	—	—	—	—	—	—	—	
H'A1	—	—	—	—	—	—	—	—	—	—	
H'A2	—	—	—	—	—	—	—	—	—	—	
H'A3	—	—	—	—	—	—	—	—	—	—	
H'A4	—	—	—	—	—	—	—	—	—	—	
H'A5	—	—	—	—	—	—	—	—	—	—	
H'A6	—	—	—	—	—	—	—	—	—	—	
H'A7	—	—	—	—	—	—	—	—	—	—	
H'A8	TCSR*1	8	OVF	WT/IT	TME	—	—	CKS2	CKS1	CKS0	WDT
H'A9	TCNT*1	8	—	—	—	—	—	—	—	—	
H'AA	—	—	—	—	—	—	—	—	—	—	
H'AB	RSTCSR*2	8	WRST	RSTOE	—	—	—	—	—	—	
H'AC	—	—	—	—	—	—	—	—	—	—	
H'AD	—	—	—	—	—	—	—	—	—	—	
H'AE	—	—	—	—	—	—	—	—	—	—	
H'AF	—	—	—	—	—	—	—	—	—	—	
H'B0	SMR	8	C/A	CHR	PE	O/E	STOP	MP	CKS1	CKS0	SCI channel 0
H'B1	BRR	8	—	—	—	—	—	—	—	—	
H'B2	SCR	8	TIE	RIE	TE	RE	MPIE	TEIE	CKE1	CKE0	
H'B3	TDR	8	—	—	—	—	—	—	—	—	
H'B4	SSR	8	TDRE	RDRF	ORER	FER	PER	TEND	MPB	MPBT	
H'B5	RDR	8	—	—	—	—	—	—	—	—	
H'B6	—	—	—	—	—	—	—	—	—	—	
H'B7	—	—	—	—	—	—	—	—	—	—	

Notes: 1. For write access to TCSR and TCNT, see section 10.2.4, Notes on Register Access.
 2. For write access to RSTCSR, see section 10.2.4, Notes on Register Access.

Legend
 WDT: Watchdog timer

(Continued on next page)

(Continued from preceding page)

Address (low)	Register Name	Data Bus Width	Bit Names								Module Name	
			Bit 7	Bit 6	Bit 5	Bit 4	Bit 3	Bit 2	Bit 1	Bit 0		
H'B8	—	—	—	—	—	—	—	—	—	—	—	
H'B9	—	—	—	—	—	—	—	—	—	—	—	
H'BA	—	—	—	—	—	—	—	—	—	—	—	
H'BB	—	—	—	—	—	—	—	—	—	—	—	
H'BC	—	—	—	—	—	—	—	—	—	—	—	
H'BD	—	—	—	—	—	—	—	—	—	—	—	
H'BE	—	—	—	—	—	—	—	—	—	—	—	
H'BF	—	—	—	—	—	—	—	—	—	—	—	
H'C0	—	—	—	—	—	—	—	—	—	—	—	
H'C1	—	—	—	—	—	—	—	—	—	—	—	
H'C2	—	—	—	—	—	—	—	—	—	—	—	
H'C3	—	—	—	—	—	—	—	—	—	—	—	
H'C4	—	—	—	—	—	—	—	—	—	—	—	
H'C5	—	—	—	—	—	—	—	—	—	—	—	
H'C6	—	—	—	—	—	—	—	—	—	—	—	
H'C7	—	—	—	—	—	—	—	—	—	—	—	
H'C8	—	—	—	—	—	—	—	—	—	—	—	
H'C9	P6DDR	8	—	—	—	—	—	—	—	—	P6 ₀ DDR	Port 6
H'CA	—	—	—	—	—	—	—	—	—	—	—	
H'CB	P6DR	8	—	—	—	—	—	—	—	—	P6 ₀	
H'CC	—	—	—	—	—	—	—	—	—	—	—	
H'CD	P8DDR	8	—	—	—	—	—	P8 ₃ DDR	P8 ₂ DDR	P8 ₁ DDR	P8 ₀ DDR	Port 8
H'CE	P7DR	8	P7 ₇	P7 ₆	P7 ₅	P7 ₄	P7 ₃	P7 ₂	P7 ₁	P7 ₀	—	Port 7
H'CF	P8DR	8	—	—	—	—	P8 ₃	P8 ₂	P8 ₁	P8 ₀	—	Port 8
H'D0	P9DDR	8	—	—	—	P9 ₄ DDR	—	P9 ₂ DDR	—	P9 ₀ DDR	—	Port 9
H'D1	PADDR	8	PA ₇ DDR	PA ₆ DDR	PA ₅ DDR	PA ₄ DDR	PA ₃ DDR	PA ₂ DDR	PA ₁ DDR	PA ₀ DDR	—	Port A
H'D2	P9DR	8	—	—	—	P9 ₄	—	P9 ₂	—	P9 ₀	—	Port 9
H'D3	PADR	8	PA ₇	PA ₆	PA ₅	PA ₄	PA ₃	PA ₂	PA ₁	PA ₀	—	Port A
H'D4	PBDDR	8	PB ₇ DDR	PB ₆ DDR	PB ₅ DDR	PB ₄ DDR	PB ₃ DDR	PB ₂ DDR	PB ₁ DDR	PB ₀ DDR	—	Port B
H'D5	—	8	—	—	—	—	—	—	—	—	—	
H'D6	PBDR	8	PB ₇	PB ₆	PB ₅	PB ₄	PB ₃	PB ₂	PB ₁	PB ₀	—	Port B
H'D7	—	8	—	—	—	—	—	—	—	—	—	

(Continued on next page)

(Continued from preceding page)

Address (low)	Register Name	Data Bus Width	Bit Names								Module Name	
			Bit 7	Bit 6	Bit 5	Bit 4	Bit 3	Bit 2	Bit 1	Bit 0		
H'D8	—	—	—	—	—	—	—	—	—	—	—	
H'D9	—	—	—	—	—	—	—	—	—	—	—	
H'DA	—	—	—	—	—	—	—	—	—	—	—	
H'DB	—	—	—	—	—	—	—	—	—	—	—	
H'DC	—	—	—	—	—	—	—	—	—	—	—	
H'DD	—	—	—	—	—	—	—	—	—	—	—	
H'DE	—	—	—	—	—	—	—	—	—	—	—	
H'DF	—	—	—	—	—	—	—	—	—	—	—	
H'E0	ADDRAH	8	AD9	AD8	AD7	AD6	AD5	AD4	AD3	AD2	AD1	A/D
H'E1	ADDRAL	8	AD1	AD0	—	—	—	—	—	—	—	
H'E2	ADDRBH	8	AD9	AD8	AD7	AD6	AD5	AD4	AD3	AD2	AD1	
H'E3	ADDRBL	8	AD1	AD0	—	—	—	—	—	—	—	
H'E4	ADDRCH	8	AD9	AD8	AD7	AD6	AD5	AD4	AD3	AD2	AD1	
H'E5	ADDRCL	8	AD1	AD0	—	—	—	—	—	—	—	
H'E6	ADDRDH	8	AD9	AD8	AD7	AD6	AD5	AD4	AD3	AD2	AD1	
H'E7	ADDRDL	8	AD1	AD0	—	—	—	—	—	—	—	
H'E8	ADCSR	8	ADF	ADIE	ADST	SCAN	CKS	CH2	CH1	CH0	CH0	
H'E9	ADCR	8	TRGE	—	—	—	—	—	—	—	—	
H'EA	—	—	—	—	—	—	—	—	—	—	—	
H'EB	—	—	—	—	—	—	—	—	—	—	—	
H'EC	—	—	—	—	—	—	—	—	—	—	—	Bus controller
H'ED	ASTCR	8	AST7	AST6	AST5	AST4	AST3	AST2	AST1	AST0	AST0	
H'EE	WCR	8	—	—	—	—	WMS1	WMS0	WC1	WC0	WC0	
H'EF	WCER	8	WCE7	WCE6	WCE5	WCE4	WCE3	WCE2	WCE1	WCE0	WCE0	

Legend
A/D: A/D converter

(Continued on next page)

(Continued from preceding page)

Address (low)	Register Name	Data Bus Width	Bit Names								Module Name	
			Bit 7	Bit 6	Bit 5	Bit 4	Bit 3	Bit 2	Bit 1	Bit 0		
H'F0	—	—	—	—	—	—	—	—	—	—	—	
H'F1	MDCR	8	—	—	—	—	—	—	—	MDS1	MDS0	System control
H'F2	SYSCR	8	SSBY	STS2	STS1	STS0	UE	NMIEG	—	RAME	—	
H'F3	—	—	—	—	—	—	—	—	—	—	—	
H'F4	ISCR	8	—	—	—	IRQ4SC	IRQ3SC	IRQ2SC	IRQ1SC	IRQ0SC	—	Interrupt controller
H'F5	IER	8	—	—	—	IRQ4E	IRQ3E	IRQ2E	IRQ1E	IRQ0E	—	
H'F6	ISR	8	—	—	—	IRQ4F	IRQ3F	IRQ2F	IRQ1F	IRQ0F	—	
H'F7	—	—	—	—	—	—	—	—	—	—	—	
H'F8	IPRA	8	IPRA7	IPRA6	IPRA5	IPRA4	IPRA3	IPRA2	IPRA1	IPRA0	—	Interrupt controller
H'F9	IPRB	8	IPRB7	IPRB6	—	—	IPRB3	—	IPRB1	—	—	
H'FA	—	—	—	—	—	—	—	—	—	—	—	
H'FB	—	—	—	—	—	—	—	—	—	—	—	
H'FC	—	—	—	—	—	—	—	—	—	—	—	
H'FD	—	—	—	—	—	—	—	—	—	—	—	
H'FE	—	—	—	—	—	—	—	—	—	—	—	
H'FF	—	—	—	—	—	—	—	—	—	—	—	

B.2 Register Descriptions

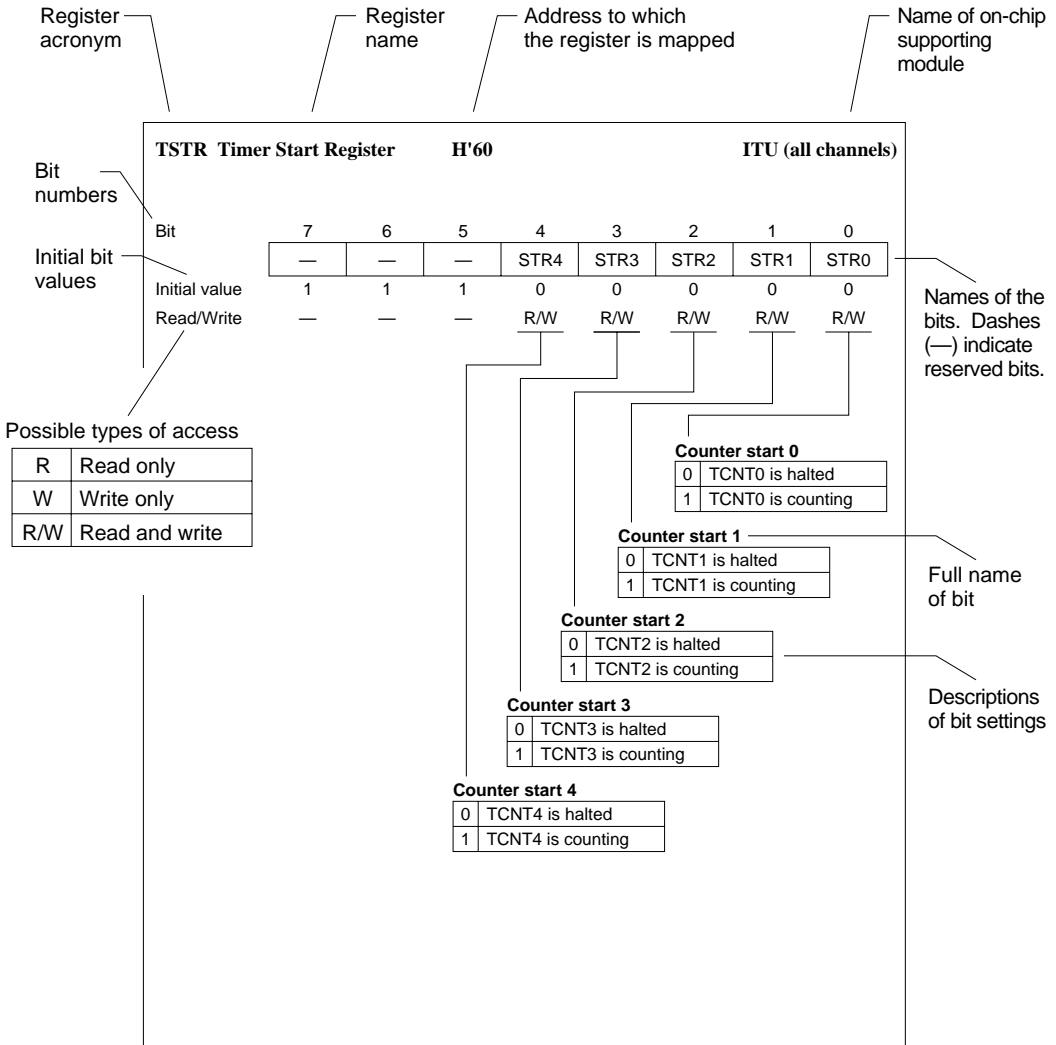

TSTR—Timer Start Register

H'60 ITU (all channels)

Bit	7	6	5	4	3	2	1	0
	—	—	—	STR4	STR3	STR2	STR1	STR0
Initial value	1	1	1	0	0	0	0	0
Read/Write	—	—	—	R/W	R/W	R/W	R/W	R/W

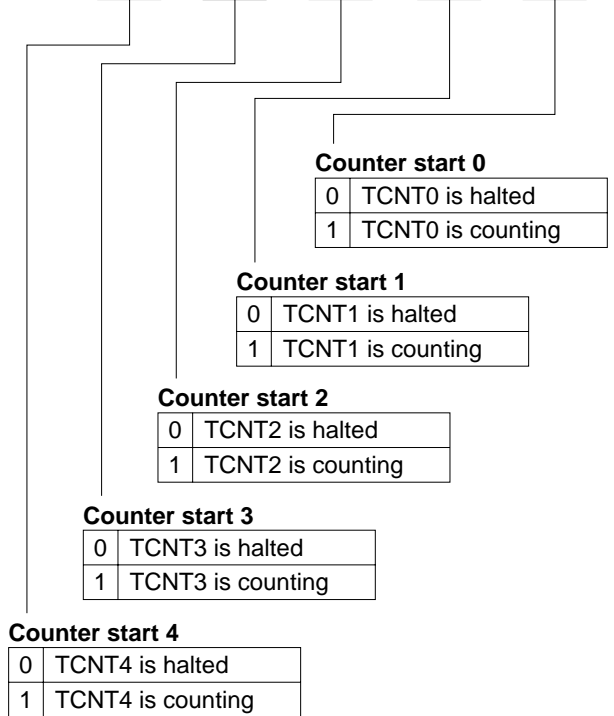

Bit	7	6	5	4	3	2	1	0
	—	—	—	SYNC4	SYNC3	SYNC2	SYNC1	SYNC0
Initial value	1	1	1	0	0	0	0	0
Read/Write	—	—	—	R/W	R/W	R/W	R/W	R/W

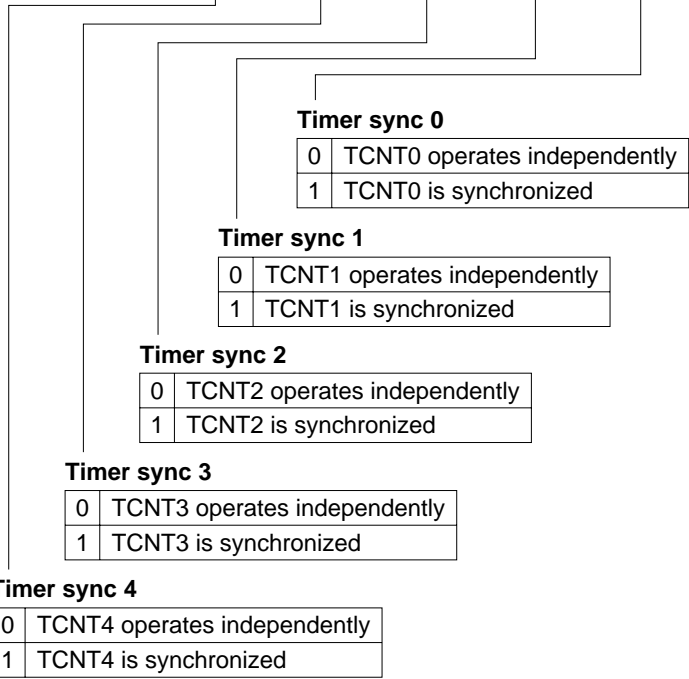

Bit	7	6	5	4	3	2	1	0
	—	MDF	FDIR	PWM4	PWM3	PWM2	PWM1	PWM0
Initial value	1	0	0	0	0	0	0	0
Read/Write	—	R/W	R/W	R/W	R/W	R/W	R/W	R/W

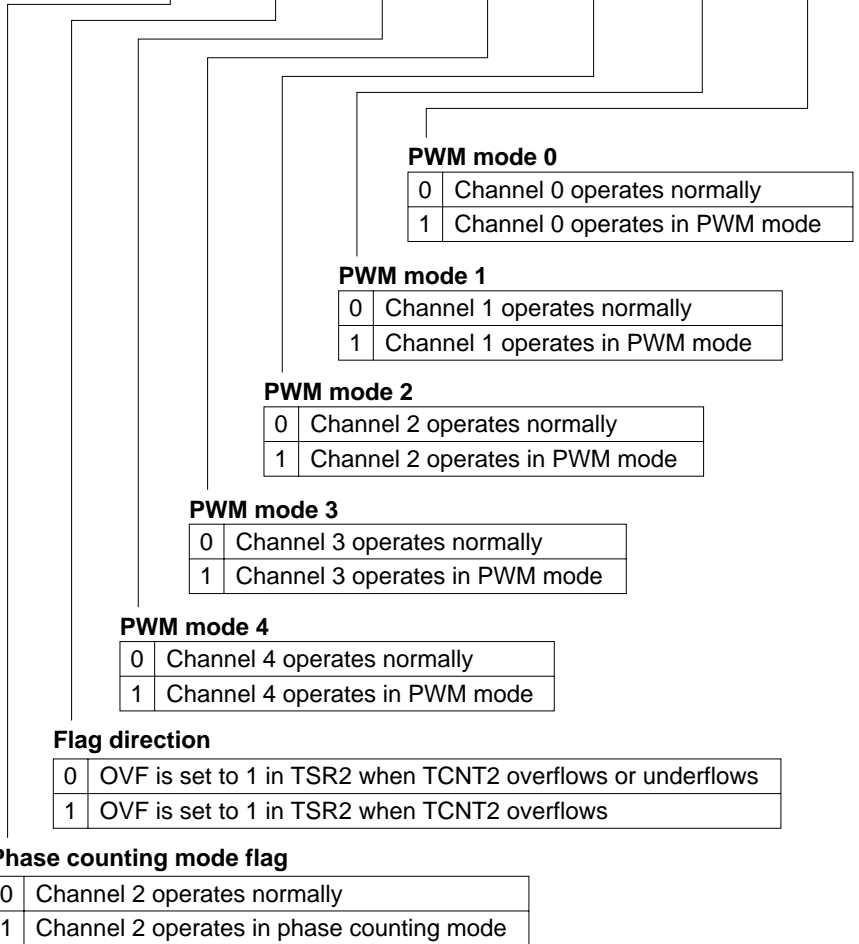

Bit	7	6	5	4	3	2	1	0
	—	—	CMD1	CMD0	BFB4	BFA4	BFB3	BFA3
Initial value	1	1	0	0	0	0	0	0
Read/Write	—	—	R/W	R/W	R/W	R/W	R/W	R/W

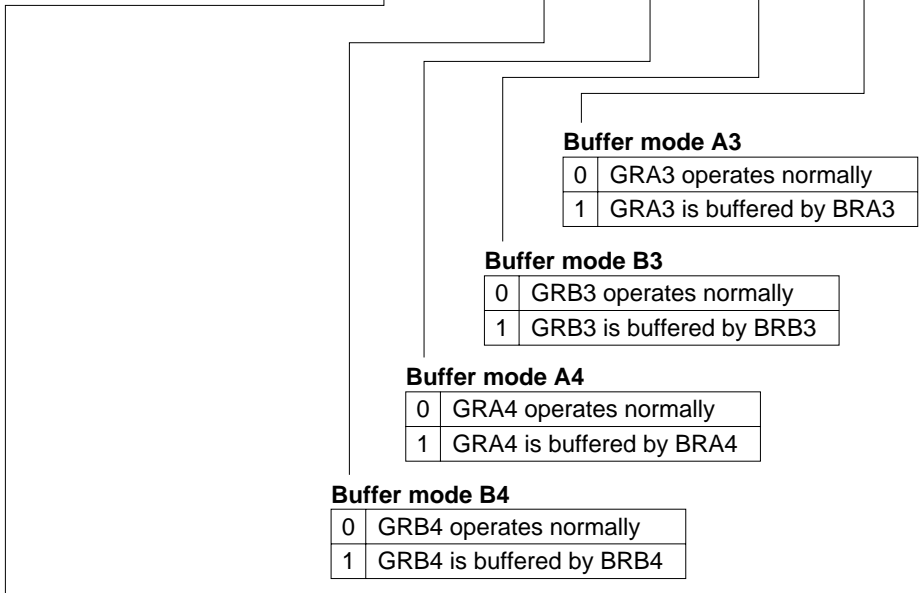

Combination mode 1 and 0

Bit 5	Bit 4	
CMD1	CMD0	Operating Mode of Channels 3 and 4
0	0	Channels 3 and 4 operate normally
	1	
1	0	Channels 3 and 4 operate together in complementary PWM mode
	1	Channels 3 and 4 operate together in reset-synchronized PWM mode

Bit	7	6	5	4	3	2	1	0
	—	CCLR1	CCLR0	CKEG1	CKEG0	TPSC2	TPSC1	TPSC0
Initial value	1	0	0	0	0	0	0	0
Read/Write	—	R/W	R/W	R/W	R/W	R/W	R/W	R/W

Timer prescaler 2 to 0

Bit 2	Bit 1	Bit 0	TCNT Clock Source
TPSC2	TPSC1	TPSC0	
0	0	0	Internal clock: \emptyset
		1	Internal clock: $\emptyset/2$
	1	0	Internal clock: $\emptyset/4$
		1	Internal clock: $\emptyset/8$
1	0	0	External clock A: TCLKA input
		1	External clock B: TCLKB input
	1	0	External clock C: TCLKC input
		1	External clock D: TCLKD input

Clock edge 1 and 0

Bit 4	Bit 3	Counted Edges of External Clock
CKEG1	CKEG0	
0	0	Rising edges counted
	1	Falling edges counted
1	—	Both edges counted

Counter clear 1 and 0

Bit 6	Bit 5	TCNT Clear Source
CCLR1	CCLR0	
0	0	TCNT is not cleared
	1	TCNT is cleared by GRA compare match or input capture
1	0	TCNT is cleared by GRB compare match or input capture
	1	Synchronous clear: TCNT is cleared in synchronization with other synchronized timers

Bit	7	6	5	4	3	2	1	0
	—	IOB2	IOB1	IOB0	—	IOA2	IOA1	IOA0
Initial value	1	0	0	0	1	0	0	0
Read/Write	—	R/W	R/W	R/W	—	R/W	R/W	R/W

I/O control A2 to A0

Bit 2	Bit 1	Bit 0	GRA Function	
IOA2	IOA1	IOA0		
0	0	0	GRA is an output compare register	No output at compare match
		1		0 output at GRA compare match
	1	0		1 output at GRA compare match
		1		Output toggles at GRA compare match
1	0	0	GRA is an input capture register	GRA captures rising edge of input
		1		GRA captures falling edge of input
	1	0		GRA captures both edges of input
		1		

I/O control B2 to B0

Bit 6	Bit 5	Bit 4	GRB Function	
IOB2	IOB1	IOB0		
0	0	0	GRB is an output compare register	No output at compare match
		1		0 output at GRB compare match
	1	0		1 output at GRB compare match
		1		Output toggles at GRB compare match
1	0	0	GRB is an input capture register	GRB captures rising edge of input
		1		GRB captures falling edge of input
	1	0		GRB captures both edges of input
		1		

Bit	7	6	5	4	3	2	1	0
	—	—	—	—	—	OVIE	IMIEB	IMIEA
Initial value	1	1	1	1	1	0	0	0
Read/Write	—	—	—	—	—	R/W	R/W	R/W

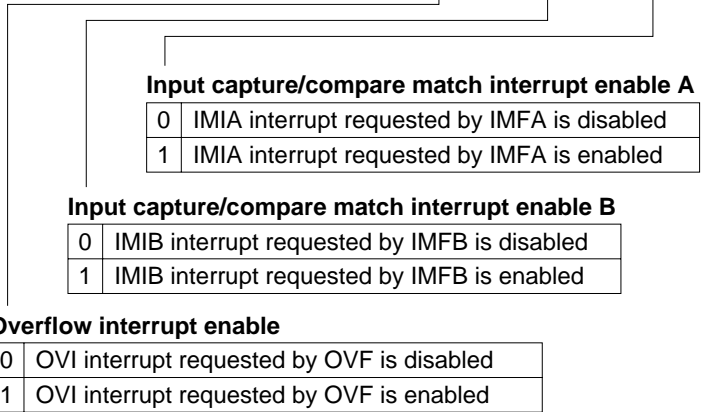

Bit	7	6	5	4	3	2	1	0
	—	—	—	—	—	OVF	IMFB	IMFA
Initial value	1	1	1	1	1	0	0	0
Read/Write	—	—	—	—	—	R/(W)*	R/(W)*	R/(W)*

Input capture/compare match flag A

0	[Clearing condition] Read IMFA when IMFA = 1, then write 0 in IMFA
1	[Setting conditions] TCNT = GRA when GRA functions as a compare match register. TCNT value is transferred to GRA by an input capture signal, when GRA functions as an input capture register.

Input capture/compare match flag B

0	[Clearing condition] Read IMFB when IMFB = 1, then write 0 in IMFB
1	[Setting conditions] TCNT = GRB when GRB functions as a compare match register. TCNT value is transferred to GRB by an input capture signal, when GRB functions as an input capture register.

Overflow flag

0	[Clearing condition] Read OVF when OVF = 1, then write 0 in OVF
1	[Setting condition] TCNT overflowed from H'FFFF to H'0000

Note: * Only 0 can be written, to clear the flag.

TCNT0 H/L—Timer Counter 0 H/L**H'68, H'69****ITU0**

Bit	15	14	13	12	11	10	9	8	7	6	5	4	3	2	1	0
Initial value	0	0	0	0	0	0	0	0	0	0	0	0	0	0	0	0
Read/Write	R/W	R/W	R/W	R/W	R/W	R/W	R/W	R/W	R/W	R/W	R/W	R/W	R/W	R/W	R/W	R/W

|
Up-counter

GRA0 H/L—General Register A0 H/L**H'6A, H'6B****ITU0**

Bit	15	14	13	12	11	10	9	8	7	6	5	4	3	2	1	0
Initial value	1	1	1	1	1	1	1	1	1	1	1	1	1	1	1	1
Read/Write	R/W	R/W	R/W	R/W	R/W	R/W	R/W	R/W	R/W	R/W	R/W	R/W	R/W	R/W	R/W	R/W

|
Output compare or input capture register

GRB0 H/L—General Register B0 H/L**H'6C, H'6D****ITU0**

Bit	15	14	13	12	11	10	9	8	7	6	5	4	3	2	1	0
Initial value	1	1	1	1	1	1	1	1	1	1	1	1	1	1	1	1
Read/Write	R/W	R/W	R/W	R/W	R/W	R/W	R/W	R/W	R/W	R/W	R/W	R/W	R/W	R/W	R/W	R/W

|
Output compare or input capture register

TCR1—Timer Control Register 1**H'6E****ITU1**

Bit	7	6	5	4	3	2	1	0
	—	CCLR1	CCLR0	CKEG1	CKEG0	TPSC2	TPSC1	TPSC0
Initial value	1	0	0	0	0	0	0	0
Read/Write	—	R/W	R/W	R/W	R/W	R/W	R/W	R/W

Note: Bit functions are the same as for ITU0.

TIOR1—Timer I/O Control Register 1**H'6F****ITU1**

Bit	7	6	5	4	3	2	1	0
	—	IOB2	IOB1	IOB0	—	IOA2	IOA1	IOA0
Initial value	1	0	0	0	1	0	0	0
Read/Write	—	R/W	R/W	R/W	—	R/W	R/W	R/W

Note: Bit functions are the same as for ITU0.

TIER1—Timer Interrupt Enable Register 1**H'70****ITU1**

Bit	7	6	5	4	3	2	1	0
	—	—	—	—	—	OVIE	IMIEB	IMIEA
Initial value	1	1	1	1	1	0	0	0
Read/Write	—	—	—	—	—	R/W	R/W	R/W

Note: Bit functions are the same as for ITU0.

TSR1—Timer Status Register 1**H'71****ITU1**

Bit	7	6	5	4	3	2	1	0
	—	—	—	—	—	OVF	IMFB	IMFA
Initial value	1	1	1	1	1	0	0	0
Read/Write	—	—	—	—	—	R/(W)*	R/(W)*	R/(W)*

Notes: Bit functions are the same as for ITU0.

* Only 0 can be written, to clear the flag.

TCNT1 H/L—Timer Counter 1 H/L**H'72, H'73****ITU1**

Bit	15	14	13	12	11	10	9	8	7	6	5	4	3	2	1	0
Initial value	0	0	0	0	0	0	0	0	0	0	0	0	0	0	0	0
Read/Write	R/W	R/W	R/W	R/W	R/W	R/W	R/W	R/W	R/W	R/W	R/W	R/W	R/W	R/W	R/W	R/W

Note: Bit functions are the same as for ITU0.

GRA1 H/L—General Register A1 H/L**H'74, H'75****ITU1**

Bit	15	14	13	12	11	10	9	8	7	6	5	4	3	2	1	0
	<input type="checkbox"/>	<input type="checkbox"/>	<input type="checkbox"/>	<input type="checkbox"/>	<input type="checkbox"/>	<input type="checkbox"/>	<input type="checkbox"/>	<input type="checkbox"/>	<input type="checkbox"/>	<input type="checkbox"/>	<input type="checkbox"/>	<input type="checkbox"/>	<input type="checkbox"/>	<input type="checkbox"/>	<input type="checkbox"/>	<input type="checkbox"/>
Initial value	1	1	1	1	1	1	1	1	1	1	1	1	1	1	1	1
Read/Write	R/W	R/W	R/W	R/W	R/W	R/W	R/W	R/W	R/W	R/W	R/W	R/W	R/W	R/W	R/W	R/W

Note: Bit functions are the same as for ITU0.

GRB1 H/L—General Register B1 H/L**H'76, H'77****ITU1**

Bit	15	14	13	12	11	10	9	8	7	6	5	4	3	2	1	0
	<input type="checkbox"/>	<input type="checkbox"/>	<input type="checkbox"/>	<input type="checkbox"/>	<input type="checkbox"/>	<input type="checkbox"/>	<input type="checkbox"/>	<input type="checkbox"/>	<input type="checkbox"/>	<input type="checkbox"/>	<input type="checkbox"/>	<input type="checkbox"/>	<input type="checkbox"/>	<input type="checkbox"/>	<input type="checkbox"/>	<input type="checkbox"/>
Initial value	1	1	1	1	1	1	1	1	1	1	1	1	1	1	1	1
Read/Write	R/W	R/W	R/W	R/W	R/W	R/W	R/W	R/W	R/W	R/W	R/W	R/W	R/W	R/W	R/W	R/W

Note: Bit functions are the same as for ITU0.

TCR2—Timer Control Register 2**H'78****ITU2**

Bit	7	6	5	4	3	2	1	0
	<input type="checkbox"/>	<input type="checkbox"/>	<input type="checkbox"/>	<input type="checkbox"/>	<input type="checkbox"/>	<input type="checkbox"/>	<input type="checkbox"/>	<input type="checkbox"/>
	—	CCLR1	CCLR0	CKEG1	CKEG0	TPSC2	TPSC1	TPSC0
Initial value	1	0	0	0	0	0	0	0
Read/Write	—	R/W	R/W	R/W	R/W	R/W	R/W	R/W

Notes: 1. Bit functions are the same as for ITU0.

2. When channel 2 is used in phase counting mode, the counter clock source selection by bits TPSC2 to TPSC0 is ignored.

TIOR2—Timer I/O Control Register 2**H'79****ITU2**

Bit	7	6	5	4	3	2	1	0
	—	IOB2	IOB1	IOB0	—	IOA2	IOA1	IOA0
Initial value	1	0	0	0	1	0	0	0
Read/Write	—	R/W	R/W	R/W	—	R/W	R/W	R/W

Note: Bit functions are the same as for ITU0.

TIER2—Timer Interrupt Enable Register 2
H'7A
ITU2

Bit	7	6	5	4	3	2	1	0
	—	—	—	—	—	OVIE	IMIEB	IMIEA
Initial value	1	1	1	1	1	0	0	0
Read/Write	—	—	—	—	—	R/W	R/W	R/W

Note: Bit functions are the same as for ITU0.

TSR2—Timer Status Register 2
H'7B
ITU2

Bit	7	6	5	4	3	2	1	0
	—	—	—	—	—	OVF	IMFB	IMFA
Initial value	1	1	1	1	1	0	0	0
Read/Write	—	—	—	—	—	R/(W)*	R/(W)*	R/(W)*

Overflow flag

0	[Clearing condition] Read OVF when OVF = 1, then write 0 in OVF
1	[Setting condition] TCNT overflowed from H'FFFF to H'0000 or underflowed from H'0000 to H'FFFF

Bit functions are the same as for ITU0.

Note: * Only 0 can be written, to clear the flag.

TCNT2 H/L—Timer Counter 2 H/L
H'7C, H'7D
ITU2

Bit	15	14	13	12	11	10	9	8	7	6	5	4	3	2	1	0
Initial value	0	0	0	0	0	0	0	0	0	0	0	0	0	0	0	0
Read/Write	R/W	R/W	R/W	R/W	R/W	R/W	R/W	R/W	R/W	R/W	R/W	R/W	R/W	R/W	R/W	R/W

Phase counting mode: up/down counter
Other modes: up-counter

GRA2 H/L—General Register A2 H/L**H'7E, H'7F****ITU2**

Bit	15	14	13	12	11	10	9	8	7	6	5	4	3	2	1	0
	<input type="checkbox"/>	<input type="checkbox"/>	<input type="checkbox"/>	<input type="checkbox"/>	<input type="checkbox"/>	<input type="checkbox"/>	<input type="checkbox"/>	<input type="checkbox"/>	<input type="checkbox"/>	<input type="checkbox"/>	<input type="checkbox"/>	<input type="checkbox"/>	<input type="checkbox"/>	<input type="checkbox"/>	<input type="checkbox"/>	<input type="checkbox"/>
Initial value	1	1	1	1	1	1	1	1	1	1	1	1	1	1	1	1
Read/Write	R/W	R/W	R/W	R/W	R/W	R/W	R/W	R/W	R/W	R/W	R/W	R/W	R/W	R/W	R/W	R/W

Note: Bit functions are the same as for ITU0.

GRB2 H/L—General Register B2 H/L**H'80, H'81****ITU2**

Bit	15	14	13	12	11	10	9	8	7	6	5	4	3	2	1	0
	<input type="checkbox"/>	<input type="checkbox"/>	<input type="checkbox"/>	<input type="checkbox"/>	<input type="checkbox"/>	<input type="checkbox"/>	<input type="checkbox"/>	<input type="checkbox"/>	<input type="checkbox"/>	<input type="checkbox"/>	<input type="checkbox"/>	<input type="checkbox"/>	<input type="checkbox"/>	<input type="checkbox"/>	<input type="checkbox"/>	<input type="checkbox"/>
Initial value	1	1	1	1	1	1	1	1	1	1	1	1	1	1	1	1
Read/Write	R/W	R/W	R/W	R/W	R/W	R/W	R/W	R/W	R/W	R/W	R/W	R/W	R/W	R/W	R/W	R/W

Note: Bit functions are the same as for ITU0.

TCR3—Timer Control Register 3**H'82****ITU3**

Bit	7	6	5	4	3	2	1	0
	<input type="checkbox"/>	CCLR1	CCLR0	CKEG1	CLEG0	TPSC2	TPSC1	TPSC0
Initial value	1	0	0	0	0	0	0	0
Read/Write	—	R/W	R/W	R/W	R/W	R/W	R/W	R/W

Note: Bit functions are the same as for ITU0.

TIOR3—Timer I/O Control Register 3**H'83****ITU3**

Bit	7	6	5	4	3	2	1	0
	<input type="checkbox"/>	IOB2	IOB1	IOB0	<input type="checkbox"/>	IOA2	IOA1	IOA0
Initial value	1	0	0	0	1	0	0	0
Read/Write	—	R/W	R/W	R/W	—	R/W	R/W	R/W

Note: Bit functions are the same as for ITU0.

TIER3—Timer Interrupt Enable Register 3
H'84
ITU3

Bit	7	6	5	4	3	2	1	0
	—	—	—	—	—	OVIE	IMIEB	IMIEA
Initial value	1	1	1	1	1	0	0	0
Read/Write	—	—	—	—	—	R/W	R/W	R/W

Note: Bit functions are the same as for ITU0.

TSR3—Timer Status Register 3
H'85
ITU3

Bit	7	6	5	4	3	2	1	0
	—	—	—	—	—	OVF	IMFB	IMFA
Initial value	1	1	1	1	1	0	0	0
Read/Write	—	—	—	—	—	R/(W)*	R/(W)*	R/(W)*

Bit functions are the same as for ITU0

Overflow flag

0	[Clearing condition] Read OVF when OVF = 1, then write 0 in OVF
1	[Setting condition] TCNT overflowed from H'FFFF to H'0000 or underflowed from H'0000 to H'FFFF

Note: * Only 0 can be written, to clear the flag.

TCNT3 H/L—Timer Counter 3 H/L
H'86, H'87
ITU3

Bit	15	14	13	12	11	10	9	8	7	6	5	4	3	2	1	0
Initial value	0	0	0	0	0	0	0	0	0	0	0	0	0	0	0	0
Read/Write	R/W	R/W	R/W	R/W	R/W	R/W	R/W	R/W	R/W	R/W	R/W	R/W	R/W	R/W	R/W	R/W

 Complementary PWM mode: up/down counter
 Other modes: up-counter

GRA3 H/L—General Register A3 H/L**H'88, H'89****ITU3**

Bit	15	14	13	12	11	10	9	8	7	6	5	4	3	2	1	0
Initial value	1	1	1	1	1	1	1	1	1	1	1	1	1	1	1	1
Read/Write	R/W	R/W	R/W	R/W	R/W	R/W	R/W	R/W	R/W	R/W	R/W	R/W	R/W	R/W	R/W	R/W

Output compare or input capture register (can be buffered)

GRB3 H/L—General Register B3 H/L**H'8A, H'8B****ITU3**

Bit	15	14	13	12	11	10	9	8	7	6	5	4	3	2	1	0
Initial value	1	1	1	1	1	1	1	1	1	1	1	1	1	1	1	1
Read/Write	R/W	R/W	R/W	R/W	R/W	R/W	R/W	R/W	R/W	R/W	R/W	R/W	R/W	R/W	R/W	R/W

Output compare or input capture register (can be buffered)

BRA3 H/L—Buffer Register A3 H/L**H'8C, H'8D****ITU3**

Bit	15	14	13	12	11	10	9	8	7	6	5	4	3	2	1	0
Initial value	1	1	1	1	1	1	1	1	1	1	1	1	1	1	1	1
Read/Write	R/W	R/W	R/W	R/W	R/W	R/W	R/W	R/W	R/W	R/W	R/W	R/W	R/W	R/W	R/W	R/W

Used to buffer GRA

BRB3 H/L—Buffer Register B3 H/L**H'8E, H'8F****ITU3**

Bit	15	14	13	12	11	10	9	8	7	6	5	4	3	2	1	0
Initial value	1	1	1	1	1	1	1	1	1	1	1	1	1	1	1	1
Read/Write	R/W	R/W	R/W	R/W	R/W	R/W	R/W	R/W	R/W	R/W	R/W	R/W	R/W	R/W	R/W	R/W

Used to buffer GRB

Bit	7	6	5	4	3	2	1	0
	—	—	EXB4	EXA4	EB3	EB4	EA4	EA3
Initial value	1	1	1	1	1	1	1	1
Read/Write	—	—	R/W	R/W	R/W	R/W	R/W	R/W

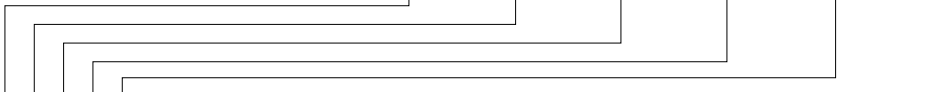

Master enable TIOCA3

0	TIOCA ₃ output is disabled regardless of TIOR3, TMDR, and TFCR settings
1	TIOCA ₃ is enabled for output according to TIOR3, TMDR, and TFCR settings

Master enable TIOCA4

0	TIOCA ₄ output is disabled regardless of TIOR4, TMDR, and TFCR settings
1	TIOCA ₄ is enabled for output according to TIOR4, TMDR, and TFCR settings

Master enable TIOCB4

0	TIOCB ₄ output is disabled regardless of TIOR4 and TFCR settings
1	TIOCB ₄ is enabled for output according to TIOR4 and TFCR settings

Master enable TIOCB3

0	TIOCB ₃ output is disabled regardless of TIOR3 and TFCR settings
1	TIOCB ₃ is enabled for output according to TIOR3 and TFCR settings

Master enable TOCXA4

0	TOCXA ₄ output is disabled regardless of TFCR settings
1	TOCXA ₄ is enabled for output according to TFCR settings

Master enable TOCXB4

0	TOCXB ₄ output is disabled regardless of TFCR settings
1	TOCXB ₄ is enabled for output according to TFCR settings

TOCR—Timer Output Control Register

H'91

ITU (all channels)

Bit	7	6	5	4	3	2	1	0
	—	—	—	XTGD	—	—	OLS4	OLS3
Initial value	1	1	1	1	1	1	1	1
Read/Write	—	—	—	R/W	—	—	R/W	R/W

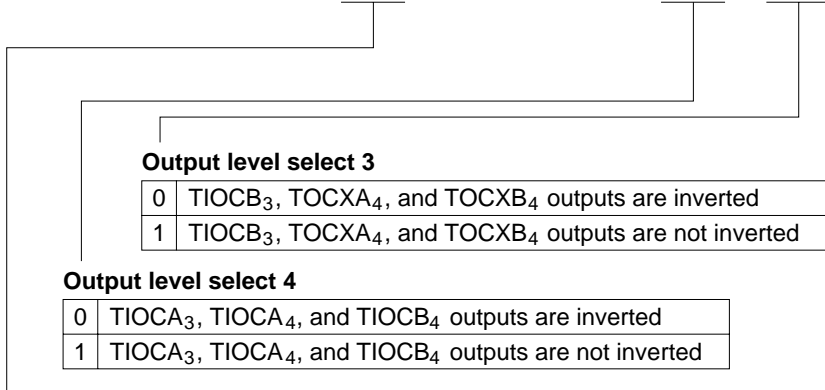

Output level select 3

0	TIOCB ₃ , TOCXA ₄ , and TOCXB ₄ outputs are inverted
1	TIOCB ₃ , TOCXA ₄ , and TOCXB ₄ outputs are not inverted

Output level select 4

0	TIOCA ₃ , TIOCA ₄ , and TIOCB ₄ outputs are inverted
1	TIOCA ₃ , TIOCA ₄ , and TIOCB ₄ outputs are not inverted

External trigger disable

0	Input capture A in channel 1 is used as an external trigger signal in reset-synchronized PWM mode and complementary PWM mode*
1	External triggering is disabled

Note: *When an external trigger occurs, bits 5 to 0 in TOER are cleared to 0, disabling ITU output.

TCR4—Timer Control Register 4**H'92****ITU4**

Bit	7	6	5	4	3	2	1	0
	—	CCLR1	CCLR0	CKEG1	CKEG0	TPSC2	TPSC1	TPSC0
Initial value	1	0	0	0	0	0	0	0
Read/Write	—	R/W	R/W	R/W	R/W	R/W	R/W	R/W

Note: Bit functions are the same as for ITU0.

TIOR4—Timer I/O Control Register 4**H'93****ITU4**

Bit	7	6	5	4	3	2	1	0
	—	IOB2	IOB1	IOB0	—	IOA2	IOA1	IOA0
Initial value	1	0	0	0	1	0	0	0
Read/Write	—	R/W	R/W	R/W	—	R/W	R/W	R/W

Note: Bit functions are the same as for ITU0.

TIER4—Timer Interrupt Enable Register 4**H'94****ITU4**

Bit	7	6	5	4	3	2	1	0
	—	—	—	—	—	OVIE	IMIEB	IMIEA
Initial value	1	1	1	1	1	0	0	0
Read/Write	—	—	—	—	—	R/W	R/W	R/W

Note: Bit functions are the same as for ITU0.

TSR4—Timer Status Register 4**H'95****ITU4**

Bit	7	6	5	4	3	2	1	0
	—	—	—	—	—	OVF	IMFB	IMFA
Initial value	1	1	1	1	1	0	0	0
Read/Write	—	—	—	—	—	R/(W)*	R/(W)*	R/(W)*

Notes: Bit functions are the same as for ITU0.

* Only 0 can be written, to clear the flag.

TCNT4 H/L—Timer Counter 4 H/L**H'96, H'97****ITU4**

Bit	15	14	13	12	11	10	9	8	7	6	5	4	3	2	1	0
	<input type="checkbox"/>	<input type="checkbox"/>	<input type="checkbox"/>	<input type="checkbox"/>	<input type="checkbox"/>	<input type="checkbox"/>	<input type="checkbox"/>	<input type="checkbox"/>	<input type="checkbox"/>	<input type="checkbox"/>	<input type="checkbox"/>	<input type="checkbox"/>	<input type="checkbox"/>	<input type="checkbox"/>	<input type="checkbox"/>	<input type="checkbox"/>
Initial value	0	0	0	0	0	0	0	0	0	0	0	0	0	0	0	0
Read/Write	R/W	R/W	R/W	R/W	R/W	R/W	R/W	R/W	R/W	R/W	R/W	R/W	R/W	R/W	R/W	R/W

Note: Bit functions are the same as for ITU3.

GRA4 H/L—General Register A4 H/L**H'98, H'99****ITU4**

Bit	15	14	13	12	11	10	9	8	7	6	5	4	3	2	1	0
	<input type="checkbox"/>	<input type="checkbox"/>	<input type="checkbox"/>	<input type="checkbox"/>	<input type="checkbox"/>	<input type="checkbox"/>	<input type="checkbox"/>	<input type="checkbox"/>	<input type="checkbox"/>	<input type="checkbox"/>	<input type="checkbox"/>	<input type="checkbox"/>	<input type="checkbox"/>	<input type="checkbox"/>	<input type="checkbox"/>	<input type="checkbox"/>
Initial value	1	1	1	1	1	1	1	1	1	1	1	1	1	1	1	1
Read/Write	R/W	R/W	R/W	R/W	R/W	R/W	R/W	R/W	R/W	R/W	R/W	R/W	R/W	R/W	R/W	R/W

Note: Bit functions are the same as for ITU3.

GRB4 H/L—General Register B4 H/L**H'9A, H'9B****ITU4**

Bit	15	14	13	12	11	10	9	8	7	6	5	4	3	2	1	0
	<input type="checkbox"/>	<input type="checkbox"/>	<input type="checkbox"/>	<input type="checkbox"/>	<input type="checkbox"/>	<input type="checkbox"/>	<input type="checkbox"/>	<input type="checkbox"/>	<input type="checkbox"/>	<input type="checkbox"/>	<input type="checkbox"/>	<input type="checkbox"/>	<input type="checkbox"/>	<input type="checkbox"/>	<input type="checkbox"/>	<input type="checkbox"/>
Initial value	1	1	1	1	1	1	1	1	1	1	1	1	1	1	1	1
Read/Write	R/W	R/W	R/W	R/W	R/W	R/W	R/W	R/W	R/W	R/W	R/W	R/W	R/W	R/W	R/W	R/W

Note: Bit functions are the same as for ITU3.

BRA4 H/L—Buffer Register A4 H/L**H'9C, H'9D****ITU4**

Bit	15	14	13	12	11	10	9	8	7	6	5	4	3	2	1	0
	<input type="checkbox"/>	<input type="checkbox"/>	<input type="checkbox"/>	<input type="checkbox"/>	<input type="checkbox"/>	<input type="checkbox"/>	<input type="checkbox"/>	<input type="checkbox"/>	<input type="checkbox"/>	<input type="checkbox"/>	<input type="checkbox"/>	<input type="checkbox"/>	<input type="checkbox"/>	<input type="checkbox"/>	<input type="checkbox"/>	<input type="checkbox"/>
Initial value	1	1	1	1	1	1	1	1	1	1	1	1	1	1	1	1
Read/Write	R/W	R/W	R/W	R/W	R/W	R/W	R/W	R/W	R/W	R/W	R/W	R/W	R/W	R/W	R/W	R/W

Note: Bit functions are the same as for ITU3.

Bit	15	14	13	12	11	10	9	8	7	6	5	4	3	2	1	0
Initial value	1	1	1	1	1	1	1	1	1	1	1	1	1	1	1	1
Read/Write	R/W	R/W	R/W	R/W	R/W	R/W	R/W	R/W	R/W	R/W	R/W	R/W	R/W	R/W	R/W	R/W

Note: Bit functions are the same as for ITU3.

TCSR—Timer Control/Status Register

H'A8

WDT

Bit	7	6	5	4	3	2	1	0
	OVF	WT/ $\bar{I}T$	TME	—	—	CKS2	CKS1	CKS0
Initial value	0	0	0	1	1	0	0	0
Read/Write	R/(W)*	R/W	R/W	—	—	R/W	R/W	R/W

Timer enable

0	Timer disabled <ul style="list-style-type: none"> • TCNT is initialized to H'00 and halted
1	Timer enabled <ul style="list-style-type: none"> • TCNT is counting • CPU interrupt requests are enabled

Timer mode select

0	Interval timer: requests interval timer interrupts
1	Watchdog timer: generates a reset signal

Clock select 2 to 0

0	0	0	$\emptyset/2$
		1	$\emptyset/32$
	1	0	$\emptyset/64$
		1	$\emptyset/128$
1	0	0	$\emptyset/256$
		1	$\emptyset/512$
	1	0	$\emptyset/2048$
		1	$\emptyset/4096$

Overflow flag

0	[Clearing condition] Read OVF when OVF = 1, then write 0 in OVF
1	[Setting condition] TCNT changes from H'FF to H'00

Note: * Only 0 can be written, to clear the flag.

TCNT—Timer Counter**H'A9 (read),
H'A8 (write)****WDT**

Bit	7	6	5	4	3	2	1	0
Initial value	0	0	0	0	0	0	0	0
Read/Write	R/W	R/W	R/W	R/W	R/W	R/W	R/W	R/W

Count value

RSTCSR—Reset Control/Status Register**H'AB (read),
H'AA (write)****WDT**

Bit	7	6	5	4	3	2	1	0
	WRST	RSTOE	—	—	—	—	—	—
Initial value	0	0	1	1	1	1	1	1
Read/Write	R/(W)*	R/W	—	—	—	—	—	—

Reset output enable

0	Reset signal is not output externally
1	Reset signal is output externally

Watchdog timer reset

0	[Clearing condition] Reset signal input at $\overline{\text{RES}}$ pin, or 0 written by software
1	[Setting condition] TCNT overflow generates a reset signal

Note: * Only 0 can be written in bit 7, to clear the flag.

Bit	7	6	5	7	3	2	1	0
	C/ \bar{A}	CHR	PE	O/ \bar{E}	STOP	MP	CKS1	CKS0
Initial value	0	0	0	0	0	0	0	0
Read/Write	R/W	R/W	R/W	R/W	R/W	R/W	R/W	R/W

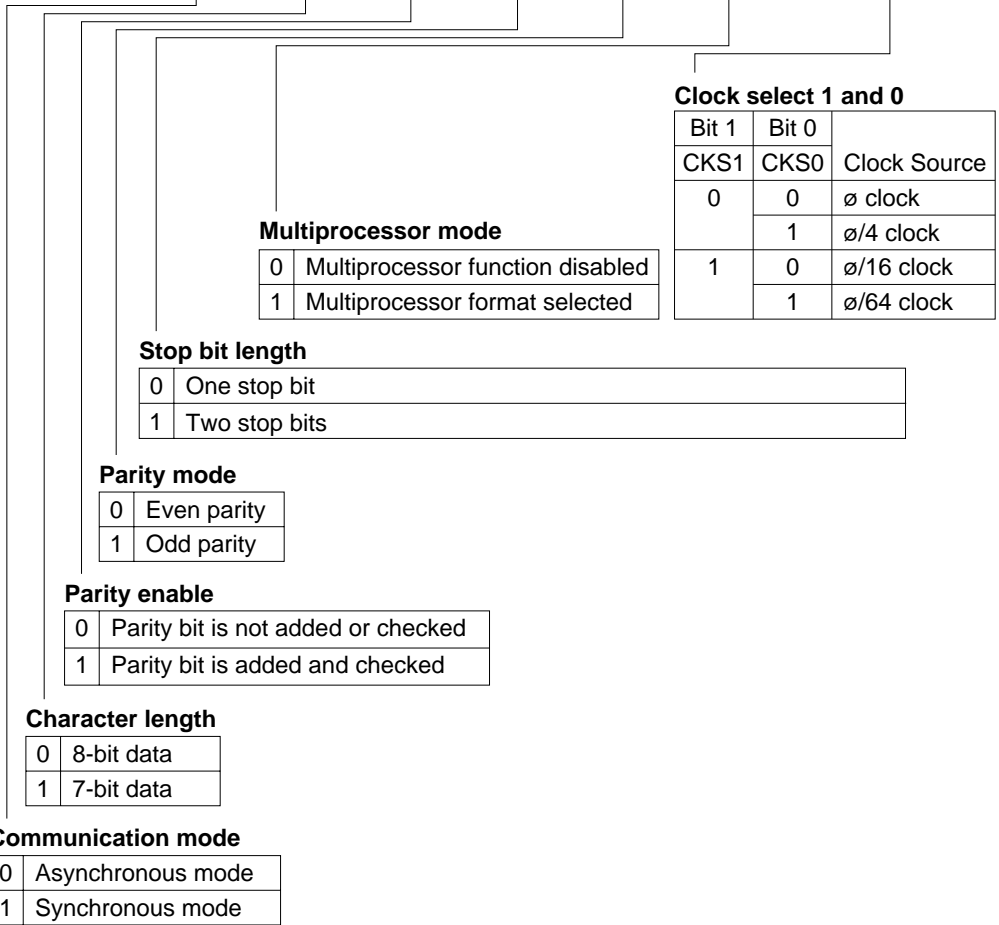

BRR—Bit Rate Register

H'B1

SCI

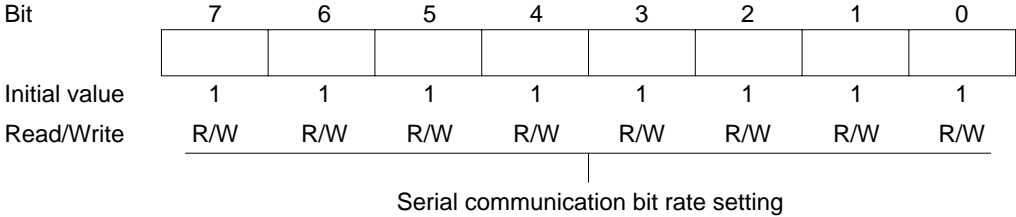

Bit	7	6	5	4	3	2	1	0
	TIE	RIE	TE	RE	MPIE	TEIE	CKE1	CKE0
Initial value	0	0	0	0	0	0	0	0
Read/Write	R/W	R/W	R/W	R/W	R/W	R/W	R/W	R/W

Clock enable 1 and 0

Bit 1	Bit 2	Clock Selection and Output	
CKE1	CKE2		
0	0	Asynchronous mode	Internal clock, SCK pin available for generic input
		Synchronous mode	Internal clock, SCK pin used for serial clock output
	1	Asynchronous mode	Internal clock, SCK pin used for clock output
		Synchronous mode	Internal clock, SCK pin used for serial clock output
1	0	Asynchronous mode	External clock, SCK pin used for clock input
		Synchronous mode	External clock, SCK pin used for serial clock input
	1	Asynchronous mode	External clock, SCK pin used for clock input
		Synchronous mode	External clock, SCK pin used for serial clock input

Transmit-end interrupt enable

0	Transmit-end interrupt requests (TEI) are disabled
1	Transmit-end interrupt requests (TEI) are enabled

Multiprocessor interrupt enable

0	Multiprocessor interrupts are disabled (normal receive operation)
1	Multiprocessor interrupts are enabled

Transmit enable

0	Transmitting is disabled
1	Transmitting is enabled

Receive enable

0	Transmitting is disabled
1	Transmitting is enabled

Receive interrupt enable

0	Receive-data-full (RXI) and receive-error (ERI) interrupt requests are disabled
1	Receive-data-full (RXI) and receive-error (ERI) interrupt requests are enabled

Transmit interrupt enable

0	Transmit-data-empty interrupt request (TXI) is disabled
1	Transmit-data-empty interrupt request (TXI) is enabled

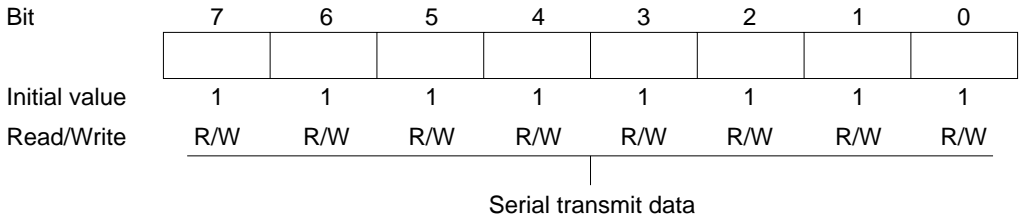
TDR—Transmit Data Register**H'B3****SCI**

Bit	7	6	5	4	3	2	1	0
	TDRE	RDRF	ORER	FER	PER	TEND	MPB	MPBT
Initial value	1	0	0	0	0	1	0	0
Read/Write	R/(W)*	R/(W)*	R/(W)*	R/(W)*	R/(W)*	R	R	R/W

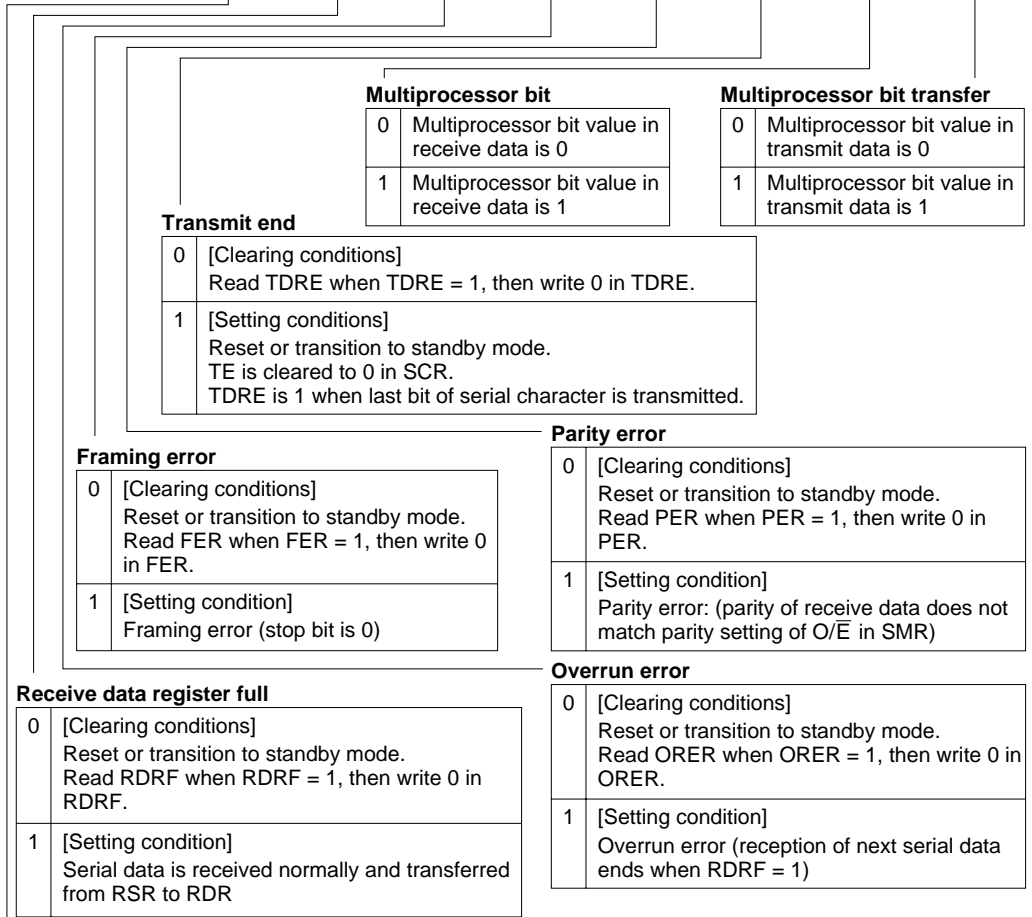

Note: * Only 0 can be written, to clear the flag.

RDR—Receive Data Register**H'B5****SCI**

Bit	7	6	5	4	3	2	1	0
Initial value	0	0	0	0	0	0	0	0
Read/Write	R	R	R	R	R	R	R	R

Serial receive data

P6DDR—Port 6 Data Direction Register**H'C9****Port 6**

Bit	7	6	5	4	3	2	1	0
	—	—	—	—	—	—	—	P6 ₀ DDR
Initial value	1	0	0	0	0	0	0	0
Read/Write	—	W	W	W	W	W	W	W

Port 6 input/output select

0	Generic input
1	Generic output

P6DR—Port 6 Data Register**H'CB****Port 6**

Bit	7	6	5	4	3	2	1	0
	—	—	—	—	—	—	—	P6 ₀
Initial value	1	0	0	0	0	0	0	0
Read/Write	—	R/W	R/W	R/W	R/W	R/W	R/W	R/W

Data for port 6 pins

P8DDR—Port 8 Data Direction Register**H'CD****Port 8**

Bit	7	6	5	4	3	2	1	0
	—	—	—	—	P8 ₃ DDR	P8 ₂ DDR	P8 ₁ DDR	P8 ₀ DDR
Initial value	1	1	1	0	0	0	0	0
Read/Write	—	—	—	W	W	W	W	W

Port 8 input/output select

0	Generic input
1	Generic output

P7DR—Port 7 Data Register**H'CE****Port 7**

Bit	7	6	5	4	3	2	1	0
	P7 ₇	P7 ₆	P7 ₅	P7 ₄	P7 ₃	P7 ₂	P7 ₁	P7 ₀
Initial value	—*	—*	—*	—*	—*	—*	—*	—*
Read/Write	R	R	R	R	R	R	R	R

Data for port 7 pins

Note: * Determined by pins P7₇ to P7₀.**P8DR—Port 8 Data Register****H'CF****Port 8**

Bit	7	6	5	4	3	2	1	0
	—	—	—	—	P8 ₃	P8 ₂	P8 ₁	P8 ₀
Initial value	1	1	1	0	0	0	0	0
Read/Write	—	—	—	R/W	R/W	R/W	R/W	R/W

Data for port 8 pins

P9DDR—Port 9 Data Direction Register**H'D0****Port 9**

Bit	7	6	5	4	3	2	1	0
	—	—	—	P9 ₄ DDR	—	P9 ₂ DDR	—	P9 ₀ DDR
Initial value	1	1	0	0	0	0	0	0
Read/Write	—	—	W	W	W	W	W	W

Port 9 input/output select

0	Generic input
1	Generic output

PADDR—Port A Data Direction Register**H'D1****Port A**

Bit	7	6	5	4	3	2	1	0
	PA ₇ DDR	PA ₆ DDR	PA ₅ DDR	PA ₄ DDR	PA ₃ DDR	PA ₂ DDR	PA ₁ DDR	PA ₀ DDR
Mode 1								
Initial value	0	0	0	0	0	0	0	0
Read/Write	W	W	W	W	W	W	W	W
Mode 3								
Initial value	1	0	0	0	0	0	0	0
Read/Write	—	W	W	W	W	W	W	W

Port A input/output select

0	Generic input
1	Generic output

P9DR—Port 9 Data Register**H'D2****Port 9**

Bit	7	6	5	4	3	2	1	0
	—	—	—	P9 ₄	—	P9 ₂	—	P9 ₀
Initial value	1	1	0	0	0	0	0	0
Read/Write	—	—	R/W	R/W	R/W	R/W	R/W	R/W

Data for port 9 pins

Bit	7	6	5	4	3	2	1	0
	PA ₇	PA ₆	PA ₅	PA ₄	PA ₃	PA ₂	PA ₁	PA ₀
Initial value	0	0	0	0	0	0	0	0
Read/Write	R/W	R/W	R/W	R/W	R/W	R/W	R/W	R/W

Data for port A pins

Bit	7	6	5	4	3	2	1	0
	PB ₇ DDR	PB ₆ DDR	PB ₅ DDR	PB ₄ DDR	PB ₃ DDR	PB ₂ DDR	PB ₁ DDR	PB ₀ DDR
Initial value	0	0	0	0	0	0	0	0
Read/Write	W	W	W	W	W	W	W	W

Port B input/output select

0	Generic input
1	Generic output

Bit	7	6	5	4	3	2	1	0
	PB ₇	PB ₆	PB ₅	PB ₄	PB ₃	PB ₂	PB ₁	PB ₀
Initial value	0	0	0	0	0	0	0	0
Read/Write	R/W	R/W	R/W	R/W	R/W	R/W	R/W	R/W

Data for port B pins

PADR—Port A Data Register**H'D3****Port A**

Bit	15	14	13	12	11	10	9	8	7	6	5	4	3	2	1	0
	AD9	AD8	AD7	AD6	AD5	AD4	AD3	AD2	AD1	AD0	—	—	—	—	—	—
Initial value	0	0	0	0	0	0	0	0	0	0	0	0	0	0	0	0
Read/Write	R	R	R	R	R	R	R	R	R	R	R	R	R	R	R	R

└──────────────────────────────────┘
└──────────────────────────────────┘

ADDRAH
ADDRAL

A/D conversion data

10-bit data giving an A/D conversion result

PBDDR—Port B Data Direction Register**H'D4****Port B**

Bit	15	14	13	12	11	10	9	8	7	6	5	4	3	2	1	0
	AD9	AD8	AD7	AD6	AD5	AD4	AD3	AD2	AD1	AD0	—	—	—	—	—	—
Initial value	0	0	0	0	0	0	0	0	0	0	0	0	0	0	0	0
Read/Write	R	R	R	R	R	R	R	R	R	R	R	R	R	R	R	R

└──────────────────────────────────┘
└──────────────────────────────────┘

ADDRBH
ADDRBL

A/D conversion data

10-bit data giving an A/D conversion result

PBDR—Port B Data Register**H'D6****Port B**

Bit	15	14	13	12	11	10	9	8	7	6	5	4	3	2	1	0
	AD9	AD8	AD7	AD6	AD5	AD4	AD3	AD2	AD1	AD0	—	—	—	—	—	—
Initial value	0	0	0	0	0	0	0	0	0	0	0	0	0	0	0	0
Read/Write	R	R	R	R	R	R	R	R	R	R	R	R	R	R	R	R

└──────────────────────────────────┘
└──────────────────────────────────┘

ADDRCH
ADDRCL

A/D conversion data

10-bit data giving an A/D conversion result

ADDRA H/L—A/D Data Register A H/L**H'E0, H'E1****A/D**

Bit	15	14	13	12	11	10	9	8	7	6	5	4	3	2	1	0
	AD9	AD8	AD7	AD6	AD5	AD4	AD3	AD2	AD1	AD0	—	—	—	—	—	—
Initial value	0	0	0	0	0	0	0	0	0	0	0	0	0	0	0	0
Read/Write	R	R	R	R	R	R	R	R	R	R	R	R	R	R	R	R
	ADDRDH									ADDRDL						
	A/D conversion data 10-bit data giving an A/D conversion result															

ADDRB H/L—A/D Data Register B H/L**H'E2, H'E3****A/D**

Bit	7	6	5	4	3	2	1	0				
	TRGE	—	—	—	—	—	—	—				
Initial value	0	1	1	1	1	1	1	1				
Read/Write	R/W	—	—	—	—	—	—	—				
	Trigger enable											
	<table border="1"> <tr> <td>0</td> <td>A/D conversion cannot be externally triggered</td> </tr> <tr> <td>1</td> <td>A/D conversion starts at the fall of the external trigger signal ($\overline{\text{ADTRG}}$)</td> </tr> </table>								0	A/D conversion cannot be externally triggered	1	A/D conversion starts at the fall of the external trigger signal ($\overline{\text{ADTRG}}$)
0	A/D conversion cannot be externally triggered											
1	A/D conversion starts at the fall of the external trigger signal ($\overline{\text{ADTRG}}$)											

ADDRC H/L—A/D Data Register C H/L**H'E4, H'E5****A/D**

Bit	7	6	5	4	3	2	1	0
	ADF	ADIE	ADST	SCAN	CKS	CH2	CH1	CH0
Initial value	0	0	0	0	0	0	0	0
Read/Write	R/(W)*	R/W	R/W	R/W	R/W	R/W	R/W	R/W

Clock select

0	Conversion time = 266 states (maximum)
1	Conversion time = 134 states (maximum)

Channel select 2 to 0

Group Selection	Channel Selection			Description	
CH2	CH1	CH0	Single Mode	Scan Mode	
0	0	0	AN ₀	AN ₀	
		1	AN ₁	AN ₀ , AN ₁	
	1	0	AN ₂	AN ₀ to AN ₂	
		1	AN ₃	AN ₀ to AN ₃	
1	0	0	AN ₄	AN ₄	
		1	AN ₅	AN ₄ , AN ₅	
	1	0	AN ₆	AN ₄ to AN ₆	
		1	AN ₇	AN ₄ to AN ₇	

Scan mode

0	Single mode
1	Scan mode

A/D start

0	A/D conversion is stopped
1	Single mode: A/D conversion starts; ADST is automatically cleared to 0 when conversion ends Scan mode: A/D conversion starts and continues, cycling among the selected channels, until ADST is cleared to 0 by software, by a reset, or by a transition to standby mode

A/D interrupt enable

0	A/D end interrupt request is disabled
1	A/D end interrupt request is enabled

A/D end flag

0	[Clearing condition] Read ADF while ADF = 1, then write 0 in ADF
1	[Setting conditions] Single mode: A/D conversion ends Scan mode: A/D conversion ends in all selected channels

Note: * Only 0 can be written, to clear flag.

Bit	7	6	5	4	3	2	1	0
	AST7	AST6	AST5	AST4	AST3	AST2	AST1	AST0
Initial value	1	1	1	1	1	1	1	1
Read/Write	R/W	R/W	R/W	R/W	R/W	R/W	R/W	R/W

Area 7 to 0 access state control

Bits 7 to 0	Number of States in Access Cycle
AST7 to AST0	
0	Areas 7 to 0 are two-state access areas
1	Areas 7 to 0 are three-state access areas

ADCR—A/D Control Register

H'E9

A/D

Bit	7	6	5	4	3	2	1	0
	—	—	—	—	WMS1	WMS0	WC1	WC0
Initial value	1	1	1	1	0	0	1	1
Read/Write	—	—	—	—	R/W	R/W	R/W	R/W

Wait mode select 1 and 0

Bit 3	Bit 2	Wait Mode
WMS1	WMS0	
0	0	Programmable wait mode
	1	No wait states inserted by wait-state controller
1	0	Pin wait mode
	1	Pin auto-wait mode

Wait count 1 and 0

Bit 1	Bit 0	Number of Wait States
WC1	WC0	
0	0	No wait states inserted by wait-state controller
	1	1 state inserted
1	0	2 states inserted
	1	3 states inserted

ADCSR—A/D Control/Status Register**H'E8****A/D**

Bit	7	6	5	4	3	2	1	0
	WCE7	WCE6	WCE5	WCE4	WCE3	WCE2	WCE1	WCE0
Initial value	1	1	1	1	1	1	1	1
Read/Write	R/W	R/W	R/W	R/W	R/W	R/W	R/W	R/W

Wait state controller enable 7 to 0

0	Wait-state control is disabled (pin wait mode 0)
1	Wait-state control is enabled

ASTCR—Access State Control Register**H'ED****Bus controller**

Bit	7	6	5	4	3	2	1	0
	—	—	—	—	—	—	MDS1	MDS0
Initial value	1	1	0	0	0	0	—*	—*
Read/Write	—	—	—	—	—	—	R	R

Mode select 1 and 0

Bit 1	Bit 0	Operating mode
MD ₁	MD ₀	
0	0	—
	1	Mode 1
1	0	—
	1	Mode 3

Note: * Determined by the state of the mode pins (MD₁ and MD₀).**WCR—Wait Control Register****H'EE****Bus controller**

WCER—Wait Controller Enable Register

H'EF

Bus controller

Bit	7	6	5	4	3	2	1	0
	SSBY	STS2	STS1	STS0	UE	NMIEG	—	RAME
Initial value	0	0	0	0	1	0	1	1
Read/Write	R/W	R/W	R/W	R/W	R/W	R/W	—	R/W

RAM enable

0	On-chip RAM is disabled
1	On-chip RAM is enabled

NMI edge select

0	An interrupt is requested at the falling edge of NMI
1	An interrupt is requested at the rising edge of NMI

User bit enable

0	CCR bit 6 (UI) is used as an interrupt mask bit
1	CCR bit 6 (UI) is used as a user bit

Standby timer select 2 to 0

Bit 6	Bit 5	Bit 4	Standby Timer
STS2	STS1	STS0	
0	0	0	Waiting time = 8192 states
		1	Waiting time = 16384 states
	1	0	Waiting time = 32768 states
		1	Waiting time = 65536 states
1	0	—	Waiting time = 131072 states
	1	—	Illegal setting

Software standby

0	SLEEP instruction causes transition to sleep mode
1	SLEEP instruction causes transition to software standby mode

MDCR—Mode Control Register

H'F1

System control

Bit	7	6	5	4	3	2	1	0
	—	—	—	IRQ4SC	IRQ3SC	IRQ2SC	IRQ1SC	IRQ0SC
Initial value	0	0	0	0	0	0	0	0
Read/Write	R/W	R/W	R/W	R/W	R/W	R/W	R/W	R/W

IRQ₄ to IRQ₀ sense control

0	Interrupts are requested when $\overline{\text{IRQ}}_4$ to $\overline{\text{IRQ}}_0$ inputs are low
1	Interrupts are requested by falling-edge input at $\overline{\text{IRQ}}_4$ to $\overline{\text{IRQ}}_0$

Bit	7	6	5	4	3	2	1	0
	—	—	—	IRQ4E	IRQ3E	IRQ2E	IRQ1E	IRQ0E
Initial value	0	0	0	0	0	0	0	0
Read/Write	R/(W)	R/(W)	R/(W)	R/(W)	R/(W)	R/(W)	R/(W)	R/(W)

IRQ₄ to IRQ₀ enable

0	IRQ ₄ to IRQ ₀ interrupts are disabled
1	IRQ ₄ to IRQ ₀ interrupts are enabled

ISCR—IRQ Sense Control Register

H'F4 Interrupt controller

Bit	7	6	5	4	3	2	1	0
	—	—	—	IRQ4F	IRQ3F	IRQ2F	IRQ1F	IRQ0F
Initial value	0	0	0	0	0	0	0	0
Read/Write	—	—	—	R/(W)*	R/(W)*	R/(W)*	R/(W)*	R/(W)*

IRQ₄ to IRQ₀ flags

Bits 4 to 0	
IRQ4F to IRQ0F	Setting and Clearing Conditions
0	[Clearing conditions] Read IRQ _n F when $\overline{\text{IRQ}}_n\text{F} = 1$, then write 0 in $\overline{\text{IRQ}}_n\text{F}$. IRQ _n SC = 0, $\overline{\text{IRQ}}_n$ input is high, and interrupt exception handling is carried out. IRQ _n SC = 1 and $\overline{\text{IRQ}}_n$ interrupt exception handling is carried out.
1	[Setting conditions] IRQ _n SC = 0 and $\overline{\text{IRQ}}_n$ input is low. IRQ _n SC = 1 and $\overline{\text{IRQ}}_n$ input changes from high to low.

(n = 4 to 0)

Note: * Only 0 can be written, to clear the flag.

IER—IRQ Enable Register

H'F5 Interrupt controller

ISR—IRQ Status Register

H'F6 Interrupt controller

Bit	7	6	5	4	3	2	1	0
	IPRA7	IPRA6	IPRA5	IPRA4	IPRA3	IPRA2	IPRA1	IPRA0
Initial value	0	0	0	0	0	0	0	0
Read/Write	R/W	R/W	R/W	R/W	R/W	R/W	R/W	R/W

Priority level A7 to A0

0	Priority level 0 (low priority)
1	Priority level 1 (high priority)

Bit	7	6	5	4	3	2	1	0
	IPRB7	IPRB6	—	—	IPRB3	—	IPRB1	—
Initial value	0	0	0	0	0	0	0	0
Read/Write	R/W	R/W	R/W	R/W	R/W	R/W	R/W	R/W

Priority level B7, B6, B3, and B1

0	Priority level 0 (low priority)
1	Priority level 1 (high priority)

Appendix C I/O Port Block Diagrams

C.1 Port 6 Block Diagram

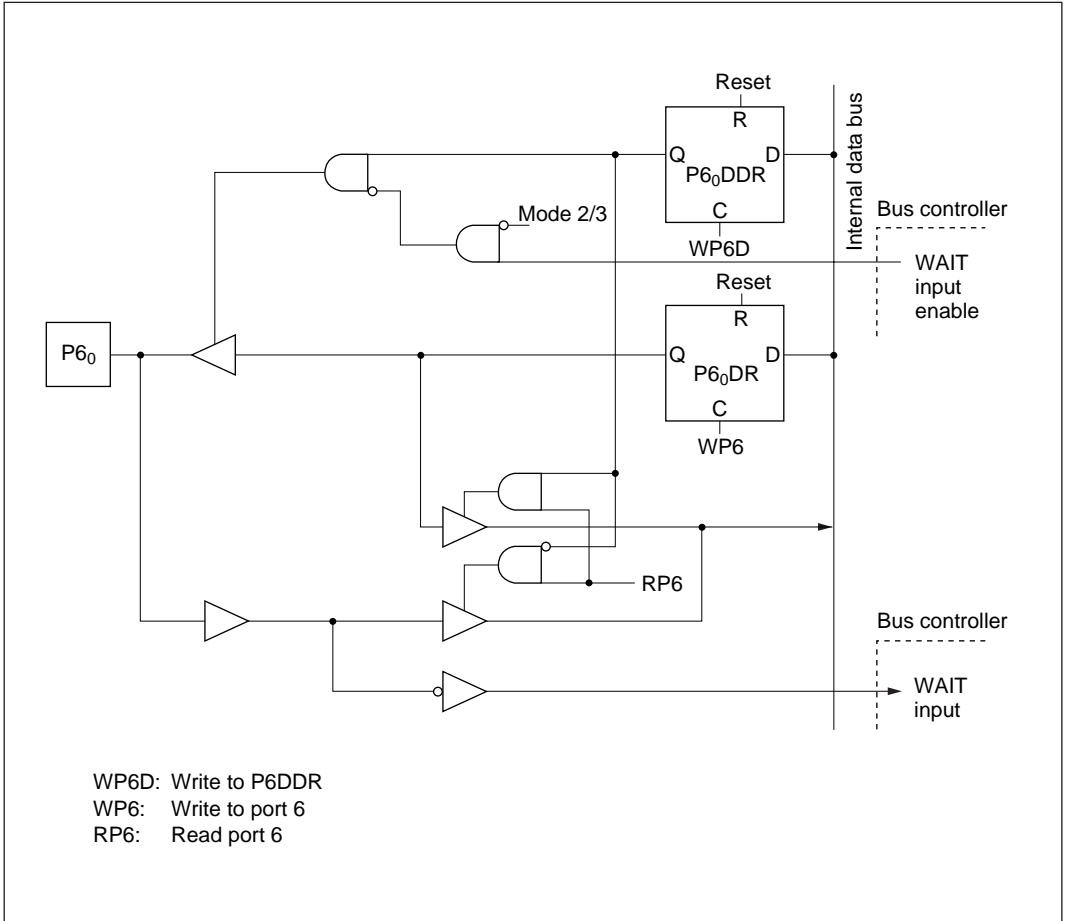

Figure C-1 Port 6 Block Diagram (Pin P6₀)

C.2 Port 7 Block Diagram

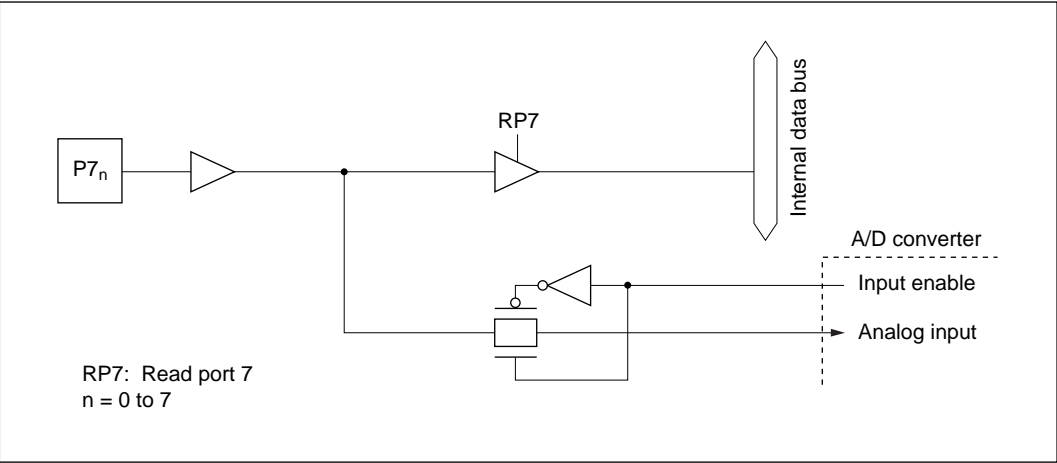

Figure C-2 Port 7 Block Diagram

C.3 Port 8 Block Diagram

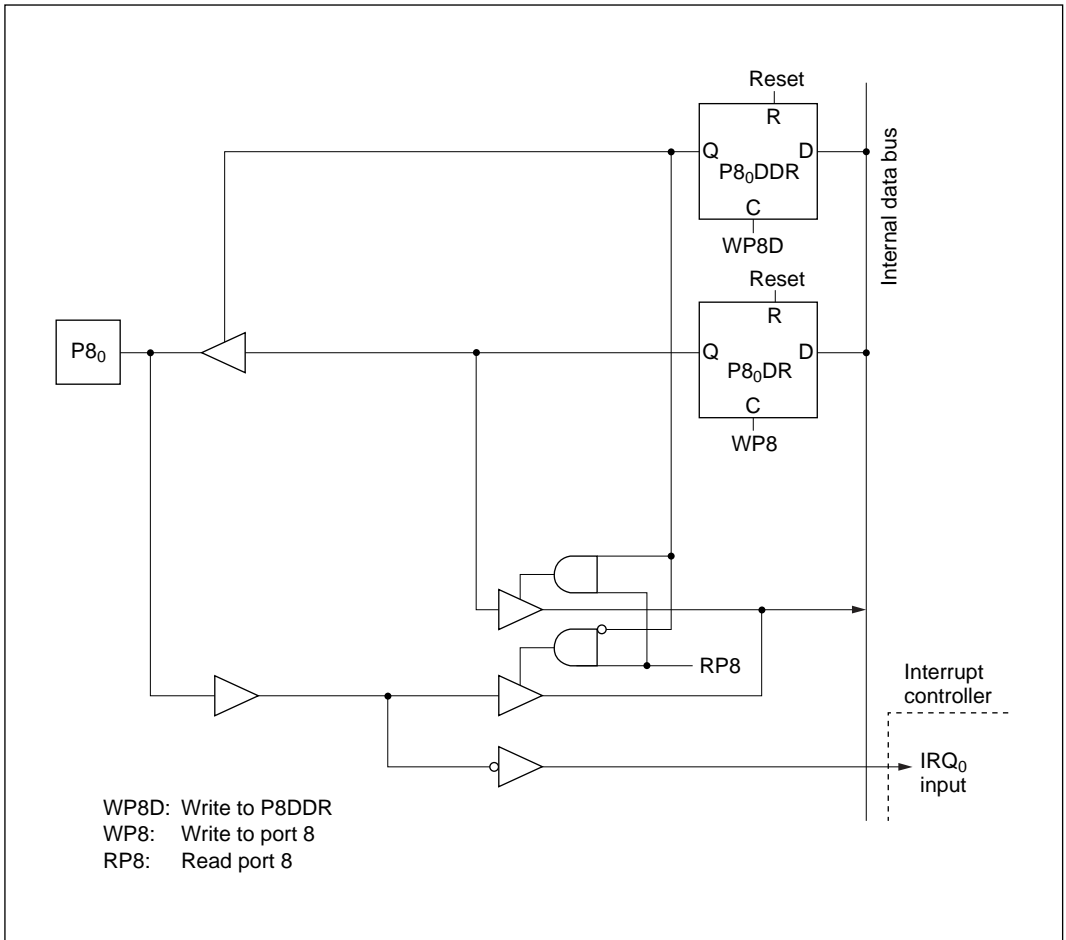

Figure C-3 (a) Port 8 Block Diagram (Pin P8₀)

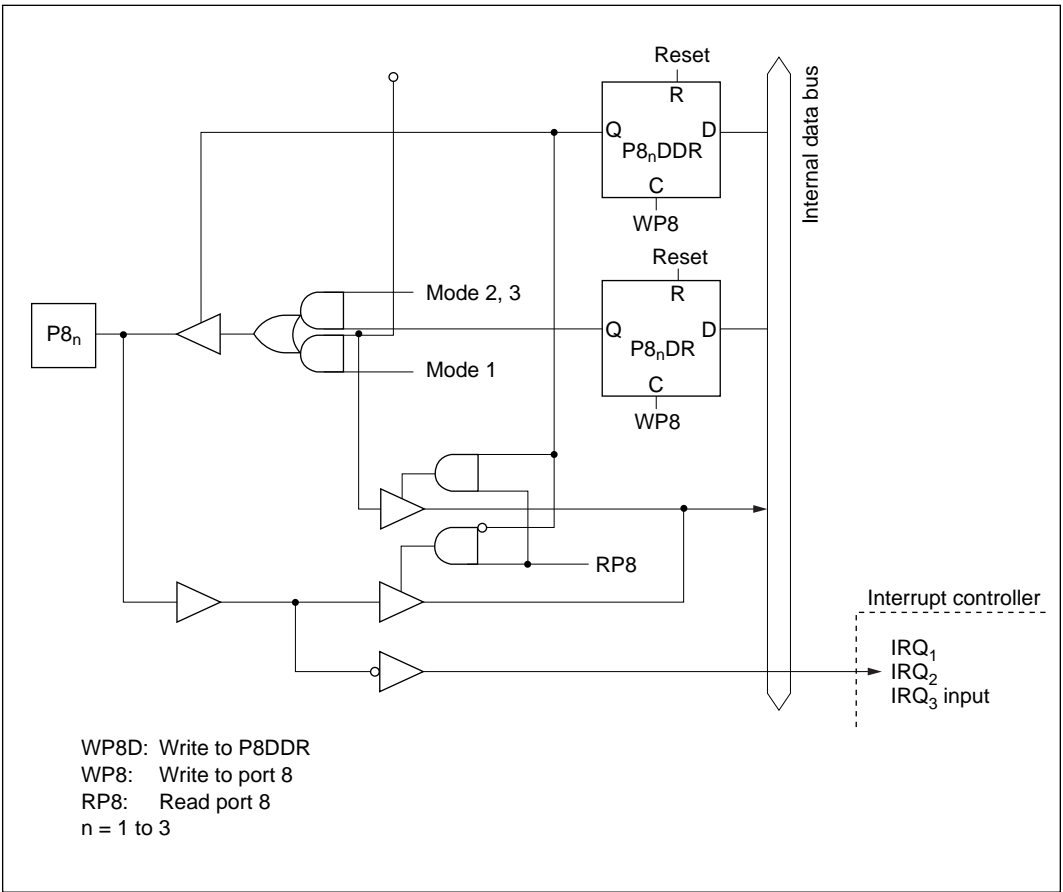

Figure C-3 (b) Port 8 Block Diagram (Pin $P8_1$, $P8_2$, $P8_3$)

C.4 Port 9 Block Diagram

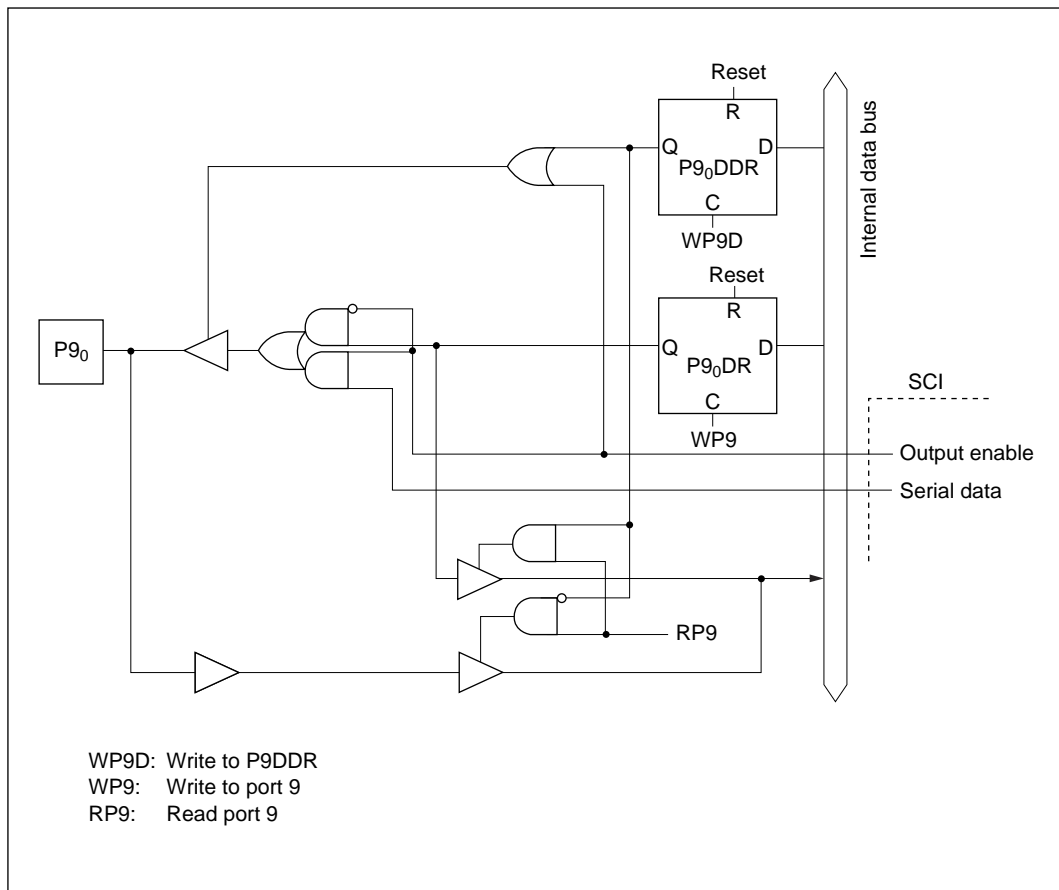

Figure C-4 (a) Port 9 Block Diagram (Pin P9₀)

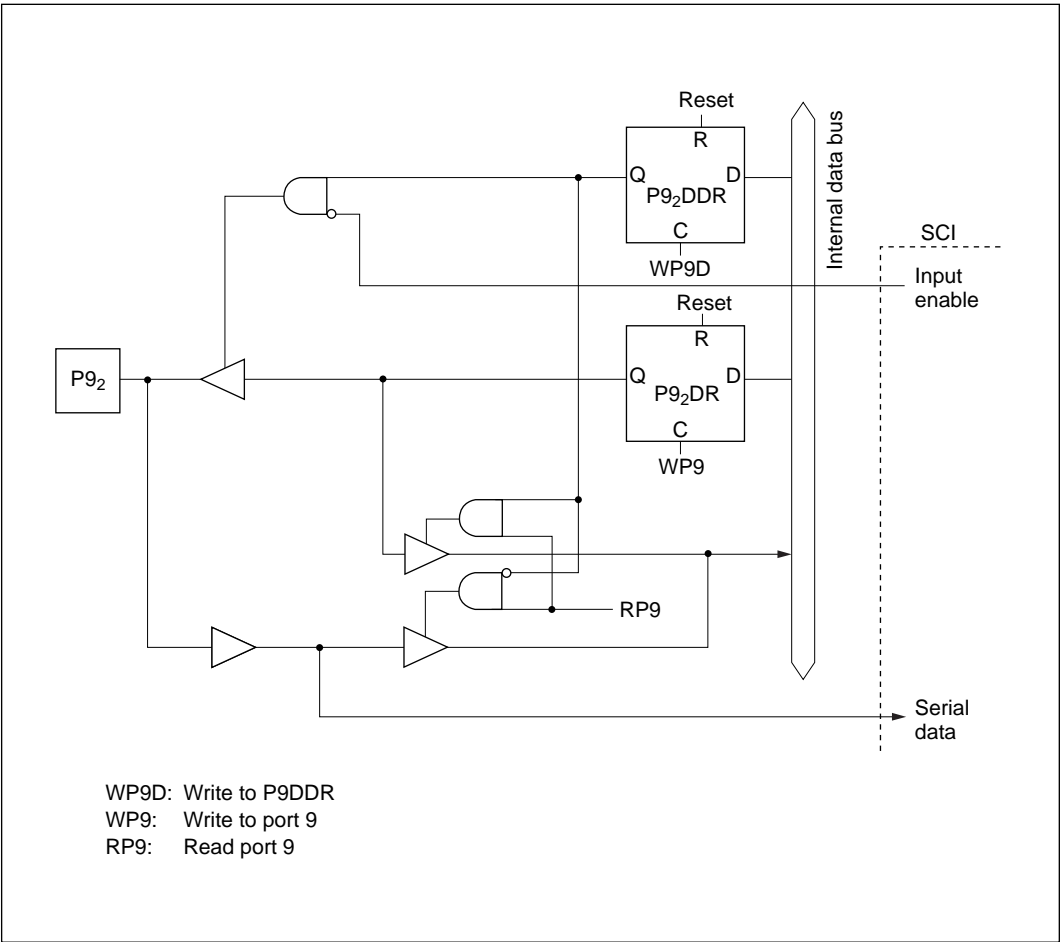

Figure C-4 (b) Port 9 Block Diagram (Pins P9₂)

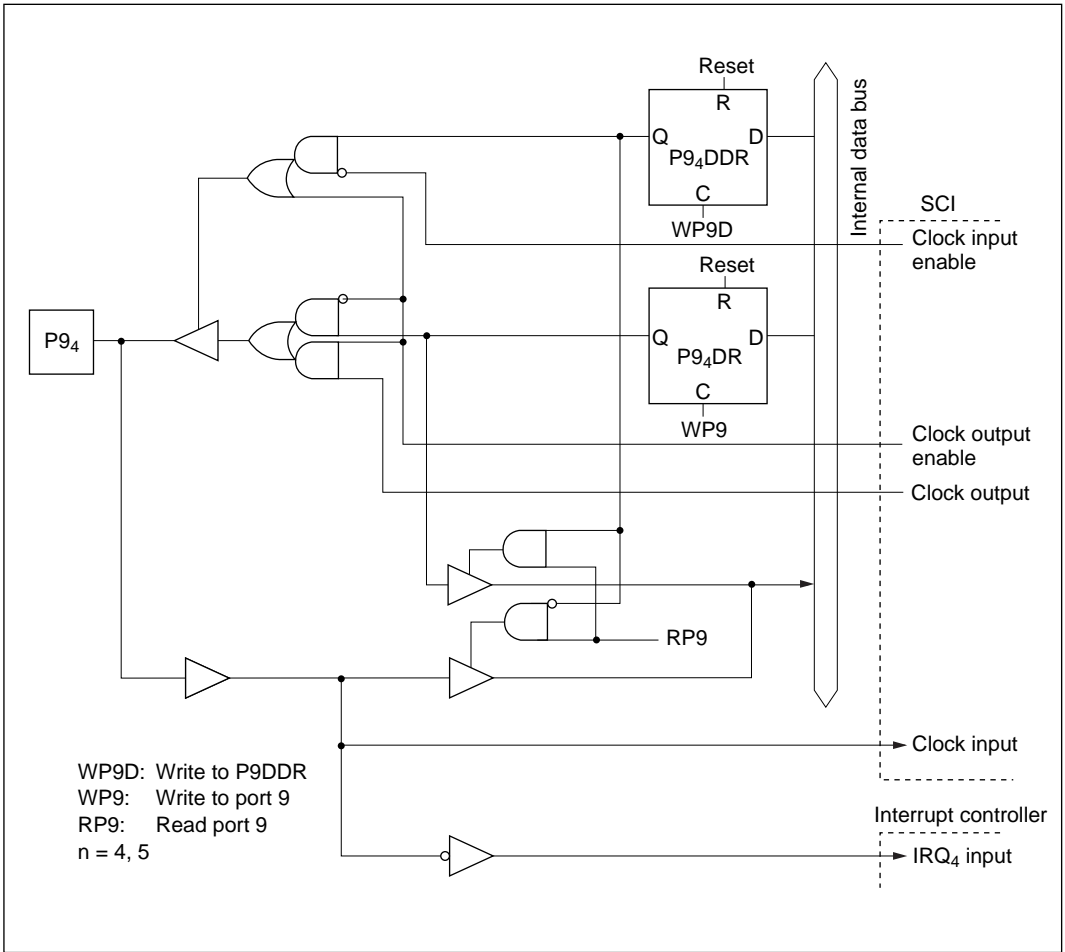

Figure C-4 (c) Port 9 Block Diagram (Pin P9₄)

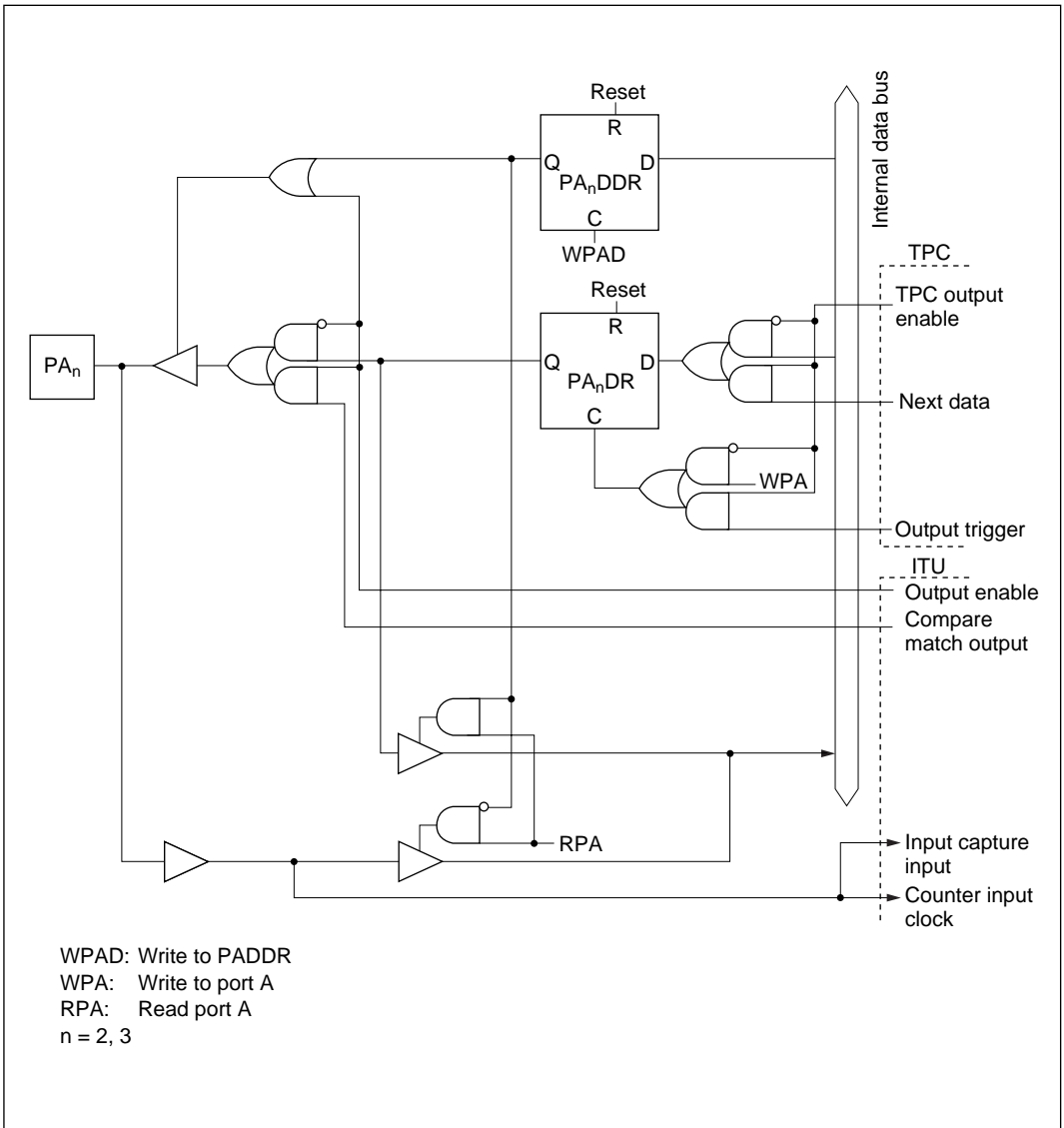

Figure C-5 (b) Port A Block Diagram (Pins PA₂, PA₃)

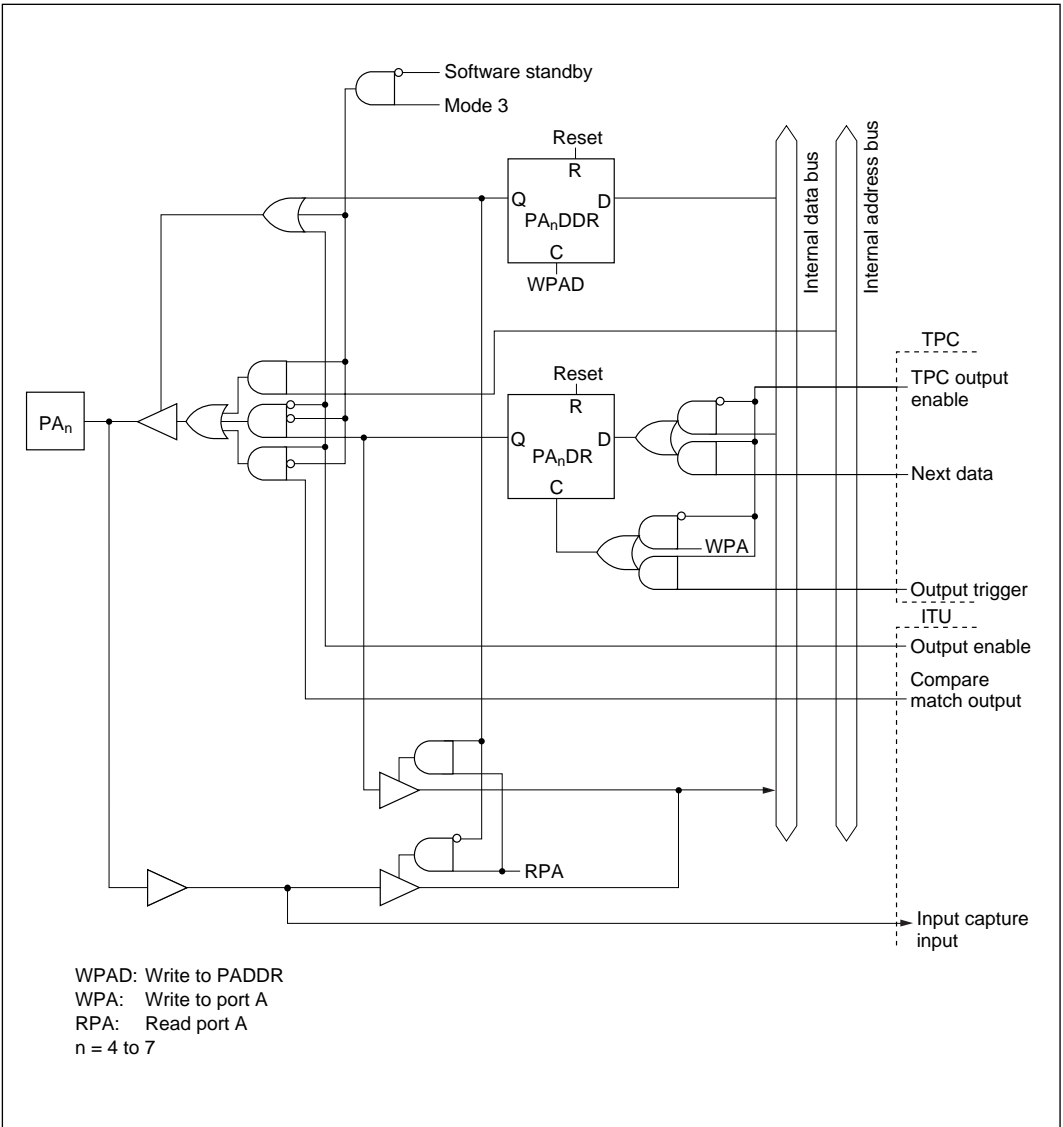

Figure C-5 (c) Port A Block Diagram (Pins PA₄ to PA₇)

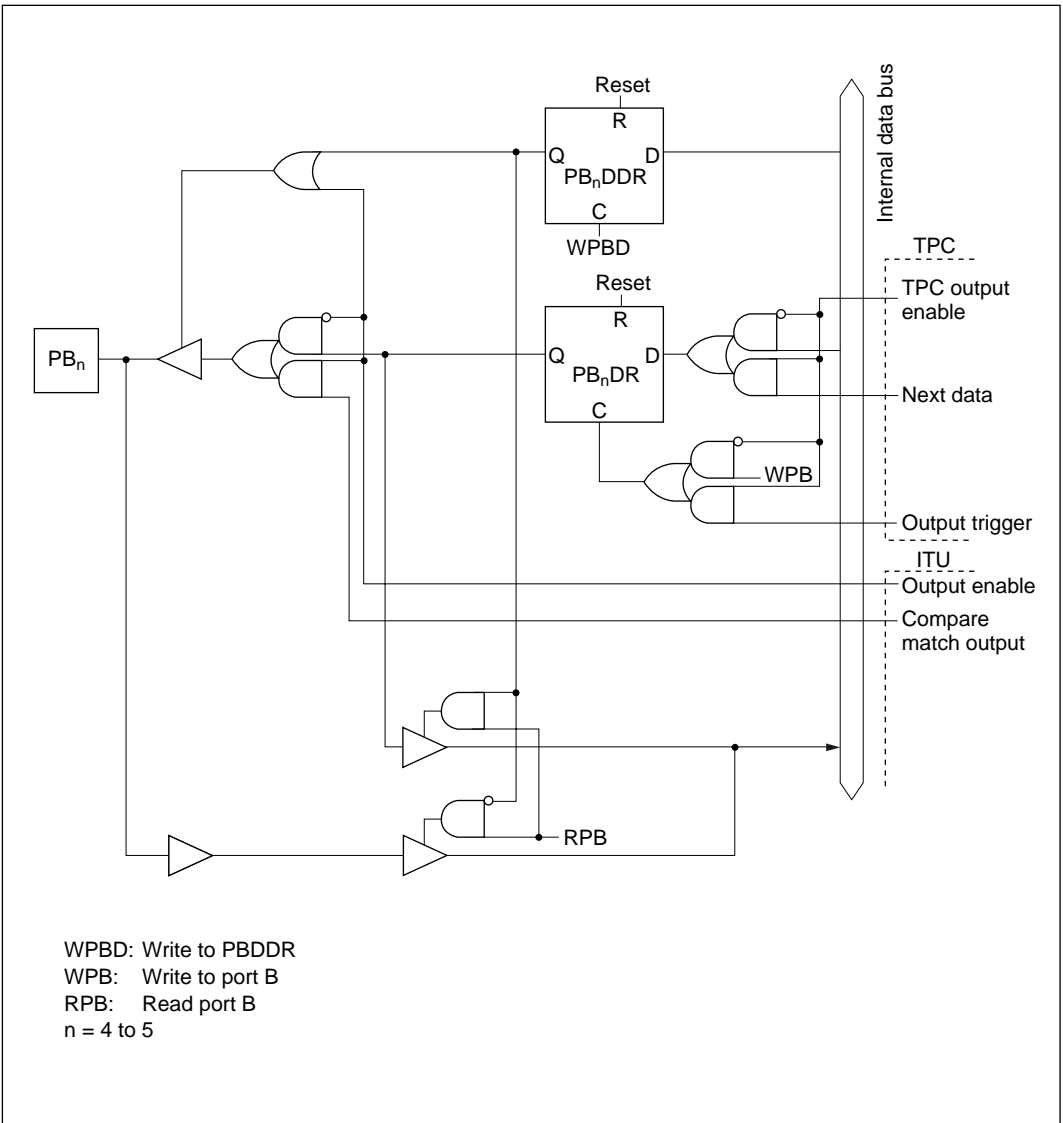

Figure C-6 (b) Port B Block Diagram (Pins PB₄, PB₅)

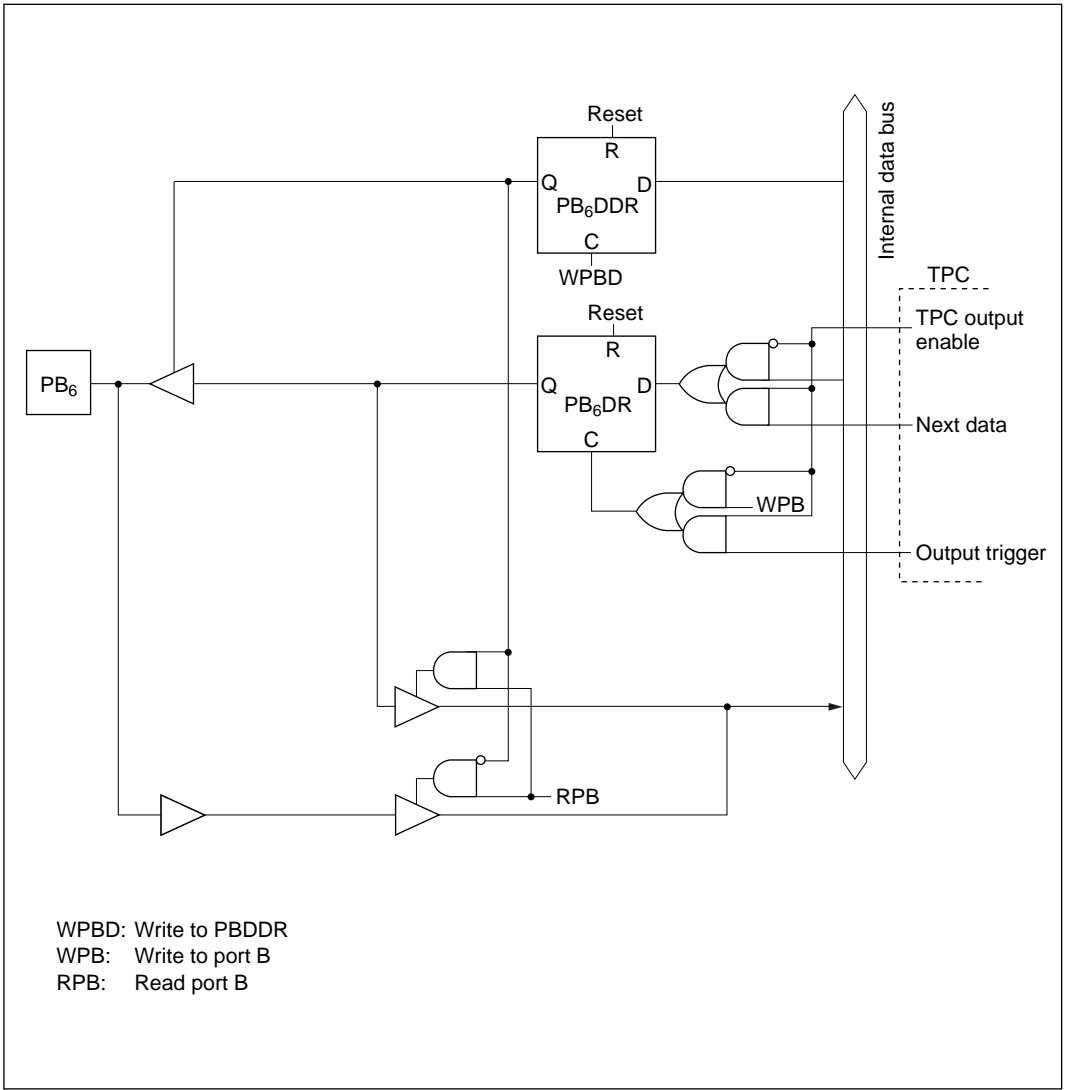

Figure C-6 (c) Port B Block Diagram (Pin PB₆)

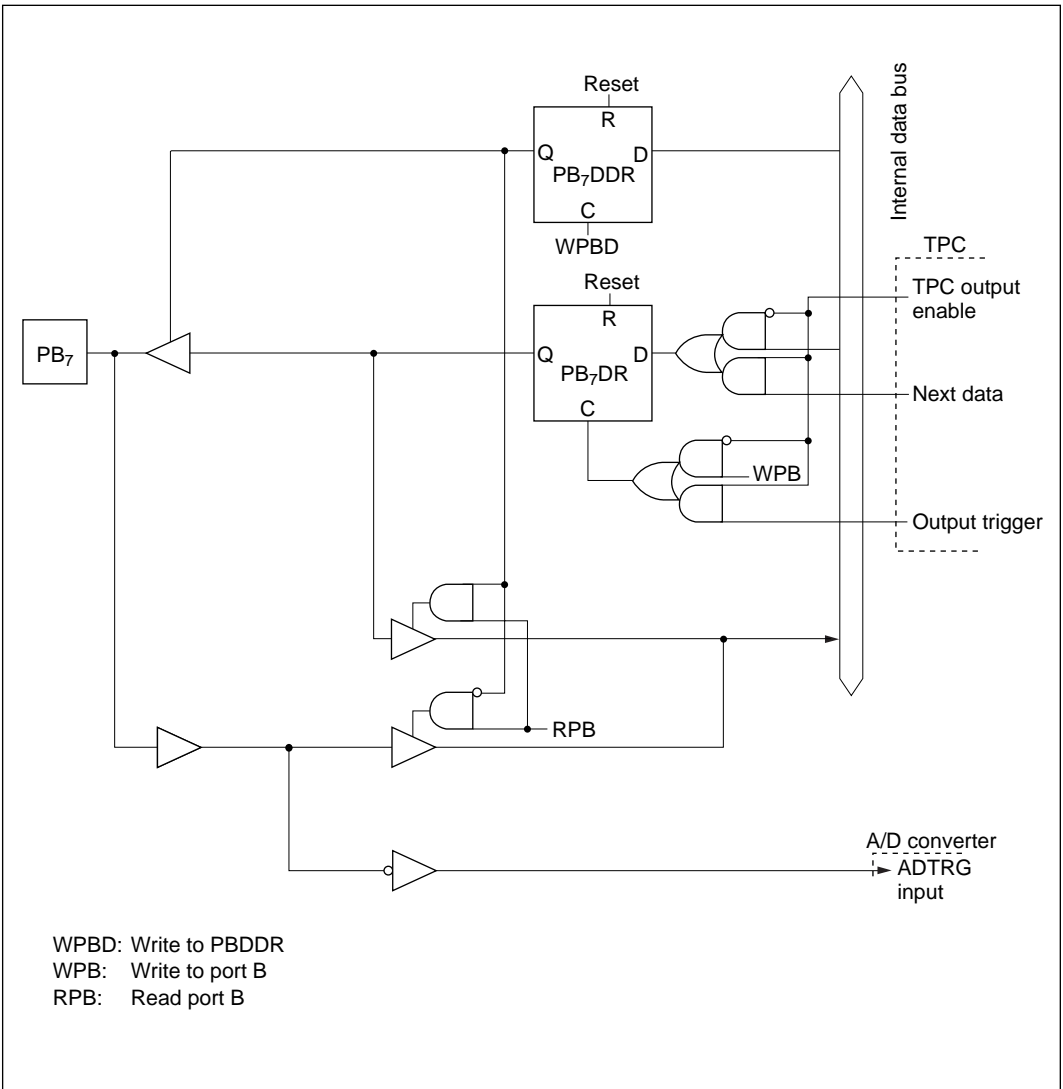

Figure C-6 (d) Port B Block Diagram (Pin PB₇)

Appendix D Pin States

D.1 Port States in Each Mode

Table D-1 Port States

Pin Name	Mode	Reset State	Hardware Standby Mode	Software Standby Mode	Sleep Mode	Program Execution Sleep Mode	
∅	—	Clock output	T	H	Clock output	Clock output	
$\overline{\text{RESO}}$	—	T*1	T	T	T	$\overline{\text{RESO}}$	
P6 ₀	1, 3	$\overline{\text{WAIT}}$ pin	—	—	T	T	$\overline{\text{WAIT}}$
		Generic I/O pin	T	T	T	T	I/O port
P7 ₇ to P7 ₀	1, 3	T	T	T	T	Input port	
P8 ₃ to P8 ₀	1, 3	T	T	keep	keep	I/O port	
P9 ₄ , P9 ₂ , P9 ₀	1, 3	T	T	keep	keep	I/O port	
PA ₃ to PA ₀	1, 3	T	T	keep	keep	I/O port	
PA ₇ to PA ₄	1	T	T	keep	keep	I/O port	
	3	T	T	I/O port*2	A ₂₀ to A ₂₃	A ₂₀ to A ₂₃	
PB ₇ to PB ₀	1, 3	T	T	keep	keep	I/O port	

Legend

H: High

L: Low

T: High-impedance state

keep: Input pins are in the high-impedance state; output pins maintain their previous state.

DDR: Data direction register bit

Notes: 1. A low level is output only in the case of a reset due to WDT overflow.

2. The pin states at this time depend on the DDR setting.

D.2 Pin States at Reset

Reset in T_1 State: Figure D-1 is a timing diagram for the case in which $\overline{\text{RES}}$ goes low during the T_1 state of an external memory access cycle. As soon as $\overline{\text{RES}}$ goes low, all ports are initialized to the input state. $\overline{\text{AS}}$, $\overline{\text{RD}}$, and $\overline{\text{WR}}$ go high, and the data bus goes to the high-impedance state. The address bus is initialized to the low output level 0.5 state after the low level of $\overline{\text{RES}}$ is sampled. Sampling of $\overline{\text{RES}}$ takes place at the fall of the system clock (ϕ).

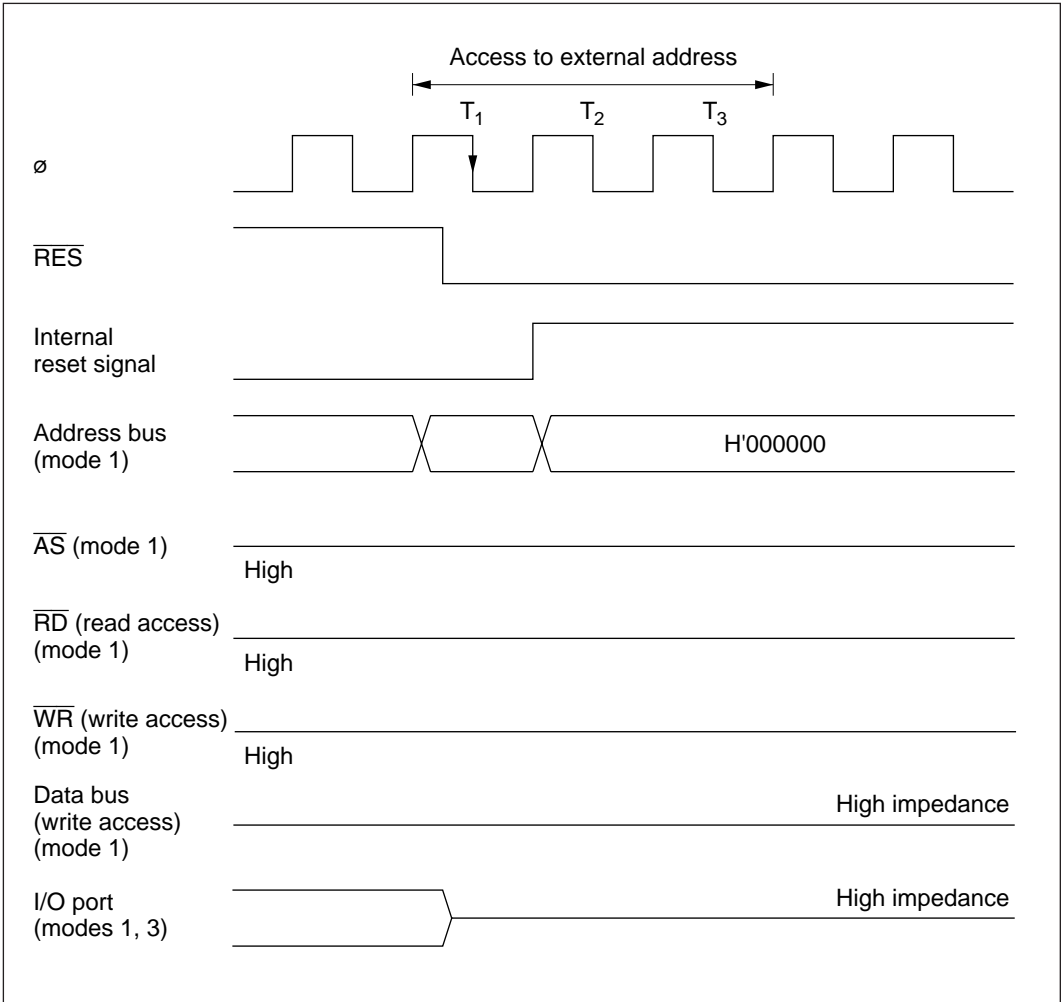

Figure D-1 Reset during Memory Access (Reset during T_1 State)

Reset in T_2 State: Figure D-2 is a timing diagram for the case in which $\overline{\text{RES}}$ goes low during the T_2 state of an external memory access cycle. As soon as $\overline{\text{RES}}$ goes low, all ports are initialized to the input state. $\overline{\text{AS}}$, $\overline{\text{RD}}$, and $\overline{\text{WR}}$ go high, and the data bus goes to the high-impedance state. The address bus is initialized to the low output level 0.5 state after the low level of $\overline{\text{RES}}$ is sampled. The same timing applies when a reset occurs during a wait state (T_W).

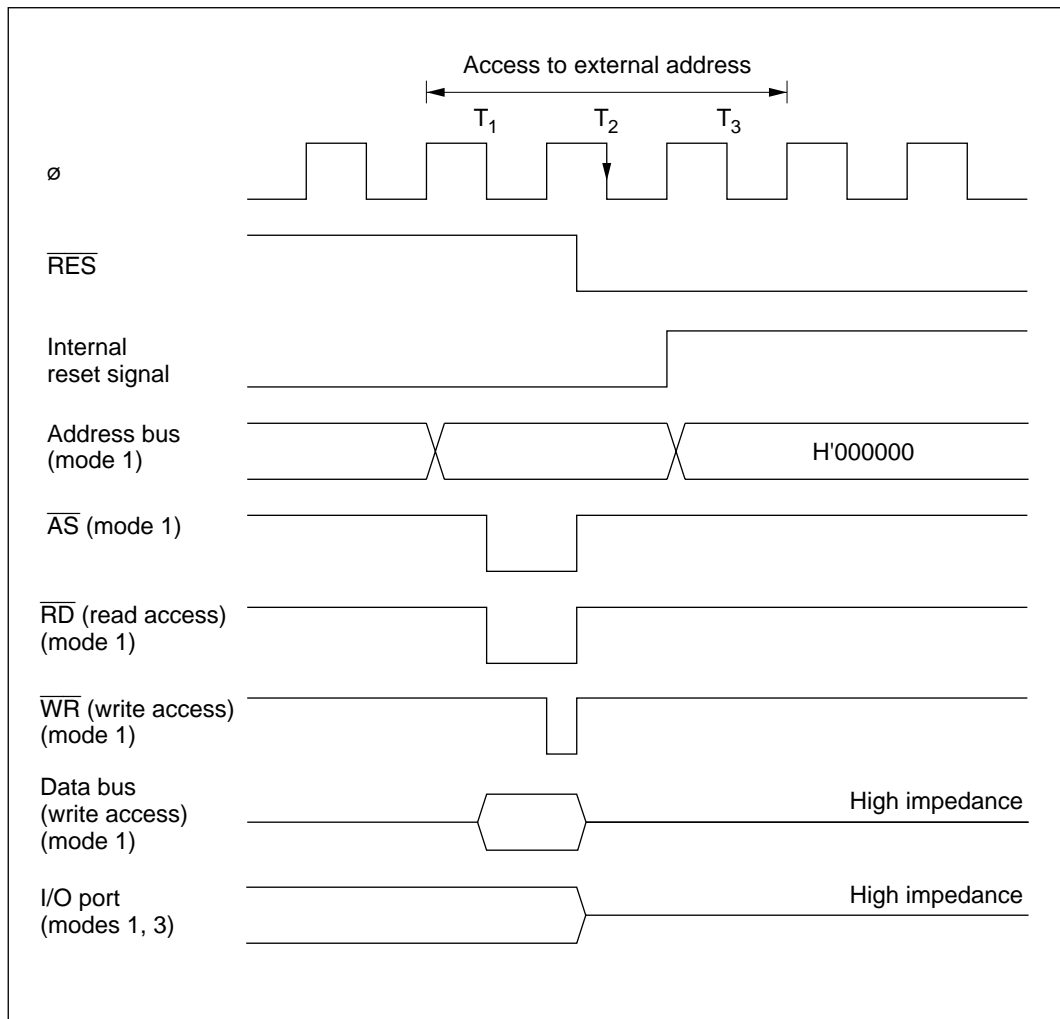

Figure D-2 Reset during Memory Access (Reset during T_2 State)

Reset in T₃ State: Figure D-3 is a timing diagram for the case in which $\overline{\text{RES}}$ goes low during the T₃ state of an external memory access cycle. As soon as $\overline{\text{RES}}$ goes low, all ports are initialized to the input state. $\overline{\text{AS}}$, $\overline{\text{RD}}$, and $\overline{\text{WR}}$ go high, and the data bus goes to the high-impedance state. The address bus outputs are held during the T₃ state. The same timing applies when a reset occurs in the T₂ state of an access cycle to a two-state-access area.

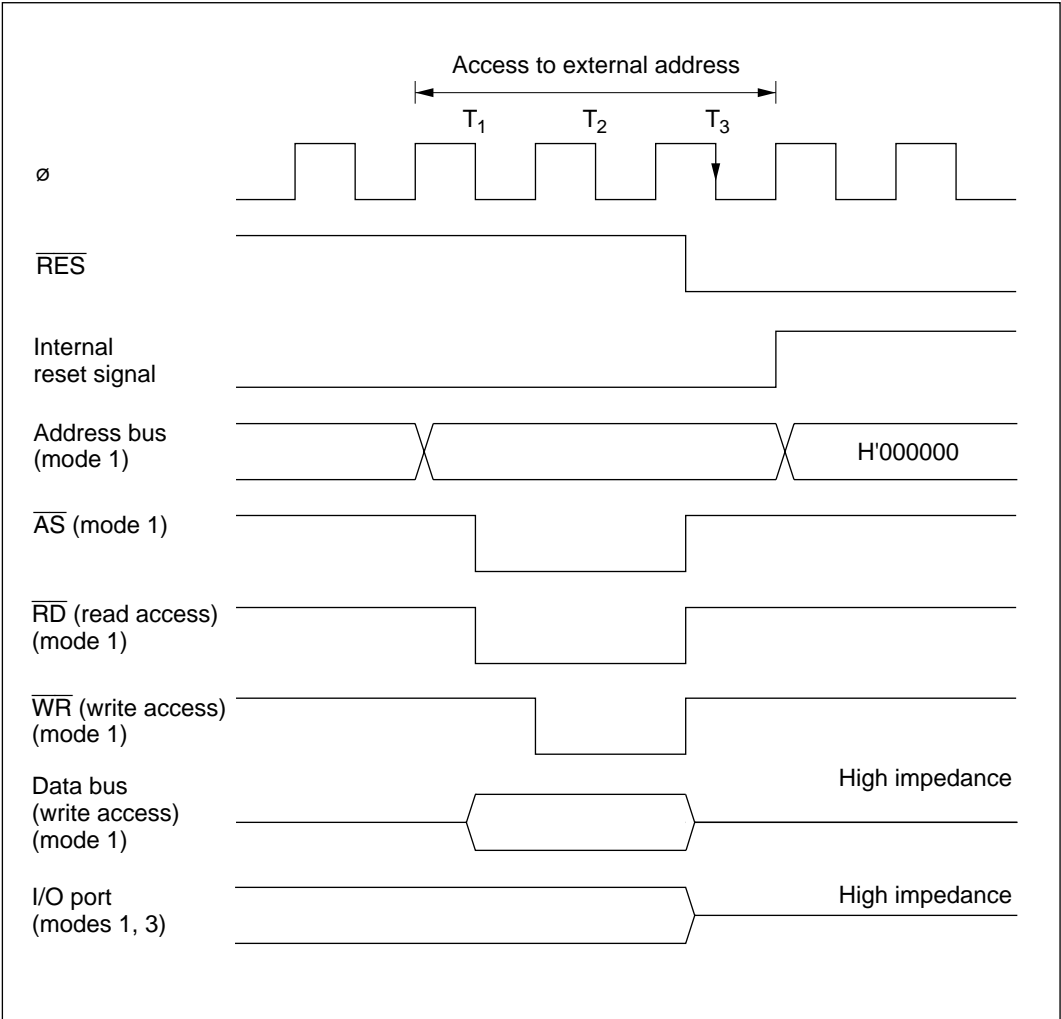
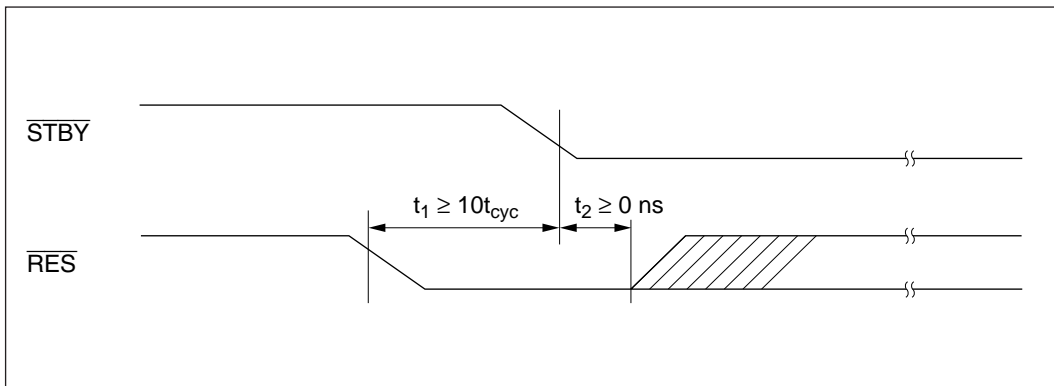

Figure D-3 Reset during Memory Access (Reset during T₃ State)

Appendix E Timing of Transition to and Recovery from Hardware Standby Mode

Timing of Transition to Hardware Standby Mode

- (1) To retain RAM contents with the RAME bit set to 1 in SYSCR, drive the $\overline{\text{RES}}$ signal low 10 system clock cycles before the $\overline{\text{STBY}}$ signal goes low, as shown below. $\overline{\text{RES}}$ must remain low until $\overline{\text{STBY}}$ goes low (minimum delay from $\overline{\text{STBY}}$ low to $\overline{\text{RES}}$ high: 0 ns).



- (2) To retain RAM contents with the RAME bit cleared to 0 in SYSCR, $\overline{\text{RES}}$ does not have to be driven low as in (1).

Timing of Recovery from Hardware Standby Mode: Drive the $\overline{\text{RES}}$ signal low approximately 100 ns before $\overline{\text{STBY}}$ goes high.

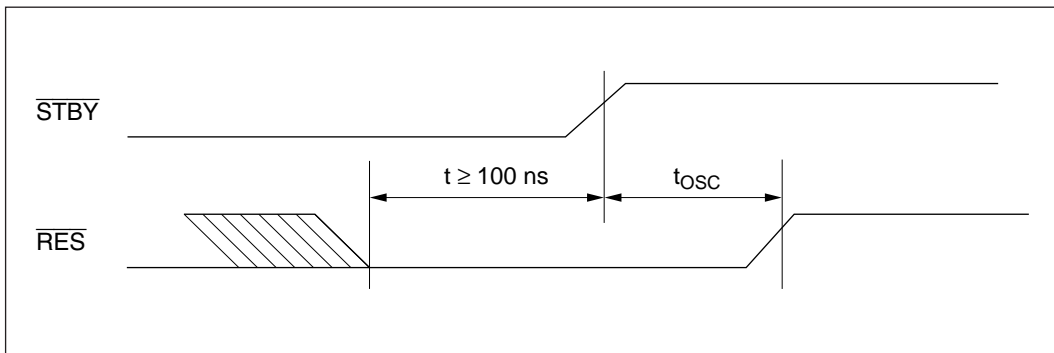

Appendix F Product Code Lineup

Table F H8/3004 and H8/3005 Series Product Code Lineup

Product Type		Product Code	Mark Code	Order Code Name	Package (Hitachi Package Code)	
H8/3004	ROM less version	Standard products	HD6413004F	HD6413004F	HD6413004F	80-pin QFP (FP-80A)
		I specification	HD6413004TEi	HD6413004TEi	HD6413004Xi	80-pin TQFP (TFP-80C)
H8/3005	ROM less version	Standard products	HD6413005F	HD6413005F	HD6413005F	80-pin QFP (FP-80A)
		I specification	HD6413005TEi	HD6413005TEi	HD6413005Xi	80-pin TQFP (TFP-80C)

Appendix G Package Dimensions

Figure G-1 shows the FP-80A package dimensions of the H8/3004 and H8/3005, and figure G-2 shows the TFP-80C package dimensions.

Unit: mm

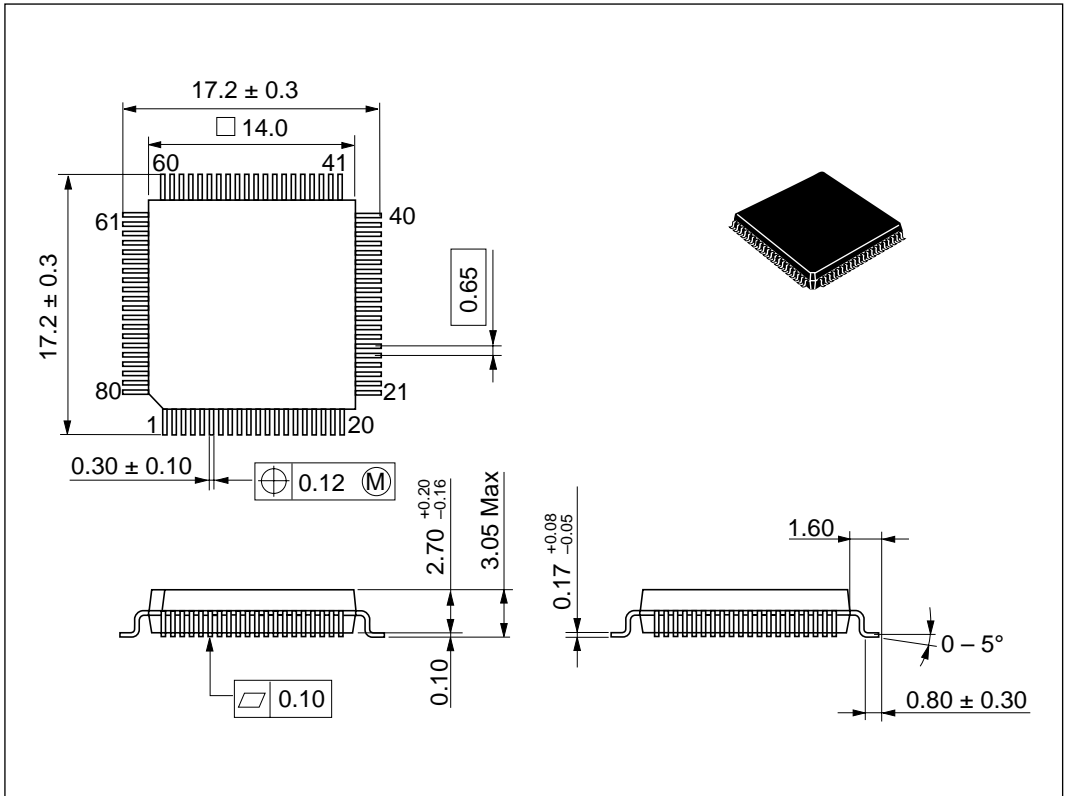

Figure G-1 Package Dimensions (FP-80A)

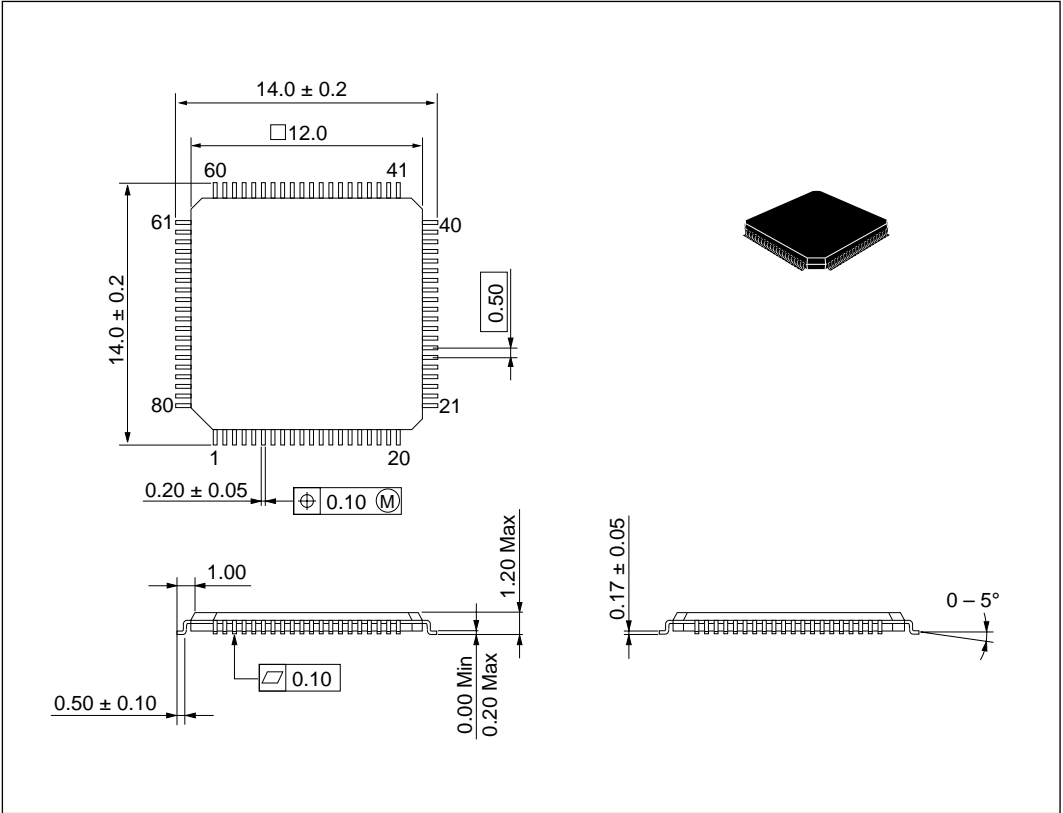

Figure G-2 Package Dimensions (TFP-80C)

Hitachi Microcomputer H8/3004, 3005

Publication Date: 1st Edition, September 1995

Published by: Semiconductor and IC Div.
Hitachi, Ltd.

Edited by: Technical Document Center
Hitachi Microcomputer System Ltd.

Copyright © Hitachi, Ltd., 1995. All rights reserved. Printed in Japan.