

TOSHIBA BIPOLAR LINEAR INTEGRATED CIRCUIT SILICON MONOLITHIC

TA2050S, TA2050F

GROUND ISOLATOR IC

TA2050S/F are ground isolator IC designed for car audio equipments.

These IC contains dual channel differential amplifier with built-in feedback resistors.

The effect of ground noise due to difference grounding points on car chassis between head unit and other component unit can be reduced by high common mode rejection performance.

Non-inverting and inverting application are available.

FEATURES

- Dual Channel Differential Amplifier
- Built-in feedback Resistor
- High Common Mode Rejection Ratio
 - : CMRR = 60dB (Typ.) ($V_{CC} = 8V$, $f = 1kHz$, $V_{CM} = 1V_{rms}$)
- Low Noise
 - : $V_{NO} = 1.7\mu V_{rms}$ (Typ.)
 - ($V_{CC} = 8V$, $R_g = 620\Omega$, Filter = 20Hz~20kHz)
- Low Distortion
 - : THD = 0.002% (Typ.) ($V_{CC} = 8V$, $f = 1kHz$, $V_{IN} = 1V_{rms}$)
- Package
 - : TA2050S Single-Inline 9pins (SIP-9)
 - TA2050F 1mm pitch Flat package 16pins (MFP-16)
- Operating Supply Voltage Range
 - : $V_{CC(opr)} = 5\sim 10V$ ($T_a = 25^\circ C$)

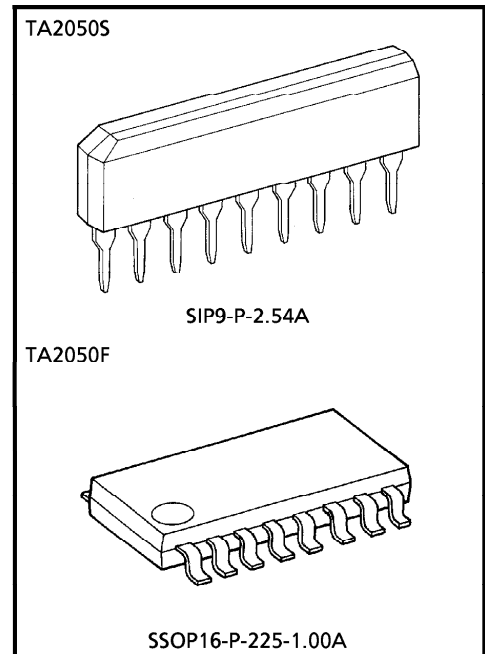

Weight
 SIP9-P-2.54A : 0.92g (Typ.)
 SSOP16-P-225-1.00A : 0.14g (Typ.)

961001EBA1

- TOSHIBA is continually working to improve the quality and the reliability of its products. Nevertheless, semiconductor devices in general can malfunction or fail due to their inherent electrical sensitivity and vulnerability to physical stress. It is the responsibility of the buyer, when utilizing TOSHIBA products, to observe standards of safety, and to avoid situations in which a malfunction or failure of a TOSHIBA product could cause loss of human life, bodily injury or damage to property. In developing your designs, please ensure that TOSHIBA products are used within specified operating ranges as set forth in the most recent products specifications. Also, please keep in mind the precautions and conditions set forth in the TOSHIBA Semiconductor Reliability Handbook.
- The products described in this document are subject to foreign exchange and foreign trade control laws.
- The information contained herein is presented only as a guide for the applications of our products. No responsibility is assumed by TOSHIBA CORPORATION for any infringements of intellectual property or other rights of the third parties which may result from its use. No license is granted by implication or otherwise under any intellectual property or other rights of TOSHIBA CORPORATION or others.
- The information contained herein is subject to change without notice.

BLOCK DIAGRAM

TA2050S

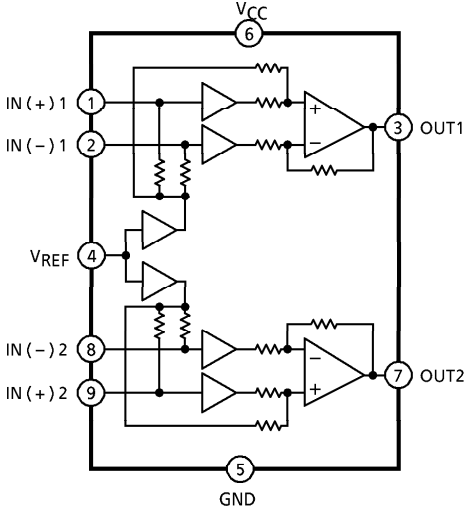

TA2050F

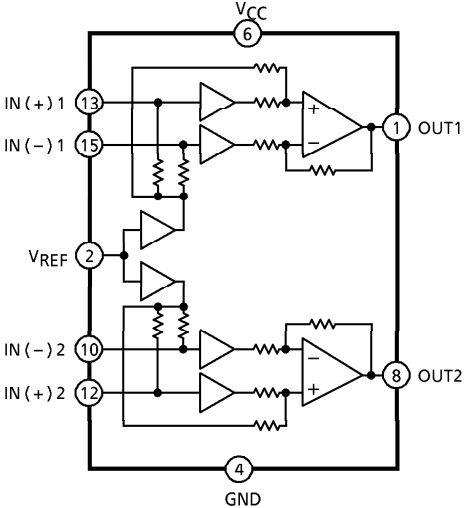

※ 3, 5, 7, 9, 11, 14, 16pin : NC

TERMINAL EXPLANATION

TERMINAL NAME		SYMBOL	CONTENTS	EQUIVALENT CIRCUIT
S	F			
1	13	IN (+) 1	Noninverting input terminal for channel 1. This terminal is biased by resistor (100kΩ (Typ.)) from internal reference amplifier.	
2	15	IN (-) 1	Inverting line input terminal for channel 1. This terminal is biased by resistor (100kΩ (Typ.)) from internal reference amplifier.	
3	1	OUT1	Channel 1 output terminal. Output resistor is 100Ω (Typ.).	
4	2	VREF	Reference voltage terminal. Individual built-in reference amp for each channel.	
5	4	GND	—	—
6	6	VCC	—	—
7	8	OUT2	Channel 2 output terminal. Output resistor is 100Ω (Typ.).	Same as OUT1
8	10	IN (-) 2	Channel 2 output terminal. Output resistor is 100Ω (Typ.).	Same as IN (+) 1, IN (-) 1
9	12	IN (+) 2	Channel 2 output terminal. Output resistor is 100Ω (Typ.).	
—	3 5 7 9 11 14 16	N.C	Non. connection terminal for TA2050F.	—

MAXIMUM RATINGS (Ta = 25°C)

CHARACTERISTIC	SYMBOL	RATING	UNIT
Supply Voltage	V _{CC}	15	V
Power Dissipation	TA2050S	900	mW
	TA2050F	350	
Operating Temperature	T _{opr}	-30~85	°C
Storage Temperature	T _{stg}	-55~150	°C

(Note) Derated above Ta = 25°C in the proportion of 7.2mW/°C for TA2050S, 2.8mW /°C for TA2050F.

ELECTRICAL CHARACTERISTICS

(Unless otherwise specified, V_{CC} = 8V, f = 1kHz, R_L = 10kΩ, noninverting configuration, Ta = 25°C)

CHARACTERISTIC	SYMBOL	TEST CIRCUIT	TEST CONDITION	MIN.	TYP.	MAX.	UNIT
Quiescent Current	I _{CCQ}	—	V _{in} = 0	6	9	15	mA
Voltage Gain	G _V	—	—	-1	0	+1	dB
Maximum Output Voltage	V _{OM} (1)	—	Noninverting, THD = 1%	1.3	1.7	—	V _{rms}
	V _{OM} (2)	—	Inverting, THD = 1%	1.0	1.2	—	
Total Harmonic Distortion	THD	—	V _{out} = 1V _{rms} Filter BW = 400Hz~30kHz	—	0.002	0.01	%
Cross Talk	C.T.	—	V _{in} = 1V _{rms}	—	-86	-75	dB
Input Resistance	R _{IN}	—	—	—	100	—	kΩ
Output Resistance	R _{OUT}	—	—	—	100	—	Ω
Output Noise Voltage	V _{NO}	—	R _g = 620Ω DIN AUDIO Weighting	—	1.7	3.0	μV _{rms}
Common Mode Rejection Ratio	CMRR	—	—	—	-60	-50	dB
Maximum Common mode Input Voltage	V _{CM} (MAX)	—	CMRR = -50dB	1.0	1.6	—	V _{rms}
Ripple Rejection Ratio	R.R.	—	f = 100Hz	—	-57	-50	dB

TEST CIRCUIT

TA2050S non-inverting circuit

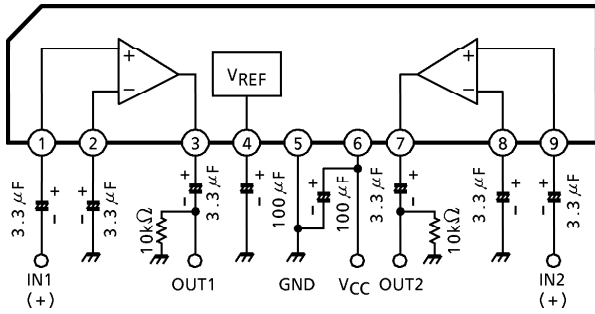

TA2050S inverting circuit

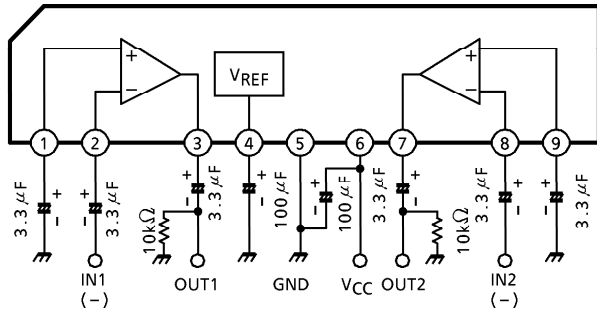

TA2050F non-inverting circuit

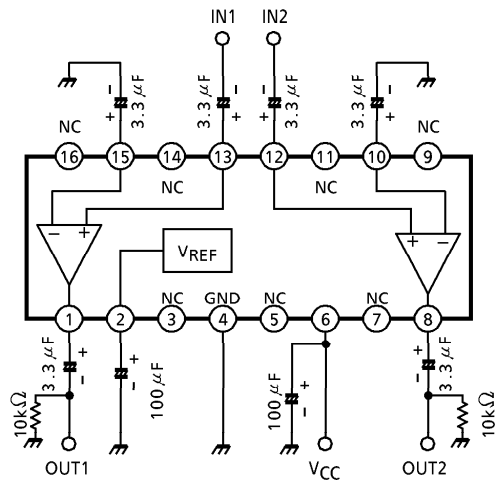

TA2050F inverting circuit

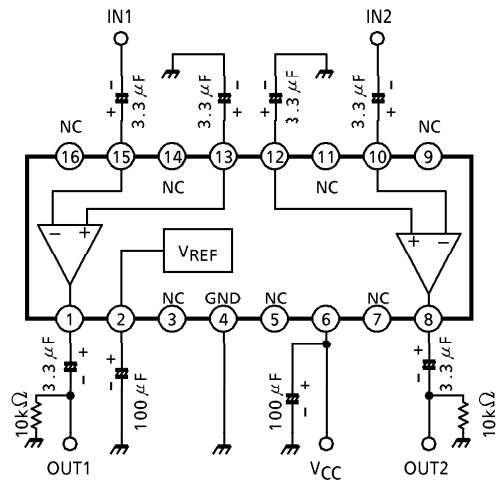

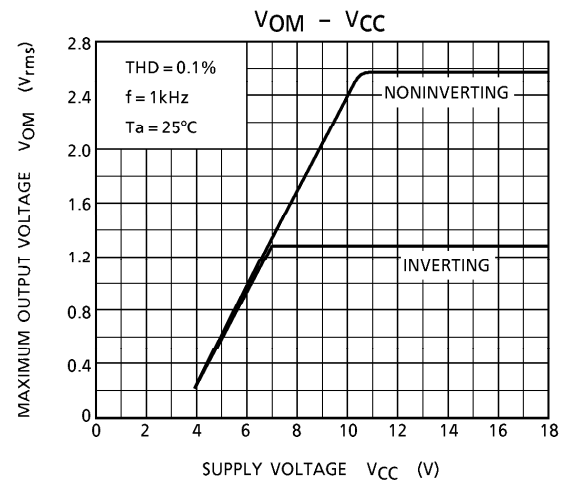
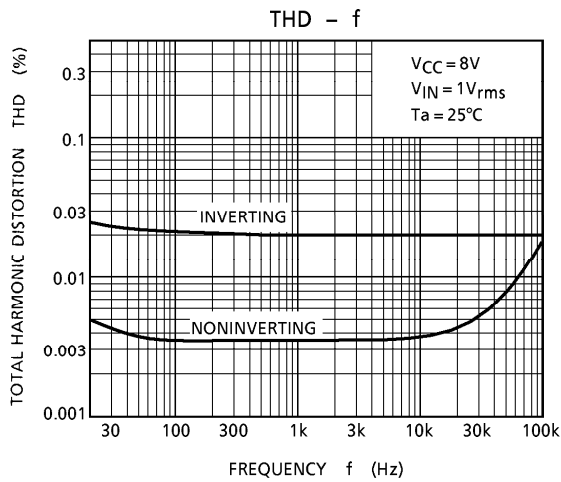
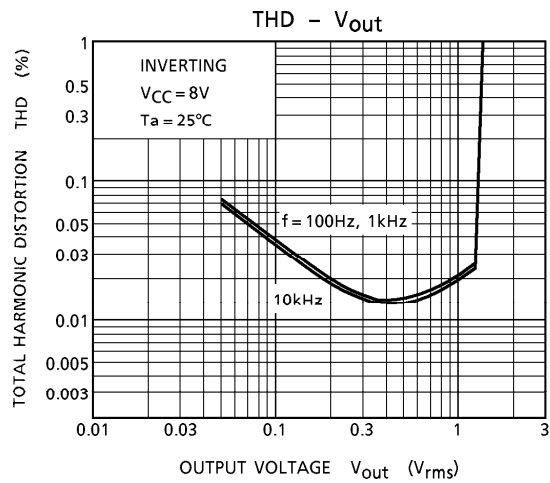
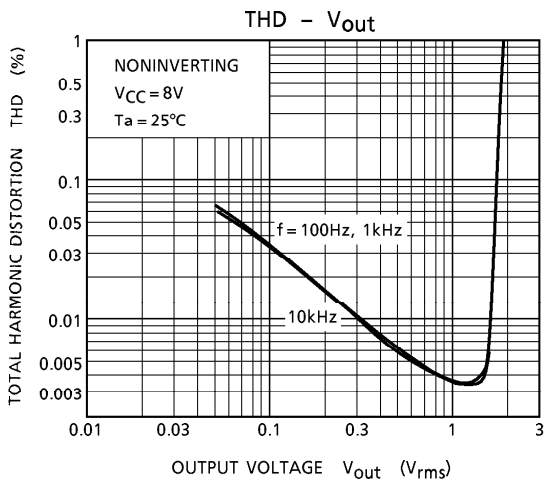
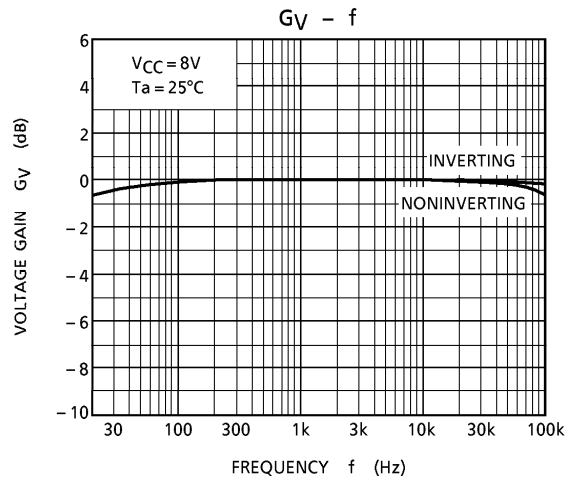
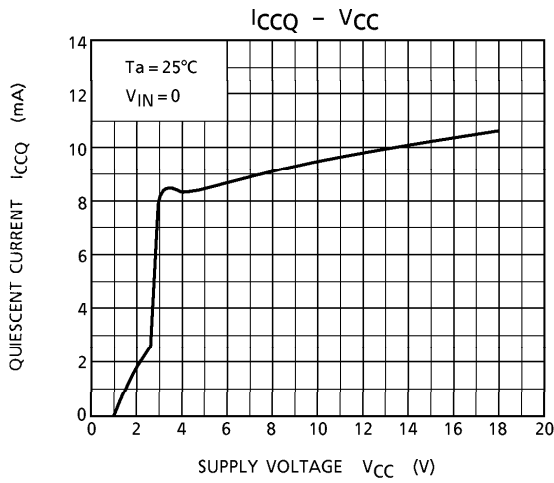

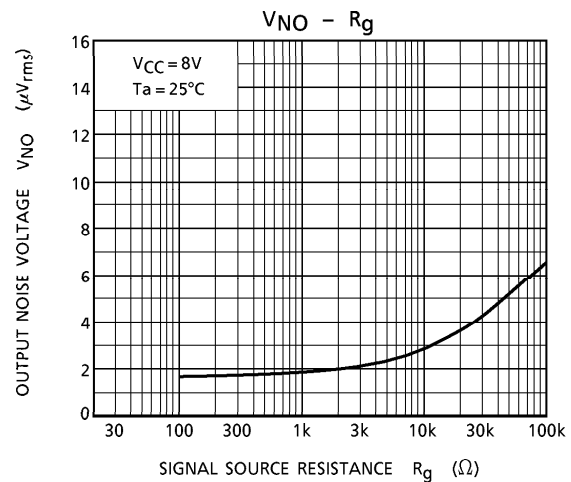
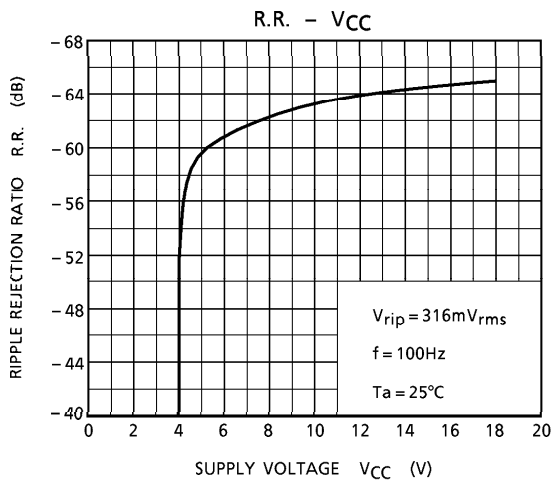
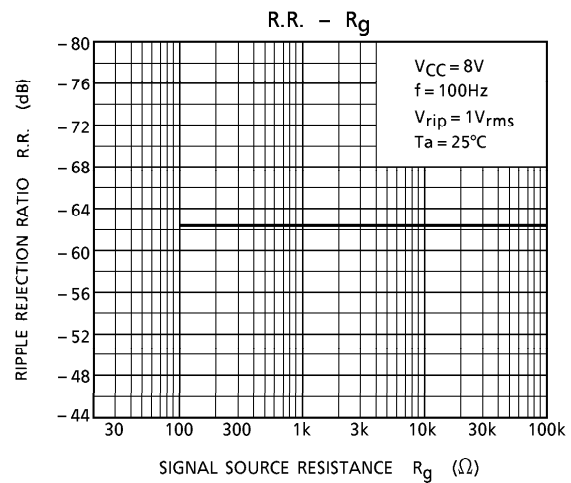
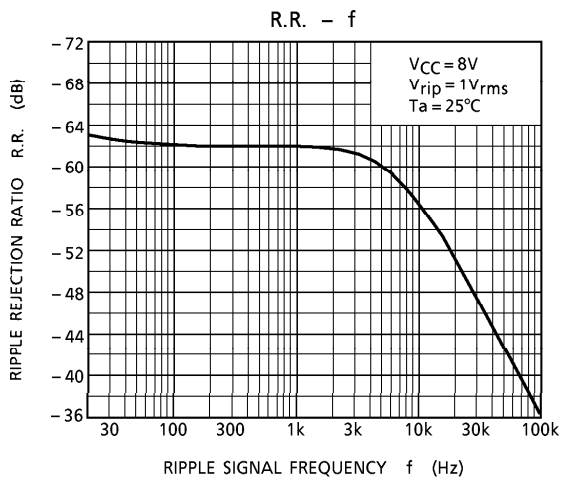
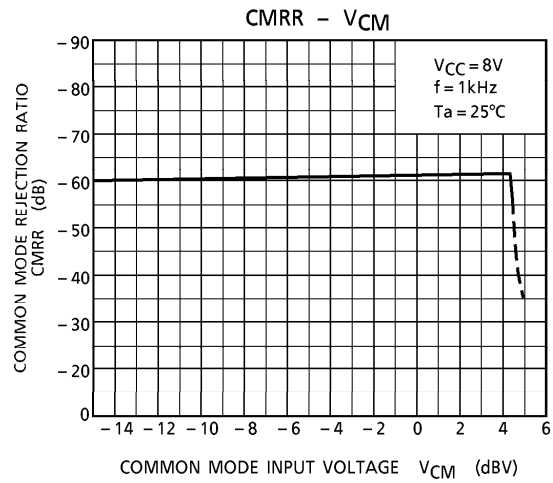
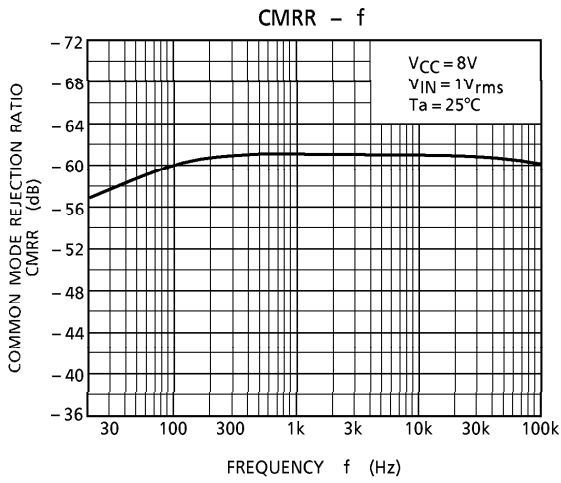

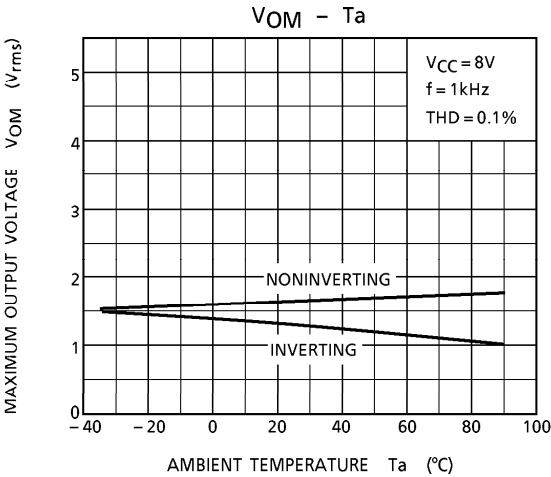
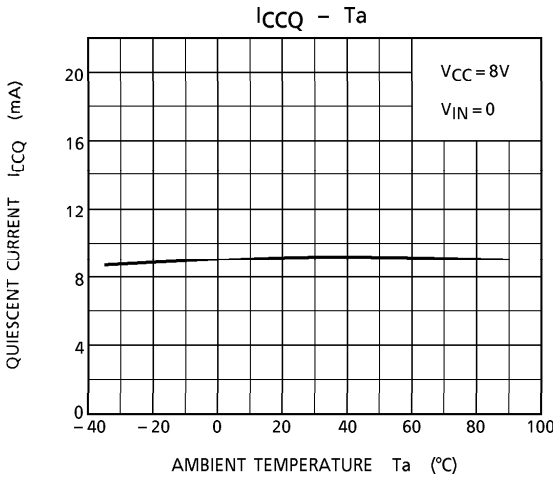

APPLICATION BLOCK DIAGRAM

(1) Noninverting line output

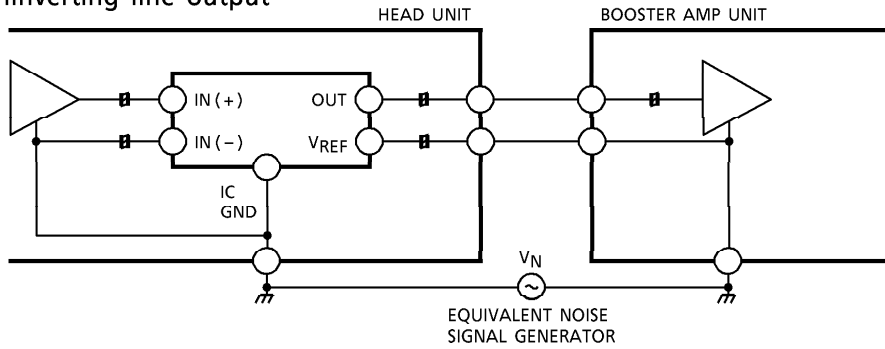

(2) Inverting line output

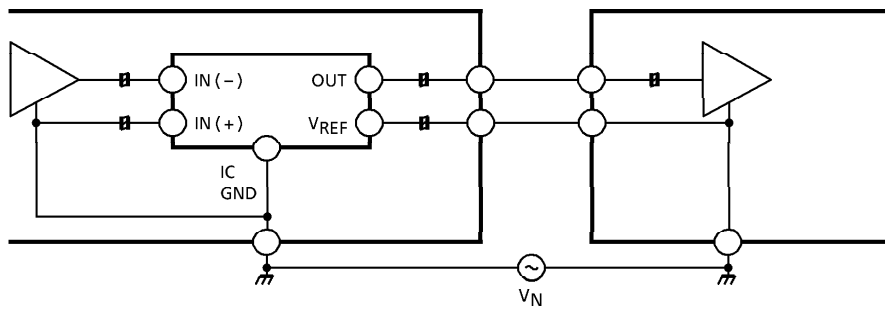

(3) Noninverting line input

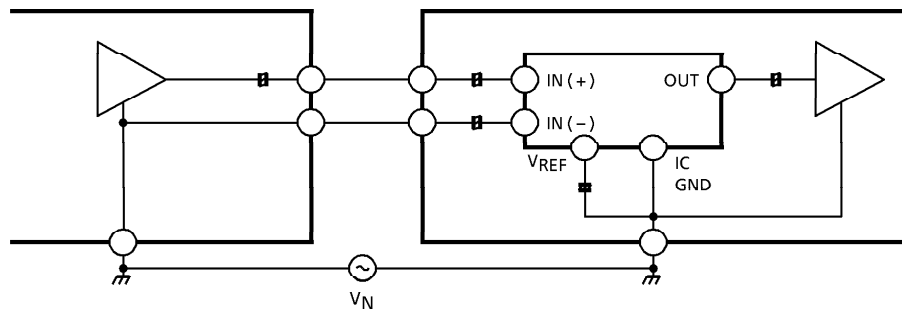

(4) Inverting line input

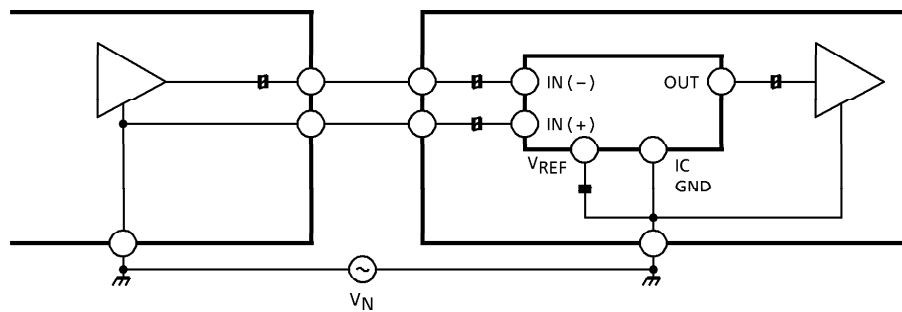

OUTLINE DRAWING
SIP9-P-2.54A

Unit : mm

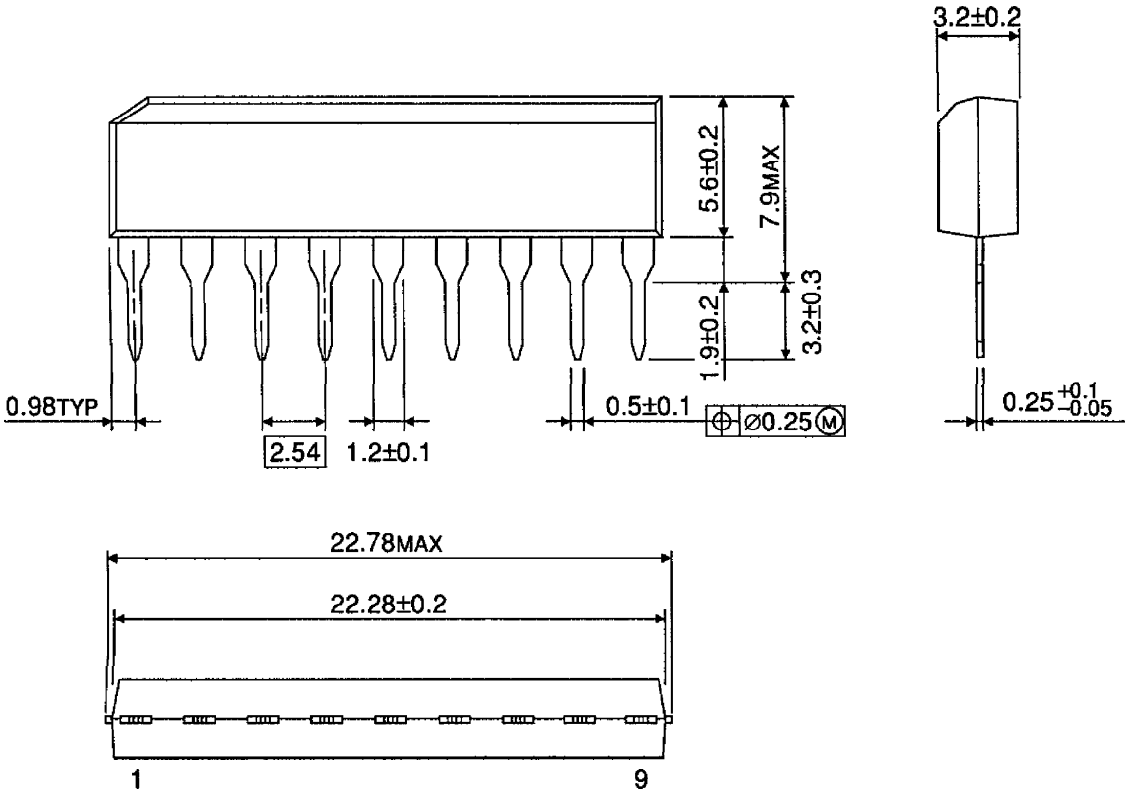

Weight : 0.92g (Typ.)

OUTLINE DRAWING
SSOP16-P-225-1.00A

Unit : mm

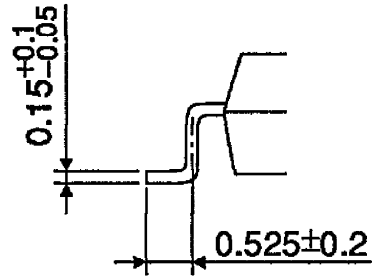
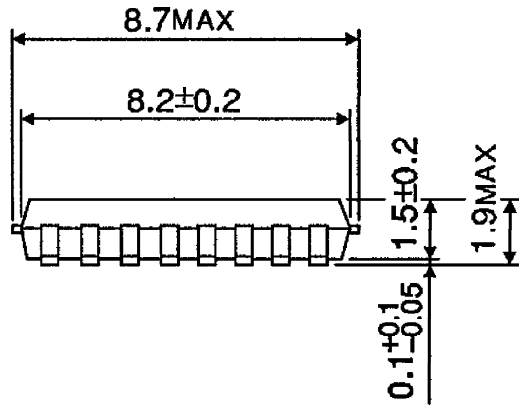
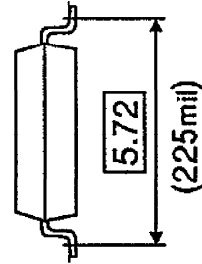
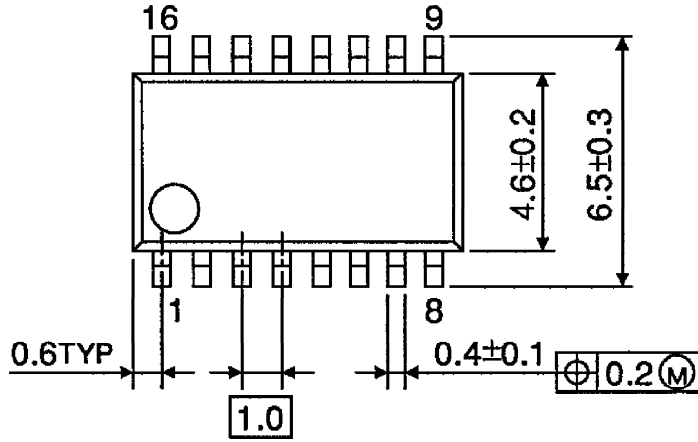

Weight : 0.14g (Typ.)