

TENTATIVE

TOSHIBA GATE TURN-OFF THYRISTOR

SG1500GXH25

INVERTER APPLICATION

Unit in mm

- Repetitive Peak Off-State Voltage : $V_{DRM} = 4500\text{ V}$
(Note 1)
- Repetitive Peak Reverse Voltage : $V_{RRM} = 4000\text{ V}$
- R.M.S On-State Current : $I_T(\text{RMS}) = 750\text{ A}$
- Peak Turn-Off Current : $I_{TGQM} = 1500\text{ A}$
- Critical Rate of Rise of On-State Current : $di/dt = 250\text{ A}/\mu\text{s}$
- Critical Rate of Rise of Off-State Voltage : $dv/dt = 900\text{ V}/\mu\text{s}$

MAXIMUM RATINGS

CHARACTERISTIC	SYMBOL	RATING	UNIT
Repetitive Peak Off-State Voltage (Note 1)	V_{DRM}	4500	V
Repetitive Peak Reverse Voltage	V_{RRM}	4000	V
Peak Turn-Off Current (Note 2)	I_{TGQM}	1500	A
R.M.S On-State Current (Note 3)	$I_T(\text{RMS})$	750	A
Peak One Cycle Surge On-State Current (Non Repetitive, 10 ms- Width Half Sine Waveform)	I_{TSM}	8000 (50 Hz)	A
		9000 (60 Hz)	
Critical Rate of Rise of On-State Current (Note 4)	di/dt	250	A / μs
Peak Forward Gate Current	I_{FGM}	70	A
Average Gate Power Dissipation	$P_G(\text{AV})$	150	W
R.M.S Gate Current (Note 5)	$I_G(\text{RMS})$	42	A
Peak Reverse Gate Voltage (At Static)	V_{RGM}	15	V
Operation Junction Temperature Range	T_j	-40~115	°C
Storage Temperature Range	T_{stg}	-40~115	°C
Mounting Force	—	19.6 ± 2.0	kN

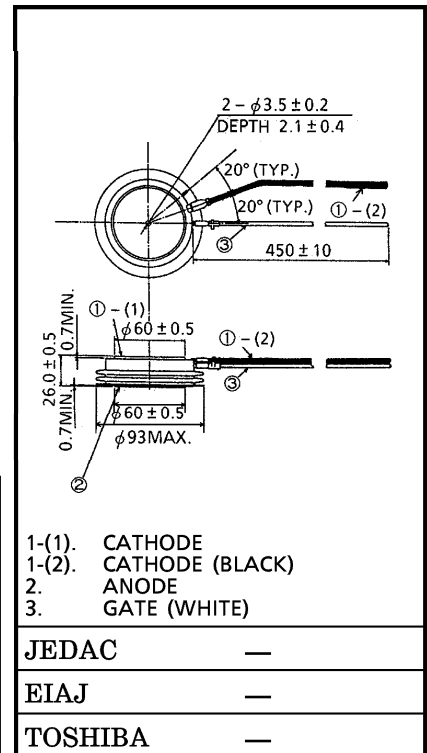

Weight : 800 g

(Note 1) : $V_{GK} = -2\text{ V}$

(Note 2) : $V_D = 2400\text{ V}$, $V_{DM} \leq 3000\text{ V}$, $C_S \geq 3\ \mu\text{F}$, $di_{GQ}/dt \geq 35\text{ A}/\mu\text{s}$, $V_{DSP} \leq 750\text{ V}$,
 $L_S \leq 0.2\ \mu\text{H}$ (TOSHIBA METHOD)

(Note 3) : 50 Hz Half Sine Waveform

(Note 4) : $V_D \leq 2250\text{ V}$, $I_{TM} \leq 1500\text{ A}$, $I_G \geq 20\text{ A}$ ($t_r \leq 1\ \mu\text{s}$), $f \leq 50\text{ Hz}$, $C_S \leq 3\ \mu\text{F}$,
 $R_S \geq 10\ \Omega$, $25^\circ\text{C} \leq T_j \leq 115^\circ\text{C}$

(Note 5) : Ambient Temperature of coaxial gate-cathode lead = 90°C

961001EAA2

- TOSHIBA is continually working to improve the quality and the reliability of its products. Nevertheless, semiconductor devices in general can malfunction or fail due to their inherent electrical sensitivity and vulnerability to physical stress. It is the responsibility of the buyer, when utilizing TOSHIBA products, to observe standards of safety, and to avoid situations in which a malfunction or failure of a TOSHIBA product could cause loss of human life, bodily injury or damage to property. In developing your designs, please ensure that TOSHIBA products are used within specified operating ranges as set forth in the most recent products specifications. Also, please keep in mind the precautions and conditions set forth in the TOSHIBA Semiconductor Reliability Handbook.
- The information contained herein is presented only as a guide for the applications of our products. No responsibility is assumed by TOSHIBA CORPORATION for any infringements of intellectual property or other rights of the third parties which may result from its use. No license is granted by implication or otherwise under any intellectual property or other rights of TOSHIBA CORPORATION or others.
- The information contained herein is subject to change without notice.

ELECTRICAL CHARACTERISTICS

CHARACTERISTIC	SYMBOL	TEST CONDITION	MIN	TYP.	MAX	UNIT	
Repetitive Peak Off-State Current	I_{DRM}	$V_{DRM} = 4500 \text{ V}$, $V_{GK} = -2 \text{ V}$ $T_j = 115^\circ\text{C}$	—	—	80	mA	
Repetitive Peak Reverse Current	I_{RRM}	$V_{RRM} = 4000 \text{ V}$ $T_j = 115^\circ\text{C}$	—	—	80	mA	
Repetitive Peak Reverse Gate Current	I_{RGM}	$V_{RGM} = 15 \text{ V}$ $T_j = 115^\circ\text{C}$	—	—	10	mA	
Peak On-State Voltage	V_{TM}	$I_{TM} = 1500 \text{ A}$, $T_j = 115^\circ\text{C}$	—	—	4.7	V	
Gate Trigger Voltage	V_{GT}	$V_D = 24 \text{ V}$ $R_L = 0.1 \Omega$	$T_j = -40^\circ\text{C}$	—	—	1.7	V
			$T_j = 25^\circ\text{C}$	—	—	1.2	V
Gate Trigger Current	I_{GT}	$R_L = 0.1 \Omega$	$T_j = -40^\circ\text{C}$	—	—	5.5	A
			$T_j = 25^\circ\text{C}$	—	—	1.5	A
Turn-On Delay Time	t_d	$V_D = 2250 \text{ V}$, $I_{TM} = 1500 \text{ A}$ $di_F/dt = 250 \text{ A}/\mu\text{s}$	—	—	3.0	μs	
Turn-On Time	t_{gt}	$I_{GM} = 15 \text{ A}$ ($t_r = 1 \mu\text{s}$) $T_j = 25^\circ\text{C}$, non-snubber	—	—	12	μs	
Critical Rate of Rise of Off-State Voltage	dv/dt	$V_{DRM} = 3000 \text{ V}$ $T_j = 115^\circ\text{C}$, $V_{GK} = -2 \text{ V}$ Exponential Rise	900	—	—	$\text{V}/\mu\text{s}$	
Storage Time	t_s	$I_{TGQ} = 1500 \text{ A}$	—	—	17	μs	
Gate Turn-Off Time	t_{gq}	$V_{DM} = 3000 \text{ V}$, $T_j = 115^\circ\text{C}$	—	—	19	μs	
Tail Time	t_{tail}	$V_D = 2250 \text{ V}$, $C_S = 3 \mu\text{F}$ $di_{GQ}/dt = 35 \text{ A}/\mu\text{s}$	—	—	200	μs	
Gate Turn-Off Current	I_{GQ}	Off squeeze current $\geq 300 \text{ mA}$	—	—	500	A	
Reverse Recovery Charge	Q_{rr}	$I_T = 1500 \text{ A}$, $V_R = 1500 \text{ V}$ $C_S = 3 \mu\text{F}$, $R_S = 10 \Omega$	—	—	4000	μC	
Reverse Recovery Time	t_{rr}	$di_T/dt = -200 \text{ A}/\mu\text{s}$ $T_j = 115^\circ\text{C}$	—	—	10	μs	
Thermal Resistance	$R_{th(j-f)}$	Junction to fin	—	—	0.018	$^\circ\text{C}/\text{W}$	

