

TA8106F

STEREO HEADPHONE POWER AMPLIFIER (1.5V USE)

The TA8106F is a Dual headphone amplifier IC designed for low voltage operation (1.5V, 3.0V), which is suitable for stereo headphone radio and radio cassette recorder equipments. This item can realize the low power dissipation and have high power output capability.

FEATURES

- Condenser-less for input and output.
- Condenser-less for bootstrap.
- Built-in the muting function.
- High power output capability according to adopting the Matrix Drive Method.

$$\begin{cases} P_{O(1)} = 14\text{mW/ch (Typ.) at } V_{in(R)} = V_{in(L)} \text{ mode} \\ P_{O(2)} = 5.5\text{mW/ch (Typ.) at } V_{in(R)} = -V_{in(L)} \text{ mode} \\ P_{O(3)} = 10.5\text{mW/ch (Typ.) at } V_{in(R)} = 0 \text{ or } V_{in(L)} = 0 \\ (V_{CC} = 1.5\text{V, } R_L = 32\Omega, f = 1\text{kHz, THD} = 10\%) \end{cases}$$

- Operating supply voltage range. : $V_{CC(opr)} = 0.9 \sim 5.0\text{V}$ ($T_a = 25^\circ\text{C}$)

BLOCK DIAGRAM

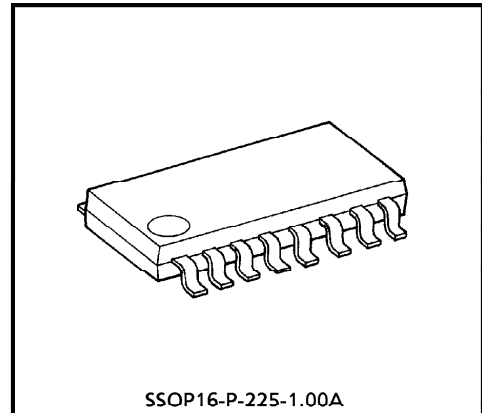
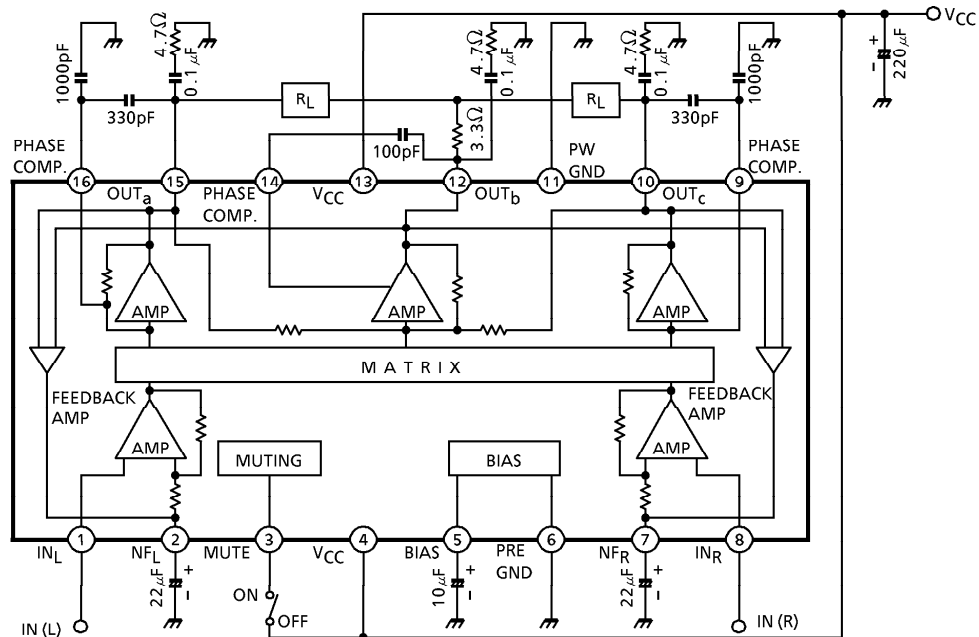

SSOP16-P-225-1.00A

Weight : 0.14g (Typ.)

961001EBA2

● TOSHIBA is continually working to improve the quality and the reliability of its products. Nevertheless, semiconductor devices in general can malfunction or fail due to their inherent electrical sensitivity and vulnerability to physical stress. It is the responsibility of the buyer, when utilizing TOSHIBA products, to observe standards of safety, and to avoid situations in which a malfunction or failure of a TOSHIBA product could cause loss of human life, bodily injury or damage to property. In developing your designs, please ensure that TOSHIBA products are used within specified operating ranges as set forth in the most recent products specifications. Also, please keep in mind the precautions and conditions set forth in the TOSHIBA Semiconductor Reliability Handbook.

SUMMARY OF MATRIX DRIVE METHOD

Though the BTL is usually used to obtain enough power at low voltage, it can not be used for the headphone amplifier (especially, 1.5V USE), which has only one left-and right common line.

Then a new modified BTL drive method is developed, which is called "Matrix Drive Method". It has only one common line.

Fig.1 Shows the Principle. The input signals of the audio frequency are applied to the terminal of L /R. These are transformed by the matrix converter into the outputs, as following ;

$$\begin{cases} V_{(a)} = L - \alpha R \\ V_{(b)} = -\alpha (L + R) \\ V_{(c)} = R - \alpha L \end{cases} \left\{ \begin{array}{l} L, R : \text{input signal} \\ \alpha : \text{matrix ratio} \end{array} \right.$$

And the output signals of L/R loads are given by

$$\begin{cases} V_L = V_{(a)} - V_{(b)} = (1 + \alpha) L \\ V_R = V_{(c)} - V_{(b)} = (1 + \alpha) R \end{cases}$$

Thus, each output signal does not leak to another channel load.

This gain is $(1 + \alpha)$ times as high as a conventional single amplifiers'. However the undistorted maximum output is determined by each clipping point of lines, (a), (b) and (c). Therefore, the most effective point is determined by the following states of input. As the state of input is at $L=R$ mode, α is $1/3$, so this system is operated most effectively. At $L = -R$ mode, α is whatever. And at single input mode (L or R only), α is 1.

It is a common saying that the practical musical source consists of the common phase component in most. And the low frequency of that causes the clipping to product mostly. Therefore in this item, α is $1/3$.

In result at $L=R$ mode, this gain is obtained twice as high as a single amplifiers.

At single input mode, $4/3$ times, at $L = -R$ mode, is obtained as same as a single.

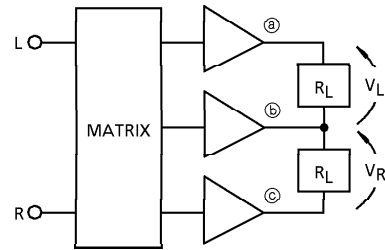

Fig.1

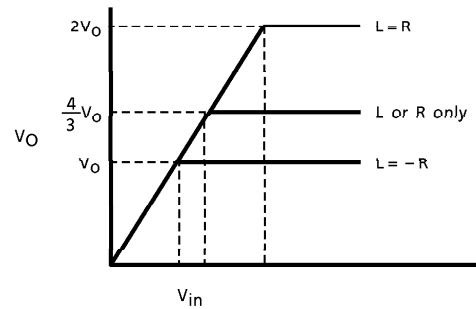

Fig.2

APPLICATION NOTE

(1) Input stage

The first stage is composed of the differential amplifier of PNP-input. Therefore, it is not necessary to use any coupling condensers (Fig.3).

The input impedance is determined by the internal resistance (51kΩ).

This output is connected to the next stage through the emitter follower.

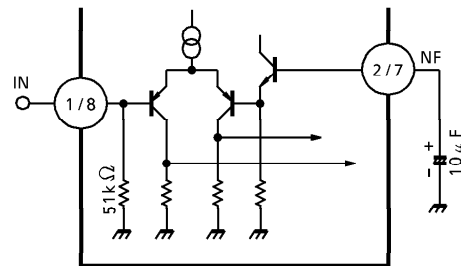

Fig.3

961001EBA2'

- The products described in this document are subject to foreign exchange and foreign trade control laws.
- The information contained herein is presented only as a guide for the applications of our products. No responsibility is assumed by TOSHIBA CORPORATION for any infringements of intellectual property or other rights of the third parties which may result from its use. No license is granted by implication or otherwise under any intellectual property or other rights of TOSHIBA CORPORATION or others.
- The information contained herein is subject to change without notice.

(2) Matrix converter

The matrix ratio is determined by the amplifier A₁, A₂, as shown in Fig.4. Each of the output currents, which have a ratio (1 : α), is formed by A₁, A₂.

The outputs of matrix converter, which are previously mentioned, are

$$\begin{cases} V_{\text{a}} = L - \alpha R \\ V_{\text{b}} = -\alpha (L + R) \\ V_{\text{c}} = R - \alpha L \end{cases}$$

These are applied to the drivers B₁, C, B₂.

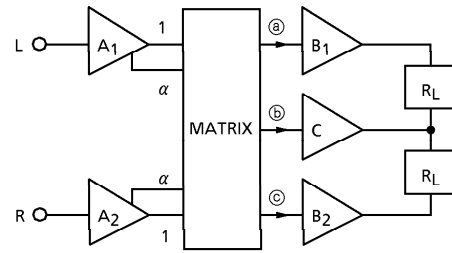

Fig.4

(3) Muting function

As the terminal pin ③ for the muting function is connected to V_{CC}, Q₁ is turned on, then Q₂ and Q₃ are turned on. Therefore the DC voltage of the terminal pin ⑤ is down, and all of the circuits stop. At this time, the quiescent supply current (I_{CCQ}) scarcely flows into this system. As the terminal pin ③ is opened, the DC voltage of the terminal pin ⑤ does not quickly come up, because of the presence of the CR time-constant. So, the shock-noise is reduced. As the supply voltage is turned on, this operation is also done.

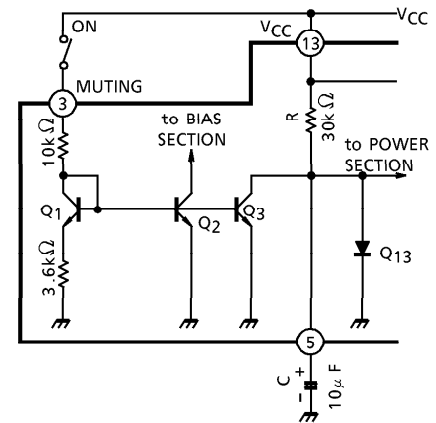

Fig.5

(4) DC Feed-Back circuit

In this system, the output loads are directly connected to the output terminals. Therefore, in order that the output DC offset voltages are reduced, this system is built-in the DC feed-back circuit. The currents, which are in proportion of the differential voltage between two DC terminal voltages in each

$$I_1 = K (V_{\text{a}} - V_{\text{b}})$$

$$I_2 = K (V_{\text{c}} - V_{\text{b}})$$

are fed into the matrix converter.

Thus the DC offset voltages are reduced. This system is effective more than about 1.2V.

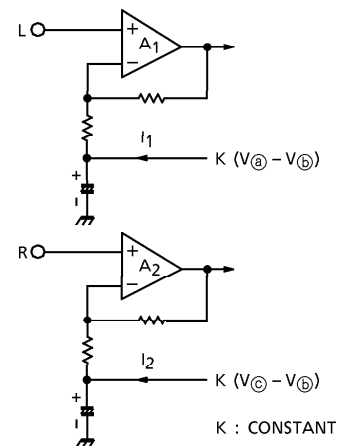

Fig.6

(5) Oscillation precaution

Small temperature coefficient and excellent frequency characteristic is needed by capacitors below.

- Oscillation preventing capacitors for power amplifier output.
- Capacitor between V_{CC} and GND

(6) Total gain : G_V

In this system, the total gain G_V is given by

$$G_V = 20 \log \frac{4 \times R_2}{R_1}$$

Typical values of this system is $R_1 = 1.6k\Omega$, $R_2 = 19k\Omega$, then this gain is ;

$$G_V \approx 34\text{dB (Typ.)}$$

(Note) The internal resistances are fixed, then the gain is fixed. In addition to the attenuator in front of this system, the gain is changeable.

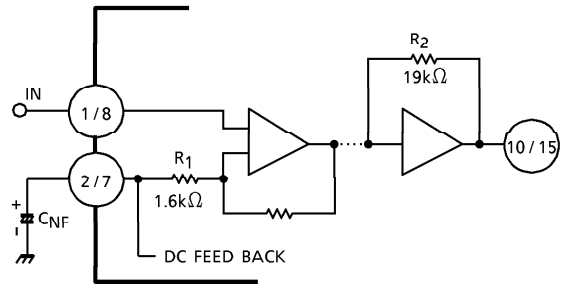

Fig.7

MAXIMUM RATINGS (Ta = 25°C)

CHARACTERISTIC	SYMBOL	RATING	UNIT
Supply Voltage	V_{CC}	5	V
Output Current	$I_{O(peak)}$	160	mA
Power Dissipation	P_D (Note)	350	mW
Operating Temperature	T_{opr}	-25~75	°C
Storage Temperature	T_{stg}	-55~150	°C

(Note) Derated above $T_a = 25^\circ\text{C}$ in the proportion of $2.8\text{mW}/^\circ\text{C}$.

ELECTRICAL CHARACTERISTICS (AC)

(Unless otherwise specified, $T_a = 25^\circ\text{C}$, $V_{CC} = 1.5\text{V}$, $f = 1\text{kHz}$, $R_g = 620\Omega$, $R_L = 32\Omega$)

CHARACTERISTIC	SYMBOL	TEST CIR-CUIT	TEST CONDITION	MIN.	TYP.	MAX.	UNIT
Quiescent Supply Current	I_{CCQ}	—	$V_{in} = 0$	—	6	8.4	mA
Input Resistance	R_{IN}	—		—	50	—	k Ω
Voltage Gain	G_V	—	$V_{in} = -50\text{dBV}$	30	33	36	dB
Channel Balance	ΔG_V	—	$V_{in(R)} = V_{in(L)}$	—	0	1.3	dB
Output Power	$P_o(1)$	—	$V_{in(R)} = V_{in(L)}$ THD = 10%	11	14	—	mW
	$P_o(2)$	—	$V_{in(R)} = -V_{in(L)}$ THD = 10%	—	5.5	—	
	$P_o(3)$	—	$V_{in(R)} = 0$ or $V_{in(L)} = 0$ THD = 10%	—	10.5	—	
Total Harmonic Distortion	THD (1)	—	$P_o(L) = P_o(R) = 1\text{mW}$ $V_{in(R)} = V_{in(L)}$	—	0.4	1.0	%
	THD (2)	—	$P_o(L) = P_o(R) = 1\text{mW}$ $V_{in(R)} = -V_{in(L)}$	—	2.5	—	
	THD (3)	—	$V_{in(R)} = 0$ or $V_{in(L)} = 0$ $P_o = 1\text{mW}$	—	0.9	—	
Output Noise	V_{no}	—	$R_g = 620\Omega$, BPF = 20Hz~20kHz	—	0.15	0.3	mV _{rms}
Cross Talk	CT	—	$V_o = -10\text{dBV}$, $R_g = 620\Omega$	—	32	—	dB
Ripple Rejection Ratio	RR	—	$V_r = -30\text{dBV}$ $f_r = 100\text{Hz}$, $R_g = 620\Omega$	—	35	—	dB
Muting Attenuation	ATT	—	$V_{MUTE} = 1.5\text{V}$	—	60	—	dB

DC CHARACTERISTICS ($V_{CC} = 1.5V$, $T_a = 25^\circ C$, terminal voltage at no signal)

PIN No.	SYMBOL	TYP.	UNIT
PIN ① (INPUT L)	V_1	0.16	V
PIN ② (NF L)	V_2	0.73	V
PIN ③ (MUTE)	V_3	—	V
PIN ④ (V_{CC})	V_4	1.50	V
PIN ⑤ (BIAS)	V_5	0.74	V
PIN ⑥ (PRE GND)	V_6	0	V
PIN ⑦ (NF R)	V_7	0.73	V
PIN ⑧ (INPUT R)	V_8	0.16	V
PIN ⑨ (PHASE COMPENSATION)	V_9	0.80	V
PIN ⑩ (OUTPUT)	V_{10}	0.75	V
PIN ⑪ (PW GND)	V_{11}	0	V
PIN ⑫ (OUTPUT)	V_{12}	0.75	V
PIN ⑬ (V_{CC})	V_{13}	1.50	V
PIN ⑭ (PHASE COMPENSATION)	V_{14}	0.80	V
PIN ⑮ (OUTPUT)	V_{15}	0.75	V
PIN ⑯ (PHASE COMPENSATION)	V_{16}	0.80	V

TEST CIRCUIT

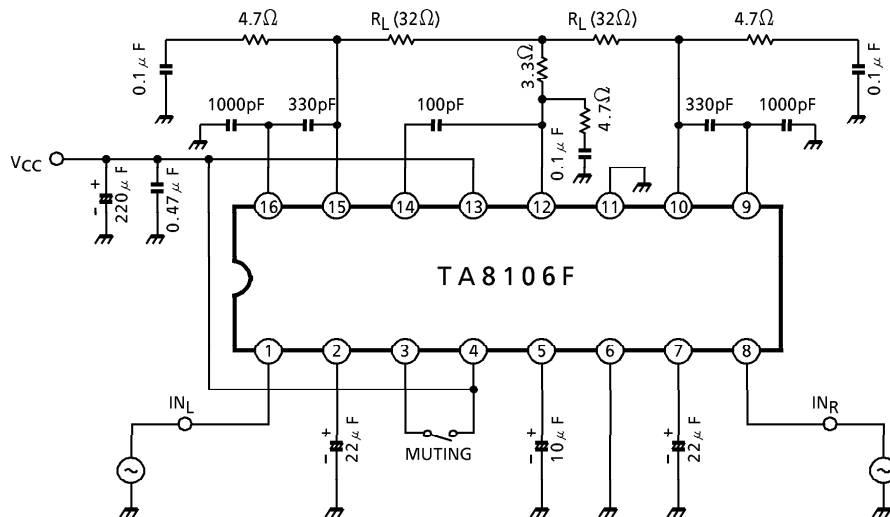

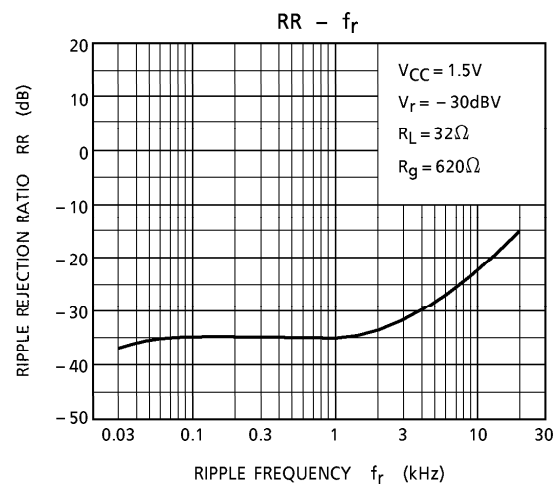
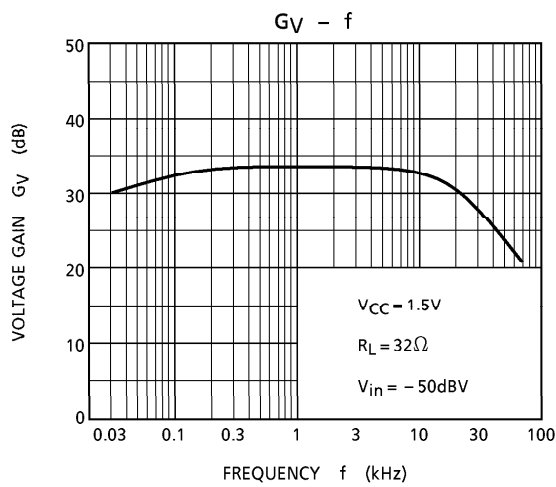
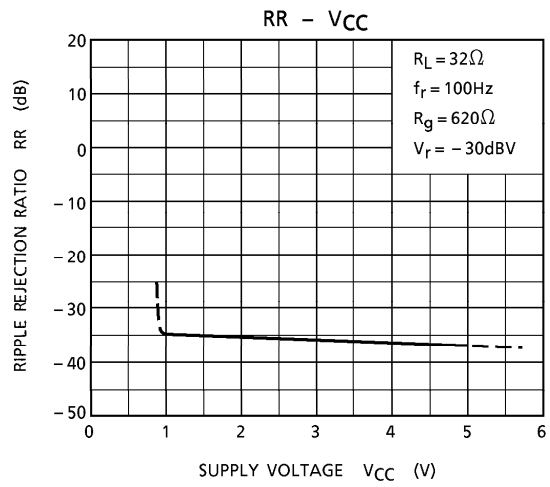
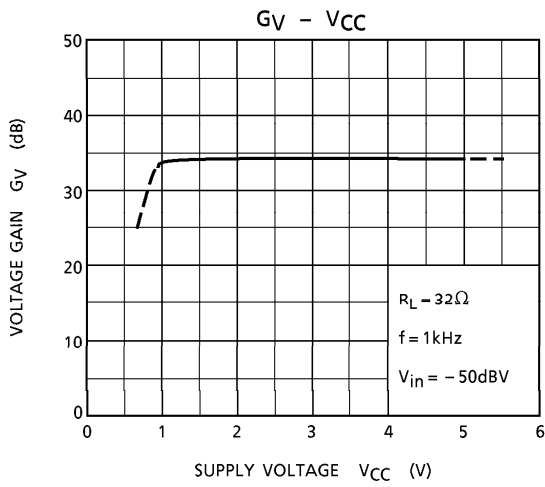
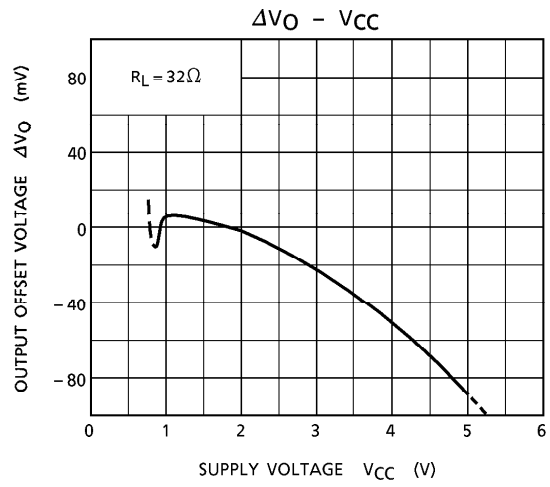
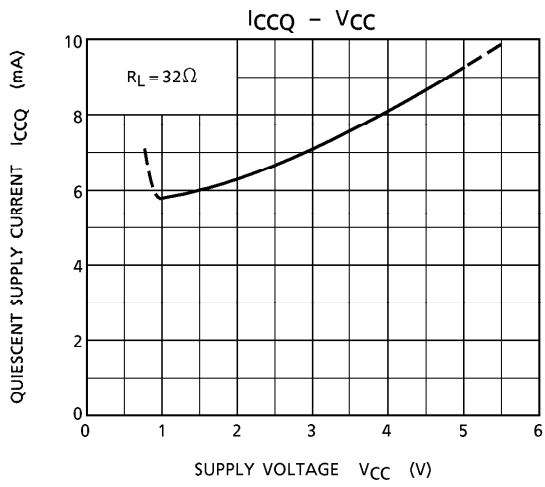

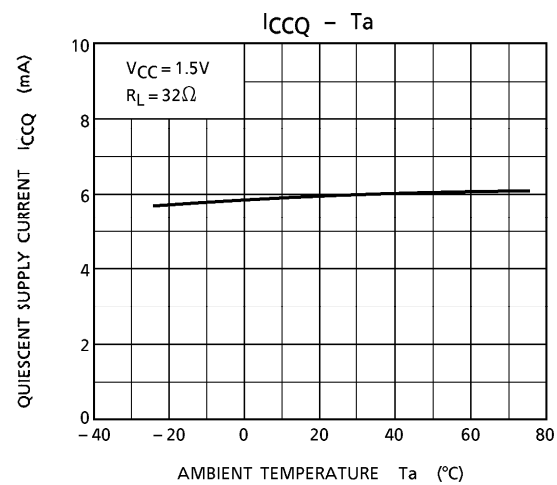
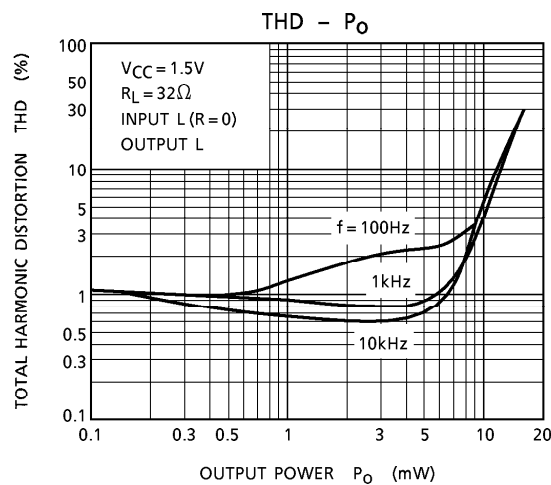
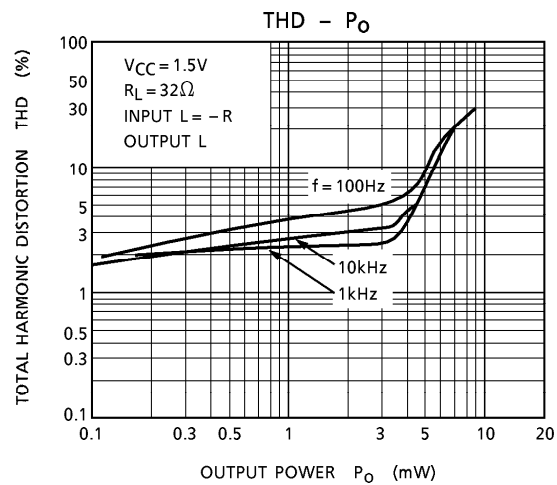
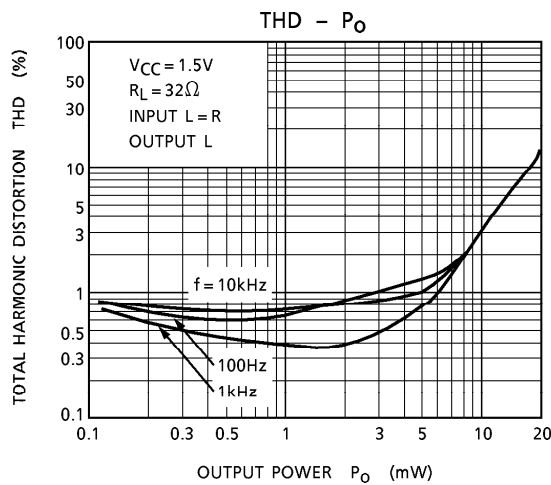
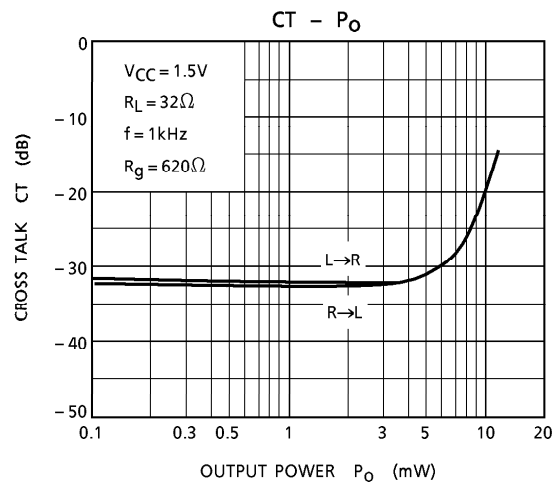
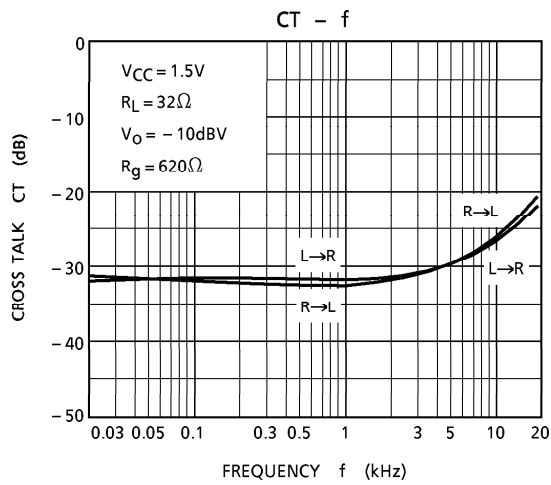

OUTLINE DRAWING
SSOP16-P-225-1.00A

Unit : mm

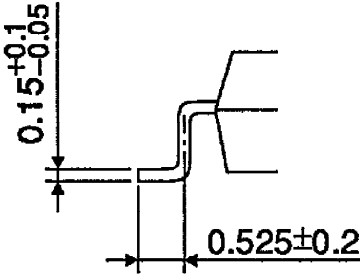
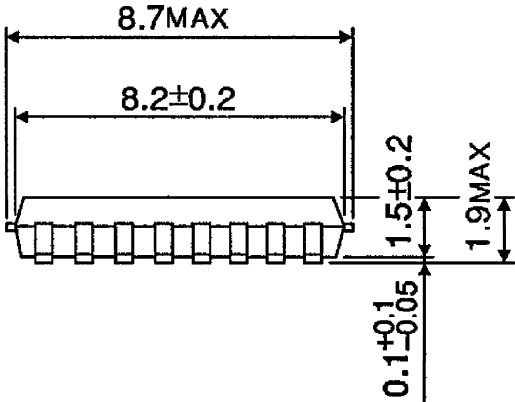
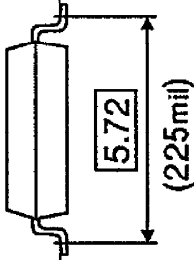
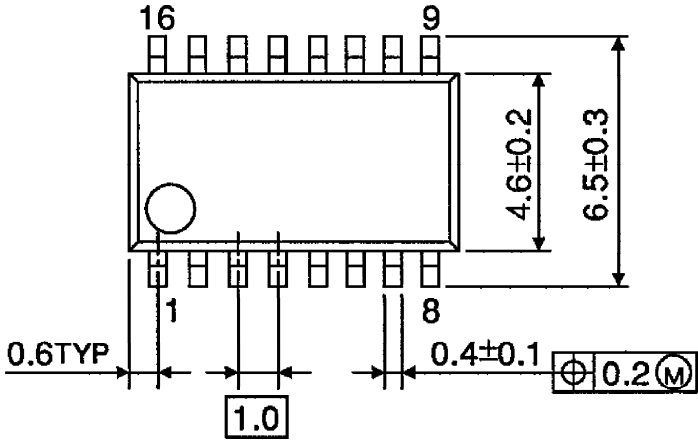

Weight : 0.14g (Typ.)