



## CD series

### CMOS IC Time Delay Relay

- 1% Repeatability
- Operates from -40°C to +55°C
- Delay on operate or delay on release timing modes
- Fixed, knob or resistor adjustable types
  - Calibrated dial on knob adjustable types
- 10A output relay with SPDT or DPDT contacts
- Various models time from 0.1 to 180 sec.

File E22575

File LR15734

#### Timing Modes

**Delay on operate** – Delay period begins when input voltage is applied. At the end of the delay period, the relay will operate and will not release until input voltage is removed. Reset occurs when input voltage is reapplied.

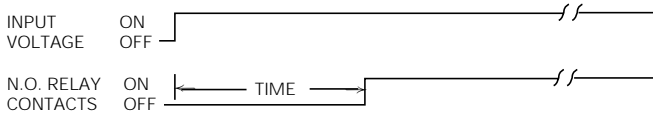

**Delay on release** – Input voltage must be applied continuously to operate the internal relay. When control input is applied, the relay energizes. When control input is removed, timing begins. When timing is complete, the relay will de-energize. Time may be reset to zero during timing by reapplying control input.

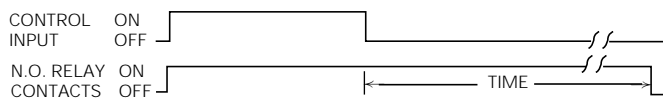

#### Timing Specifications

**Timing Ranges:** From 0.1 to 180 sec.

**Timing Adjustment:** Fixed, external resistor and knob adjustable.

**Tolerance (for AC units add ±1/2 cycle 60 Hz.):**

**Knob Adj. Types:** ±5% of max. specified at high end of timing range; min. specified, or less, at low end; ±10% full scale.

**Fixed Types:** ±5%.

**Res. Adj. Types:** ±5% at high end of timing range; min. specified, or less, at low end.

**Delta Time (for AC units add ±1 cycle 60 Hz.):** ±5%.

**Repeatability (for AC units add ±1 cycle 60 Hz.):** ±1%.

**Release Time:** 45 ms, typ.; 60 ms, max.

**Recycle Time:** 45 ms, typ.; 60 ms, max.

#### Contact Data @ 25°C

**Arrangements:** 2 Form C (DPDT).

**Material:** Silver-cadmium oxide alloy.

**Rating:** 10A @ 30VDC or 277VAC, resistive; 1/2 HP @ 250VAC; 1/3 HP @ 120VAC.

**Expected Mechanical Life:** 10 million operations.

**Expected Electrical Life:** 100,000 operations, min., at rated load.

#### Initial Dielectric Strength

**Between Open Contacts:** 500V rms, 60 Hz.

**Between All Other Conductors:** 500V rms, 60 Hz.

#### Input Data @ 25°C

**Voltage:** 24 & 120VAC and 12 through 110VDC.

**Power Requirement: AC Types:** Typically less than 3 VA.

**DC Types:** Typically less than 3 W.

**Transient Protection:** Yes.

**Reverse Voltage Protection:** Yes.

#### Input Voltages & Limits @ 25°C

Voltage Type	Nominal Voltage	Minimum Voltage	Maximum Voltage
AC	24	20	28
	120	105	130
DC	12	11	13
	24	20	32
	48	41	55
	110	95	125

**Note:** DC voltage must be filtered (5% p-p ripple max. at nom. voltage).  
AC models will operate on 50 or 60 Hz.

#### Environmental Data

**Temperature Range: Storage:** -55°C to +85°C.

**Operating:** -40°C to +55°C.

#### Mechanical Data

**Termination:** 8- or 11-pin octal style plug.

**Enclosure:** Yellow plastic case. Knob adjustable types have dial scale calibrated in seconds ±5%.

**Sockets:** Models with 8-pin base fit either 27E122 or 27E891 (snap-on) screw terminal sockets. 11-pin types fit either 27E123 or 27E892 (snap-on) screw terminal sockets.

**Weight:** 8 oz. (227g) approximately.

Ordering Information – Boldface items listed below are normally maintained in stock for immediate delivery.

Delay on Operate Models

Voltage	Time	Adjustment	Wiring Dia.	Part Number
120VAC	0.1 to 1 Sec.	Knob	1	<b>CDB-38-70001</b>
	0.1 to 5 Sec.			<b>CDB-38-70002</b>
	0.1 to 10 Sec.			<b>CDB-38-70003</b>
	0.3 to 30 Sec.			<b>CDB-38-70006</b>
	0.6 to 60 Sec.			<b>CDB-38-70004</b>
	1.8 to 180 Sec.	<b>CDB-38-70005</b>		
120VAC	1 Sec.	Fixed		<b>CDA-38-70012</b>
120VAC	0.1 to 1 Sec.	Resistor	2	CDF-38-70001
	0.1 to 5 Sec.			<b>CDF-38-70002</b>
	0.1 to 10 Sec.			CDF-38-70003
24VDC	0.1 to 10 Sec.	Knob	1	<b>CDD-38-30003</b>
	0.6 to 60 Sec.			<b>CDD-38-30004</b>
	1.8 to 180 Sec.			<b>CDD-38-30005</b>
48VDC	0.6 to 60 Sec.	Knob	1	CDD-38-40002
110VDC	0.1 to 1 Sec.	Knob	1	CDD-38-60004
	0.1 to 10 Sec.			CDD-38-60001
	0.6 to 60 Sec.			CDD-38-60002
	1.8 to 180 Sec.			CDD-38-60003

Delay on Release Models

Voltage	Time	Adjustment	Wiring Dia.	Part Number
120VAC	0.1 to 1 Sec.	Knob	3	<b>CDB-38-70016</b>
	0.1 to 5 Sec.			<b>CDB-38-70091</b>
	0.1 to 10 Sec.			<b>CDB-38-70014</b>
	0.3 to 30 Sec.			<b>CDB-38-70092</b>
	0.6 to 60 Sec.			<b>CDB-38-70012</b>
	1.8 to 180 Sec.	<b>CDB-38-70015</b>		
120VAC	1 Sec.	Fixed	3	CDA-38-70025
12VDC	180 Sec.	Fixed	3	CDC-38-20026
24VDC	0.1 to 10 Sec.	Knob	3	<b>CDD-38-30014</b>
	0.6 to 60 Sec.			<b>CDD-38-30012</b>
	1.8 to 180 Sec.			<b>CDD-38-30008</b>

Outline Dimensions

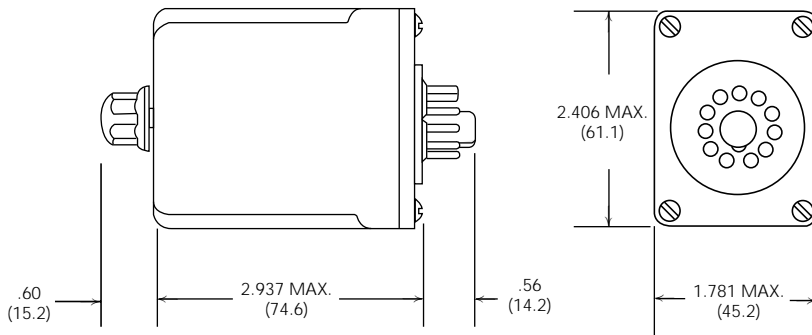

Wiring Diagrams – Bottom Views (pins numbered clockwise from keyway)

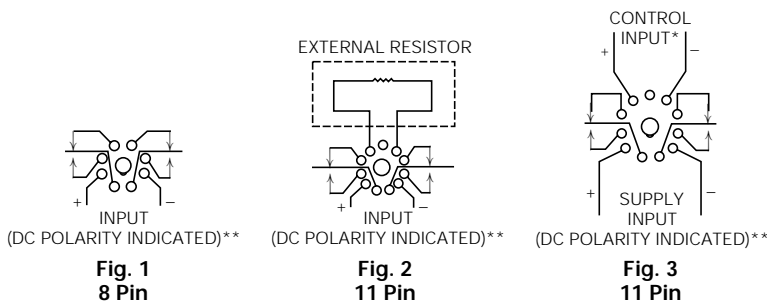

\* If control input is applied when supply input is applied, relay will immediately energize. A 50 millisecond minimum control pulse is required.  
 \*\* Note Input polarity for DC operation. For most reliable operation on AC, connect high side to "+" and low side to "-".

External Resistor Selection Chart

See External Resistor Selection Charts at beginning of Time Delay Relay section of this Databook.