

FP2 Series

Features

- Compact and thin. (Height=1.3mm)
- Excellent vibration resistance and shock resistance.
- Designed for automatic mounting and reflow soldering.

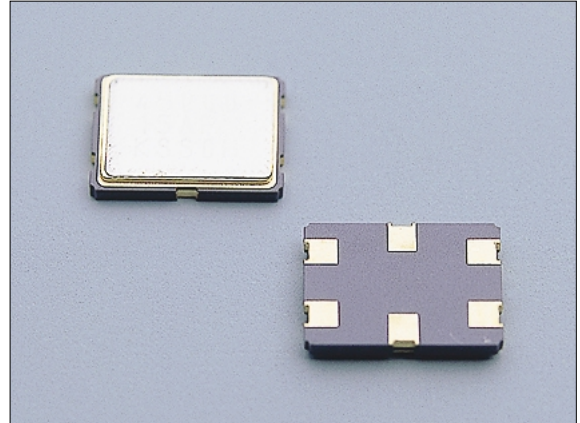

Specifications

Type	Number of inner units	Pass Bandwidth		Ripple	Insertion Loss	Stop Bandwidth		Terminating Impedance	Operating Temp.Range
		dB	kHz MIN	dB MAX	dB MAX	dB	kHz MAX	$\Omega/\mu\text{F}$	$^{\circ}\text{C}$
MXF21.4-15A-FP2	1	3	± 7.5	0.5	1.5	18	± 25	1.5k//2.5	-20~+70
MXF21.7-8A-FP2	1	3	± 3.5	1	2	16	± 12.5	1.5k//6	-20~+70
MXF45-15AF-FP2	1	3	± 7.5	1	2.5	14	± 25	550//3	-20~+70
MXF45-30AF-FP2	1	3	± 15	1	2	15	± 50	1.2k//1.5	-20~+70
MXF55-26AF-FP2	1	3	± 13	1	3	27	± 100	750//2.7	-20~+70

* Taping item packaging : one unit 1,000 pcs

Outline

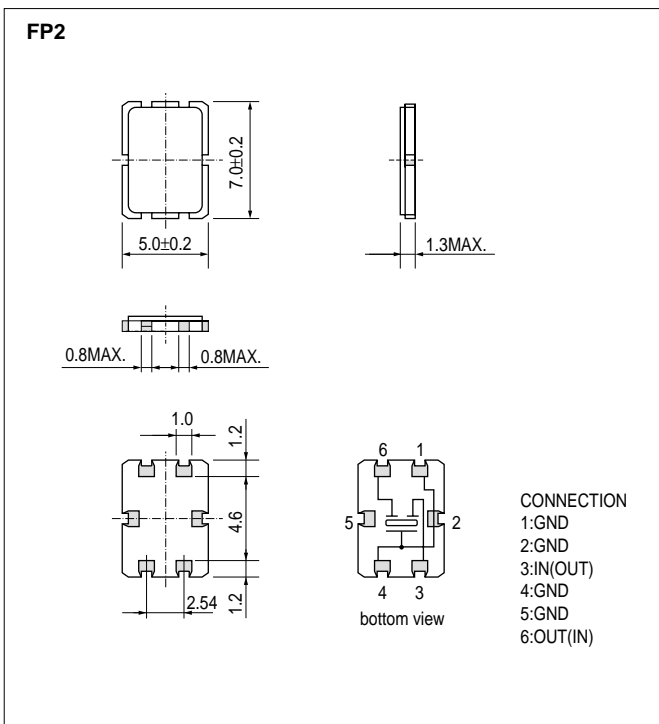

Land Pattern(reference)

