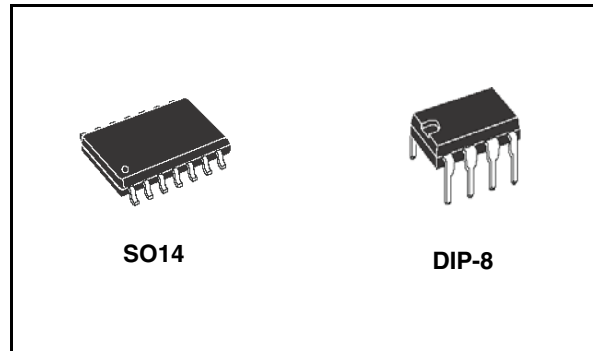

Interface circuit - relay and lamp-driver**Features**

- Open ground protection
- High output current
- Adjustable short-circuit protection to ground
- Thermal protection with hysteresis to avoid the intermediate output levels
- Large supply voltage range: + 8V to +45V
- Short-circuit protection to V_{CC}

**Description**

The TDE1747 is a monolithic comparator designed for high current and high voltage applications, specifically to drive lamps, relays, stepping motors.

This device is essentially blow-out proof. Current limiting is available to limit the peak output current to safe values.

Adjustment only requires one external resistor. In addition, thermal shut down is provided to keep the IC from overheating. If internal dissipation becomes too high, the driver will shut down to prevent excessive heating. TDE1747 has an open ground protection. The output is also protected from shortcircuits with the positive power supply. The device operates over a wide range of supply voltages from standard $\pm 15V$ operational amplifier supplies down to the single +12V or +24V used for industrial electronic systems.

Order codes

Part number	Temp range, °C	Package	Packing
TDE1747DP	-25°C to +85°C	DIP-8	Tube
TDE1747FP	-25°C to +85°C	SO14	Tube
TDE1747FPT	-25°C to +85°C	SO14	Tape and reel

Contents

1	Maximum ratings	3
1.1	Absolute maximum ratings	3
1.2	Thermal data	3
2	Electrical characteristics	4
3	Pin connections and schematic diagrams	5
4	Typical characteristics	7
5	Typical applications	10
6	Waveforms	12
7	Package mechanical data	13
8	Revision history	16

1 Maximum ratings

1.1 Absolute maximum ratings

Table 1. Absolute maximum ratings

Symbol	Parameter	Value	Unit
V_{CC}	Supply voltage	50 ⁽¹⁾	V
v_i	Input voltage	50	V
V_{ID}	Differential input voltage	50	V
I_O	Output current	1	A
P_{tot}	Power dissipation ($T_A = +25^\circ\text{C}$)	Internally Limited	W
T_{oper}	Operating Free-air Temperature Range	- 25 to + 85	$^\circ\text{C}$
T_{STG}	Storage temperature range	- 65 to + 150	$^\circ\text{C}$

1. 60V, $t \leq 10\text{ms}$

1.2 Thermal data

Table 2. Thermal data

Symbol	Description	Value	Unit
R_{thJA}	Thermal Resistance Junction-ambient	120	$^\circ\text{C}/\text{W}$
R_{thJC}	Thermal Resistance Junction-case	50	$^\circ\text{C}/\text{W}$
R_{th}	Junction-ceramic Substrate (case glued to substrate) SO14	90	$^\circ\text{C}/\text{W}$
R_{th}	Junction-ceramic Substrate (case glued to substrate, substrate temperature maintained constant) SO14	65	$^\circ\text{C}/\text{W}$

2 Electrical characteristics

$T_J = -25$ to $+85^\circ\text{C}$, $V_{CC} = 8$ to 45 V, unless otherwise specified (note 1)

Table 3. Electrical characteristics

Symbol	Parameter	Min	Typ	Max	Unit
V_{IO}	Input offset voltage ⁽²⁾	–	2	50	mV
I_{IB}	Input bias current	–	0.1	1.5	mA
I_{CC}	Supply Current ($V_{CC} = +24\text{V}$, $I_O = 0$)				
	High level	–	4	6	mA
	Low level	–	2	4	mA
$V_{I(\text{max})}$	Common-mode input voltage range	2	–	$V_{CC}-2$	V
I_{SC}	Short-circuit Current Limit ($T_A = 25^\circ\text{C}$, $V_{CC} = +24\text{V}$)				
	$R_{SC} = 1.5\Omega$	–	480	–	mA
	$R_{SC} = \infty$	–	35	50	mA
$V_{CC}-V_O$	Output saturation voltage (output low)				
	($V_I^+ - V_I^- \geq 50\text{mV}$, $R_{SC} = 0$, $I_O = 300\text{mA}$,)				
	$T_J = +25^\circ\text{C}$	–	1.15	1.4	V
	$T_A = +25^\circ\text{C}$	–	1.05	1.3	V
I_{OL}	Output leakage current (output high)	–	0.01	10	μA
	($V_O = 0$, $V_{CC} = +24\text{V}$, $T_A = +25^\circ\text{C}$)				

1. For operating at high temperature, the TDE1747, must be derated based on a $+150^\circ\text{C}$ maximum junction temperature and junction-ambient thermal resistance of 120°C/W for DIP-8 and 100°C/W for the SO14.
2. The offset voltage given is the maximum value of input voltage required to drive the output voltage within 2V of the ground or the supply voltage.

3 Pin connections and schematic diagrams

Figure 1. Pin connections (top views)

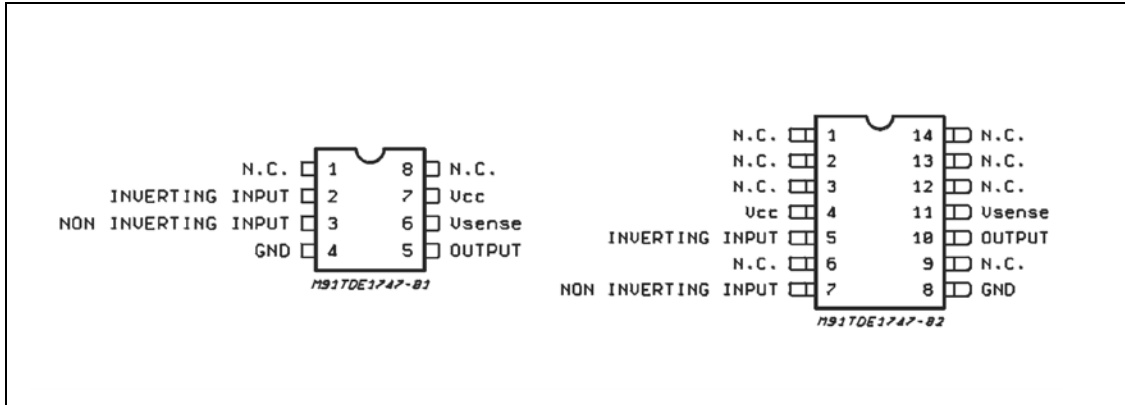

Figure 2. Schematic diagram

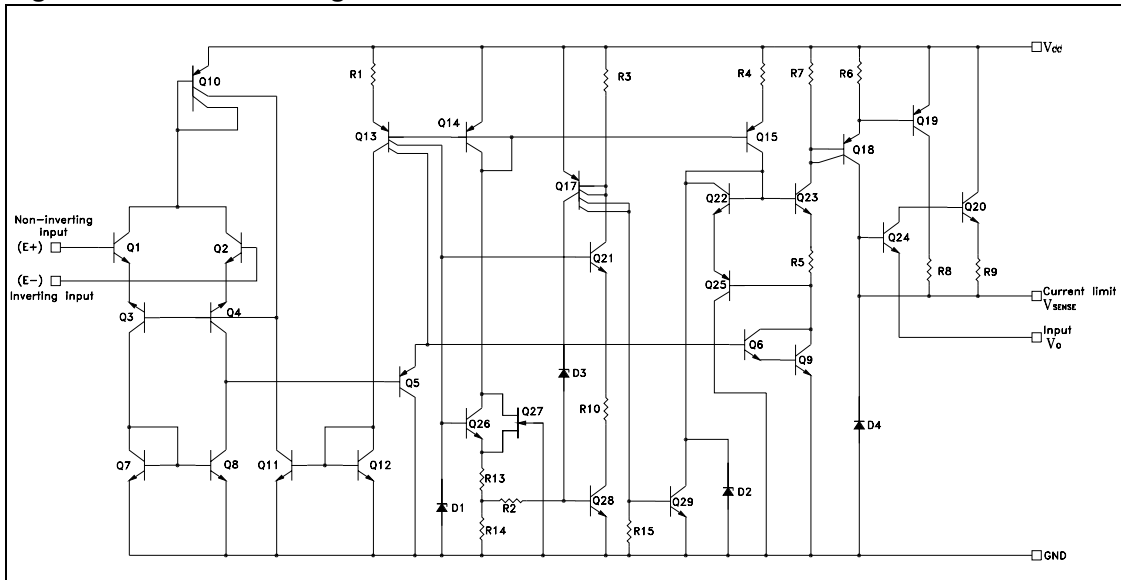

Figure 3. Test circuit

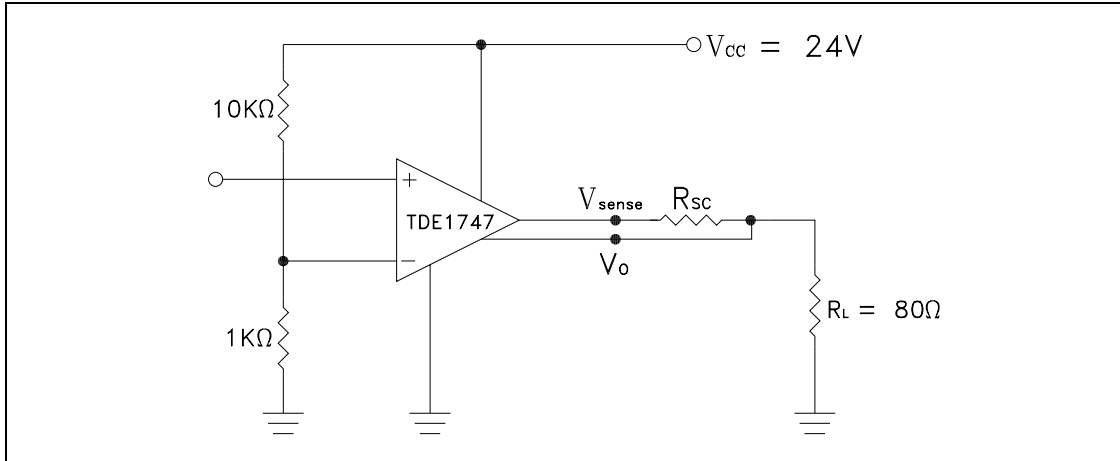
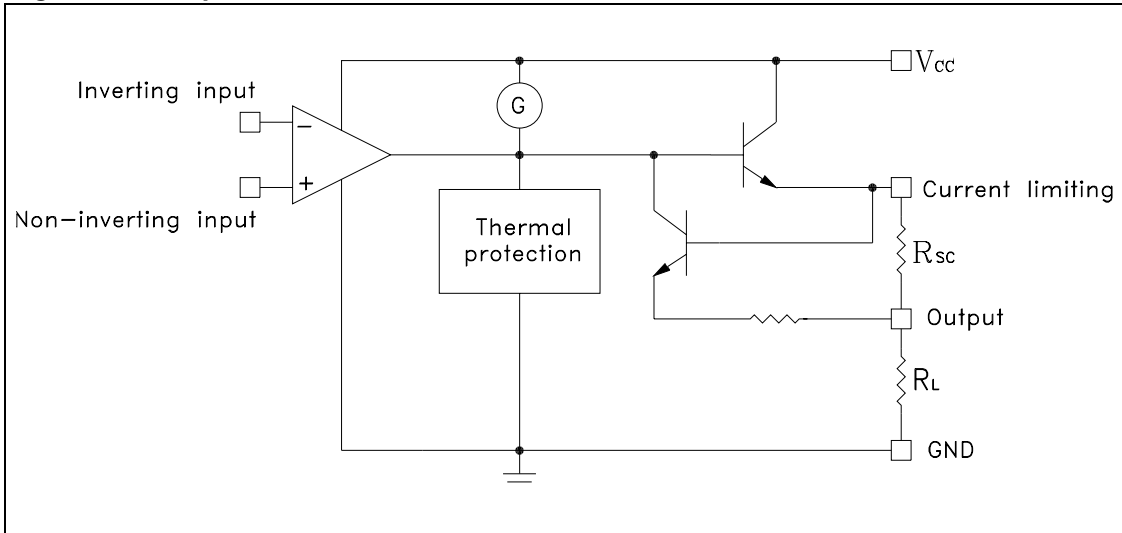

Figure 4. Simplified schematic



4 Typical characteristics

Figure 5. Available output current vs limiting resistors

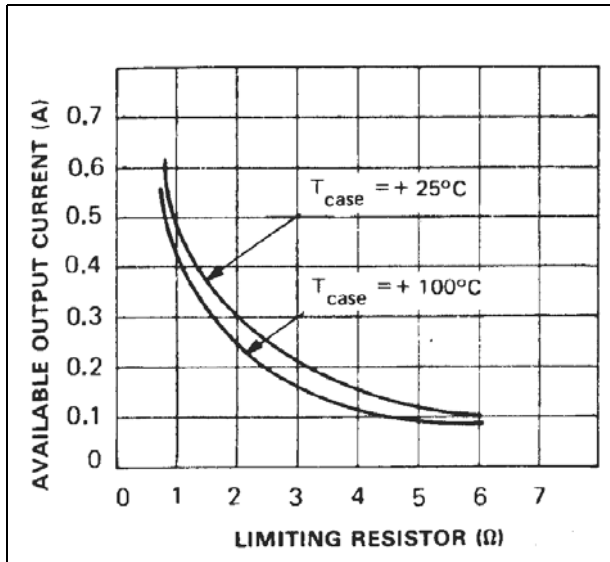

Figure 6. Peak short-circuit vs limiting resistor

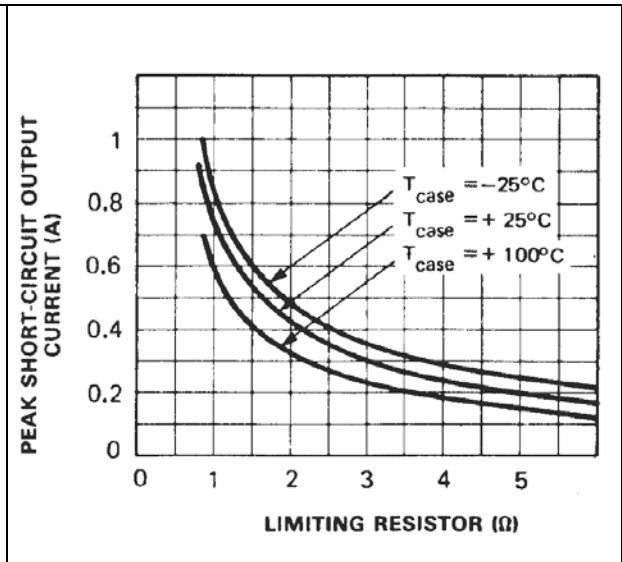

Figure 7. Short-circuit current vs case temperature

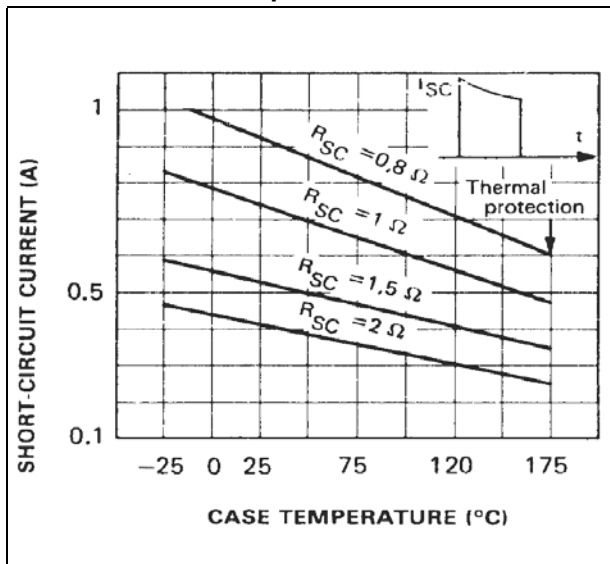

Figure 8. Minimum limiting resistor value vs supply voltage

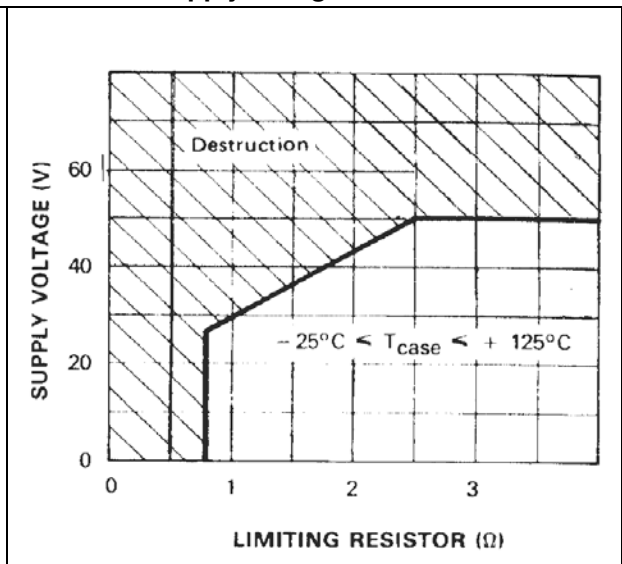

Figure 9. Output current vs output saturation voltage

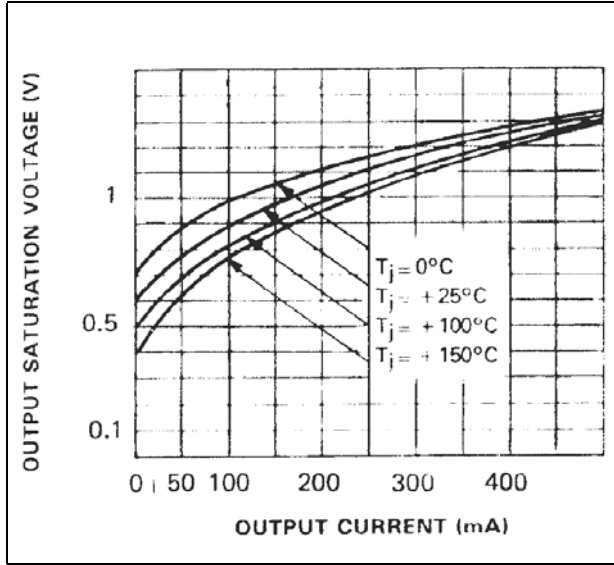

Figure 10. Supply current vs supply voltage

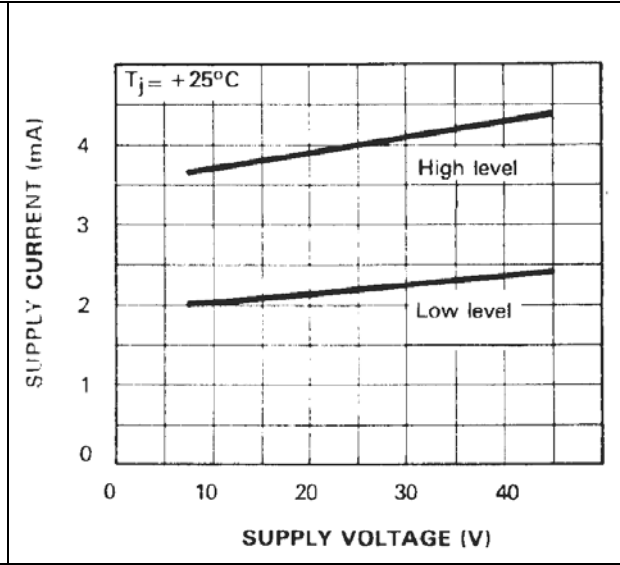

Figure 11. Supply current vs junction temperature

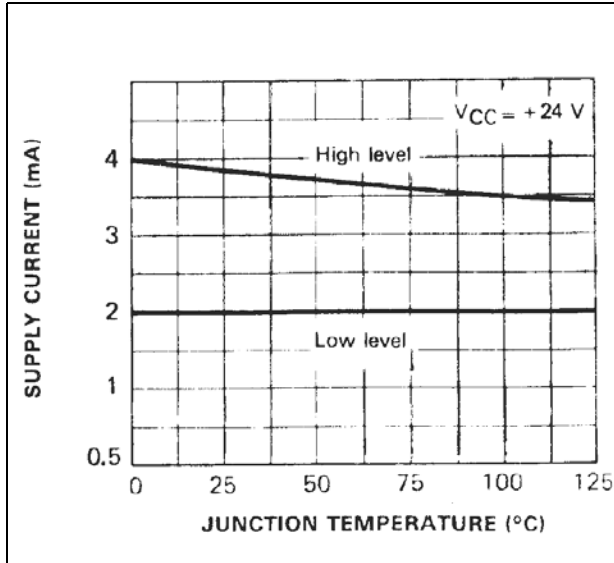

Figure 12. Safe operating area (not repetitive surge)

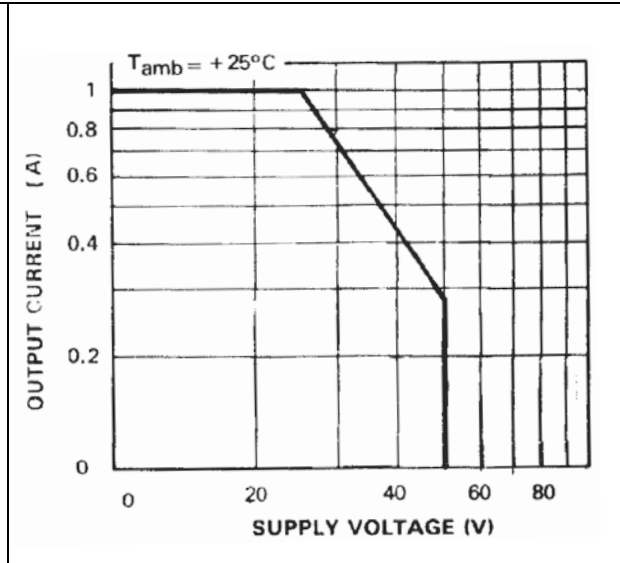
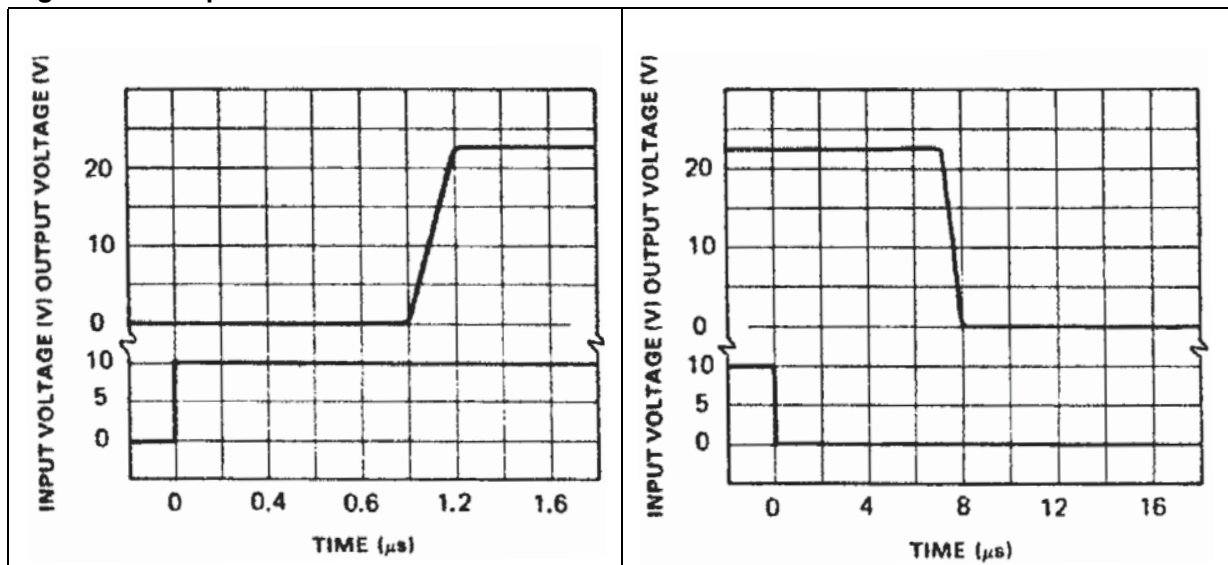

Figure 13. Response time



5 Typical applications

Figure 14. Base circuit

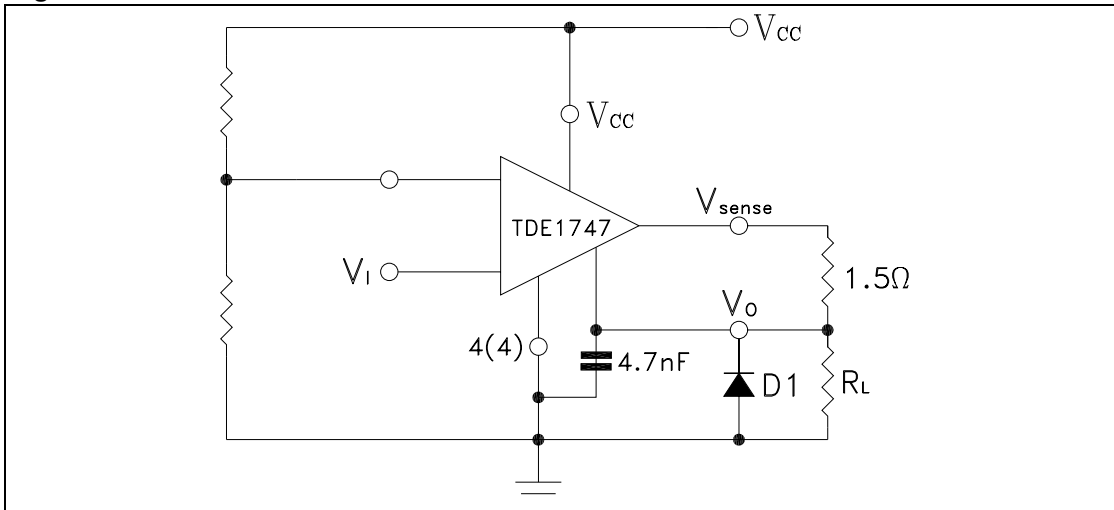

Figure 15. Output current extension (5A)

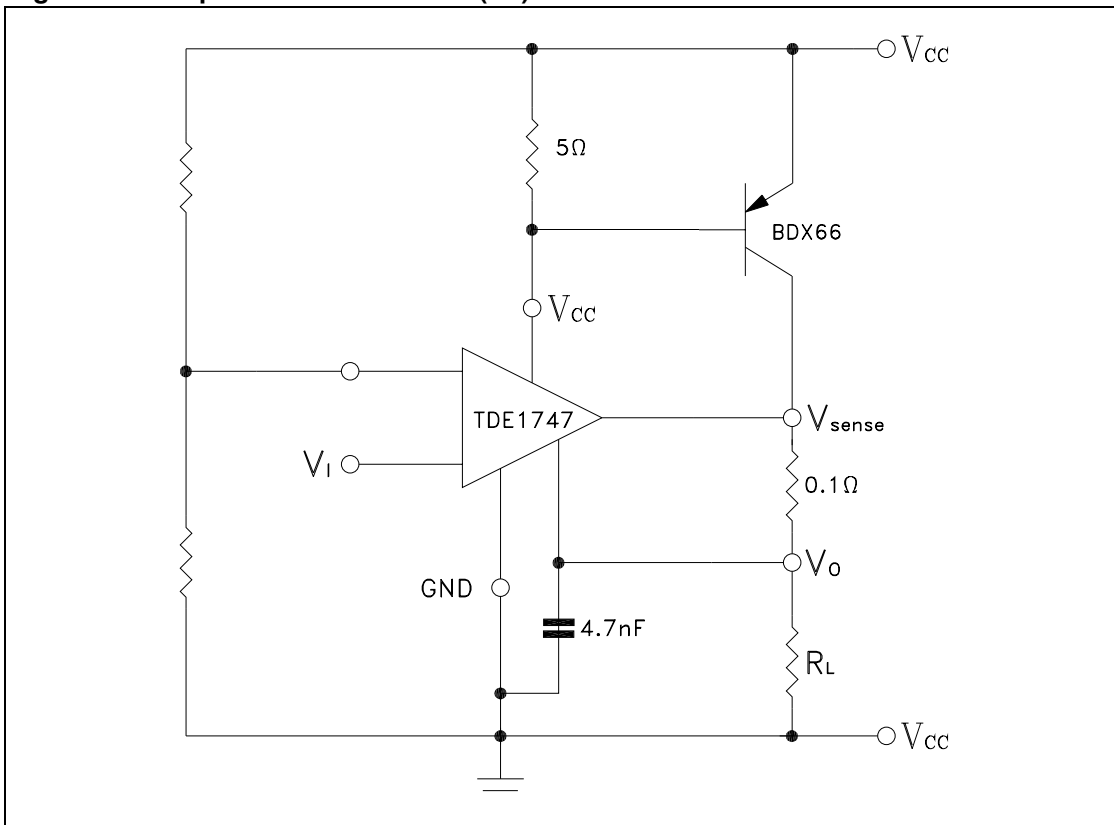
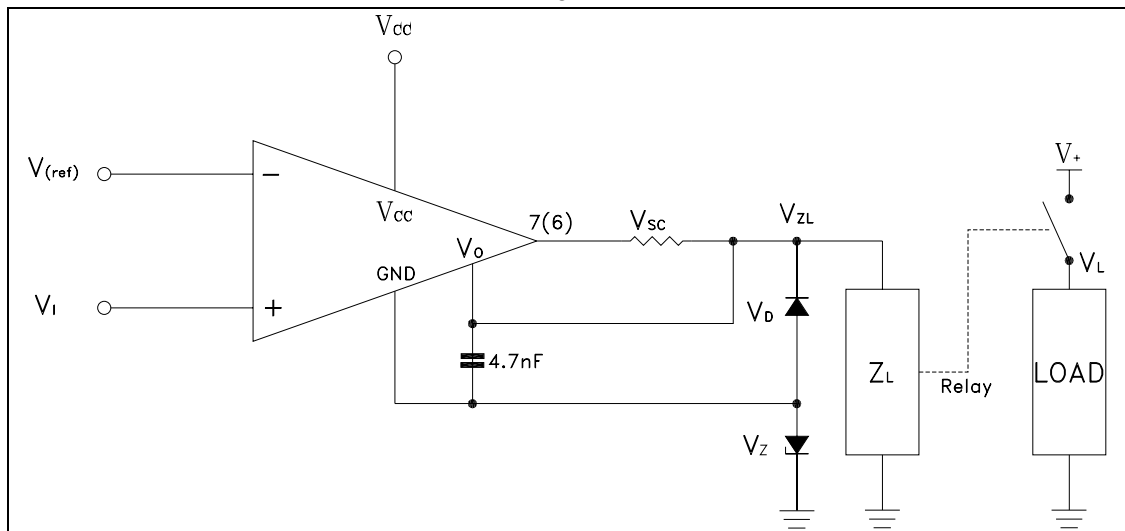

Figure 16. Driving low impedance relays ($I_O = 300\text{mA}$)

6 Waveforms

Figure 17. Input current vs time

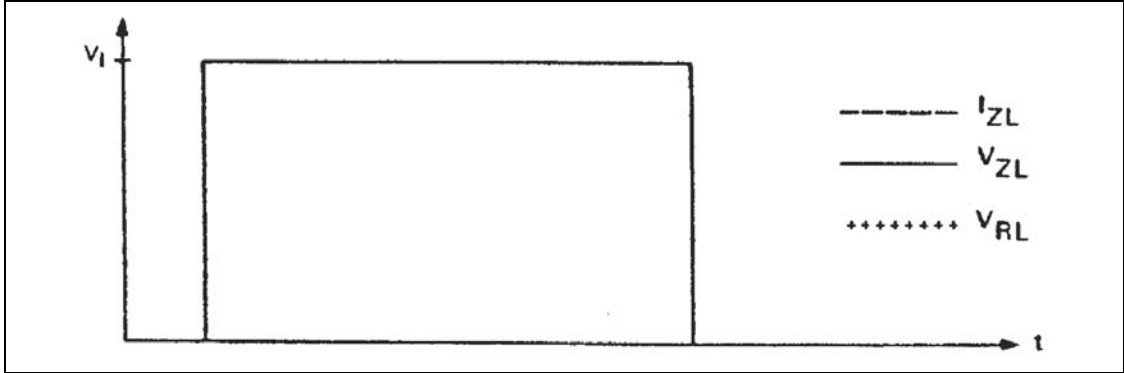

Figure 18. Response time with zener diode

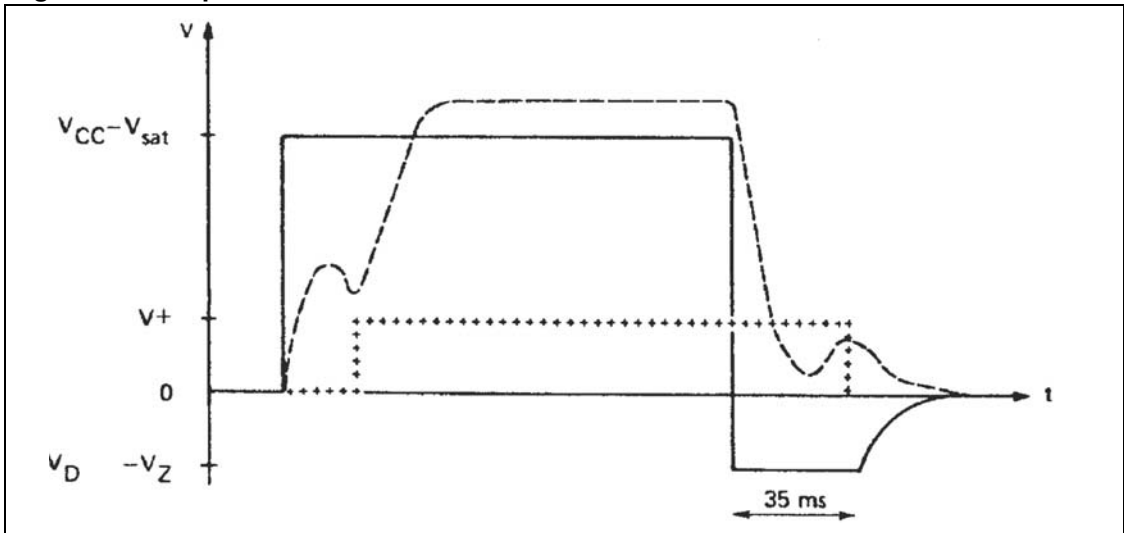
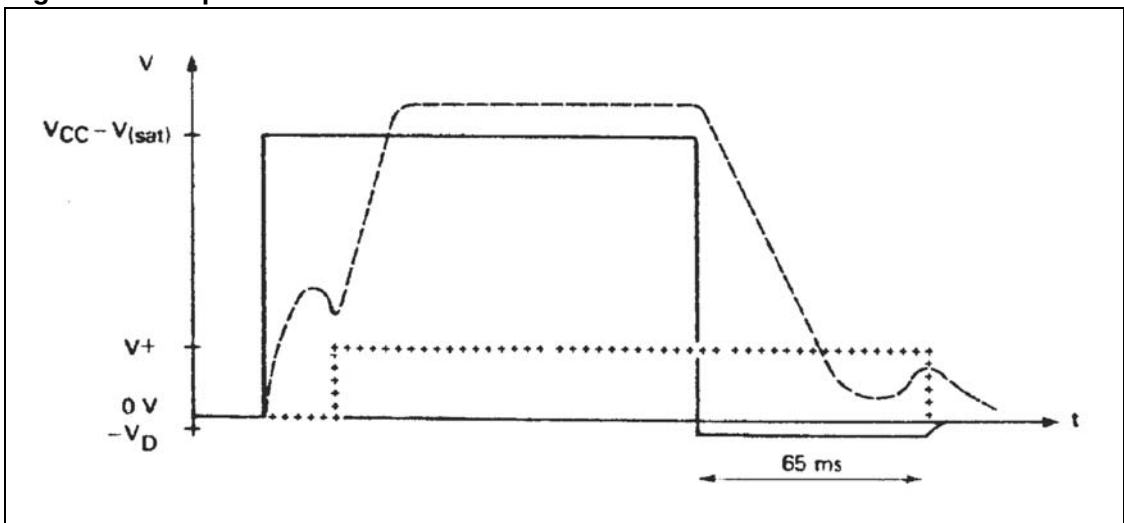

Figure 19. Response time without zener diode



7 Package mechanical data

In order to meet environmental requirements, ST offers these devices in ECOPACK® packages. These packages have a Lead-free second level interconnect. The category of second level interconnect is marked on the package and on the inner box label, in compliance with JEDEC Standard JESD97. The maximum ratings related to soldering conditions are also marked on the inner box label. ECOPACK is an ST trademark. ECOPACK specifications are available at: www.st.com

Table 4. SO14 Mechanical data

Dim.	mm			Inch		
	Min	Typ	Max	Min	Typ	Max
A	1.35		1.75	0.053		0.069
A1	0.10		0.30	0.004		0.012
A2	1.10		1.65	0.043		0.065
B	0.33		0.51	0.013		0.020
C	0.19		0.25	0.007		0.01
D ⁽¹⁾	8.55		8.75	0.337		0.344
E	3.80		4.0	0.150		0.157
e		1.27			0.050	
H	5.8		6.20	0.228		0.244
h	0.25		0.50	0.01		0.02
L	0.40		1.27	0.016		0.050
k	0° (min.), 8° (max.)					
ddd			0.10			0.004

1. "D" dimension does not include mold flash, protusions or gate burrs. Mold flash, protusions or gate burrs shall not exceed 0.15mm per side.

Figure 20. Package dimensions

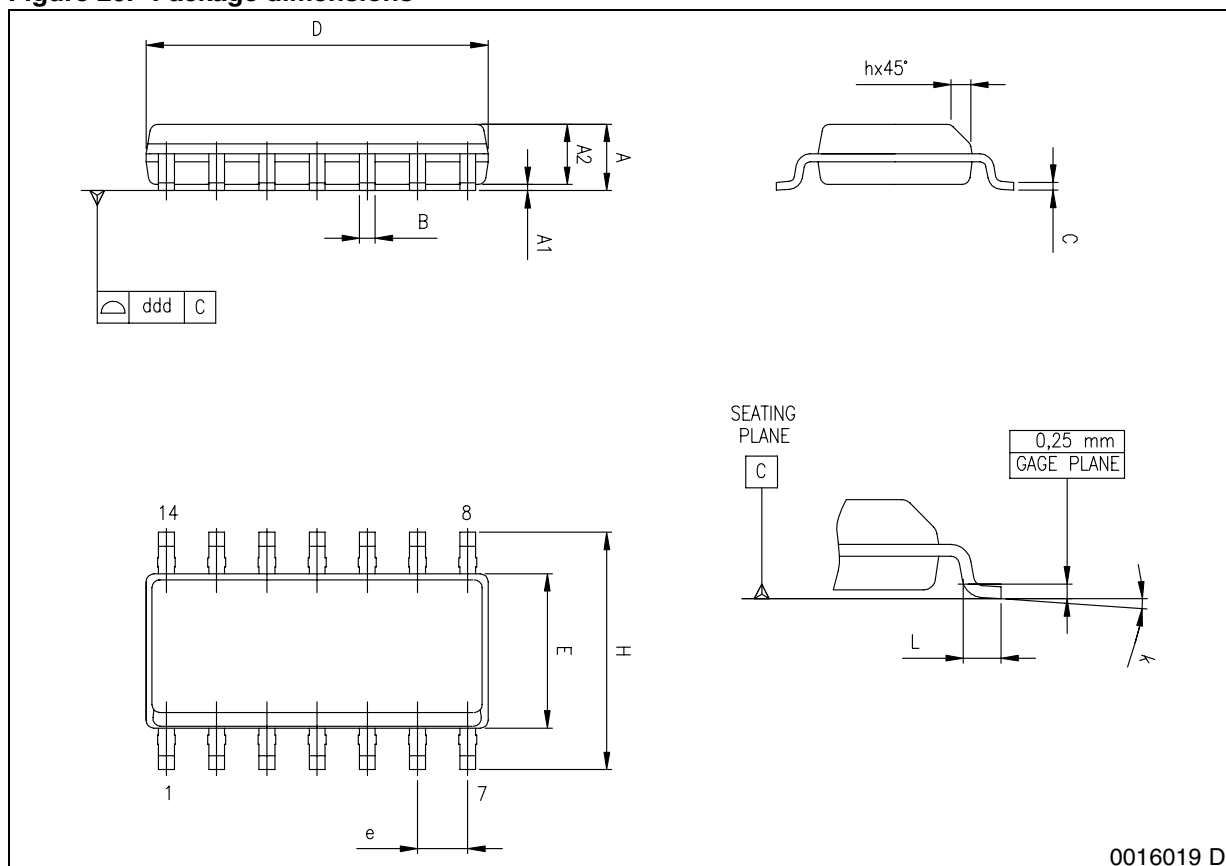
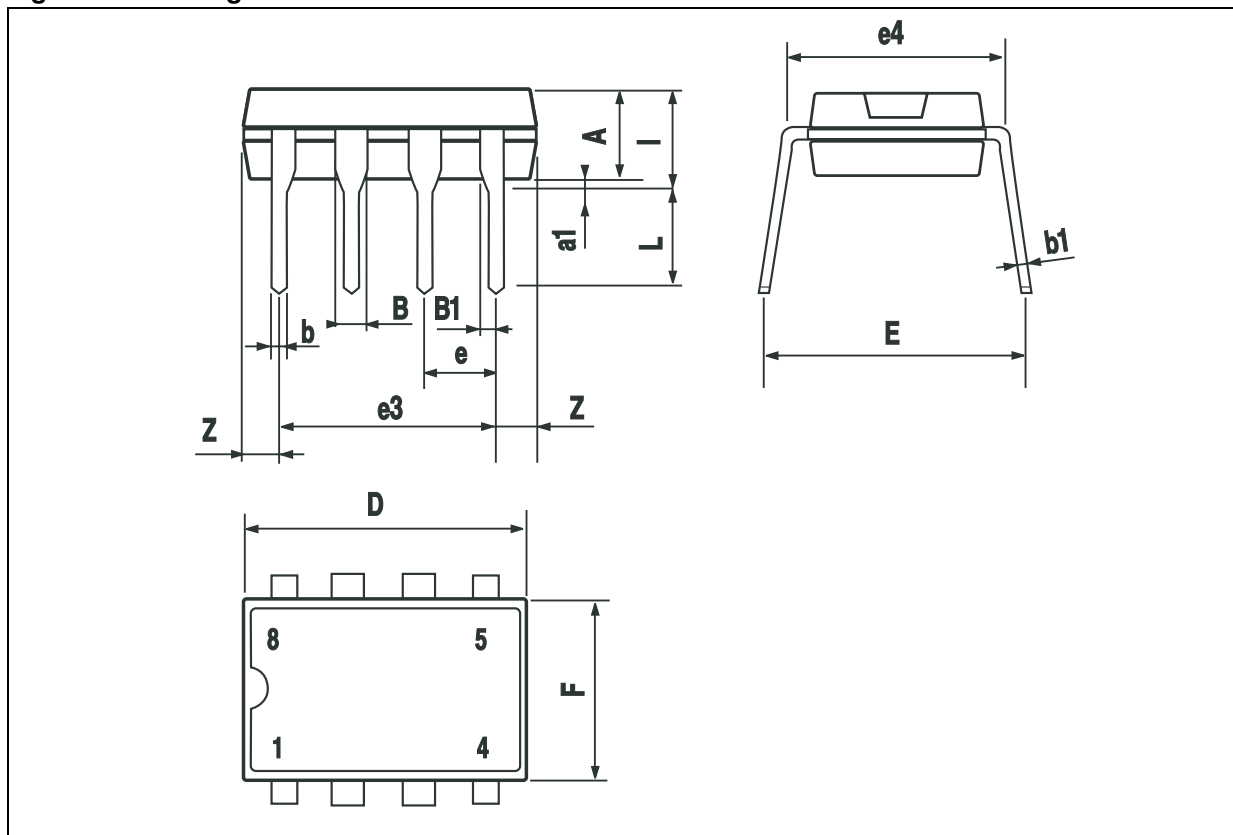

Table 5. DIP-8 Mechanical data

Dim.	mm			Inch		
	Min	Typ	Max	Min	Typ	Max
A		3.32			0.131	
a1	0.51			0.020		
B	1.15		1.65	0.045		0.065
b	0.356		0.55	0.014		0.022
b1	0.204		0.304	0.008		0.012
D			10.92			0.430
E	7.95		9.75	0.313		0.384
e		2.54			0.100	
e3		7.62			0.300	
e4		7.62			0.300	
F			6.6			0.260
I			5.08			0.200
L	3.18		3.81	0.125		0.150
Z			1.52			0.060

Figure 21. Package dimensions



8 Revision history

Table 6. Revision history

Date	Revision	Changes
20-Sep-2006	1	New template

Please Read Carefully:

Information in this document is provided solely in connection with ST products. STMicroelectronics NV and its subsidiaries ("ST") reserve the right to make changes, corrections, modifications or improvements, to this document, and the products and services described herein at any time, without notice.

All ST products are sold pursuant to ST's terms and conditions of sale.

Purchasers are solely responsible for the choice, selection and use of the ST products and services described herein, and ST assumes no liability whatsoever relating to the choice, selection or use of the ST products and services described herein.

No license, express or implied, by estoppel or otherwise, to any intellectual property rights is granted under this document. If any part of this document refers to any third party products or services it shall not be deemed a license grant by ST for the use of such third party products or services, or any intellectual property contained therein or considered as a warranty covering the use in any manner whatsoever of such third party products or services or any intellectual property contained therein.

UNLESS OTHERWISE SET FORTH IN ST'S TERMS AND CONDITIONS OF SALE ST DISCLAIMS ANY EXPRESS OR IMPLIED WARRANTY WITH RESPECT TO THE USE AND/OR SALE OF ST PRODUCTS INCLUDING WITHOUT LIMITATION IMPLIED WARRANTIES OF MERCHANTABILITY, FITNESS FOR A PARTICULAR PURPOSE (AND THEIR EQUIVALENTS UNDER THE LAWS OF ANY JURISDICTION), OR INFRINGEMENT OF ANY PATENT, COPYRIGHT OR OTHER INTELLECTUAL PROPERTY RIGHT.

UNLESS EXPRESSLY APPROVED IN WRITING BY AN AUTHORIZED ST REPRESENTATIVE, ST PRODUCTS ARE NOT RECOMMENDED, AUTHORIZED OR WARRANTED FOR USE IN MILITARY, AIR CRAFT, SPACE, LIFE SAVING, OR LIFE SUSTAINING APPLICATIONS, NOR IN PRODUCTS OR SYSTEMS WHERE FAILURE OR MALFUNCTION MAY RESULT IN PERSONAL INJURY, DEATH, OR SEVERE PROPERTY OR ENVIRONMENTAL DAMAGE. ST PRODUCTS WHICH ARE NOT SPECIFIED AS "AUTOMOTIVE GRADE" MAY ONLY BE USED IN AUTOMOTIVE APPLICATIONS AT USER'S OWN RISK.

Resale of ST products with provisions different from the statements and/or technical features set forth in this document shall immediately void any warranty granted by ST for the ST product or service described herein and shall not create or extend in any manner whatsoever, any liability of ST.

ST and the ST logo are trademarks or registered trademarks of ST in various countries.

Information in this document supersedes and replaces all information previously supplied.

The ST logo is a registered trademark of STMicroelectronics. All other names are the property of their respective owners.

© 2006 STMicroelectronics - All rights reserved

STMicroelectronics group of companies

Australia - Belgium - Brazil - Canada - China - Czech Republic - Finland - France - Germany - Hong Kong - India - Israel - Italy - Japan - Malaysia - Malta - Morocco - Singapore - Spain - Sweden - Switzerland - United Kingdom - United States of America

www.st.com