



# STA015 STA015B STA015T

## MPEG 2.5 LAYER III AUDIO DECODER WITH ADPCM CAPABILITY

PRODUCT PREVIEW

- SINGLE CHIP MPEG LAYER 3 DECODER SUPPORTING:
  - All features specified for Layer III in ISO/IEC 11172-3 (MPEG 1 Audio)
  - All features specified for Layer III in ISO/IEC 13818-3.2 (MPEG 2 Audio)
  - Lower sampling frequencies syntax extension, (not specified by ISO) called MPEG 2.5
- DECODES LAYER III STEREO CHANNELS, DUAL CHANNEL, SINGLE CHANNEL (MONO)
- SUPPORTING ALL THE MPEG 1 & 2 SAMPLING FREQUENCIES AND THE EXTENSION TO MPEG 2.5:  
48, 44.1, 32, 24, 22.05, 16, 12, 11.025, 8 KHz
- ACCEPTS MPEG 2.5 LAYER III ELEMENTARY COMPRESSED BITSTREAM WITH DATA RATE FROM 8 Kbit/s UP TO 320 Kbit/s
- ADPCM CODEC CAPABILITIES:
  - sample frequency from 8 kHz to 32 kHz
  - sample size from 8 bits to 32 bits
  - encoding algorithm: DVI, ITU-G726 pack (G723-24, G721, G723-40)
  - Tone control and fast-forward capability
- EASY PROGRAMMABLE GPSO INTERFACE FOR ENCODED DATA UP TO 5Mbit/s (TQFP44 & LFBGA 64)
- DIGITAL VOLUME
- BASS & TREBLE CONTROL
- BYPASS MODE FOR EXTERNAL AUDIO SOURCE
- SERIAL BITSTREAM INPUT INTERFACE
- EASY PROGRAMMABLE ADC INPUT INTERFACE
- ANCILLARY DATA EXTRACTION VIA I2C INTERFACE.
- SERIAL PCM OUTPUT INTERFACE (I<sup>2</sup>S AND OTHER FORMATS)
- PLL FOR INTERNAL CLOCK AND FOR OUTPUT PCM CLOCK GENERATION
- CRC CHECK AND SYNCHRONISATION ERROR DETECTION WITH SOFTWARE INDICATORS
- I<sup>2</sup>C CONTROL BUS
- LOW POWER 2.4V CMOS TECHNOLOGY
- WIDE RANGE OF EXTERNAL CRYSTALS FREQUENCIES SUPPORTED

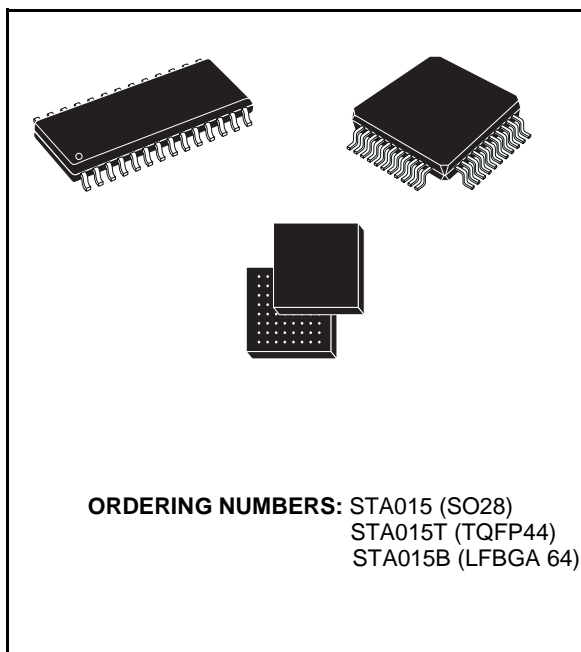

### APPLICATIONS

- PC SOUND CARDS
- MULTIMEDIA PLAYERS
- VOICE RECORDERS

### DESCRIPTION

The STA015 is a fully integrated high flexibility MPEG Layer III Audio Decoder, capable of decoding Layer III compressed elementary streams, as specified in MPEG 1 and MPEG 2 ISO standards. The device decodes also elementary streams compressed by using low sampling rates, as specified by MPEG 2.5.

STA015 receives the input data through a Serial Input Interface. The decoded signal is a stereo, mono, or dual channel digital output that can be sent directly to a D/A converter, by the PCM Output Interface. This interface is software programmable to adapt the STA015 digital output to the most common DACs architectures used on the market.

The functional STA015 chip partitioning is described in Fig.1a and Fig.1b.

Figure 1a. BLOCK DIAGRAM for TQFP44 and LFBGA64 package

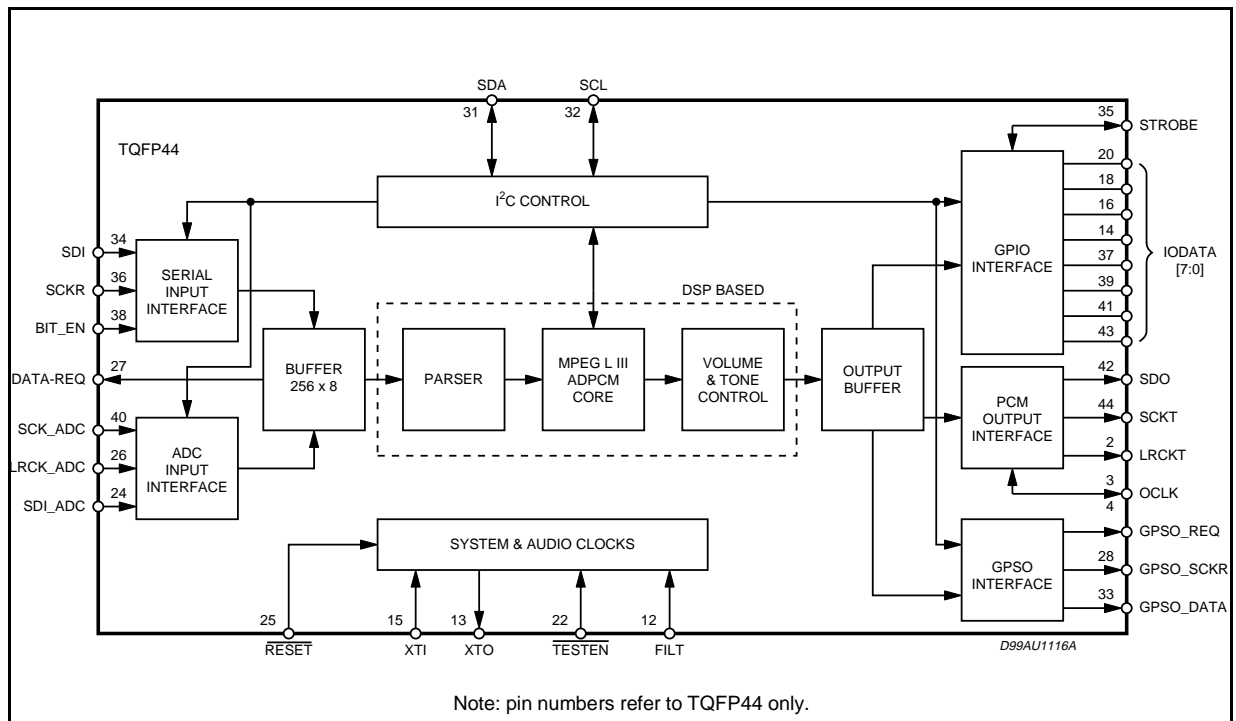

Figure 1b. BLOCK DIAGRAM for SO28 package

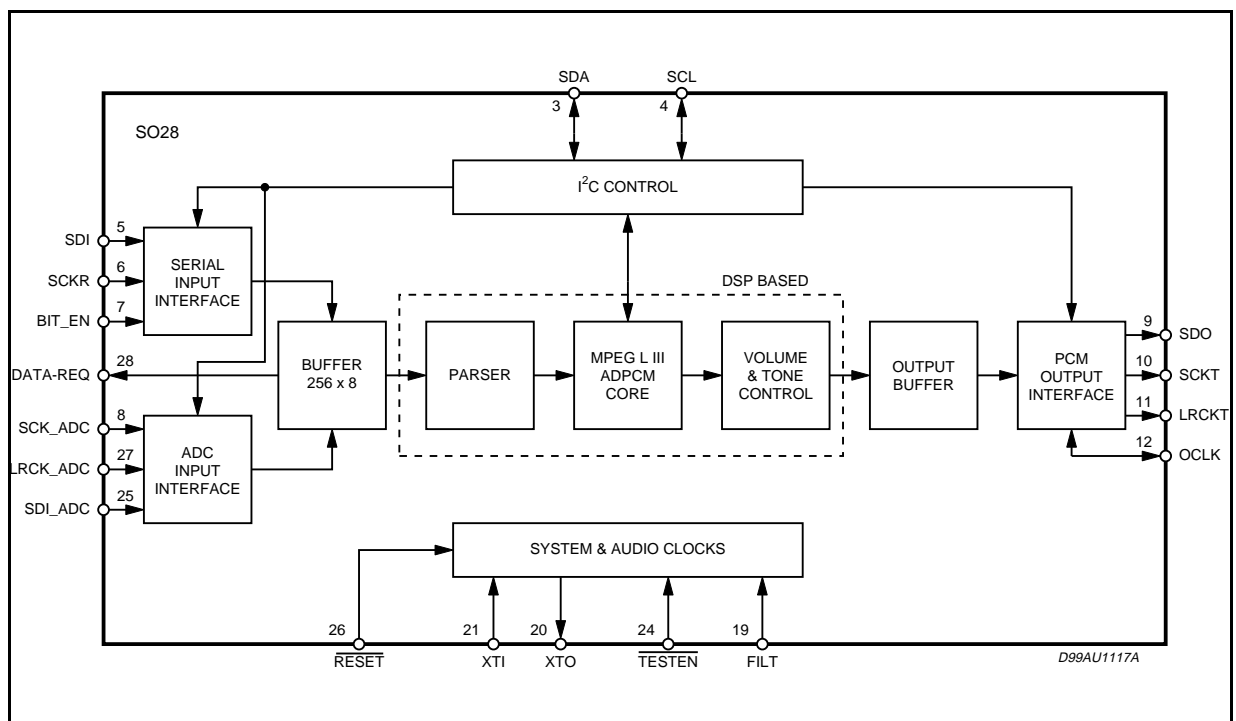
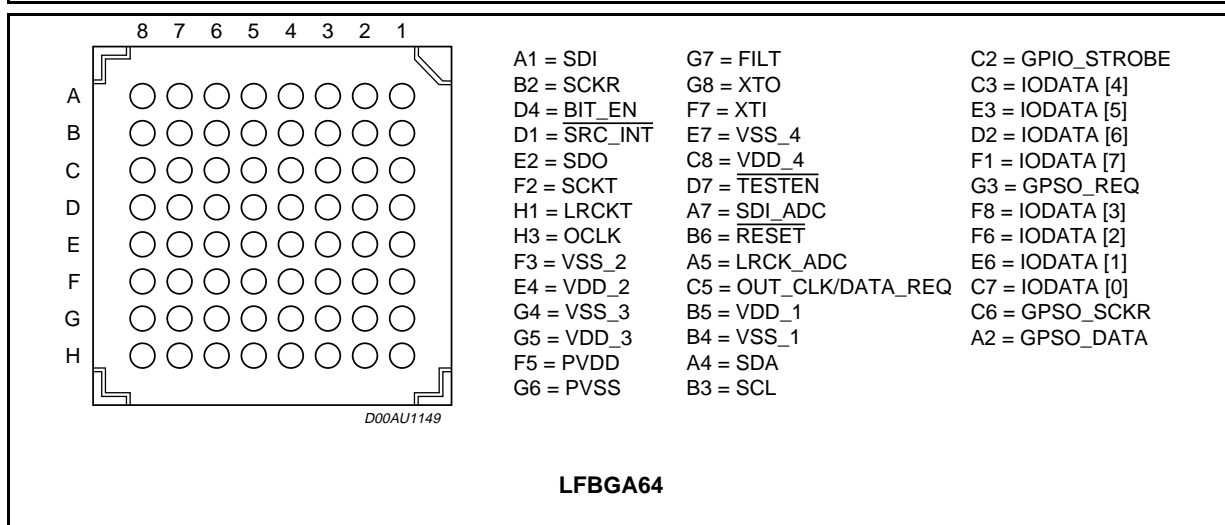
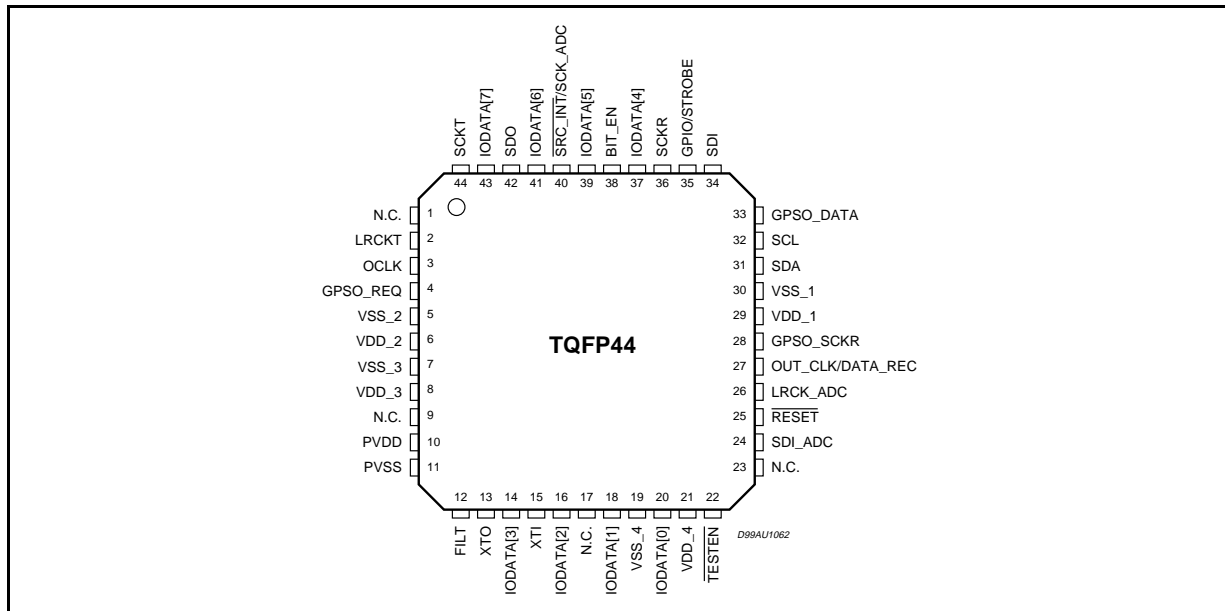
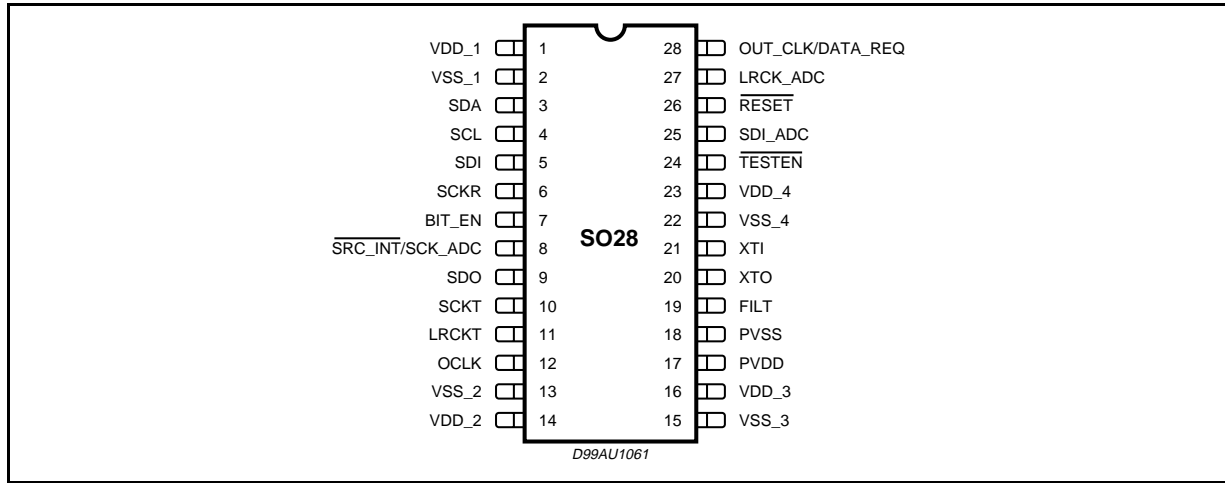

Figure 2. PIN CONNECTIONS



**1. OVERVIEW**

**1.1 - MP3 decoder engine**

The MP3 decoder engine is able to decode any Layer III compliant bitstream: MPEG1, MPEG2 and MPEG2.5 streams are supported. Besides audio data decoding the MP3 engine also performs ANCILLARY data extraction: these data can be retrieved via I2C bus by the application microcontroller in order to implement specific functions.

Decoded audio data goes through a software volume control and a two-band equalizer blocks before feeding the output I2S interface. This results in no need for an external audio processor.

MP3 bitstream is sent to the decoder using a simple serial input interface (see pins SDI, SCKR, BIT\_EN and DATA\_REQ), supporting input rate up to 20 Mbit/s. Received data are stored in a 256 bytes long input buffer which provides a feedback line (see DATA\_REQ pin) to the bitstream source (typically an MCU).

**1.2 - ADPCM encoder/decoder engine**

This device also embeds a multistandard ADPCM encoder/decoder supporting different sample

rates (from 8 KHz up to 32 KHz) and different sample sizes (from 8 bit to 32 bits).

During encoding process two different interfaces can be used to feed data: the serial input interface (same interface used also to feed MP3 bitstream) or the ADC input interface, which provides a seamless connection with an external A/D converter.

The currently used interface is selected via I2C bus.

Also to retrieve encoded data two different interfaces are available: the I2C bus or the faster GPSO output interface. GPSO interface is able to output data with a bitrate up to 5 Mbit/s and its control pins (GPSO\_SCKR, GPSO\_DATA and GPSO\_REQ) can be configured in order to easily fit the target application.

**1.3 - BYPASS functional mode**

In order to allow using the device to post-process auxiliary audio sources a special BYPASS mode is available.

When the device is configured in BYPASS mode the embedded DSP will process digital audio data coming through the ADC input interface and will output the resulting data to the external DAC. Available processings include volume and a tone controls.

**ABSOLUTE MAXIMUM RATINGS**

Symbol	Parameter	Value	Unit
V <sub>DD</sub>	Power Supply	-0.3 to 4	V
V <sub>i</sub>	Voltage on Input pins	-0.3 to V <sub>DD</sub> +0.3	V
V <sub>O</sub>	Voltage on output pins	-0.3 to V <sub>DD</sub> +0.3	V
T <sub>stg</sub>	Storage Temperature	-40 to +150	°C
T <sub>oper</sub>	Operative ambient temp	-20 to +85	°C

**THERMAL DATA**

Symbol	Parameter	Value	Unit
R <sub>th j-amb</sub>	Thermal resistance Junction to Ambient	85	°C/W

**PIN DESCRIPTION**

SO28	TQFP44	LFBGA64	Pin Name	Type	Function	PAD Description
1	29	B5	VDD_1		Supply Voltage	
2	30	B4	VSS_1		Ground	
3	31	A4	SDA	I/O	I <sup>2</sup> C Serial Data + Acknowledge	CMOS Input Pad Buffer CMOS 4mA Output Drive
4	32	B3	SCL	I	I <sup>2</sup> C Serial Clock	CMOS Input Pad Buffer
5	34	A1	SDI	I	Receiver Serial Data	CMOS Input Pad Buffer
6	36	B2	SCKR	I	Receiver Serial Clock	CMOS Input Pad Buffer
7	38	D4	BIT_EN	I	Bit Enable	CMOS Input Pad Buffer with pull up
8	40	D1	SRC_INT/SCK_ADC	I	Interrupt Line/ADC Serial Clock	CMOS Input Pad Buffer
9	42	E2	SDO	O	Transmitter Serial Data (PCM Data)	CMOS 4mA Output Drive
10	44	F2	SCKT	O	Transmitter Serial Clock	CMOS 4mA Output Drive
11	2	H1	LRCLKT	O	Transmitter Left/Right Clock	CMOS 4mA Output Drive
12	3	H3	OCLK	I/O	Oversampling Clock for DAC	CMOS Input Pad Buffer CMOS 4mA Output Drive
13	5	F3	VSS_2		Ground	
14	6	E4	VDD_2		Supply Voltage	
15	7	G4	VSS_3		Ground	
16	8	G5	VDD_3		Supply Voltage	
17	10	F5	PVDD		PLL Power	
18	11	G6	PVSS		PLL Ground	
19	12	G7	FILT	O	PLL Filter Ext. Capacitor Conn.	
20	13	G8	XTO	O	Crystal Output	CMOS 4mA Output Drive
21	15	F7	XTI	I	Crystal Input (Clock Input)	Specific Level Input Pad (see paragraph 2.1)
22	19	E7	VSS_4		Ground	
23	21	C8	VDD_4		Supply Voltage	
24	22	D7	TESTEN	I	Test Enable	CMOS Input Pad Buffer with pull up
25	24	A7	SDI_ADC	I	ADC Data Input	CMOS Input Pad Buffer
26	25	B6	RESET	I	System Reset	CMOS Input Pad Buffer with pull up
27	26	A5	LRCK_ADC	I	ADC Left/Right Clock	CMOS Output Pad Buffer
28	27	C5	OUT_CLK/ DATA_REQ	O	Buffered Output Clock/ Data Request Signal	CMOS 4mA Output Drive
	20	C7	IODATA[0]	I/O	GPIO Data Line	CMOS 4mA Schmitt Trigger Bidir Pad Buffer
	18	E6	IODATA[1]	I/O	GPIO Data Line	
	16	F6	IODATA[2]	I/O	GPIO Data Line	
	14	F8	IODATA[3]	I/O	GPIO Data Line	
	37	C3	IODATA[4]	I/O	GPIO Data Line	
	39	E3	IODATA[5]	I/O	GPIO Data Line	
	41	D2	IODATA[6]	I/O	GPIO Data Line	
	43	F1	IODATA[7]	I/O	GPIO Data Line	
	35	C2	GPIO_STROBE	I/O	GPIO Strobe Signal	
	4	G3	GPSO_REQ	O	GPSO Request Signal	
	28	C6	GPSO_SCKR	I	GPSO Serial Clock	CMOS Input Pad Buffer
	33	A2	GPSO_DATA	O	GPSO Serial Data	CMOS Output Pad Buffer

Note: In functional mode TESTEN must be connected to VDD.

**1. ELECTRICAL CHARACTERISTICS:**  $V_{DD} = 3.3V \pm 0.3V$ ;  $T_{amb} = 0$  to  $70^{\circ}C$ ;  $R_g = 50\Omega$  unless otherwise specified

**DC OPERATING CONDITIONS**

Symbol	Parameter	Value
$V_{DD}$	Power Supply Voltage	2.4 to 3.6V
$T_j$	Operating Junction Temperature	-20 to 125°C

**GENERAL INTERFACE ELECTRICAL CHARACTERISTICS**

Symbol	Parameter	Test Condition	Min.	Typ.	Max.	Unit	Note
$I_{iL}$	Low Level Input Current Without pull-up device	$V_i = 0V$	-10		10	$\mu A$	1
$I_{iH}$	High Level Input Current Without pull-up device	$V_i = V_{DD}$	-10		10	$\mu A$	1
$V_{esd}$	Electrostatic Protection	Leakage $< 1\mu A$	2000			V	2

**Note 1:** The leakage currents are generally very small,  $< 1nA$ . The value given here is a maximum that can occur after an electrostatic stress on the pin.

**Note 2:** Human Body Model.

**DC ELECTRICAL CHARACTERISTICS**

Symbol	Parameter	Test Condition	Min.	Typ.	Max.	Unit	Note
$V_{iL}$	Low Level Input Voltage				$0.2 \cdot V_{DD}$	V	
$V_{iH}$	High Level Input Voltage		$0.8 \cdot V_{DD}$			V	
$V_{oL}$	Low Level Output Voltage	$I_{oL} = Xma$			0.4V	V	1, 2
$V_{oH}$	High Level Output Voltage		$0.85 \cdot V_{DD}$			V	1, 2

**Note 1:** Takes into account 200mV voltage drop in both supply lines.

**Note 2:** X is the source/sink current under worst case conditions and is reflected in the name of the I/O cell according to the drive capability.

Symbol	Parameter	Test Condition	Min.	Typ.	Max.	Unit	Note
$I_{pu}$	Pull-up current	$V_i = 0V$ ; pin numbers 7, 24 and 26	-25	-66	-125	$\mu A$	1
$R_{pu}$	Equivalent Pull-up Resistance			50		$k\Omega$	

**Note 1:** Min. condition:  $V_{DD} = 2.7V$ ,  $125^{\circ}C$  Min process  
 Max. condition:  $V_{DD} = 3.6V$ ,  $-20^{\circ}C$  Max.

**POWER DISSIPATION**

Symbol	Parameter	Test Condition	Min.	Typ.	Max.	Unit	Note
PD	Power Dissipation @ $V_{DD} = 2.4V$	Sampling_freq $\leq 24$ kHz		76		mW	
		Sampling_freq $\leq 32$ kHz		79		mW	
		Sampling_freq $\leq 48$ kHz		85		mW	

Figure 3. Test Circuit (refer to SO28 package)

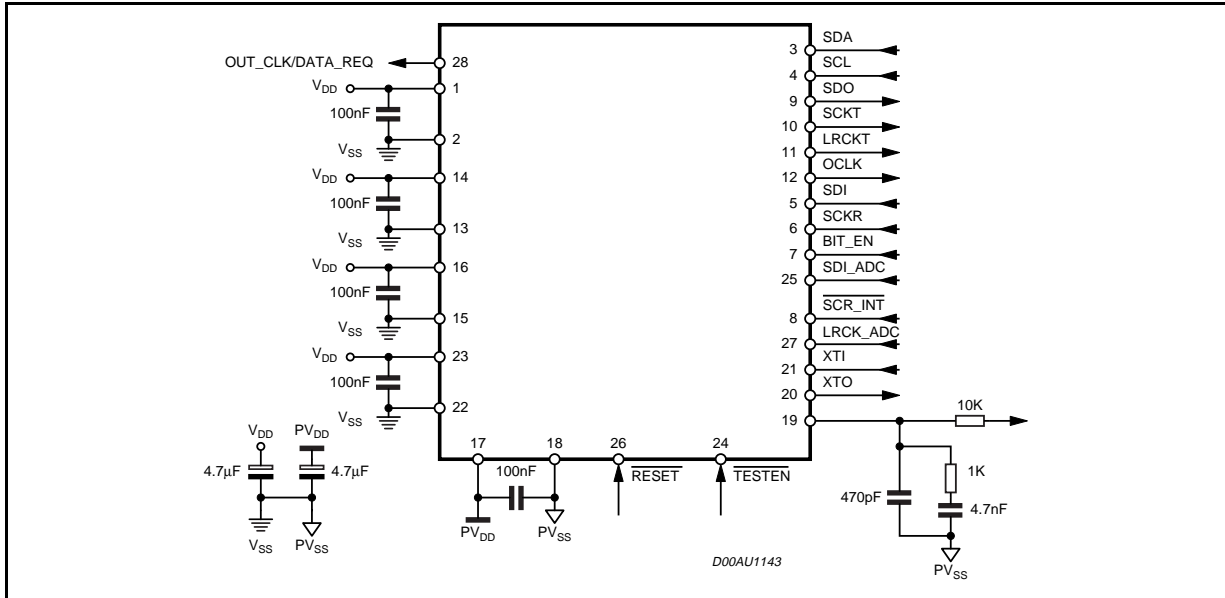
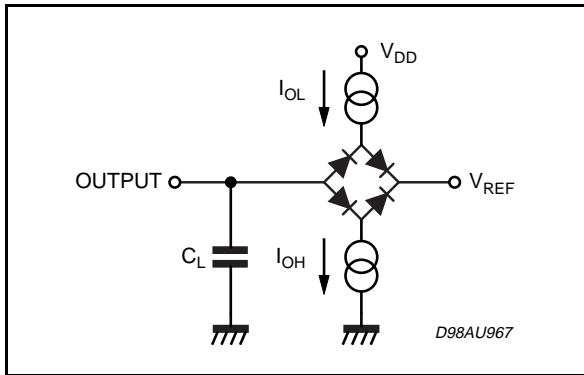

Figure 4. Test Load Circuit



Test Load

Output	I <sub>OL</sub>	I <sub>OH</sub>	C <sub>L</sub>	V <sub>REF</sub>
SDA	1mA		100pF	3.6V
Other Outputs	100μA	100μA	100pF	1.5V

## 2. FUNCTIONAL DESCRIPTION

### 2.1 - Clock Signal

The STA015 input clock is derived from an external source or from a industry standard crystal oscillator, generating input frequencies of 10, 14.31818 or 14.7456 MHz.

Other frequencies may be supported upon request to STMicroelectronics. Each frequency is supported by downloading a specific configuration file, provided by STM

XTI is an input Pad with specific levels.

Symbol	Parameter	Test Condition	Min.	Typ.	Max.	Unit
V <sub>IL</sub>	Low Level Input Voltage				V <sub>DD</sub> -1.8	V
V <sub>IH</sub>	High Level Input Voltage		V <sub>DD</sub> -0.8			V

#### CMOS compatibility

The XTI pad low and high levels are CMOS compatible; XTI pad noise margin is better than typical CMOS pads.

#### TTL compatibility

The XTI pad low level is compatible with TTL while the high level is not compatible (for example if V<sub>DD</sub> = 3V TTL min high level = 2.0V while XTI min high level = 2.2V)

Figure 5. PLL and Clocks Generation System

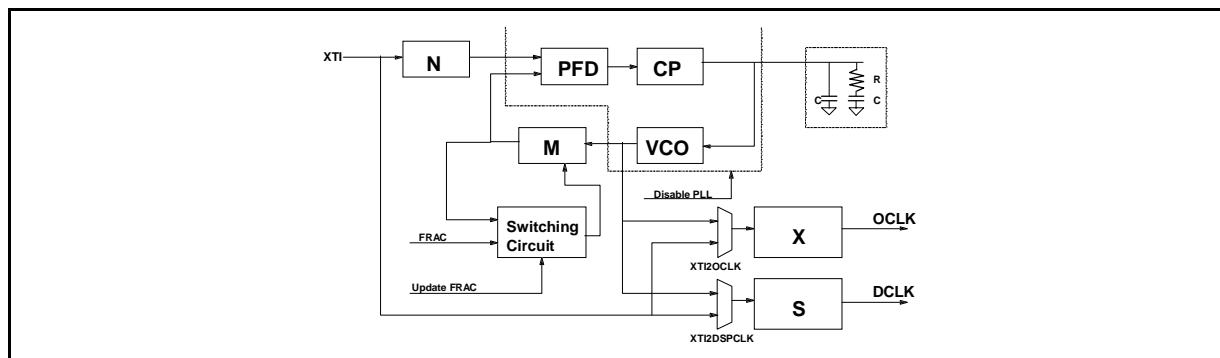

### 2.2 - PLL & Clock Generator System

When STA015 receives the input clock, as described in Section 2.1, and a valid layer III input bitstream, the internal PLL locks, providing to the DSP Core the master clock (DCLK), and to the Audio Output Interface the nominal frequencies of the incoming compressed bit stream. The STA015 PLL block diagram is described in Figure 5.

The audio sample rates are obtained dividing the oversampling clock (OCLK) by software programmable factors. The operation is done by STA015 embedded software and it is transparent to the user.

The STA015 PLL can drive directly most of the commercial DACs families, providing an over sampling clock, OCLK, obtained dividing the VCO frequency with a software programmable dividers.

### 2.3 - STA015 Operational Modes

The device can be configured in 4 different operational modes. To select one specific mode a dedicated CHIP\_MODE registers is available. For proper operation the following steps must be issued to switch between different modes:

- issue a software reset (SOFT\_RESET register)
- select the desired mode (CHIP\_MODE register)
- run the device (RUN register)

Hereby is a short description of each available mode

#### ■ ADPCM Encoder

This mode can be used to encode the incoming bitstream with 4 different compression algorithms. Moreover different sample frequencies and word size are supported. For a detailed description of this features refer to the related registers.

#### ■ ADPCM Decoder

This mode can be used when an ADPCM compressed bitstream must be decoded.

The input interface handling and control flow is the same as in the MP3 Mode.

#### ■ BYPASS mode

Using this mode it's possible to use the embedded post-processing controls (volume and tone controls) to process an incoming uncompressed stereo audio stream. In this configuration ADC input is the only supported interface. This could be useful, for instance, to process audio data coming from an external tuner or some other auxiliary source.

#### ■ MP3 mode

In MP3 Mode (default mode) STA015 decodes the incoming bitstream, acting as a master of the data communication from the source to itself.

This control is done by a specific buffer management, controlled by STA015 embedded software. The data coming from the serial interface are stored in the input buffer, a 256 bytes long FIFO.

The feedback line DATA\_REQ actually is the result of the h/w comparison between the writing address of the FIFO and the constant value 252. This means that if the buffer is filled up with more than 252 bytes the DATA\_REQ line goes low, requesting MCU to stop transmission: the maximum time to stop transmitting is given by the time required to transmit 4 bytes (this time, in turn, depends on the bit-stream speed used to send MP3 data).

The input interface can receive data with a speed up to 20Mbit/s. The speed at which the FIFO is emptied is equal to the MP3 nominal bitrate. Provided the FIFO is filled up with 252 bytes the time required to empty it (in worst condition, which is 320kbit/s mpeg stream) is about 6ms. So if no more data is received in this time the buffer will be emptied and this will badly affect the output audio.



In this mode the fractional part of the PLL is disabled and the audio clocks are generated at nominal rates. Fig. 6 describes the default DATA\_REQ signal behaviour. Programming STA015 it is possible to invert the polarity of the DATA\_REQ line (register REQ\_POL).

In order to allow proper operation of the device in broadcast applications a special BROADCAST MP3 decoding mode is available. When configured in BROADCAST mode the device will operate as a slave decoder and no more feedback will be generated to the data source. The output PCM clock will be automatically adjusted by the embedded DSP in order to follow the incoming bit-stream rate and to avoid input buffer under-run/overflow. A special configuration file must be used to enable this operational mode: the file must be downloaded via I2C link after device power-on. Please contact your local ST branch to have more information about.

Figure 6. DATA\_REQ control line

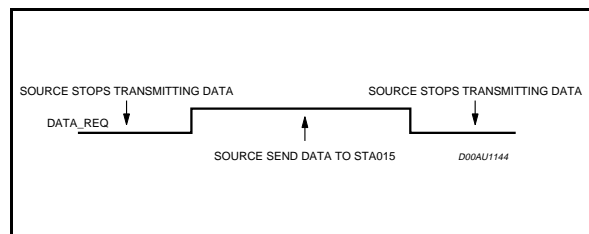

2.4 - STA015 Decoding States

There are three different decoder states: **Idle**, **Init**, and **Decode**. Commands to change the de-

coding states are described in the STA015 I<sup>2</sup>C registers description.

Idle Mode

In this mode (entered after a S/W or H/W reset) the decoder is waiting for the RUN command. This mode should be used to initialize the configuration registers of the device. The DAC connected to STA015 can be initialized during this mode (set MUTE to 1).

PLAY	MUTE	Clock State	PCM Output
X	0	Not Running	0
X	1	Running	0

Init Mode

"PLAY" and "MUTE" changes are ignored in this mode. The internal state of the decoder will be updated only when the decoder changes from the state "init" to the state "decode". The "init" phase ends when the first decoded samples are at the output stage of the device.

Decode Mode

This mode is completely described by the following table:

PLAY	MUTE	Clock State	PCM Output	Decoding
0	0	Not Running	0	No
0	1	Running	0	No
1	0	Running	Decoded Samples	Yes
1	1	Running	0	Yes

Figure 7. MPEG Decoder Interfaces.

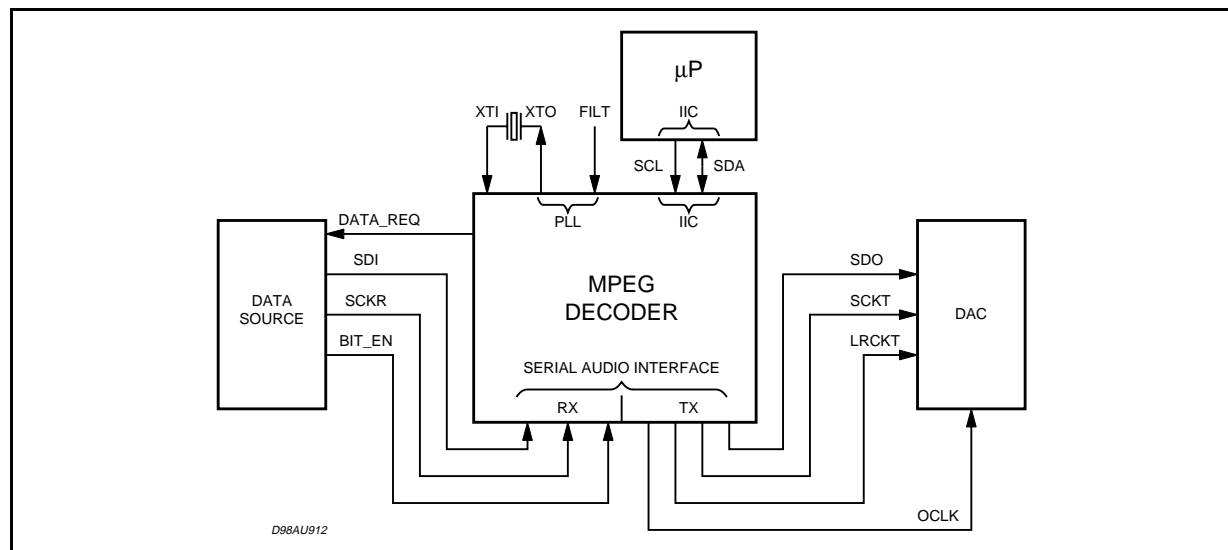
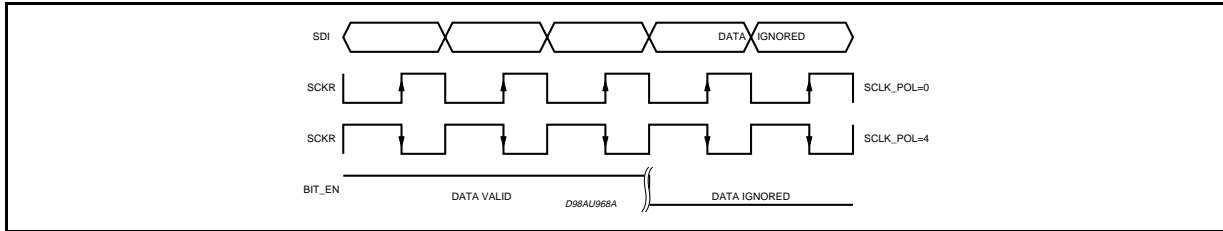

Figure 8. Serial Input Interface Clocks



3. INTERFACE DESCRIPTION

3.1 - Serial Input Interface

STA015 receives the input data (MSB first) through the Serial Input Interface (Fig.7). It is a serial communication interface connected to the SDI (Serial Data Input) and SCKR (Receiver Serial Clock).

The interface can be configured to receive data sampled on both rising and falling edge of the SCKR clock. The BIT\_EN pin, when set to low, forces the bitstream input interface to ignore the incoming data. For proper operation BIT\_EN line should be toggled only when SCKR is stable low (for both SCLK\_POL configuration). The possible configurations are described in Fig. 8.

3.2 - GPSO Output Interface

In order to retrieve ADPCM encoded data a General Purpose Serial Output interface is available (in TQFP44 and LFBGA64 packages only). The maximum frequency for GPSO\_SCKR clock is

the DSP system clock frequency divided by 3 (i.e. 8.192 MHz @ 24.58MHz). The interface is based on a simple and configurable 3-lines protocol, as described by figure 10.

3.3 - PCM Output Interface

The decoded audio data are output in serial PCM format. The interface consists of the following signals:

- SDO            PCM Serial Data Output
- SCKT            PCM Serial Clock Output
- LRCLK        Left/Right Channel Selection Clock

The output samples precision is selectable from 16 to 24 bits/word, by setting the output precision with PCMCONF (16, 18, 20 and 24 bits mode) register. Data can be output either with the most significant bit first (MS) or least significant bit first (LS), selected by writing into a flag of the PCMCONF register.

Figure 9 gives a description of the several STA015 PCM Output Formats. The sample rates set decoded by STA015 is described in Table 1.

Figure 9. PCM Output Formats

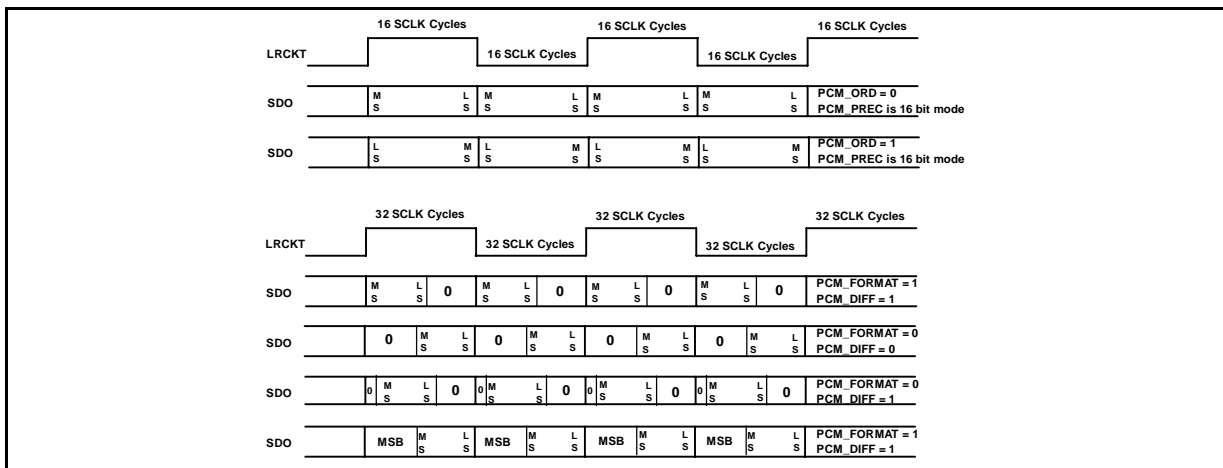
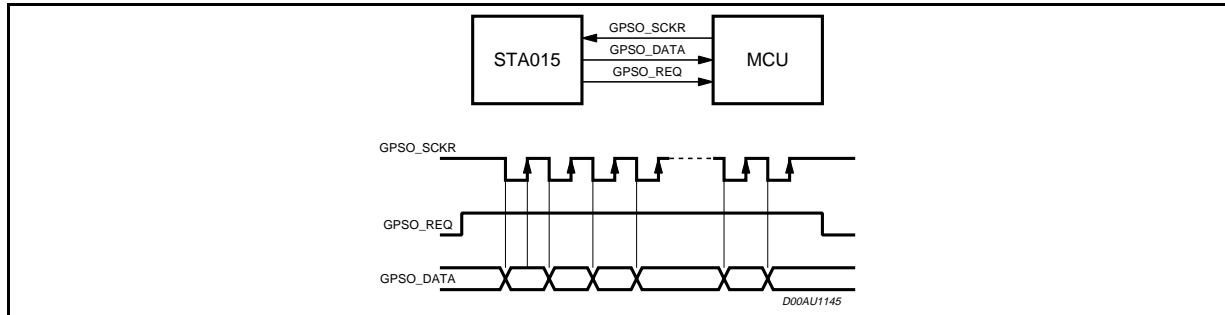

Table 1: MPEG Sampling Rates (KHz)

MPEG 1	MPEG 2	MPEG 2.5
48	24	12
44.1	22.05	11.025
32	16	8

Figure 10.



To enable the GPSO interface bit GEN of GPSO\_ENABLE register must be set. Using the GPSO\_CONF register the protocol can be configured in order to provide outgoing data on rising/falling edge of GPSO\_SCKR input clock; the GPSO\_REQ request signal polarity (usually connected to an MCU interrupt line) can be configured as well.

ADPCM encoding mode to provide an interrupt; other pins are reserved for future use. The related configuration register is GPIO\_CONF. See the following summary for related pin usage:

Name	Description	Dir
I/ODATA [0]	GPIO data line	I/O
.....		...
I/ODATA [7]		I/O
GPIO_STROBE	GPIO strobe line	I/O

**3.4 ADC Interface**

Beside the serial input interface based on SDI and SCKR lines a 3 wire flexible and user configurable input interface is also available, suitable to interface with most A/D converters. To configure this interface 4 specific I<sup>2</sup>C registers are available (ADC\_ENABLE, ADC\_CONF, ADC\_WLEN and ADC\_WPOS). Refer to registers description for more details.

**4 ADPCM ENCODING: Overview**

According to the previously described interfaces there are 4 ways to manage ADPCM data stream while encoding. Input interface can be either the serial receiver block (SDI + SCKR + DATA\_REQ lines) or the ADC specific interface.

**3.5 General Purpose I/O Interface**

A new general purpose I/O interface has been added to this device (TQFP44 and LFBGA64 only). Actually only the strobe line is used in

Output interfaces can be either the I<sup>2</sup>C bus (with or without interrupt line) or the GPSO high-speed serial interface (GPSO\_REQ + GPSO\_DATA + GPSO\_SCKR lines). This result in the following 4 methods to handle encoding flow:

INPUT (data to encode)	Output (encoded data)	Available on package
ADC I/F (SDI_ADC + LRCK_ADC + SCK_ADC)	GPSO I/F (GPSO_REQ + GPSO_DATA + GPSO_SCKR)	TQFP44 LFBGA64
ADC I/F (SDI_ADC + LRCK_ADC + SCK_ADC)	I <sup>2</sup> C + Interrupt (SCL + SDA + DATA_REQ)	SO28/TQFP44 LFBGA64
SERIAL I/F (SCKR + SDI + DATA_REQ)	GPSO I/F (GPSO_REQ + GPSO_DATA + GPSO_SCKR)	TQFP44 LFBGA64
SERIAL I/F (SCKR + SDI + DATA_REQ) (*)	I <sup>2</sup> C (polling) (SCL + SDA)	SO28/TQFP44 LFBGA64

(\*) STA013 Compatible mode

Figure. 11

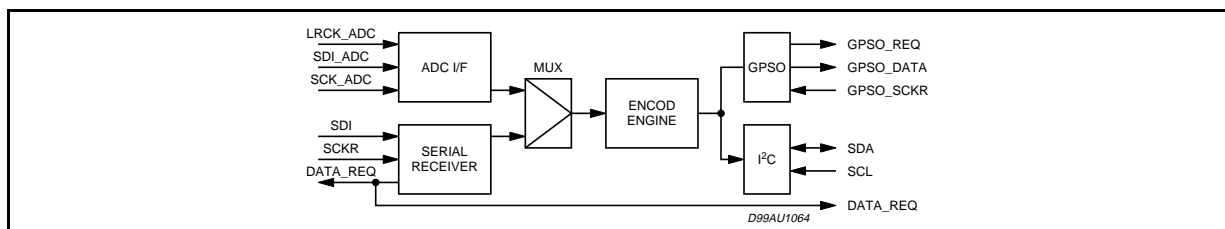

The following 4 figures (fig. 12, 13, 14, 15) show the available connection diagrams as far as ADPCM encoding function. As shown in the figures some configuration is not available in SO28 package.

**Figure 12.** Input from BITSTREAM, Output from I2C

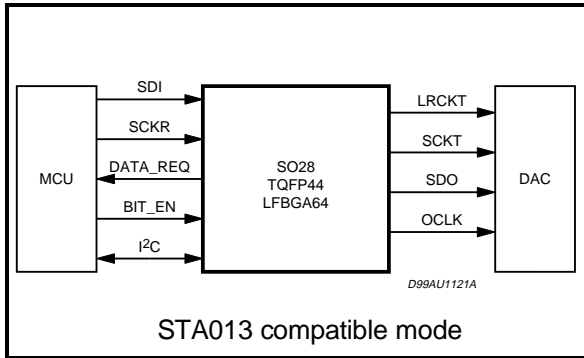

**Figure 14.** Input from BITSTREAM, Output from GPSO

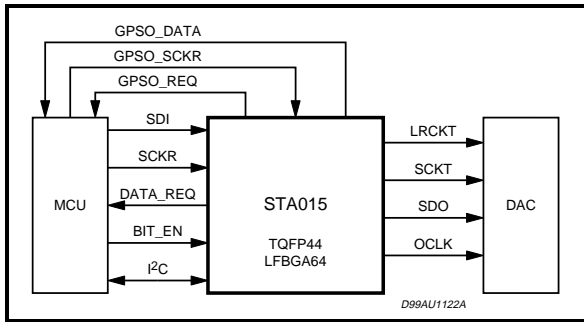

**5 - I<sup>2</sup>C BUS SPECIFICATION**

The STA015 supports the I<sup>2</sup>C protocol. This protocol defines any device that sends data on to the bus as a transmitter and any device that reads the data as a receiver. The device that controls the data transfer is known as the master and the others as the slave. The master always starts the transfer and provides the serial clock for synchronisation. The STA015 is always a slave device in all its communications.

**Figure 13.** Input from ADC, Output from I2C + IRQ

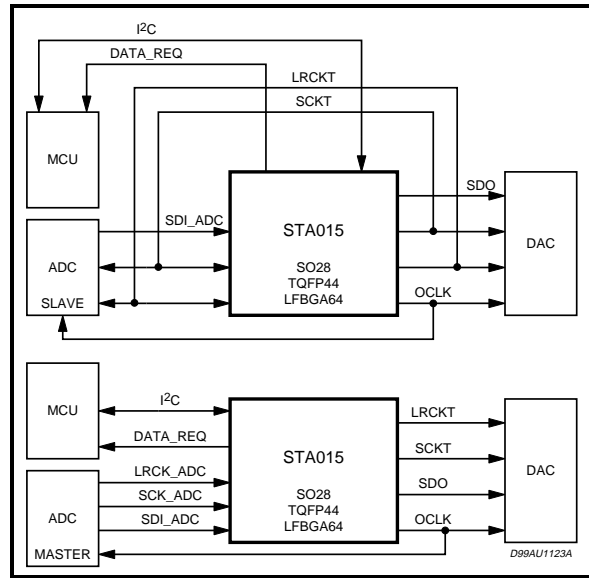

**Figure 15.** Input from ADC, Output from GPSO

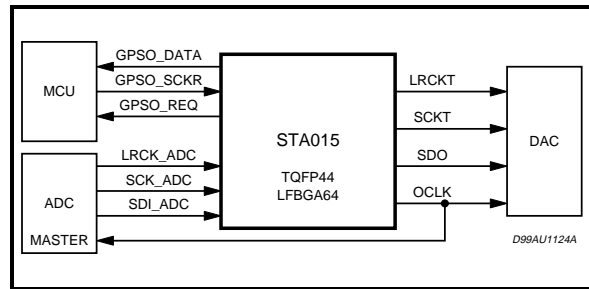

**5. 1 - COMMUNICATION PROTOCOL**

**5.1.0 - Data transition or change**

Data changes on the SDA line must only occur when the SCL clock is low. SDA transition while the clock is high are used to identify START or STOP condition.

**5.1.1 - Start condition**

START is identified by a high to low transition of the data bus SDA signal while the clock signal SCL is stable in the high state. A START condition must precede any command for data transfer.

**5.1.2 - Stop condition**

STOP is identified by low to high transition of the data bus SDA signal while the clock signal SCL is stable in the high state. A STOP condition terminates communications between STA015 and the bus master.

**5.1.3 - Acknowledge bit**

An acknowledge bit is used to indicate a successful data transfer. The bus transmitter, either master or slave, releases the SDA bus after sending 8 bit of data.

During the 9th clock pulse the receiver pulls the SDA bus low to acknowledge the receipt of 8 bits of data.

**5.1.4 - Data input**

During the data input the STA015 samples the SDA signal on the rising edge of the clock SCL.

For correct device operation the SDA signal has to be stable during the rising edge of the clock and the data can change only when the SCL line is low.

**5.2 - DEVICE ADDRESSING**

To start communication between the master and the STA015, the master must initiate with a start condition. Following this, the master sends onto the SDA line 8 bits (MSB first) corresponding to the device select address and read or write mode.

The 7 most significant bits are the device address identifier, corresponding to the I<sup>2</sup>C bus definition. For the STA015 these are fixed as 1000011.

The 8th bit (LSB) is the read or write operation RW, this bit is set to 1 in read mode and 0 for write mode. After a START condition the STA015 identifies on the bus the device address and, if a match is found, it acknowledges the identification on SDA bus during the 9th bit time. The following byte after the device identification byte is the internal space address.

**5.3 - WRITE OPERATION** (see fig. 16)

Following a START condition the master sends a device select code with the RW bit set to 0.

The STA015 acknowledges this and waits for the byte of internal address.

After receiving the internal bytes address the STA015 again responds with an acknowledge.

**5.3.1 - Byte write**

In the byte write mode the master sends one data byte, this is acknowledged by STA015. The master then terminates the transfer by generating a STOP condition.

**5.3.2 - Multibyte write**

The multibyte write mode can start from any internal address. The transfer is terminated by the master generating a STOP condition.

**Figure 16.** Write Mode Sequence

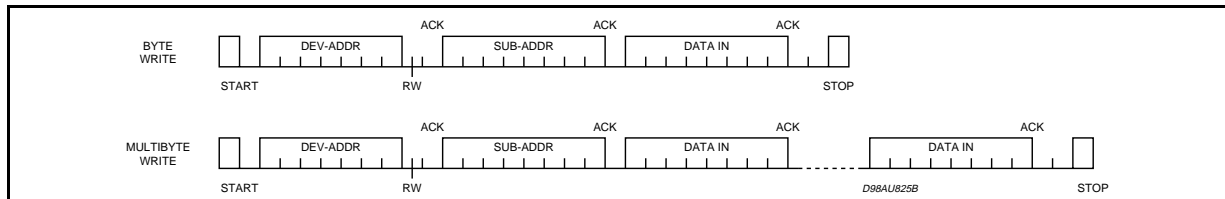

**Figure 17.** Read Mode Sequence

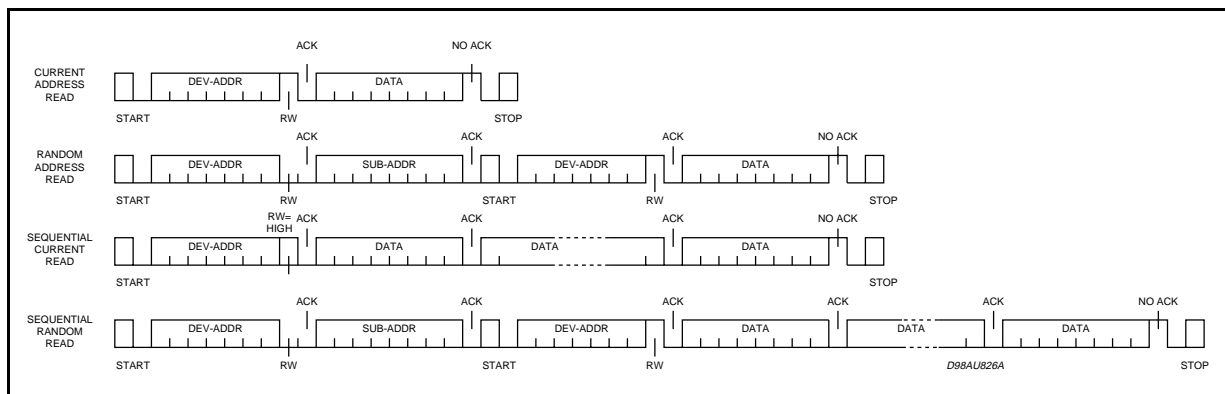

**5.4 - READ OPERATION** (see Fig. 17)

**5.4.1 - Current byte address read**

The STA015 has an internal byte address counter. Each time a byte is written or read, this counter is incremented.

For the current byte address read mode, following a START condition the master sends the device address with the RW bit set to 1.

The STA015 acknowledges this and outputs the byte addressed by the internal byte address counter. The master does not acknowledge the received byte, but terminates the transfer with a STOP condition.

**5.4.2 - Sequential address read**

This mode can be initiated with either a current address read or a random address read. However in this case the master does acknowledge the data byte output and the STA015 continues to output the next byte in sequence.

To terminate the streams of bytes the master does not acknowledge the last received byte, but

terminates the transfer with a STOP condition.

The output data stream is from consecutive byte addresses, with the internal byte address counter automatically incremented after one byte output.

**6 - I<sup>2</sup>C REGISTERS**

The following table gives a description of the MPEG Source Decoder (STA015) register list.

The first column (HEX\_COD) is the hexadecimal code for the sub-address.

The second column (DEC\_COD) is the decimal code.

The third column (DESCRIPTION) is the description of the information contained in the register.

The fourth column (RESET) indicate the reset value if any. When no reset value is specified, the default is "undefined".

The fifth column (R/W) is the flag to distinguish register "read only" and "read and write", and the useful size of the register itself.

Each register is 8 bit wide. The master shall operate reading or writing on 8 bits only.

**I<sup>2</sup>C REGISTERS**

HEX_COD	DEC_COD	DESCRIPTION	RESET	R/W
\$00	0	VERSION		R (8)
\$01	1	IDENT	0xAC	R (8)
\$05	5	PLLCTL [7:0]	0xA1	R/W (8)
\$06	6	PLLCTL [20:16] (MF[4:0]=M)	0x0C	R/W (8)
\$07	7	PLLCTL [15:12] (IDF[3:0]=N)	0x00	R/W (8)
\$0C	12	REQ_POL	0x01	R/W (8)
\$0D	13	SCLK_POL	0x04	R/W (8)
\$0F	15	ERROR_CODE	0x00	R (8)
\$10	16	SOFT_RESET	0x00	W (8)
\$13	19	PLAY	0x01	R/W(8)
\$14	20	MUTE	0x00	R/W(8)
\$16	22	CMD_INTERRUPT	0x00	R/W(8)
\$18	24	DATA_REQ_ENABLE	0x00	R/W(8)
\$40 - \$51	64 - 81	ADPCM_DATA_1 to ADPCM_DATA_18	0x00	R/W (8)
\$40	64	SYNCSTATUS	0x00	R (8)
\$41	65	ANCCOUNT_L	0x00	R (8)
\$42	66	ANCCOUNT_H	0x00	R (8)
\$43	67	HEAD_H[23:16]	0x00	R(8)
\$44	68	HEAD_M[15:8]	0x00	R(8)
\$45	69	HEAD_L[7:0]	0x00	R(8)
\$46	70	DLA	0x00	R/W (8)
\$47	71	DLB	0xFF	R/W (8)
\$48	72	DRA	0x00	R/W (8)

I<sup>2</sup>C REGISTERS (continued)

HEX_COD	DEC_COD	DESCRIPTION	RESET	R/W
\$49	73	DRB	0xFF	R/W (8)
\$4D	77	CHIP_MODE	0x00	R/W (2)
\$4E	78	CRCR	0x00	R/W (1)
\$50	80	MFSDF_441	0x00	R/W (8)
\$51	81	PLLFRAC_441_L	0x00	R/W (8)
\$52	82	ADPCM_DATA_READY	0x00	R/W (1)
\$52	82	PLLFRAC_441_H	0x00	R/W (8)
\$53	83	ADPCM_SAMPLE_FREQ	0x00	R/W (4)
\$54	84	PCM DIVIDER	0x03	R/W (8)
\$55	85	PCMCONF	0x21	R/W (8)
\$56	86	PCMCROSS	0x00	R/W (8)
\$61	97	MFSDF (X)	0x07	R/W (8)
\$63	99	DAC_CLK_MODE	0x00	R/W (8)
\$64	100	PLLFRAC_L	0x46	R/W (8)
\$65	101	PLLFRAC_H	0x5B	R/W (8)
\$67	103	FRAME_CNT_L	0x00	R (8)
\$68	104	FRAME_CNT_M	0x00	R (8)
\$69	105	FRAME_CNT_H	0x00	R (8)
\$6A	106	AVERAGE_BITRATE	0x00	R (8)
\$71	113	SOFTVERSION		R (8)
\$72	114	RUN	0x00	R/W (8)
\$77	119	TREBLE_FREQUENCY_LOW	0x00	R/W (8)
\$78	120	TREBLE_FREQUENCY_HIGH	0x00	R/W (8)
\$79	121	BASS_FREQUENCY_LOW	0x00	R/W (8)
\$7A	122	BASS_FREQUENCY_HIGH	0x00	R/W (8)
\$7B	123	TREBLE_ENHANCE	0x00	R/W (8)
\$7C	124	BASS_ENHANCE	0x00	R/W (8)
\$7D	125	TONE_ATTEN	0x00	R/W (8)
\$7E - B5	126 - 181	ANC_DATA_1 to ANC_DATA_56	0x00	R (8)
\$B6	182	ISR	0x00	R/W (1)
\$B8	184	ADPCM_CONFIG	0x00	R/W (2)
\$B9	185	GPSO_ENABLE	0x00	R/W (1)
\$BA	186	GPSO_CONF	0x00	R/W (2)
\$BB	187	ADC_ENABLE	0x00	R/W (1)
\$BC	188	ADC_CONF	0x00	R/W (5)
\$BD	189	ADPCM_FRAME_SIZE	0x00	R/W (8)
\$BE	190	ADPCM_INT_CFG	0x00	R/W (8)
\$BF	191	GPIO_CONF	0x00	R/W (2)
\$C0	192	ADC_WLEN	0x0F	R/W (5)
\$C1	193	ADC_WPOS	0x00	R/W (5)
\$C2	194	ADPCM_SKIP_FRAME	0x00	R/W (8)

Note:

- 1) The HEX\_COD is the hexadecimal address that the microcontroller has to generate to access the information.
- 2) RESERVED: register used for production test only, or for future use.

**6.1 - STA015 REGISTERS DESCRIPTION**

The STA015 device includes 256 I<sup>2</sup>C registers. In this document, only the user-oriented registers are described. The undocumented registers are reserved. These registers must never be accessed (in Read or in Write mode). The Read-Only registers must never be written.

The following table describes the meaning of the abbreviations used in the I<sup>2</sup>C registers description:

Symbol	Comment
NA	Not Applicable
UND	Undefined
NC	No Charge
RO	Read Only
WO	Write Only
R/W	Read and Write
R/WS	Read, Write in specific mode

**VERSION**

**Address: 0x00 (00)**

Type: RO

MSB							LSB
b7	b6	b5	b4	b3	b2	b1	b0
V8	V7	V6	V5	V4	V3	V2	V1

The VERSION register is read-only and it is used to identify the IC on the application board.

**IDENT**

**Address: 0x01 (01)**

Type: RO

Software Reset: 0xAC

Hardware Reset: 0xAC

MSB							LSB
b7	b6	b5	b4	b3	b2	b1	b0
1	0	1	0	1	1	0	0

IDENT is a read-only register and is used to identify the IC on an application board. IDENT always has the value "0xAC"

**PLLCTL**

**Address: 0x05 (05)**

Type: R/W

Software Reset: 0xA1

Hardware Reset: 0xA1

MSB						LSB	
b7	b6	b5	b4	b3	b2	b1	b0
XTO_BUF	XTOD_IS	OCLK_EN	SYS2O_CLK	PPLD_IS	XTI2DS_PCLK	XTI2O_CLK	UPD_FRAC

UPD\_FRAC: when is set to 1, update FRAC in the switching circuit. It is set to 1 after autoboot.

XTI2OCLK: when is set to 1, use the XTI as input of the divider X instead of VCO output. It is set to 0 on HW reset.

XTI2DSPCLK: when is to 1, set use the XTI as input of the divider S instead of VCO output. It is set to 0 on HW reset.

PLLDIS: when set to 1, the VCO output is disabled. It is set to 0 on HW reset.

SYS2OCLK: when is set to 1, the OCLK frequency is equal to the system frequency. It is useful for testing. It is set to 0 on HW reset.

OCLKEN: when is set to 1, the OCLK pad is enable as output pad. It is set to 1 on HW reset.

XTODIS: when is set to 1, the XTO pad is disable. It is set to 0 on HW reset.

XTO\_BUF: when this bit is set, the pin nr. 28 (OUT\_CLOCK/DATA\_REQ) is enabled. It is set to 0 after autoboot.

**PLLCTL (M)**

**Address: 0x06 (06)**

Type: R/W

Software Reset: 0x0C

Hardware Reset: 0x0C

**PLLCTL (N)**

**Address: 0x07 (07)**

Type: R/W

Software Reset: 0x00

Hardware Reset: 0x00

The M and N registers are used to configure the STA015 PLL by DSP embedded software.

M and N registers are R/W type but they are completely controlled, on STA015, by DSP software.



**REQ\_POL**

**Address: 0x0C (12)**

Type: R/W

Software Reset: 0x01

Hardware Reset: 0x00

The REQ\_POL registers is used to program the polarity of the DATA\_REQ line.

MSB							LSB
b7	b6	b5	b4	b3	b2	b1	b0
0	0	0	0	0	0	0	1

Default polarity (the source sends data when the DATA\_REQ line is high)

MSB							LSB
b7	b6	b5	b4	b3	b2	b1	b0
0	0	0	0	0	1	0	1

Inverted polarity (the source sends data when the DATA\_REQ line is low)

**SCLK\_POL**

**Address: 0x0D (13)**

Type: R/W

Software Reset: 0x04

Hardware Reset: 0x04

MSB							LSB
b7	b6	b5	b4	b3	b2	b1	b0
X	X	X	X	X	0	0	0
					1	0	0

(1) (2)

X = don't care

SCLK\_POL is used to select the working polarity of the Input Serial Clock (SCKR).

- (1) If SCLK\_POL is set to 0x00, the data (SDI) are sent with the falling edge of SCKR and sampled on the rising edge.
- (2) If SCLK\_POL is set to 0x04, the data (SDI) are sent with the rising edge of SCKR and sampled on the falling edge.

**ERROR\_CODE**

**Address: 0x0F (15)**

Type: RO

Software Reset: 0x00

Hardware Reset: 0x00

MSB							LSB
b7	b6	b5	b4	b3	b2	b1	b0
X	X	EC5	EC4	EC3	EC2	EC1	EC0

X = don't care

ERROR\_CODE register contains the last error occurred if any. The codes can be as follows:

Code	Description
0x00	No error since the last SW or HW Reset
0x01	CRC Failure
0x02	DATA not available
0x04	Ancillary data not read
0x10	Audio synch word not found
0x2X	MPEG Header error
0x3X	MPEG Decoding errors

**SOFT\_RESET**

**Address: 0x10 (16)**

Type: WO

Software Reset: 0x00

Hardware Reset: 0x00

MSB							LSB
b7	b6	b5	b4	b3	b2	b1	b0
X	X	X	X	X	X	X	0
							1

X = don't care; 0 = normal operation; 1 = reset

When this register is written, a soft reset occurs. The STA015 core command register and the interrupt register are cleared. The decoder goes in to idle mode.

**PLAY**

**Address: 0x13 (19)**

Type: R/W

Software Reset: 0x01

Hardware Reset: 0x01

MSB							LSB
b7	b6	b5	b4	b3	b2	b1	b0
X	X	X	X	X	X	X	0
							1

X = don't care; 0 = normal operation; 1 = play

The PLAY command is handled according to the state of the decoder, as described in section 2.5. PLAY only becomes active when the decoder is in DECODE mode.



**MUTE**

**Address: 0x14 (20)**

Type: R/W

Software Reset: 0x00

Hardware Reset: 0x00

MSB							LSB
b7	b6	b5	b4	b3	b2	b1	b0
X	X	X	X	X	X	X	0
							1

X = don't care; 0 = normal operation; 1 = mute  
 The MUTE command is handled according to the state of the decoder, as described in section 2.5.  
 MUTE sets the clock running.

**CMD\_INTERRUPT**

**Address: 0x16 (22)**

Type: R/W

Software Reset: 0x00

Hardware Reset: 0x00

MSB							LSB
b7	b6	b5	b4	b3	b2	b1	b0
X	X	X	X	X	X	X	0
							1

X = don't care;  
 0 = normal operation;  
 1 = write into I<sup>2</sup>C/Ancillary Data  
 The INTERRUPT is used to give STA015 the command to write into the I2C/Ancillary Data Buffer (Registers: 0x7E ... 0xB5). Every time the Master has to extract the new buffer content it writes into this register, setting it to a non-zero value.

**DATA\_REQ\_ENABLE**

**Address: 0x18 (24)**

Type: R/W

Software Reset: 0x00

Hardware Reset: 0x00

MSB						LSB		Description
b7	b6	b5	b4	b3	b2	b1	b0	
X	X	X	X	X	0	X	X	buffered output clock
X	X	X	X	X	1	X	X	request signal

The DATA\_REQ\_ENABLE register is used to configure Pin n. 28 working as buffered output clock or data request signal, used for multimedia

mode.  
 The buffered Output Clock has the same frequency than the input clock (XTI)

**SYNCSTATUS**

**Address: 0x40 (64)**

Type: RO

Software Reset: 0x00

Hardware Reset: 0x00

MSB						LSB		Description
b7	b6	b5	b4	b3	b2	b1	b0	
X	X	X	X	X	X	SS1	SS0	
						0	0	Research of sync word
						0	1	Wait for Confirmation
						1	0	Synchronised

**ADPCM\_DATA BUFFER**

**Address: 0x40 - 0x51 (64 - 81)**

Type: R/W

Software Reset: 0x00

Hardware Reset: 0x00

MSB							LSB
b7	b6	b5	b4	b3	b2	b1	b0
ENCODED DATA N to N+18							

**ANCCOUNT\_L**

**Address: 0x41 (65)**

Type: RO

Software Reset: 0x00

Hardware Reset: 0x00

MSB							LSB
b7	b6	b5	b4	b3	b2	b1	b0
AC7	AC6	AC5	AC4	AC3	AC2	AC1	AC0

**ANCCOUNT\_H**

**Address: 0x42 (66)**

Type: RO

Software Reset: 0x00

Hardware Reset: 0x00

ANCCOUNT\_H

MSB							LSB
b7	b6	b5	b4	b3	b2	b1	b0
AC15	AC14	AC13	AC12	AC11	AC10	AC9	AC8

ANCCOUNT registers are logically concatenated and indicate the number of Ancillary Data bits available at every correctly decoded MPEG frame.

**HEAD\_H[23:16]**

MSB							LSB
b7	b6	b5	b4	b3	b2	b1	b0
X	X	X	H20	H19	H18	H17	H16

x = don't care

**HEAD\_M[15:8]**

MSB							LSB
b7	b6	b5	b4	b3	b2	b1	b0
H15	H14	H13	H12	H11	H10	H9	H8

**HEAD\_L[7:0]**

MSB						LSB	
b7	b6	b5	b4	b3	b2	b1	b0
H7	H6	H5	H4	H3	H2	H1	H0

**Address: 0x43, 0x44, 0x45 (67, 68, 69)**

Type: RO

Software Reset: 0x00

Hardware Reset: 0x00

Head[1:0] emphasis

Head[2] original/copy

Head[3] copyrightHead

[5:4] mode extension

Head[7:6] mode

Head[8] private bit

Head[9] padding bit

Head[11:10] sampling frequency index

Head[15:12] bitrate index

Head[16] protection bit

Head[18:17] layer

Head[19] ID

Head[20] ID\_ex

The HEAD registers can be viewed as logically concatenated to store the MPEG Layer III Header content. The set of three registers is updated every time the synchronisation to the new MPEG frame is achieved

The meaning of the flags are shown in the following tables:

MPEG IDs

IDex	ID	
0	0	MPEG 2.5
0	1	reserved
1	0	MPEG 2
1	1	MPEG 1

Layer

in Layer III these two flags must be set always to "01".

Protection\_bit

It equals "1" if no redundancy has been added and "0" if redundancy has been added.

**Bitrate\_index**

indicates the bitrate (Kbit/sec) depending on the MPEG ID.

bitrate index	ID = 1	ID = 0
'0000'	free	free
'0001'	32	8
'0010'	40	16
'0011'	48	24
'0100'	56	32
'0101'	64	40
'0110'	80	48
'0111'	96	56
'1000'	112	64
'1001'	128	80
'1010'	160	96
'1011'	192	112
'1100'	224	128
'1101'	256	144
'1110'	320	160
'1111'	forbidden	forbidden

**Sampling Frequency**

indicates the sampling frequency of the encoded audio signal (KHz) depending on the MPEG ID

Sampling Frequency	MPEG1	MPEG2	MPEG2.5
'00'	44.1	22.05	11.03
'01'	48	24	12
'10'	32	16	8
'11'	reserved	reserved	reserved

**Padding bit**

if this bit equals '1', the frame contains an additional slot to adjust the mean bitrate to the sampling frequency, otherwise this bit is set to '0'.

**DLA**

**Address: 0x46 (70)**

Type: R/W

Software Reset: 0x00

Hardware Reset: 0x00

MSB				LSB				Description
b7	b6	b5	b4	b3	b2	b1	b0	
DLA7	DLA6	DLA5	DLA4	DLA3	DLA2	DLA1	DLA0	OUTPUT ATTENUATION
0	0	0	0	0	0	0	0	NO ATTENUATION
0	0	0	0	0	0	0	1	-1dB
0	0	0	0	0	0	1	0	-2dB
:	:	:	:	:	:	:	:	:
0	1	1	0	0	0	0	0	-96dB

**Private bit**

Bit for private use. This bit will not be used in the future by ISO/IEC.

**Mode**

Indicates the mode according to the following table. The joint stereo mode is intensity\_stereo and/or ms\_stereo.

mode	mode specified
'00'	stereo
'01'	joint stereo (intensity_stereo and/or ms_stereo)
'10'	dual_channel
'11'	single_channel (mono)

**Mode extension**

These bits are used in joint stereo mode. They indicate which type of joint stereo coding method is applied. The frequency ranges, over which the intensity\_stereo and ms\_stereo modes are applied, are implicit in the algorithm.

**Copyright**

If this bit is equal to '0', there is no copyright on the bitstream, '1' means copyright protected.

**Original/Copy**

This bit equals '0' if the bitstream is a copy, '1' if it is original.

**Emphasis**

Indicates the type of de-emphasis that shall be used.

emphasis	emphasis specified
'00'	none
'01'	50/15 microseconds
'10'	reserved
'11'	CCITT J,17

DLA register is used to attenuate the level of audio output at the Left Channel using the butterfly shown in Fig. 18. When the register is set to

255 (0xFF), the maximum attenuation is achieved. A decimal unit correspond to an attenuation step of 1 dB.

**Figure 18.** Volume Control and Output Setup

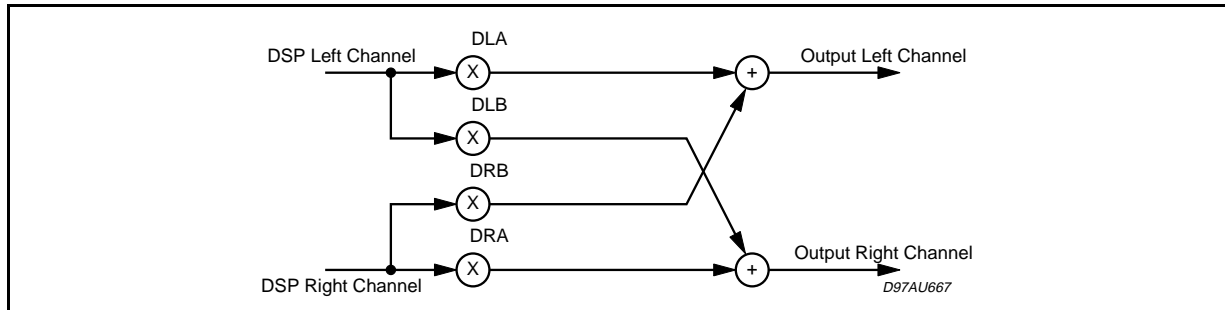

**DLB**

**Address: 0x47 (71)**

Type: R/W

Software Reset: 0xFF

Hardware Reset: 0xFF

MSB				LSB				Description
b7	b6	b5	b4	b3	b2	b1	b0	
DLB7	DLB6	DLB5	DLB4	DLB3	DLB2	DLB1	DLB0	OUTPUT ATTENUATION
0	0	0	0	0	0	0	0	NO ATTENUATION
0	0	0	0	0	0	0	1	-1dB
0	0	0	0	0	0	1	0	-2dB
:	:	:	:	:	:	:	:	:
0	1	1	0	0	0	0	0	-96dB

DLB register is used to re-direct the Left Channel on the Right, or to mix both the Channels.

Default value is 0x00, corresponding at the maximum attenuation in the re-direction channel.

**DRA**

**Address: 0x48 (72)**

Type: R/W

Software Reset: 0X00

Hardware Reset: 0X00

MSB				LSB				Description
b7	b6	b5	b4	b3	b2	b1	b0	
DRA7	DRA6	DRA5	DRA4	DRA3	DRA2	DRA1	DRA0	OUTPUT ATTENUATION
0	0	0	0	0	0	0	0	NO ATTENUATION
0	0	0	0	0	0	0	1	-1dB
0	0	0	0	0	0	1	0	-2dB
:	:	:	:	:	:	:	:	:
0	1	1	0	0	0	0	0	-96dB

DRA register is used to attenuate the level of audio output at the Right Channel using the butterfly shown in Fig. 11. When the register is set to

255 (0xFF), the maximum attenuation is achieved. A decimal unit correspond to an attenuation step of 1 dB.

**DRB**

**Address: 0x49 (73)**

Type: R/W

Software Reset: 0xFF

Hardware Reset: 0xFF

MSB				LSB				
b7	b6	b5	b4	b3	b2	b1	b0	Description
DRB7	DRB6	DRB5	DRB4	DRB3	DRB2	DRB1	DRB0	OUTPUT ATTENUATION
0	0	0	0	0	0	0	0	NO ATTENUATION
0	0	0	0	0	0	0	1	-1dB
0	0	0	0	0	0	1	0	-2dB
:	:	:	:	:	:	:	:	:
0	1	1	0	0	0	0	0	-96dB

DRB register is used to re-direct the Right Channel on the Left, or to mix both the Channels. Default value is 0x00, corresponding at the maximum attenuation in the re-direction channel.

**CHIP\_MODE**

**Address: 0x4D (77)**

Type: R/W

Hardware Reset: 0x00

Using this register it's possible to select which operation will be performed by the DSP.

Possible values are:

0x00 - MP3 decoding

0x01 - Reserved

0x02 - ADPCM Encoder

0x03 - ADPCM Decoder

0x04 - BYPASS mode

The DSP will check for the value of this register right after the RUN command has been issued (refer to RUN register). After that no more checks will be performed: therefore a SOFT\_RESET must be generated in order to change the device mode.

**CRCR**

**Address: 0x4E (78)**

Type: R/W

Software Reset: 0x00

Hardware Reset: 0x00

MSB							LSB
b7	b6	b5	b4	b3	b2	b1	b0
X	X	X	X	X	X	X	CRCEN

The CRC register is used to enable/disable the

CRC check. If CRC\_EN bit is cleared, the CRC value encoded in the bitstream is checked against the hardware one. If a discrepancy occurs, the current frame is skipped and the decoder is muted. The ERROR\_CODE register is affected with the value 0x01.

If CRC\_EN bit is set, the result of the CRC check is ignored, but the ERROR\_CODE register is nevertheless affected with the value 0x01 if a discrepancy has occurred.

**MFSDF\_441**

**Address: 0x50 (80)**

Type: R/W

Software Reset: 0x00

Hardware Reset: 0x00

MSB						LSB	
b7	b6	b5	b4	b3	b2	b1	b0
X	X	X	M4	M3	M2	M1	M0

This register contains the value for the PLL X driver for the 44.1KHz reference frequency.

The VCO output frequency, when decoding 44.1KHz bitstream, is divided by (MFSDF\_441 + 1)

**PLLFRAC\_441\_L**

**Address: 0x51 (81)**

Type: R/W

Software Reset: 0x00

Hardware Reset: 0x00

MSB						LSB	
b7	b6	b5	b4	b3	b2	b1	b0
PF7	PF6	PF5	PF4	PF3	PF2	PF1	PF0



**ADPCM\_DATA\_READY**

**Address: 0x52 (82)**

Type: R/W

Software Reset: 0x00

Hardware Reset: 0x00

MSB							LSB
b7	b6	b5	b4	b3	b2	b1	b0
X	X	X	X	X	X	X	ADR

ADR: Adpcm Data Ready

This bit signal ADPCM encoded data are ready to be retrieved.

**PLLFRAC\_441\_H**

**Address: 0x52 (82)**

Type: R/W

Software Reset: 0x00

Hardware Reset: 0x00

MSB							LSB
b7	b6	b5	b4	b3	b2	b1	b0
PF15	PF14	PF13	PF12	PF11	PF10	PF9	PF8

The registers are considered logically concatenated and contain the fractional values for the PLL, for 44.1KHz reference frequency.

(see also PLLFRAC\_L and PLLFRAC\_H registers)

**ADPCM\_SAMPLE\_FREQ**

**Address: 0x53 (83)**

Type: R/W

Software Reset: 0x00

Hardware Reset: 0x00

MSB						LSB	
b7	b6	b5	b4	b3	b2	b1	b0
X	X	X	ADPCM_SF				

ADPCM\_SF: Adpcm Sample Frequency

0x02	8KHz
0x0A	16KHz
0x0E	32KHz

**PCMDIVIDER**

**Address: 0x54 (84)**

Type: RW

Software Reset: 0x01

Hardware Reset: 0x01

7	6	5	4	3	2	1	0
PD7	PD6	PD5	PD4	PD3	PD2	PD1	PD0

PCMDIVIDER is used to set the frequency ratio between the OCLK (Oversampling Clock for DACs), and the SCKT (Serial Audio Transmitter Clock).

The relation is the following:

$$SCKT\_freq = \frac{OCLK\_freq}{2(1 + PCM\_DIV)}$$

The Oversampling Factor (O\_FAC) is related to OCLK and SCKT by the following expression:

- 1)  $OCLK\_freq = O\_FAC * LRCKT\_Freq$   
(DAC relation)
- 2)  $OCLK\_Freq = 2 * (1+PCM\_DIV) * 32*$   
LRCKT\_Freq (when 16 bit PCM mode is used)
- 3)  $OCLK\_Freq = 2 * (1+PCM\_DIV) * 64*$   
LRCKT\_Freq (when 32 bit PCM mode is used)
- 4)  $PCM\_DIV = (O\_FAC/64) - 1$  in 16 bit mode
- 5)  $PCM\_DIV = (O\_FAC/128) - 1$  in 32 bit mode

Example for setting:

MSB				LSB				Description	
b7	b6	b5	b4	b3	b2	b1	b0		
PD7	PD6	PD5	PD4	PD3	PD2	PD1	PD0		
0	0	0	0	0	1	1	1	16 bit mode	512 x Fs
0	0	0	0	0	1	0	1	16 bit mode	384 x Fs
0	0	0	0	0	0	1	1	16 bit mode	256 x Fs
0	0	0	0	0	0	1	1	32 bit mode	512 x Fs
0	0	0	0	0	0	1	0	32 bit mode	384 x Fs
0	0	0	0	0	0	0	1	32 bit mode	256 x Fs

for 16 bit PCM Mode

- O\_FAC = 512 ; PCM\_DIV = 7
- O\_FAC = 256 ; PCM\_DIV = 3
- O\_FAC = 384 ; PCM\_DIV = 5

for 32 bit PCM Mode

- O\_FAC = 512 ; PCM\_DIV = 3
- O\_FAC = 256 ; PCM\_DIV = 1
- O\_FAC = 384 ; PCM\_DIV = 2



**PCMCONF**

Address: 0x55 (85)

Type: R/W

Software Reset: 0x21

Hardware Reset: 0x21

MSB				LSB				Description
b7	b6	b5	b4	b3	b2	b1	b0	
X	ORD	DIF	INV	FOR	SCL	PREC (1)	PREC (1)	
X	1							PCM order the LS bit is transmitted First
X	0							PCM order the MS bit is transmitted First
X		0						The word is right aligned
X		1						The word is left aligned
X			0					LRCKT Polarity compliant to I2S format
X			1					LRCKT Polarity inverted
X				0				I2S format
X				1				Different formats
X					1			Data are sent on the rising edge of SCKT
X					0			Data are sent on the falling edge of SCKT
X						0	0	16 bit mode (16 slots transmitted)
X						0	1	18 bit mode (32 slots transmitted)
X						1	0	20 bit mode (32 slots transmitted)
X						1	1	24 bit mode (32 slots transmitted)

PCMCONF is used to set the PCM Output Interface configuration:

ORD: PCM order. If this bit is set to '1', the LS Bit is transmitted first, otherwise MS Bit is transmitted first.

DIF: PCM\_DIFF. It is used to select the position of the valid data into the transmitted word. This setting is significant only in 18/20/24 bit/word mode. If it is set to '0' the word is right-padded, otherwise it is left-padded.

INV (fig.13): It is used to select the LRCKT clock polarity. If it is set to '0' the polarity is compliant to I2S format (low -> left, high -> right), otherwise the LRCKT is inverted. The default value is '0'. (if I2S have to be selected, must be set to '0' in the STA015 configuration phase).

**Figure 19.** LRCKT Polarity Selection

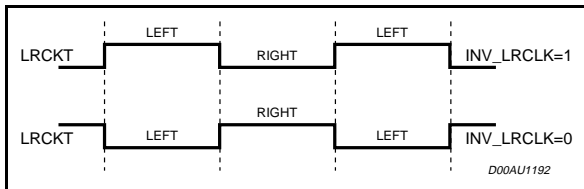

FOR: FORMAT is used to select the PCM Output Interface format.

After hw and sw reset the value is set to 0 corresponding to I<sup>2</sup>S format.

SCL (fig.14): used to select the Transmitter Serial Clock polarity. If set to '1' the data are sent on the

rising edge of SCKT and sampled on the falling. If set to '0', the data are sent on the falling edge and sampled on the rising. This last option is the most commonly used by the commercial DACs. The default configuration for this flag is '0'.

**Figure 20.** SCKT Polarity Selection

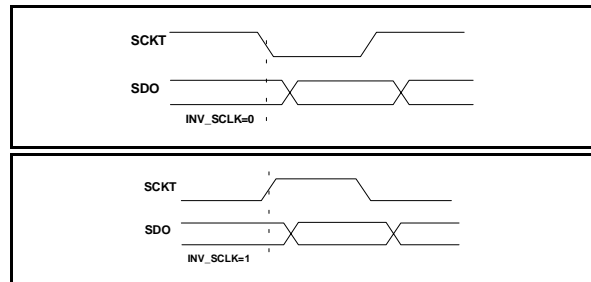

**PREC [1:0]: PCM PRECISION**

It is used to select the PCM samples precision, as follows:

'00': 16 bit mode (16 slots transmitted)

'01': 18 bit mode (32 slots transmitted)

'10': 20 bit mode (32 slots transmitted)

'11': 24 bit mode (32 slots transmitted)

The PCM samples precision in STA015 can be 16 or 18-20-24 bits.

When STA015 operates in 16 (18-20-24) bits mode, the number of bits transmitted during a LRCKT period is 32 (64).

**PCMCROSS**

**Address: 0x56 (86)**

Type: R/W

Software Reset: 0x00

Hardware Reset: 0x00

MSB							LSB		Description
b7	b6	b5	b4	b3	b2	b1	b0		
X	X	X	X	X	X	0	0	Left channel is mapped on the left output. Right channel is mapped on the Right output	
X	X	X	X	X	X	0	1	Left channel is duplicated on both Output channels.	
X	X	X	X	X	X	1	0	Right channel is duplicated on both Output channels	
X	X	X	X	X	X	1	1	Right and Left channels are toggled	

The default configuration for this register is '0x00'.

**MFSDF (X)**

**Address: 0x61 (97)**

Type: R/W

Software Reset: 0x07

Hardware Reset: 0x07

MSB							LSB	
b7	b6	b5	b4	b3	b2	b1	b0	
X	X	X	M4	M3	M2	M1	M0	

The register contains the values for PLL X divider (see Fig. 7).

The value is changed by the internal STA015 Core, to set the clocks frequencies, according to the incoming bitstream. This value can be even set by the user to select the PCM interface configuration.

The VCO output frequency is divided by (X+1).

This register is a reference for 32KHz and 48 KHz input bitstream.

**DAC\_CLK\_MODE (99)**

**Address: 0x63**

Type: RW

Software Reset: 0x00

Hardware Reset: 0x00

MSB							LSB	
b7	b6	b5	b4	b3	b2	b1	b0	
X	X	X	X	X	X	X	MODE	

This register is used to select the operating mode for OCLK clock signal. If it is set to '1', the OCLK frequency is fixed, and it is maintained to the value fixed by the user even if the sampling frequency of the incoming bitstream changes. If the MODE flag is set to '0', the OCLK frequency changes, and can be set to (512, 384, 256) \* Fs. The default configuration for this mode is 256 \*

Fs. When this mode is selected, the default OCLK frequency is 12.288 MHz.

**PLLFRAC\_L ([7:0])**

MSB							LSB	
b7	b6	b5	b4	b3	b2	b1	b0	
PF7	PF6	PF5	PF4	PF3	PF2	PF1	PF0	

**PLLFRAC\_H ([15:8])**

MSB							LSB	
b7	b6	b5	b4	b3	b2	b1	b0	
PF15	PF14	PF13	PF12	PF11	PF10	PF9	PF8	

**Address: 0x64 - 0x65 (100 - 101)**

Type: R/W

Software Reset: 0x46 | 0x5B

Hardware Reset: 0xNA | 0x5B

The registers are considered logically concatenated and contain the fractional values for the PLL, used to select the internal configuration.

After Reset, the values are NA, and the operational setting are done when the MPEG synchronisation is achieved.

The following formula describes the relationships among all the STA015 fractional PLL parameters:

$$OCLK\_Freq = \left[ \frac{1}{X+1} \right] \cdot \left[ \frac{MCLK\_freq}{N+1} \right] \cdot \left[ M+1 + \frac{FRAC}{65536} \right]$$

where:

FRAC=256 x FRAC\_H + FRAC\_L (decimal)

These registers are a reference for 48 / 24 / 12 / 32 / 16 / 8KHz audio.



**FRAME\_CNT\_L**

MSB							LSB
b7	b6	b5	b4	b3	b2	b1	b0
FC7	FC6	FC5	FC4	FC3	FC2	FC1	FC0

**FRAME\_CNT\_M**

MSB							LSB
b7	b6	b5	b4	b3	b2	b1	b0
FC15	FC14	FC13	FC12	FC11	FC10	FC9	FC8

**FRAME\_CNT\_H**

MSB							LSB
b7	b6	b5	b4	b3	b2	b1	b0
FC23	FC22	FC21	FC20	FC19	FC18	FC17	FC016

**Address: 0x67, 0x68, 0x69 (103 - 104 - 105)**

Type: RO  
 Software Reset: 0x00  
 Hardware Reset: 0x00

The three registers are considered logically concatenated and compose the Global Frame Counter as described in the table.

It is updated at every decoded MPEG Frame. The registers are reset on both hardware and software reset.

**AVERAGE\_BITRATE**

**Address: 0x6A (106)**

Type: RO  
 Software Reset: 0x00  
 Hardware Reset: 0x00

MSB							LSB
b7	b6	b5	b4	b3	b2	b1	b0
AB7	AB6	AB5	AB4	AB3	AB2	AB1	AB0

AVERAGE\_BITRATE is a read-only register and it contains the average bitrate of the incoming bit-stream divided by two. The value is rounded with an accuracy of 1 Kbit/sec.

**SOFTVERSION**

**Address: 0x71 (113)**

Type: RO

MSB							LSB
b7	b6	b5	b4	b3	b2	b1	b0
SV7	SV6	SV5	SV4	SV3	SV2	SV1	SV0

After the STA015 boot, this register contains the version code of the embedded software.

**RUN**

**Address: 0x72 (114)**

Type: RW  
 Software Reset: 0x00  
 Hardware Reset: 0x00

MSB							LSB
b7	b6	b5	b4	b3	b2	b1	b0
X	X	X	X	X	X	X	RUN

Setting this register to 1, STA015 leaves the idle state, starting the decoding process. The Microcontroller is allowed to set the RUN flag, once all the control registers have been initialized.

**TREBLE\_FREQUENCY\_LOW**

**Address: 0x77 (119)**

Type: RW  
 Software Reset: 0x00  
 Hardware Reset: 0x00

MSB							LSB
b7	b6	b5	b4	b3	b2	b1	b0
TF7	TF6	TF5	TF4	TF3	TF2	TF1	TF0

**TREBLE\_FREQUENCY\_HIGH**

**Address: 0x78 (120)**

Type: RW  
 Software Reset: 0x00  
 Hardware Reset: 0x00

MSB							LSB
b7	b6	b5	b4	b3	b2	b1	b0
TF15	TF14	TF13	TF12	TF11	TF10	TF9	TF8

The registers TREBLE\_FREQUENCY-HIGH and TREBLE\_FREQUENCY-LOW, logically concatenated as a 16 bit wide register, are used to select the frequency, in Hz, where the selected frequency is +12dB respect to the stop band.

By setting these registers, the following rule must be kept:

$$\text{Treble\_Freq} < F_s/2$$



**BASS\_FREQUENCY\_LOW**

Address: 0x79 (121)

Software Reset: 0x00

Hardware Reset: 0x00

MSB				LSB			
b7	b6	b5	b4	b3	b2	b1	b0
BF7	BF6	BF5	BF4	BF3	BF2	BF1	BF0

**BASS\_FREQUENCY\_HIGH**

Address: 0x7A (122)

Software Reset: 0x00

Hardware Reset: 0x00

MSB				LSB			
b7	b6	b5	b4	b3	b2	b1	b0
BF15	BF14	BF13	BF12	BF11	BF10	BF9	BF8

The registers BASS\_FREQUENCY\_HIGH and BASS\_FREQUENCY\_LOW, logically concatenated as a 16 bit wide register, are used to select the frequency, in Hz, where the selected frequency is -12dB respect to the pass-band. By setting the BASS\_FREQUENCY registers, the following rules must be kept:

Bass\_Freq <= Treble\_Freq

Bass\_Freq > 0

(suggested range: 20 Hz < Bass\_Freq < 750 Hz)

Example:

Bass = 200Hz

Treble = 3kHz

**TFS**

15	14	13	12	11	10	9	8	7	6	5	4	3	2	1	0
0	0	0	0	1	0	1	1	1	0	1	1	1	0	0	0

**BFS**

15	14	13	12	11	10	9	8	7	6	5	4	3	2	1	0
0	0	0	0	0	0	0	0	1	1	0	0	1	0	0	0

**TREBLE\_ENHANCE**

Address: 0x7B (123)

Software Reset: 0x00

Hardware Reset: 0x00

MSB				LSB			
b7	b6	b5	b4	b3	b2	b1	b0
TE7	TE6	TE5	TE4	TE3	TE2	TE1	TE0

Signed number (2 complement)

This register is used to select the enhancement or attenuation STA015 has to perform on Treble Frequency range at the digital signal.

A decrement (increment) of a decimal unit corresponds to a step of attenuation (enhancement) of 1.5dB.

The allowed Attenuation/Enhancement range is [-18dB, +18dB].

MSB				LSB				ENHANCE/ATTENUATION
b7	b6	b5	b4	b3	b2	b1	b0	1.5dB step
0	0	0	0	1	1	0	0	+18
0	0	0	0	1	0	1	1	+16.5
0	0	0	0	1	0	1	0	+15
0	0	0	0	1	0	0	1	+13.5

⋮

0	0	0	0	0	0	0	1	+1
0	0	0	0	0	0	0	0	0
1	1	1	1	1	1	1	1	-1

⋮

1	1	1	1	0	1	1	1	-13.5
1	1	1	1	0	1	1	0	-15
1	1	1	1	0	1	0	0	-16.5
1	1	1	1	0	1	0	0	-18

**BASS\_ENHANCE**  
**Address: 0x7C (124)**  
 Software Reset: 0x00  
 Hardware Reset: 0x00

This register is used to select the enhancement or attenuation STA015 has to perform on Bass Frequency range at the digital signal.

A decrement (increment) of a decimal unit corresponds to a step of attenuation (enhancement) of 1.5dB.

The allowed Attenuation/Enhancement range is [-18dB, +18dB].

MSB				LSB			
b7	b6	b5	b4	b3	b2	b1	b0
BE7	BE6	BE5	BE4	BE3	BE2	BE1	BE0

Signed number (2 complement)

MSB				LSB				ENHANCE/ATTENUATION
b7	b6	b5	b4	b3	b2	b1	b0	1.5dB step
0	0	0	0	1	1	0	0	+18
0	0	0	0	1	0	1	1	+16.5
0	0	0	0	1	0	1	0	+15
0	0	0	0	1	0	0	1	+13.5
⋮								
0	0	0	0	0	0	0	1	+1
0	0	0	0	0	0	0	0	0
1	1	1	1	1	1	1	1	-1
⋮								
1	1	1	1	0	1	1	1	-13.5
1	1	1	1	0	1	1	0	-15
1	1	1	1	0	1	0	0	-16.5
1	1	1	1	0	1	0	0	-18

**TONE\_ATTEN**  
**Address: 0x7D (125)**  
 Type: RW  
 Software Reset: 0x00  
 Hardware Reset: 0x00

MSB				LSB			
b7	b6	b5	b4	b3	b2	b1	b0
TA7	TA6	TA5	TA4	TA3	TA2	TA1	TA0

In the digital output audio, the full signal is achieved with 0 dB of attenuation. For this rea-

son, before applying Bass & Treble Control, the user has to set the TONE\_ATTEN register to the maximum value of enhancement is going to perform.

For example, in case of a 0 dB signal (max. level) only attenuation would be possible. If enhancement is desired, the signal has to be attenuated accordingly before in order to reserve a margin in dB.

An increment of a decimal unit corresponds to a Tone Attenuation step of 1.5dB.

MSB				LSB				ATTENUATION
b7	b6	b5	b4	b3	b2	b1	b0	
0	0	0	0	0	0	0	0	-1.5dB step
0	0	0	0	0	0	0	0	0dB
0	0	0	0	0	0	0	1	-1.5dB
0	0	0	0	1	0	1	0	-3dB
0	0	0	0	0	0	1	1	-4.5dB
⋮								
0	0	0	0	1	0	1	0	-15dB
0	0	0	0	1	0	1	1	-16.5dB
0	0	0	0	1	1	0	0	-18dB

**ANCILLARY DATA BUFFER**

**Address: 0x7E - 0xB5 (126 - 181)**

Type: RO

Software Reset: 0x00

Hardware Reset: 0x00

The STA015 contains 56 consecutive 8-bit registers corresponding to the maximum number of ancillary data that may be contained in MPEG frame.

The ANCCOUNT\_L and ANCOUNT\_H registers contain the number of ancillary data bits available within the current MPEG frame.

To perform ancillary data reading a status register (0xB6 - INTERRUPT\_STATUS\_REGISTER) is available: bit 0 of this register should be polled by the microcontroller in order to understand when new data are available.

0x7E	ANC_DATA_1
----	-----
----	-----
----	-----
----	-----
0xB5	ANC_DATA_56

0xB6	ISR
------	-----

**ISR**

**Address: 0xB6 (182)**

Type: R/W

Software Reset: 0x00

Hardware Reset: 0x00

MSB							LSB
b7	b6	b5	b4	b3	b2	b1	b0
X	X	X	X	X	X	X	0
							1

X = don't care;  
 0 = no ancillary data  
 1 = Ancillary Data Available

The ISR is used by the microcontroller to understand when a new ancillary data block is available. After all ancillary data has been retrieved this bit must be cleared.

**ADPCM\_CONFIG**

**Address: 0xB8 (184)**

Type: R/W

Software Reset: 0x00

Hardware Reset: 0x00

MSB						LSB	
b7	b6	b5	b4	b3	b2	b1	b0
X	X	X	X	AA1	AA0	ASM_EN	AFM_EN

This register controls ADPCM engine and how data must be compressed.

- AFM\_EN ADPCM Frame Mode Enable  
 0 = no frames (raw format)  
 1 = select the framed output format for ADPCM encoded data
- ASM\_EN: ADPCM Stereo Mode Enable  
 0 = Disable stereo mode  
 1 = Enable stereo mode
- AA0,AA1: ADPCM Algorithm selection  
 The ADPCM encoding/decoding algorithm can be selected according to the following table:

AA1	AA0	
0	0	DVI algorithm
0	1	G723-24 algorithm (24kbp/s)
1	0	G721 algorithm (32kbp/s)
1	1	G723-40 algorithm (40kbp/s)

The above bitrates refers to an 8 KHz 16 bits mono input stream.

Please note that 32KHz stereo mode is only available (both in encoding and decoding) with DVI algorithm

**GPSO\_ENABLE**

**Address: 0xB9 (185)**

Type: R/W

Software Reset: 0x00

Hardware Reset: 0x00

MSB							LSB
b7	b6	b5	b4	b3	b2	b1	b0
X	X	X	X	X	X	X	GEN

This register enable/disable the GPSO interface. Setting the GEN bit will enable the serial interface for ADPCM data retrieving. Reset GEN bit to disable GPSO interface.



**GPSO\_CONF**

**Address: 0xBA (186)**

Type: R/W

Software Reset: 0x00

Hardware Reset: 0x00

MSB							LSB
b7	b6	b5	b4	b3	b2	b1	b0
X	X	X	X	X	X	GRP	GSP

- GSP: GPSO clock polarity  
Using this bit the GPSO\_SCKR polarity can be controlled. Clearing GSP bit data on GPSO\_DATA line will be provided on the rising edge of GPSO\_SCKR (sampling on falling edge). Setting GSP bit data are provided on falling edge of GPSO\_SCKR (sampling on rising edge)
- GRP: GPSO Request Polarity  
This bit is used to determine the polarity of GPSO\_REQ signal. If GRP bit is cleared data are valid on GPSO\_REQ signal high. If this bit is set data are valid on GPSO\_REQ signal low

**ADC\_ENABLE**

**Address: 0xBB (187)**

Type: R/W

Software Reset: 0x00

Hardware Reset: 0x00

MSB							LSB
b7	b6	b5	b4	b3	b2	b1	b0
X	X	X	X	X	X	X	ADCEN

This register controls if the ADPCM data to be encoded comes from A/D interface or from MP3 bitstream input interface.  
If ADCEN bit is set data to be encoded comes from ADC interface, otherwise data comes from MP3 stream interface

**ADC\_CONF**

**Address: 0xBC (188)**

Type: R/W

Software Reset: 0x00

Hardware Reset: 0x00

MSB						LSB	
b7	b6	b5	b4	b3	b2	b1	b0
X	X	X	ALRCS	ALRCP	ASCP	ADC	AIIS

Using this register the ADC input interface can be configured as follow:

- AIIS: ADC I2S mode  
0 = sample word must be aligned with LRCK (no I<sup>2</sup>S mode)  
1 = sample word not aligned with LRCK (I<sup>2</sup>S compliant mode)
- ADC: ADC Data Config.  
0 = sample word is LSB first  
1 = sample word is MSB first
- ASCP: ADC Serial Clock Polarity  
0 = Data is sampled on rising edge  
1 = Data is sampled an falling edge
- ALRCP: ADC Left/Right Clock Polarity
- ALRCS: ADC Left/Right Clock Start value. This two bits permit to determine Left/Right clock usage according to the following table:

ALRCP	ALRCS	LEFT/RIGHT COUPLE	
0	0	(Data1, Data2)	(Data3, Data4)
1	0	(0, 1)	(2, 3)
0	1	(0, 1)	(2, 3)
1	1	(1, 2)	(3, 4)

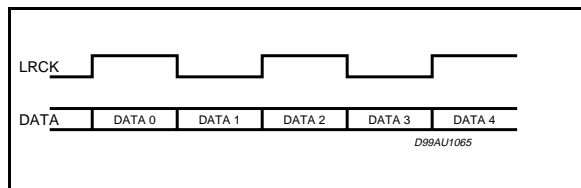



**ADPCM\_FRAME\_SIZE**

**Address: 0xBD (189)**

Type: R/W

Software Reset: 0x13

Hardware Reset: 0x00

MSB							LSB
b7	b6	b5	b4	b3	b2	b1	b0
AFS7	AFS6	AFS5	AFS4	AFS3	AFS2	AFS1	AFS1

The ADPCM frame size may be adjusted to match a trade-off between the bitrate overhead and the frame length. The frame size (in bytes) is calculated as follow:

$$\text{FRAME size} = (\text{ADPCM\_FRAME\_SIZE} * 90) + 108$$

The frame starts with a 12 bytes header:

- 6 bytes for DVI algorithm
- 96 bytes for G726 pack algorithms

**ADPCM\_INT\_CFG**

**Address: 0xBE (190)**

Type: R/W

Software Reset: 0x0B

Hardware Reset: 0x00

MSB							LSB
b7	b6	b5	b4	b3	b2	b1	b0
INTL	INTL	INTL	INTL	INTL	INTL	INTL	X
6	5	4	3	2	1	0	

Using this register the ADPCM interrupt capability can be properly configured.

INTL0 - Interrupt Length  
INTL6

The interrupt length can be programmed, using this bits, from 0 up to 128 system clock cycles

**GPIO\_CONF**

**Address: 0xBF (191)**

Type: R/W

Software Reset: 0x00

Hardware Reset: 0x00

MSB							LSB
b7	b6	b5	b4	b3	b2	b1	b0
X	X	X	X	X	X	GOSP	GISP

This register controls how data are strobed on the GPIO interface.

GISP: GPIO Strobe Polarity in INPUT mode

0 = data strobed an falling edge

1 = data strobed on rising edge

GOSP: GPIO Strobe Polarity in OUTPUT mode

0 = non inverted

1 = inverted

**ADC\_WLEN**

**Address: 0xC0 (192)**

Type: R/W

Software Reset: 0x0F

Hardware Reset: 0x0F

MSB							LSB
b7	b6	b5	b4	b3	b2	b1	b0
X	X	X	AWL4	AWL3	AWL2	AWL1	AWL0

To select ADC word length AWL4 through AWL0 bits can be used. This 5 bit value must contain the size of the significant data bits minus one.

**ADC\_WPOS**

**Address: 0xC1 (193)**

Type: R/W

Software Reset: 0x00

Hardware Reset: 0x00

MSB							LSB
b7	b6	b5	b4	b3	b2	b1	b0
X	X	X	AWP4	AWP3	AWP2	AWP1	AWP0

These bits specify the position of the sample word referred to the LRCK slot boundary. Bit AWP0 thru AWP4 must be programmed with the number of bits to ignore after the sample word.

**ADPCM\_SKIP\_FRAME**

**Address: 0xC2 (194)**

Type: R/W

Software Reset: 0x00

Hardware Reset: 0x00

MSB							LSB
b7	b6	b5	b4	b3	b2	b1	b0
ASF7	ASF6	ASF5	ASF4	ASF3	ASF2	ASF1	ASF0

This register is useful when decoding ADPCM frame-based streams in order to skip the specified number of frames. The content of the register will automatically be decremented on each new frame and the skip process will continue until the content reaches zero.



5.3. I/O CELL DESCRIPTION (pinout relative to TQFP44 package)

1) CMOS Tristate Output Pad Buffer, 4mA, with Slew Rate Control / Pin numbers 2, 4, 13, 27, 33, 42, 44

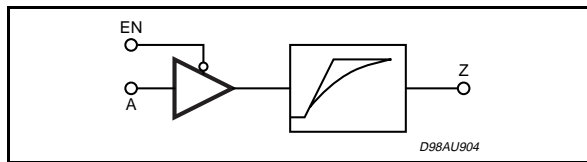

OUTPUT PIN	MAX LOAD
Z	100pF

2) CMOS Bidir Pad Buffer, 4mA, with Slew Rate Control / Pin numbers 3, 31

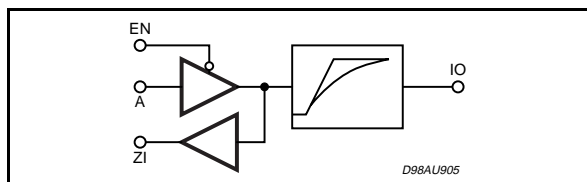

INPUT PIN	CAPACITANCE	OUTPUT PIN	MAX LOAD
IO	5pF	IO	100pF

3) CMOS Input Pad Buffer / Pin numbers 24, 26, 32, 34, 36, 40

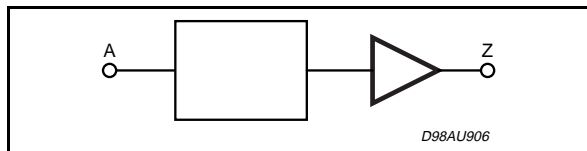

INPUT PIN	CAPACITANCE
A	3.5pF

4) CMOS Input Pad Buffer with Active Pull-Up / Pin numbers 22, 25, 28, 38

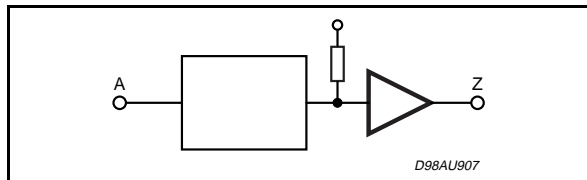

INPUT PIN	CAPACITANCE
A	3.5pF

5) CMOS Schmitt Trigger Bidir Pad Buffer with active Pull-up, 4mA, with slew rate control / Pin numbers 14, 16, 18, 20, 35, 37, 39, 41, 43

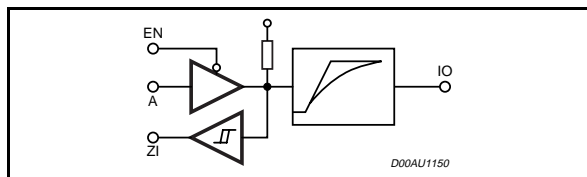

INPUT PIN	CAPACITANCE	OUTPUT PIN	MAX LOAD
IO	5pF	IO	100pF

5.4. TIMING DIAGRAMS

5.4.1. Audio DAC Interface

a) OCLK in output. The audio PLL is used to clock the DAC

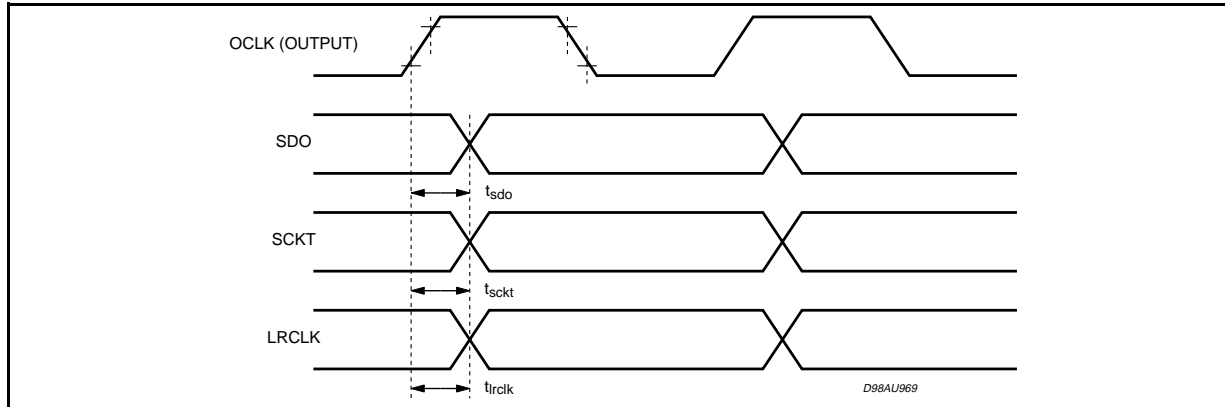

$$t_{sdo} = 3.5 + \text{pad\_timing}(\text{Cload\_SDO}) - \text{pad\_timing}(\text{Cload\_OCLK})$$

$$t_{sckt} = 4 + \text{pad\_timing}(\text{Cload\_SCKT}) - \text{pad\_timing}(\text{Cload\_OCLK})$$

$$t_{lrckt} = 3.5 + \text{pad\_timing}(\text{Cload\_LRCKT}) - \text{pad\_timing}(\text{Cload\_OCLK})$$

Pad-timing versus load

Load (pF)	Pad_timing
25	2.90ns
50	3.82ns
75	4.68ns
100	5.52ns

Clload\_XXX is the load in pF on the XXX output. pad\_timing (Clload\_XXX) is the propagation delay added to the XXX pad due to the load.

b) OCLK in input.

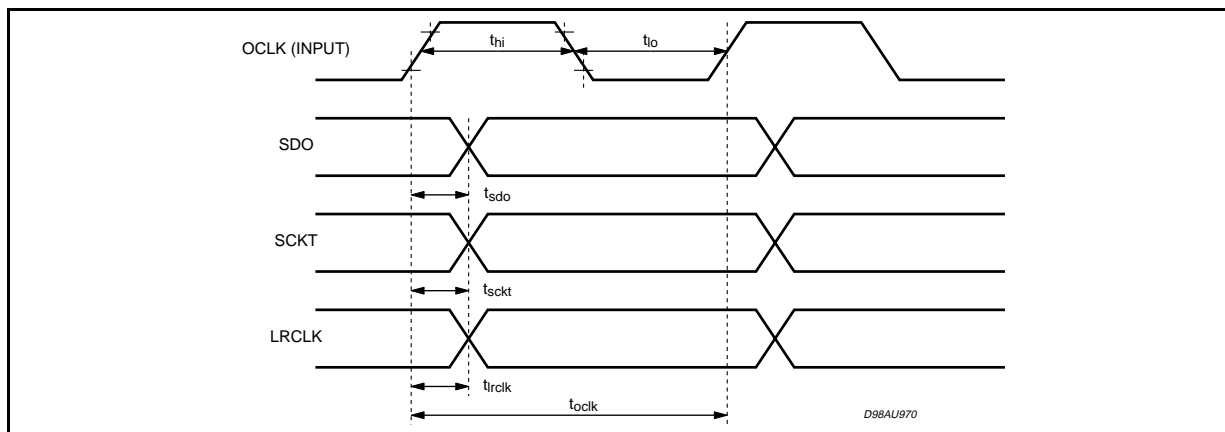

$$t_{hi} \text{ min} = 3\text{ns}$$

$$t_{lo} \text{ min} = 3\text{ns}$$

$$t_{ockl} \text{ min} = 25\text{ns}$$

$$t_{sdo} = 5.5 + \text{pad\_timing}(\text{Clload\_SDO}) \text{ ns}$$

$$t_{sckt} = 6 + \text{pad\_timing}(\text{Clload\_SCKT}) \text{ ns}$$

$$t_{lrckt} = 5.5 + \text{pad\_timing}(\text{Clload\_LRCKT}) \text{ ns}$$

5.4.2. Bitstream input interface (SDI, SCKR, BIT\_EN) SCL\_POL = 0

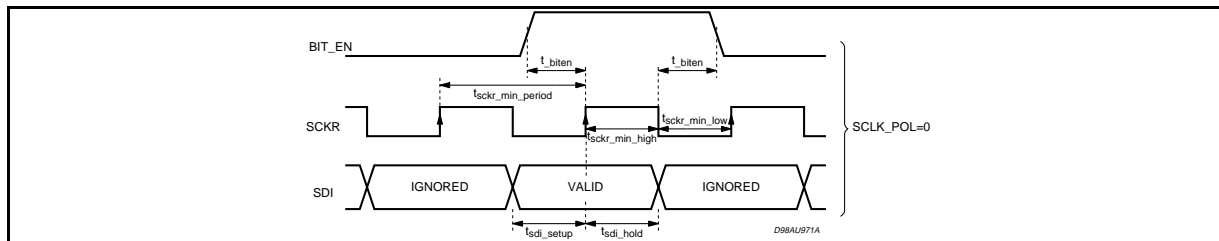

5.4.2. Bitstream input interface (SDI, SCKR, BIT\_EN) SCL\_POL = 1

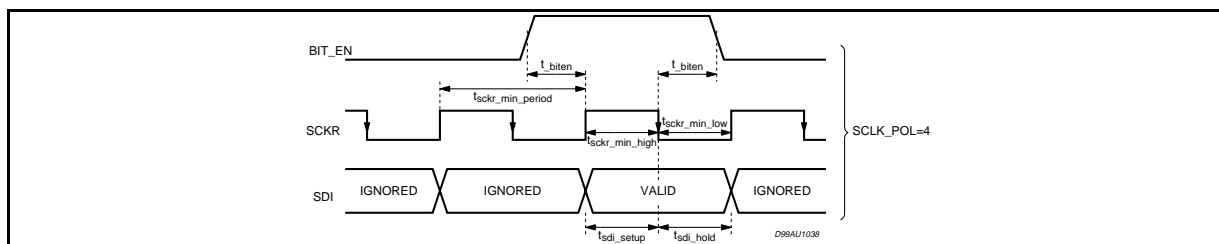

- tsdi\_setup\_min = 2ns
- tsdi\_hold\_min = 3ns
- tsckr\_min\_hi = 10ns
- tsckr\_min\_low = 10ns
- tsckr\_min\_lperiod = 50ns
- t\_biten (min) = 2ns

5.4.3. SRC\_INT

This is an asynchronous input used in "broadcast" mode.  
 SRC\_INT is active low

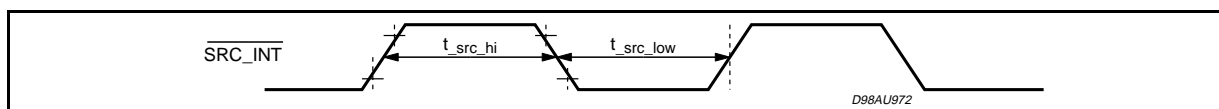

- t\_src\_low min duration is 50ns (1DSP clock period)
- t\_src\_high min duration is 50ns (1DSP clock period)

5.4.4. XTI,XTO and CLK\_OUT timings

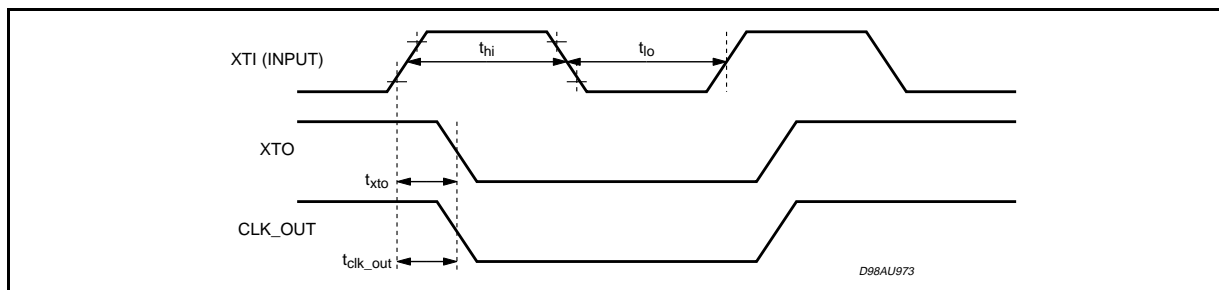

- txto = 1.40 + pad\_timing (Cload\_XTO) ns
- tclk\_out = 4 + pad\_timing (Cload\_CLK\_OUT) ns

Note: In "multimedia" mode, the CLK\_OUT pad is DATA\_REQ. In that case, no timing is given between the XTI input and this pad.

5.4.5. RESET

The Reset min duration ( $t_{reset\_low\_min}$ ) is 100ns

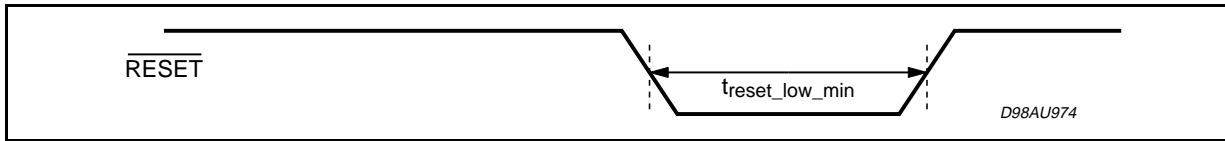

5.5. CONFIGURATION FLOW EXAMPLE

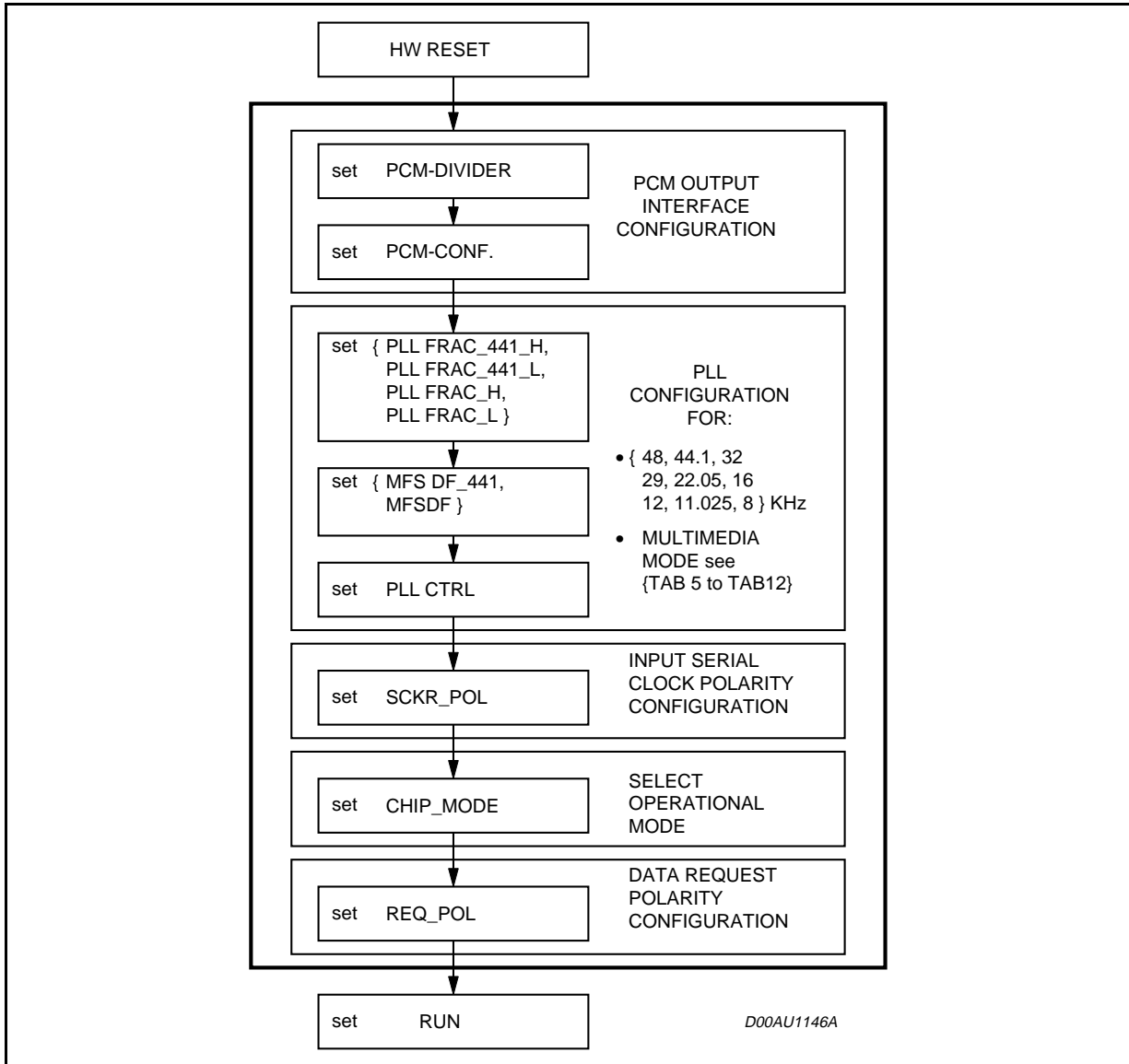

**Table 5:**  
 PLL Configuration Sequence For  
 10MHz Input Clock  
 256 Oversampling Clock

REGISTER ADDRESS	NAME	VALUE
6	reserved	18
11	reserved	3
97	MFSDF (x)	15
80	MFSDF-441	16
101	PLLFRAC-H	169
82	PLLFRAC-441-H	49
100	PLLFRAC-L	42
81	PLLFRAC-441-L	60
5	PLLCTRL	161

**Table 7:**  
 PLL Configuration Sequence For  
 14.31818MHz Input Clock  
 256 Oversampling Rathio

REGISTER ADDRESS	NAME	VALUE
6	reserved	12
11	reserved	3
97	MFSDF (x)	15
80	MFSDF-441	16
101	PLLFRAC-H	187
82	PLLFRAC-441-H	103
100	PLLFRAC-L	58
81	PLLFRAC-441-L	119
5	PLLCTRL	161

**Table 6:**  
 PLL Configuration Sequence For  
 10MHz Input Clock  
 384 Oversampling Rathio

REGISTER ADDRESS	NAME	VALUE
6	reserved	17
11	reserved	3
97	MFSDF (x)	9
80	MFSDF-441	10
101	PLLFRAC-H	110
82	PLLFRAC-441-H	160
100	PLLFRAC-L	152
81	PLLFRAC-441-L	186
5	PLLCTRL	161

**Table 8:**  
 PLL Configuration Sequence For  
 14.31818MHz Input Clock  
 384 Oversampling Rathio

REGISTER ADDRESS	NAME	VALUE
6	reserved	11
11	reserved	3
97	MFSDF (x)	6
80	MFSDF-441	7
101	PLLFRAC-H	3
82	PLLFRAC-441-H	157
100	PLLFRAC-L	211
81	PLLFRAC-441-L	157
5	PLLCTRL	161

**Table 9:**  
PLL Configuration Sequence For  
14.31818MHz Input Clock  
512 Oversampling Ratio

REGISTER ADDRESS	NAME	VALUE
6	reserved	11
11	reserved	3
97	MFSDF (x)	6
80	MFSDF-441	7
101	PLLFRACT-H	3
82	PLLFRACT-441-H	157
100	PLLFRACT-L	211
81	PLLFRACT-441-L	157
5	PLLCTRL	161

**Table 11:**  
PLL Configuration Sequence For  
14.7456MHz Input Clock  
384 Oversampling Ratio

REGISTER ADDRESS	NAME	VALUE
6	reserved	10
11	reserved	3
97	MFSDF (x)	8
80	MFSDF-441	9
101	PLLFRACT-H	64
82	PLLFRACT-441-H	124
100	PLLFRACT-L	0
81	PLLFRACT-441-L	0
5	PLLCTRL	161

**Table 10:**  
PLL Configuration Sequence For  
14.7456MHz Input Clock  
256 Oversampling Ratio

REGISTER ADDRESS	NAME	VALUE
6	reserved	12
11	reserved	3
97	MFSDF (x)	15
80	MFSDF-441	16
101	PLLFRACT-H	85
82	PLLFRACT-441-H	4
100	PLLFRACT-L	85
81	PLLFRACT-441-L	0
5	PLLCTRL	161

**Table 12:**  
PLL Configuration Sequence For  
14.7456MHz Input Clock  
512 Oversampling Ratio

REGISTER ADDRESS	NAME	VALUE
6	reserved	9
11	reserved	2
97	MFSDF (x)	5
80	MFSDF-441	6
101	PLLFRACT-H	0
82	PLLFRACT-441-H	184
100	PLLFRACT-L	0
81	PLLFRACT-441-L	0
5	PLLCTRL	161

**5.6. STA015 CONFIGURATION FILE FORMAT**

The STA015 Configuration File is an ASCII format. An example of the file format is the following:

```
58  1
42  4
128 15
.....
```

It is a sequence of rows and each one can be interpreted as an I<sup>2</sup>C command.

The first part of the row is the I<sup>2</sup>C address (register) and the second one is the I<sup>2</sup>C data (value).

To download the STA015 configuration file into the device, a sequence of write operation to STA015 I<sup>2</sup>C interface must be performed.

The following program describes the I<sup>2</sup>C routine to be implemented for the configuration driver:

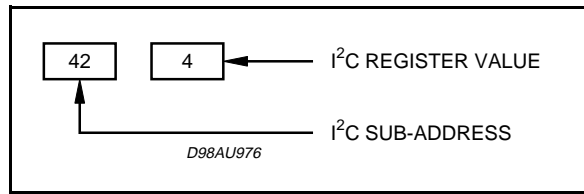

**STA015 Configuration Code (pseudo code)**

download cfg - file

```
{
  fopen (cfg_file);
  fp:=1;          /*set file pointer to first row */

  do {
    I2C_start_cond;      /* generate I2C start condition for STA015 device address */
    I2C_write_dev_addr;  /* write STA015 device address */
    I2C_write_subaddress (fp); /* write subaddress */
    I2C_write_data (fp);  /* write data */
    I2C_stop_cond;      /* generate I2C stop condition */
    fp++;              /* update pointer to new file row */
  }
  while (!EDF)        /* repeat until End of File */
}                    /* End routine */
```

Note:1

STA015 is a device based on an integrated DSP core. Some of the I2C registers default values are loaded after an internal DSP boot operation. The bootstrap time is 60 micro second. Only after this time length, the data in the register can be considered stable.

Note 2:

Refer also to the application note AN1250



DIM.	mm			inch		
	MIN.	TYP.	MAX.	MIN.	TYP.	MAX.
A			2.65			0.104
a1	0.1		0.3	0.004		0.012
b	0.35		0.49	0.014		0.019
b1	0.23		0.32	0.009		0.013
C		0.5			0.020	
c1	45° (typ.)					
D	17.7		18.1	0.697		0.713
E	10		10.65	0.394		0.419
e		1.27			0.050	
e3		16.51			0.65	
F	7.4		7.6	0.291		0.299
L	0.4		1.27	0.016		0.050
S	8° (max.)					

**OUTLINE AND MECHANICAL DATA**

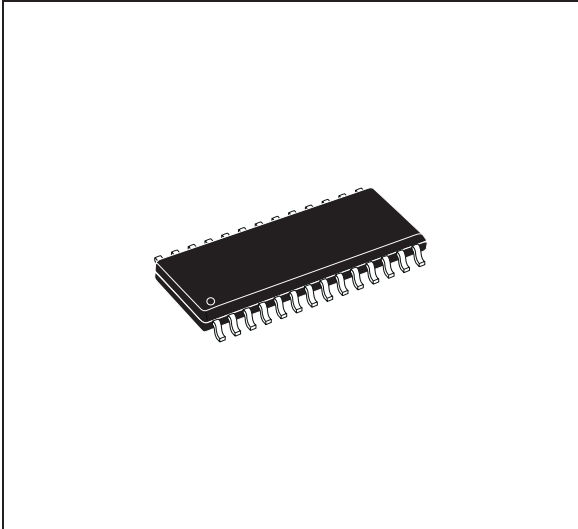

**SO28**

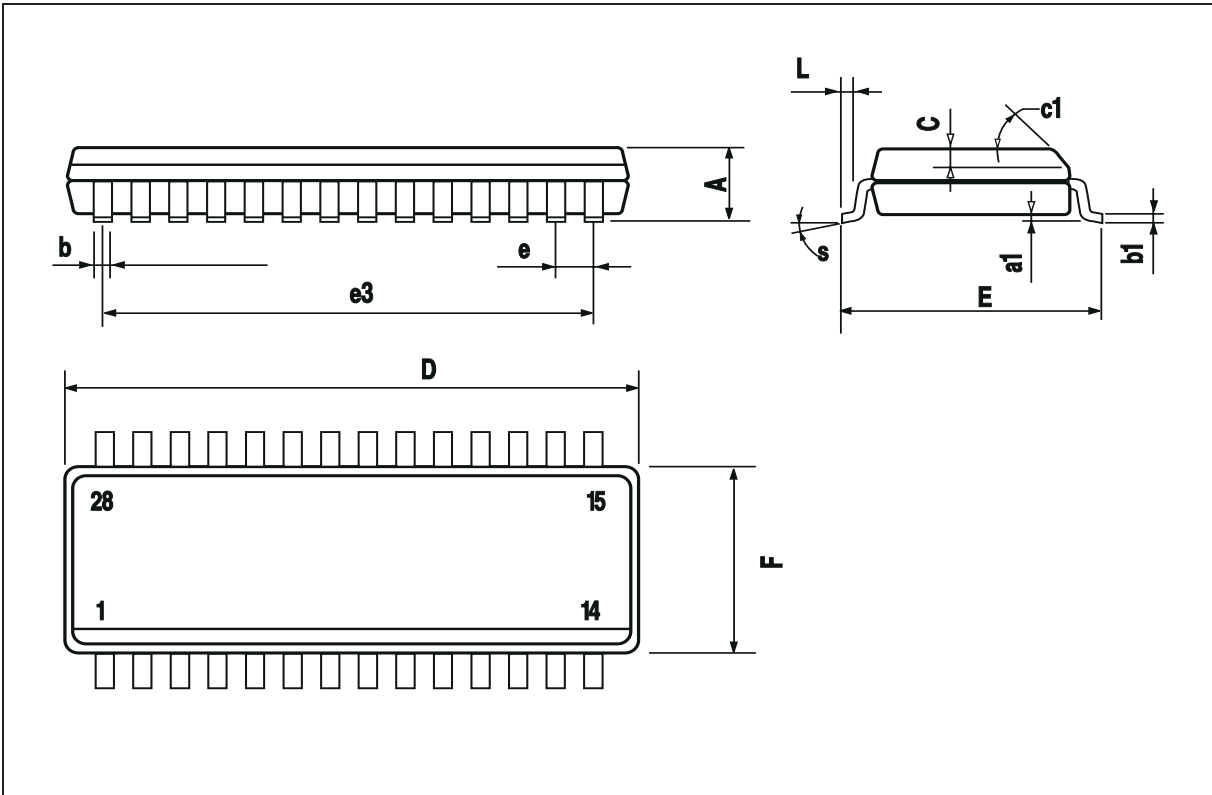

DIM.	mm			inch		
	MIN.	TYP.	MAX.	MIN.	TYP.	MAX.
A			1.60			0.063
A1	0.05		0.15	0.002		0.006
A2	1.35	1.40	1.45	0.053	0.055	0.057
B	0.30	0.37	0.45	0.012	0.014	0.018
C	0.09		0.20	0.004		0.008
D		12.00			0.472	
D1		10.00			0.394	
D3		8.00			0.315	
e		0.80			0.031	
E		12.00			0.472	
E1		10.00			0.394	
E3		8.00			0.315	
L	0.45	0.60	0.75	0.018	0.024	0.030
L1		1.00			0.039	
K	0°(min.), 3.5°(typ.), 7°(max.)					

**OUTLINE AND MECHANICAL DATA**

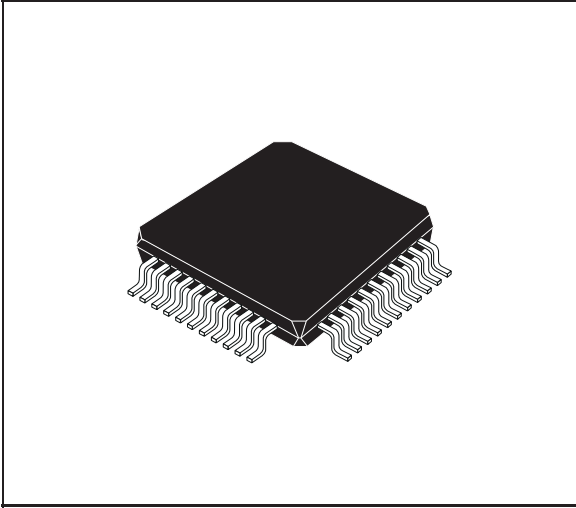

**TQFP44 (10 x 10)**

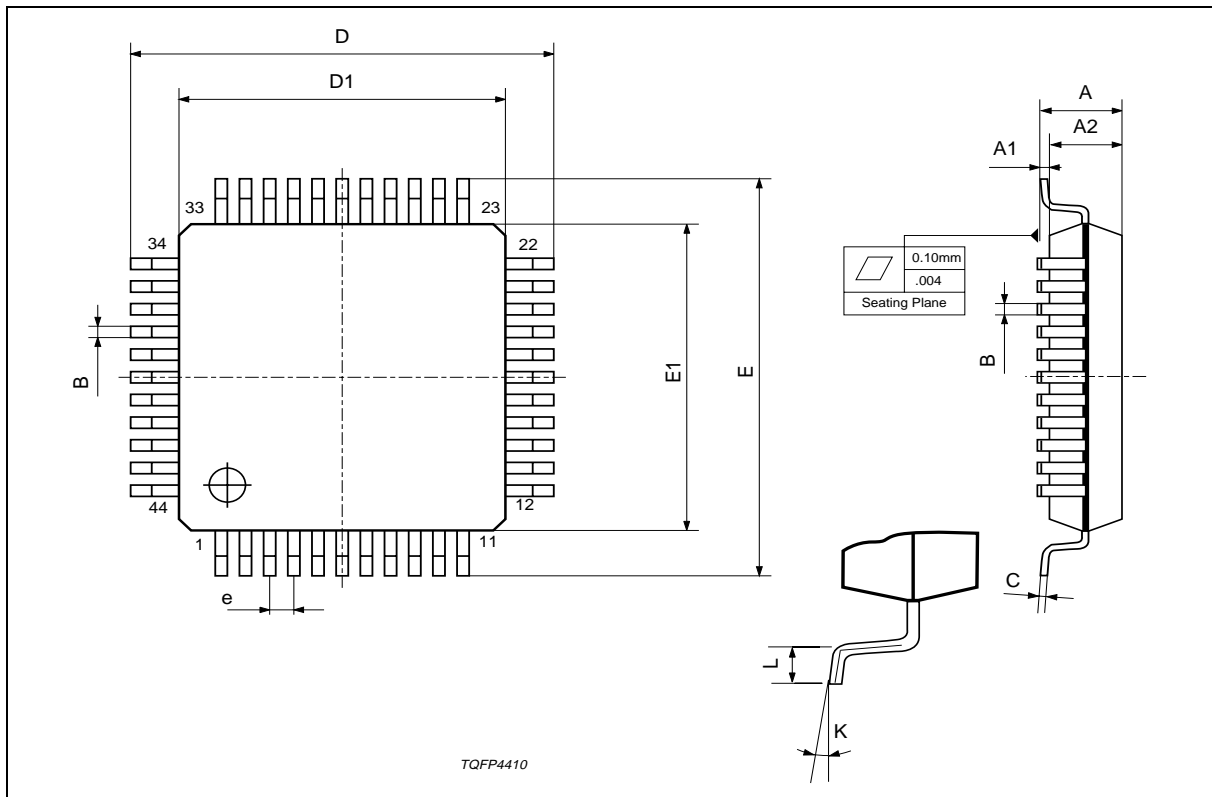

DIM.	mm			inch		
	MIN.	TYP.	MAX.	MIN.	TYP.	MAX.
A			1.700			0.067
A1	0.350	0.400	0.450	0.014	0.016	0.018
A2		1.100			0.043	
b		0.500			0.20	
D		8.000			0.315	
D1		5.600			0.220	
e		0.800			0.031	
E		8.000			0.315	
E1		5.600			0.220	
f		1.200			0.047	

**OUTLINE AND MECHANICAL DATA**

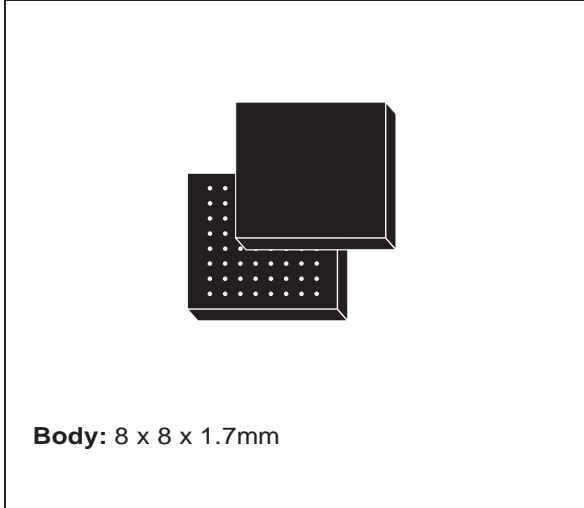

**LFBGA64**

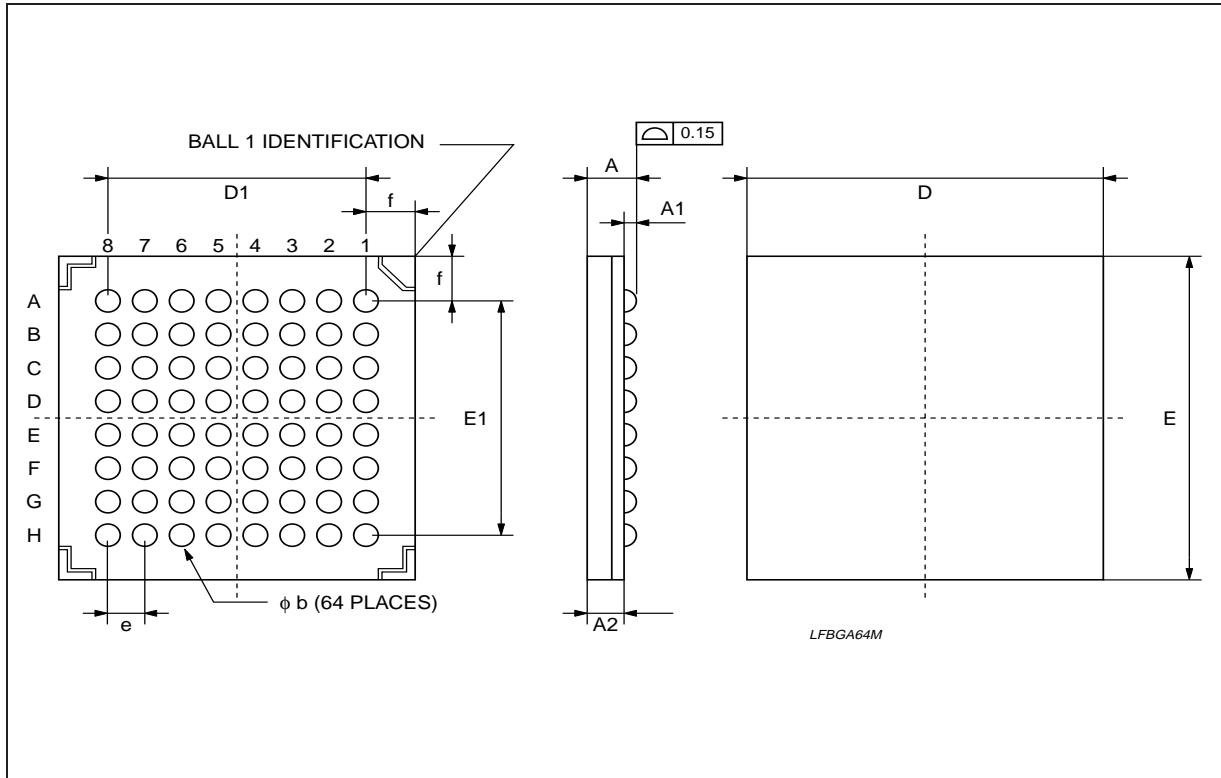

Information furnished is believed to be accurate and reliable. However, STMicroelectronics assumes no responsibility for the consequences of use of such information nor for any infringement of patents or other rights of third parties which may result from its use. No license is granted by implication or otherwise under any patent or patent rights of STMicroelectronics. Specification mentioned in this publication are subject to change without notice. This publication supersedes and replaces all information previously supplied. STMicroelectronics products are not authorized for use as critical components in life support devices or systems without express written approval of STMicroelectronics.

The ST logo is a registered trademark of STMicroelectronics

© 2000 STMicroelectronics – Printed in Italy – All Rights Reserved

STMicroelectronics GROUP OF COMPANIES

Australia - Brazil - China - Finland - France - Germany - Hong Kong - India - Italy - Japan - Malaysia - Malta - Morocco -  
Singapore - Spain - Sweden - Switzerland - United Kingdom - U.S.A.

<http://www.st.com>