



TDE1890 TDE1891

2A HIGH-SIDE DRIVER INDUSTRIAL INTELLIGENT POWER SWITCH

- 2A OUTPUT CURRENT
- 18V TO 35V SUPPLY VOLTAGE RANGE
- INTERNAL CURRENT LIMITING
- THERMAL SHUTDOWN
- OPEN GROUND PROTECTION
- INTERNAL NEGATIVE VOLTAGE CLAMPING TO $V_s - 50V$ FOR FAST DEMAGNETIZATION
- DIFFERENTIAL INPUTS WITH LARGE COMMON MODE RANGE AND THRESHOLD HYSTERESIS
- UNDERVOLTAGE LOCKOUT WITH HYSTERESIS
- OPEN LOAD DETECTION
- TWO DIAGNOSTIC OUTPUTS
- OUTPUT STATUS LED DRIVER

DESCRIPTION

The TDE1890/1891 is a monolithic Intelligent Power Switch in Multipower BCD Technology, for

MULTIPOWER BCD TECHNOLOGY

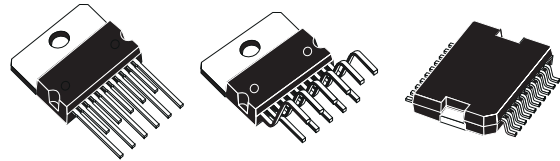

MULTIWATT11 MULTIWATT11V PowerSO20
(In line)

ORDERING NUMBERS:

TDE1891L TDE1890V TDE1890D
 TDE1891V

driving inductive or resistive loads. An internal Clamping Diode enables the fast demagnetization of inductive loads.

Diagnostic for CPU feedback and extensive use of electrical protections make this device extremely rugged and specially suitable for industrial automation applications.

BLOCK DIAGRAM

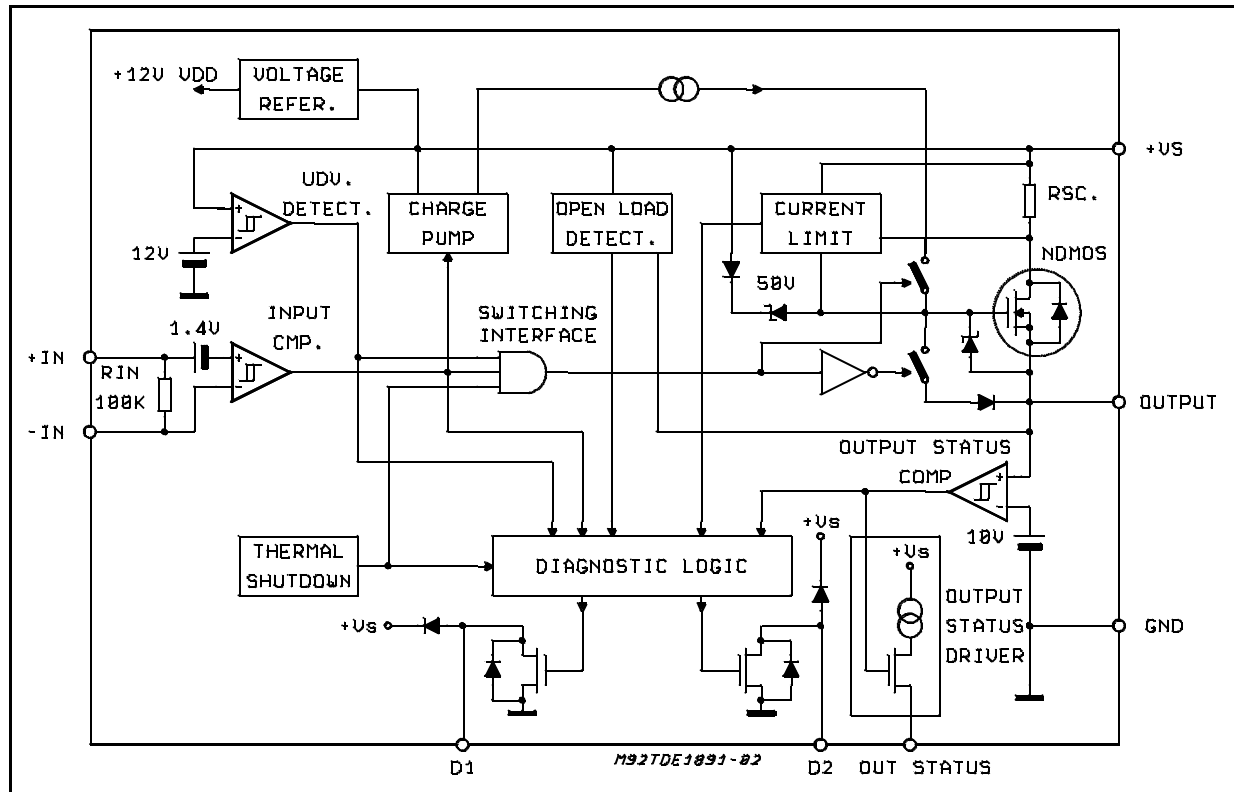

TDE1890 - TDE1891

PIN CONNECTION (Top view)

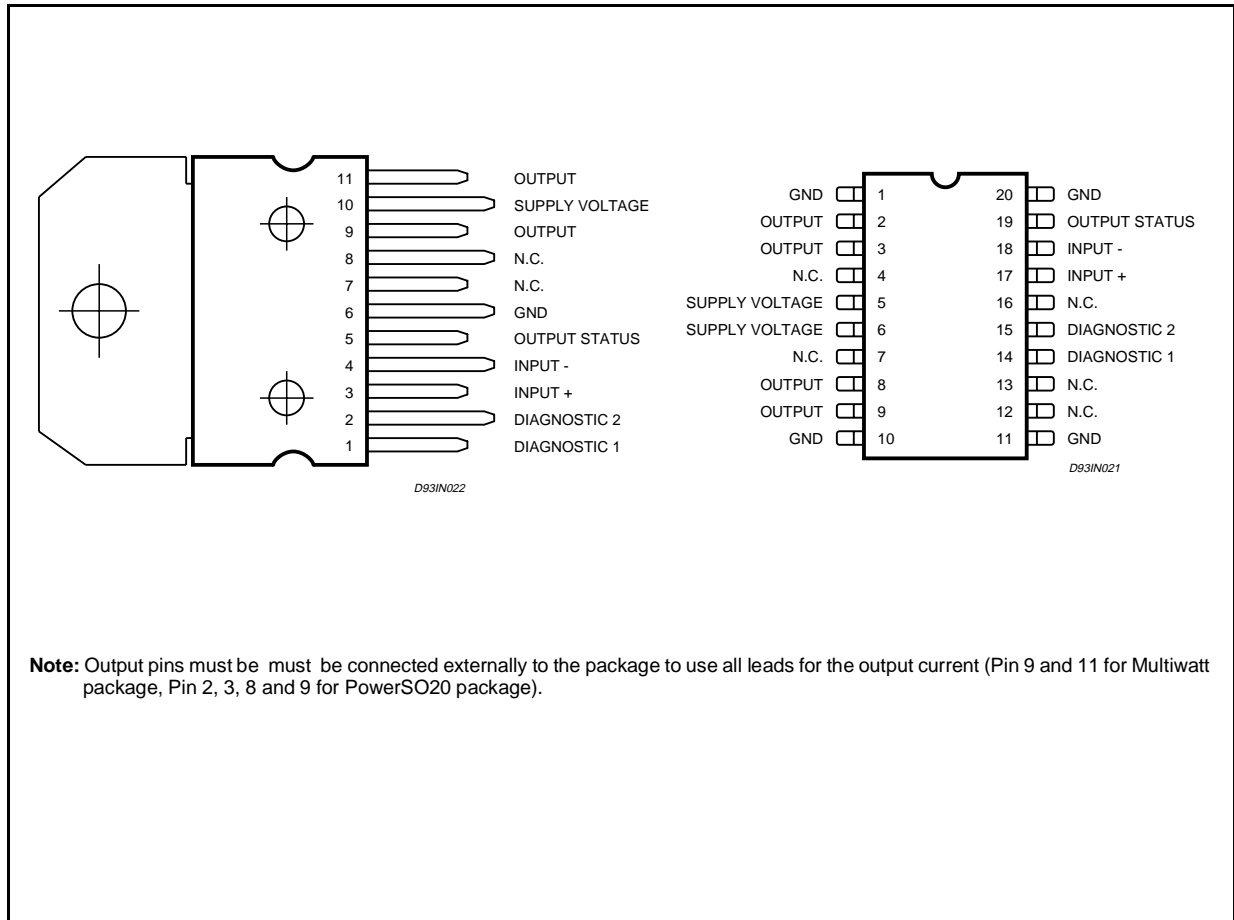

ABSOLUTE MAXIMUM RATINGS

Symbol	Parameter	Value	Unit
V_S	Supply Voltage (Pin 10) ($T_W < 10\text{ms}$)	50	V
$V_S - V_O$	Supply to Output Differential Voltage. See also V_{CI} (Pins 10 - 9)	internally limited	V
V_i	Input Voltage (Pins 3/4)	-10 to $V_S + 10$	V
V_i	Differential Input Voltage (Pins 3 - 4)	43	V
I_i	Input Current (Pins 3/4)	20	mA
I_O	Output Current (Pin 9). See also ISC (Pin 9)	internally limited	A
P_{tot}	Power Dissipation. See also THERMAL CHARACTERISTICS.	internally limited	W
T_{op}	Operating Temperature Range (T_{amb})	-25 to +85	°C
T_{stg}	Storage Temperature	-55 to 150	°C
E_i	Energy Induct. Load $T_J = 85^\circ\text{C}$	1	J

THERMAL DATA

Symbol	Description		Multiwatt	PowerSO20	Unit
$R_{th\ j-case}$	Thermal Resistance Junction-case	Max.	1.5	1.5	°C/W
$R_{th\ j-amb}$	Thermal Resistance Junction-ambient	Max.	35	-	°C/W

ELECTRICAL CHARACTERISTICS ($V_S = 24V$; $T_{amb} = -25$ to $+85^\circ C$, unless otherwise specified)

Symbol	Parameter	Test Condition	Min.	Typ.	Max.	Unit
V_{smin}	Supply Voltage for Valid Diagnostics	$I_{diag} > 0.5mA$; $V_{dgt} = 1.5V$	9		35	V
V_S	Supply Voltage (operative)		18	24	35	V
I_q	Quiescent Current $I_{out} = I_{os} = 0$	V_{il} V_{ih}		3 5	7 8	mA mA
V_{sth1}	Undervoltage Threshold 1	(See fig. 1), $T_{amb} = 0$ to $+85^\circ C$	11		15.5	V
V_{sth2}	Undervoltage Threshold 2					V
V_{shys}	Supply Voltage Hysteresis					1
I_{sc}	Short Circuit Current	$V_S = 18$ to $35V$; $R_L = 2\Omega$	2.6		5	A
V_{don}	Output Voltage Drop	$I_{out} = 2.0A$ $T_j = 25^\circ C$ $T_j = 125^\circ C$ $I_{out} = 2.5A$ $T_j = 25^\circ C$ $T_j = 125^\circ C$		360 575 440 700	500 800 575 920	mV mV mV mV
I_{oslk}	Output Leakage Current	$V_i = V_{il}$; $V_o = 0V$			500	μA
V_{ol}	Low State Out Voltage	$V_i = V_{il}$; $R_L = \infty$		0.8	1.5	V
V_{cl}	Internal Voltage Clamp ($V_S - V_o$)	$I_o = 1A$ Single Pulsed: $T_p = 300\mu s$	48	53	58	V
I_{old}	Open Load Detection Current	$V_i = V_{ih}$; $T_{amb} = 0$ to $+85^\circ C$	0.5		9.5	mA
V_{id}	Common Mode Input Voltage Range (Operative)	$V_S = 18$ to $35V$, $V_S - V_{id} < 37V$	-7		15	V
I_{ib}	Input Bias Current	$V_i = -7$ to $15V$; $-I_n = 0V$	-250		250	μA
V_{ith}	Input Threshold Voltage	$V+In > V-In$	0.8	1.4	2	V
V_{iths}	Input Threshold Hysteresis Voltage	$V+In > V-In$	50		400	mV
R_{id}	Diff. Input Resistance	$0 < +In < +16V$; $-In = 0V$ $-7 < +In < 0V$; $-In = 0V$		400 150		K Ω K Ω
I_{lik}	Input Offset Current	$V+In = V-In$ +li $0V < V_i < 5.5V$ -li	-20 -75	-25	+20	μA μA
		$-In = GND$ +li $0V < V+In < 5.5V$ -li	-250	-125	+50	μA μA
		$+In = GND$ +li $0V < V-In < 5.5V$ -li	-100 -50	-30 -15		μA μA
V_{oth1}	Output Status Threshold 1 Voltage	(See fig. 1)			11.5	V
V_{oth2}	Output Status Threshold 2 Voltage	(See fig. 1)	8.5			V
V_{ohys}	Output Status Threshold Hysteresis	(See fig. 1)		0.7		V
I_{osd}	Output Status Source Current	$V_{out} > V_{oth1}$; $V_{os} = 2.5V$	2		4	mA
V_{osd}	Active Output Status Driver Drop Voltage	$V_S - V_{os}$; $I_{os} = 2mA$ $T_{amb} = -25$ to $+85^\circ C$			5	V
I_{oslk}	Output Status Driver Leakage Current	$V_{out} < V_{oth2}$; $V_{os} = 0V$ $V_S = 18$ to $35V$			25	μA
V_{dgl}	Diagnostic Drop Voltage	$D1 / D2 = L$; $I_{diag} = 0.5mA$ $D1 / D2 = L$; $I_{diag} = 3mA$			250 1.5	mV V
I_{dglk}	Diagnostic Leakage Current	$D1 / D2 = H$; $0 < V_{dg} < V_S$ $V_S = 15.6$ to $35V$			25	μA
V_{fdg}	Clamping Diodes at the Diagnostic Outputs. Voltage Drop to V_S	$I_{diag} = 5mA$; $D1 / D2 = H$			2	V

Note $V_{il} \leq 0.8V$, $V_{ih} \geq 2V$ @ ($V+In > V-In$)



TDE1890 - TDE1891

SOURCE DRAIN NDMOS DIODE

Symbol	Parameter	Test Condition	Min.	Typ.	Max.	Unit
V_{fsd}	Forward On Voltage	@ $I_{fsd} = 2.5A$		1	1.5	V
I_{fp}	Forward Peak Current	$t = 10ms; d = 20%$			6	A
t_{rr}	Reverse Recovery Time	$I_f = 2.5A$ $di/dt = 25A/\mu s$		200		ns
t_{fr}	Forward Recovery Time			100		ns

THERMAL CHARACTERISTICS

\emptyset Lim	Junction Temp. Protect.		135	150		°C
T_H	Thermal Hysteresis			30		°C

SWITCHING CHARACTERISTICS ($V_S = 24V; R_L = 12\Omega$)

t_{on}	Turn on Delay Time				200	μs
t_{off}	Turn off Delay Time				40	μs
t_d	Input Switching to Diagnostic Valid				200	μs

Note $V_{il} \leq 0.8V, V_{ih} \geq 2V$ @ ($V_{+In} > V_{-In}$)

Figure 1

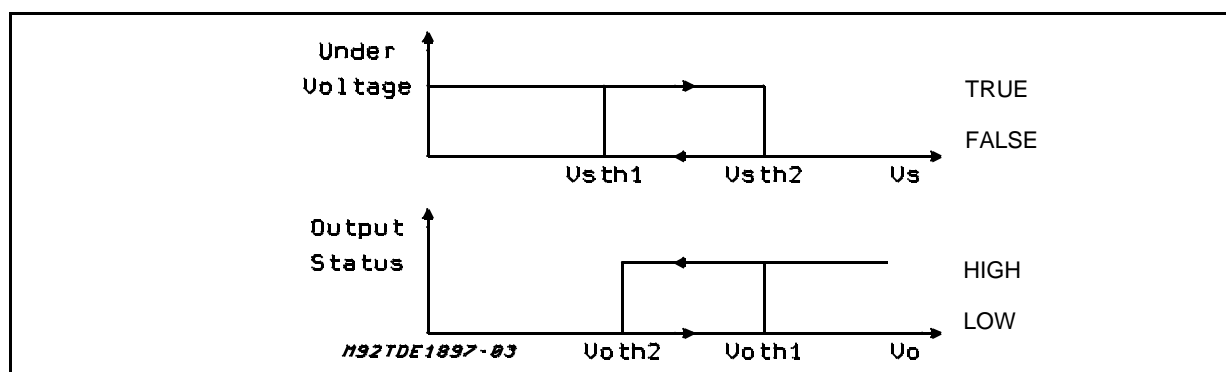

DIAGNOSTIC TRUTH TABLE

Diagnostic Conditions	Input	Output	Diag1	Diag2
Normal Operation	L	L	H	H
	H	H	H	H
Open Load Condition ($I_o < I_{oid}$)	L	L	H	H
	H	H	L	H
Short to V_S	L	H	L	H
	H	H	L	H
Short Circuit to Ground ($I_o = I_{sc}$) (**)	TDE1891	H	<H (*)	L
	TDE1890	H	H L	H H
Output DMOS Open	L	L	H	H
	H	L	L	H
Overtemperature	L	L	H	L
	H	L	H	L
Supply Undervoltage ($V_S < V_{sth2}$)	L	L	L	L
	H	L	L	L

(*) According to the intervention of the current limiting block.

(**) A cold lamp filament, or a capacitive load may activate the current limiting circuit of the IPS, when the IPS is initially turned on. TDE1891 uses Diag2 to signal such condition, TDE1890 does not.

APPLICATION INFORMATION**DEMAGNETIZATION OF INDUCTIVE LOADS**

An internal zener diode, limiting the voltage across the Power MOS to between 50 and 60V (V_{cl}), provides safe and fast demagnetization of inductive loads without external clamping devices.

The maximum energy that can be absorbed from an inductive load is specified as 1J (at $T_j = 85^\circ\text{C}$).

To define the maximum switching frequency three points have to be considered:

- 1) The total power dissipation is the sum of the On State Power and of the Demagnetization Energy multiplied by the frequency.
- 2) The total energy W dissipated in the device during a demagnetization cycle (fig. 2, 3) is:

$$W = V_{cl} \frac{L}{R_L} \left[I_o - \frac{V_{cl} - V_s}{R_L} \log \left(1 + \frac{V_s}{V_{cl} - V_s} \right) \right]$$

Where:

V_{cl} = clamp voltage;
 L = inductive load;
 R_L = resistive load;
 V_s = supply voltage;
 $I_o = I_{LOAD}$

- 3) In normal conditions the operating Junction temperature should remain below 125°C .

If the demagnetization energy exceeds the rated value, an external clamp between output and $+V_s$ must be externally connected (see fig. 5).

The external zener will be chosen with V_{zener} value lower than the internal V_{cl} minimum rated value and significantly (at least 10V) higher than the voltage that is externally supplied to pin 10, i.e. than the supply voltage.

Alternative circuit solutions can be implemented to divert the demagnetization stress from the TDE1890/1, if it exceeds 1J. In all cases it is recommended that at least 10V are available to demagnetize the load in the turn-off phase.

A clamping circuit connected between ground and the output pin is not recommended. An interruption of the connection between the ground of the load and the ground of the TDE1890/1 would leave the TDE1890/1 alone to absorb the full amount of the demagnetization energy.

Figure 2: Inductive Load Equivalent Circuit

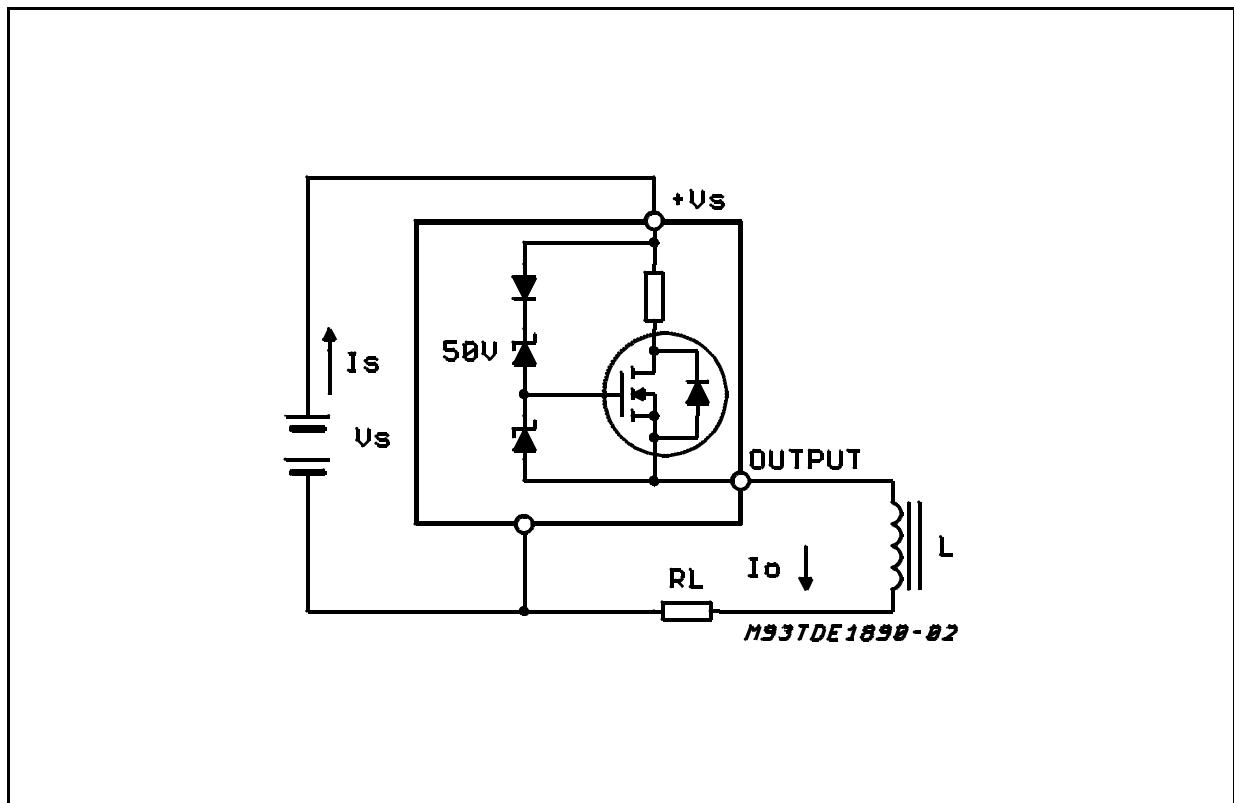

Figure 3: Demagnetization Cycle Waveforms

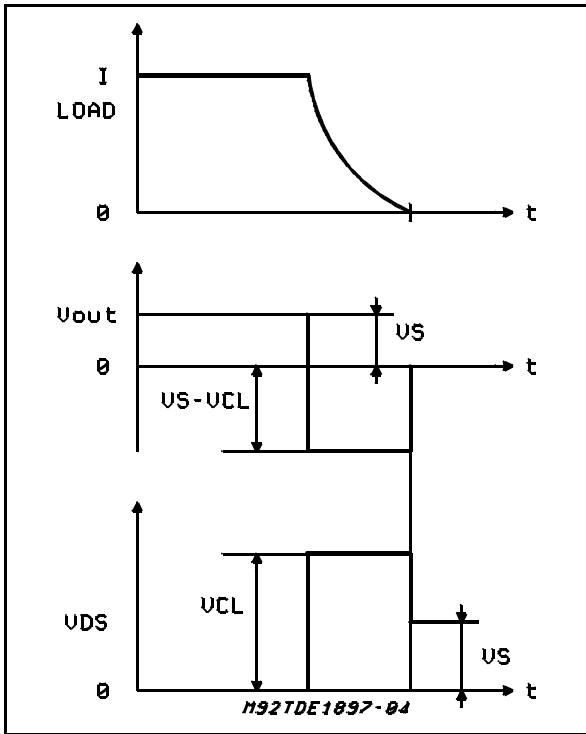

Figure 4: Normalized $R_{DS(on)}$ vs. Junction Temperature

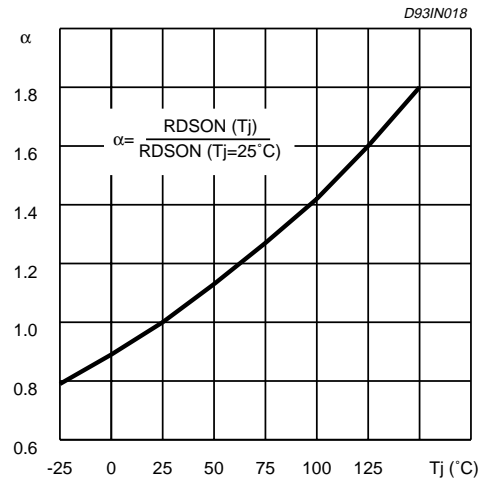
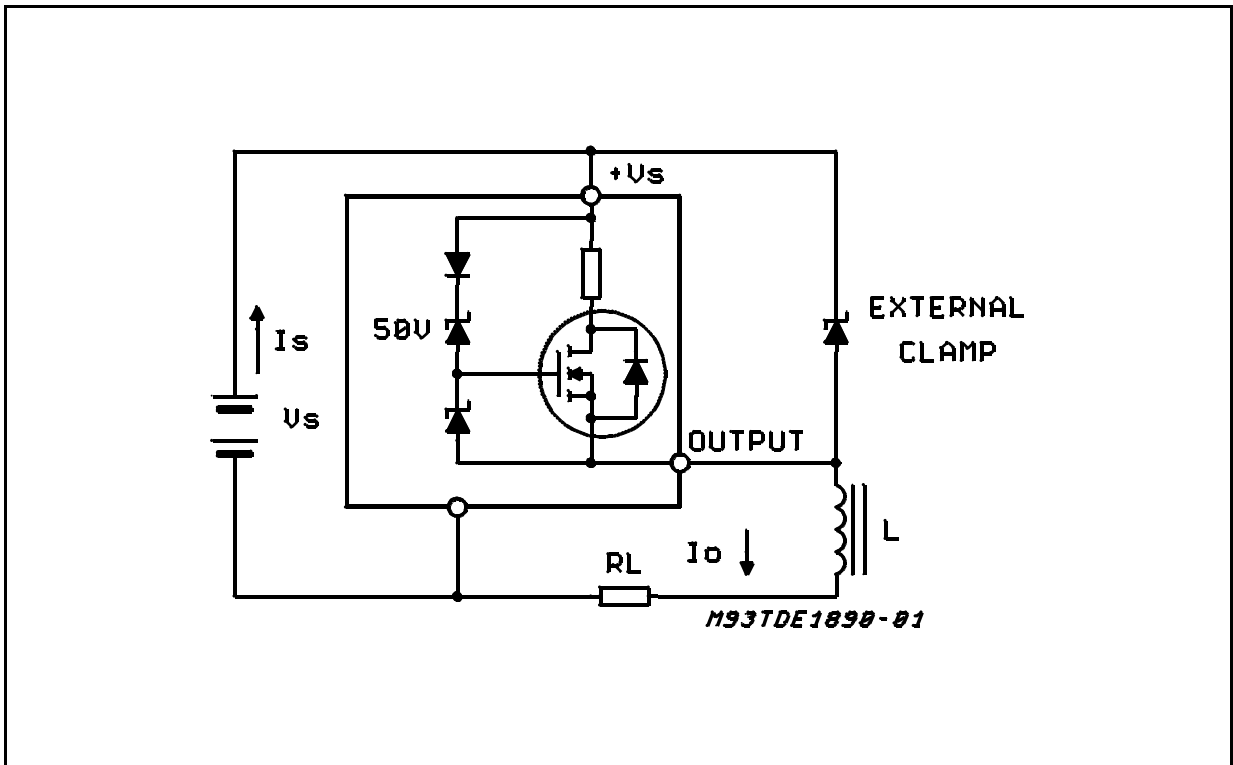

Figure 5.



WORST CONDITION POWER DISSIPATION IN THE ON-STATE

In IPS applications the maximum average power dissipation occurs when the device stays for a long time in the ON state. In such a situation the internal temperature depends on delivered current (and related power), thermal characteristics of the package and ambient temperature.

At ambient temperature close to upper limit (+85°C) and in the worst operating conditions, it is possible that the chip temperature could increase so much to make the thermal shutdown procedure untimely intervene.

Our aim is to find the maximum current the IPS can withstand in the ON state without thermal shutdown intervention, related to ambient temperature. To this end, we should consider the following points:

- 1) The ON resistance R_{DSON} of the output NDMOS (the real switch) of the device increases with its temperature. Experimental results show that silicon resistivity increases with temperature at a constant rate, rising of 60% from 25°C to 125°C. The relationship between R_{DSON} and temperature is therefore:

$$R_{DSON} = R_{DSON0} (1 + k) (T_j - 25)$$

where:

- T_j is the silicon temperature in °C
- R_{DSON0} is R_{DSON} at $T_j=25^\circ\text{C}$
- k is the constant rate ($k = 4.711 \cdot 10^{-3}$) (see fig. 4).

- 2) In the ON state the power dissipated in the device is due to three contributes:

- a) power lost in the switch:
 $P_{out} = I_{out}^2 \cdot R_{DSON}$ (I_{out} is the output current);
- b) power due to quiescent current in the ON state I_q , sunk by the device in addition to I_{out} : $P_q = I_q \cdot V_s$ (V_s is the supply voltage);
- c) an external LED could be used to visualize the switch state (OUTPUT STATUS pin). Such a LED is driven by an internal current source (delivering I_{os}) and therefore, if V_{os} is the voltage drop across the LED, the dissipated power is: $P_{os} = I_{os} \cdot (V_s - V_{os})$.

Thus the total ON state power consumption is given by:

$$P_{on} = P_{out} + P_q + P_{os} \quad (1)$$

In the right side of equation 1, the second and

the third element are constant, while the first one increases with temperature because R_{DSON} increases as well.

- 3) The chip temperature must not exceed Θ_{Lim} in order do not lose the control of the device. The heat dissipation path is represented by the thermal resistance of the system device-ambient (R_{th}). In steady state conditions, this parameter relates the power dissipated P_{on} to the silicon temperature T_j and the ambient temperature T_{amb} :

$$T_j - T_{amb} = P_{on} \cdot R_{th} \quad (2)$$

From this relationship, the maximum power P_{on} which can be dissipated without exceeding Θ_{Lim} at a given ambient temperature T_{amb} is:

$$P_{on} = \frac{\Theta_{Lim} - T_{amb}}{R_{th}}$$

Replacing the expression (1) in this equation and solving for I_{out} , we can find the maximum current versus ambient temperature relationship:

$$I_{outx} = \sqrt{\frac{\frac{\Theta_{Lim} - T_{amb}}{R_{th}} - P_q - P_{os}}{R_{DSONx}}}$$

where R_{DSONx} is R_{DSON} at $T_j=\Theta_{Lim}$. Of course, I_{outx} values are top limited by the maximum operative current I_{outx} (2A nominal). From the expression (2) we can also find the maximum ambient temperature T_{amb} at which a given power P_{on} can be dissipated:

$$T_{amb} = \Theta_{Lim} - P_{on} \cdot R_{th} = \Theta_{Lim} - (I_{out}^2 \cdot R_{DSONx} + P_q + P_{os}) \cdot R_{th}$$

In particular, this relation is useful to find the maximum ambient temperature T_{ambx} at which I_{outx} can be delivered:

$$T_{ambx} = \Theta_{Lim} - (I_{outx}^2 \cdot R_{DSONx} + P_q + P_{os}) \cdot R_{th} \quad (4)$$

Referring to application circuit in fig. 6, let us consider the worst case:

- The supply voltage is at maximum value of industrial bus (30V instead of the 24V nominal value). This means also that I_{outx} rises of 25% (2.5A instead of 2A).



TDE1890 - TDE1891

- All electrical parameters of the device, concerning the calculation, are at maximum values.
- Thermal shutdown threshold is at minimum value.

Therefore:

$V_S = 30V$, $R_{DS(ON)0} = 0.23\Omega$, $I_q = 8mA$, $I_{os} = 4mA$
 @ $V_{os} = 2.5V$, $\Theta_{Lim} = 135^\circ C$
 $R_{th(j-amb)} = 35^\circ C/W$

It follows:

$I_{outx} = 2.5A$, $R_{DS(ON)x} = 0.386\Omega$, $P_q = 240mW$,
 $P_{os} = 110mW$

From equation 4 we can see that, without any heatsink, it is not possible to operate in the ON steady state at the maximum current value. A derating curve for this case is reported in fig. 7. Using an external heatsink, in order to obtain a total R_{th} of $15^\circ C/W$, we obtain the derating curve reported in fig. 8.

Figure 6: Application Circuit

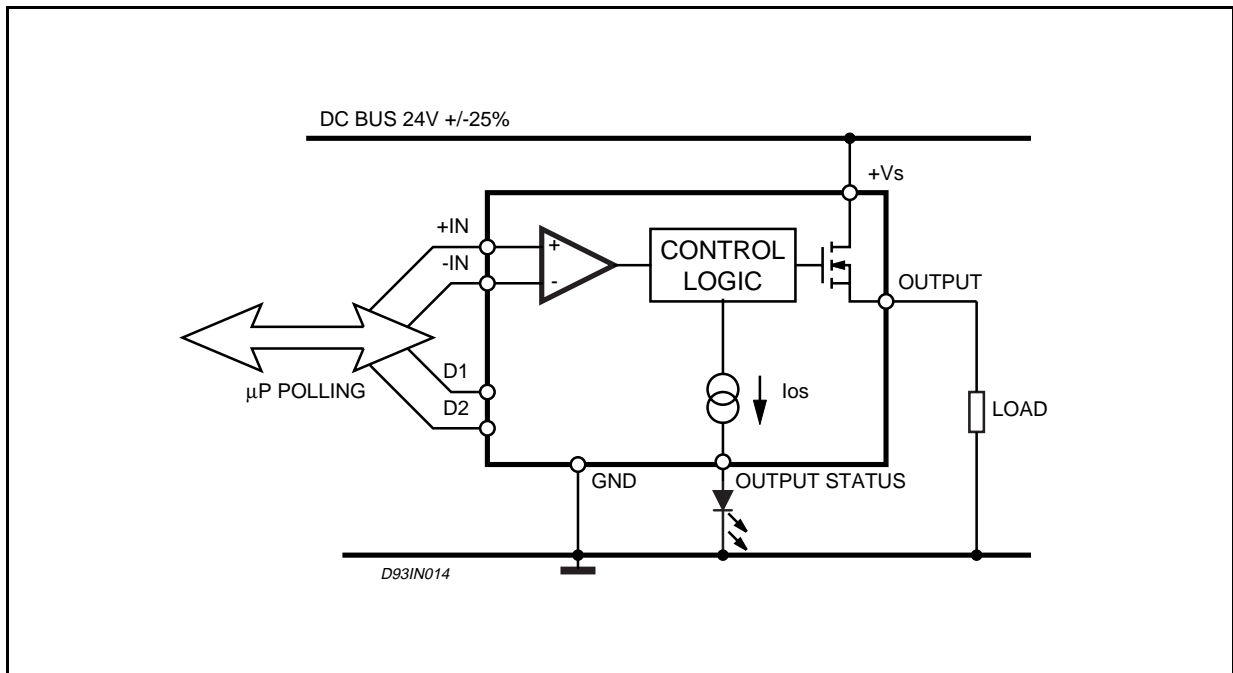

Figure 7: Max. Output Current vs. Ambient Temperature (Multiwatt without heatsink, $R_{th(j-amb)} = 35^\circ C/W$)

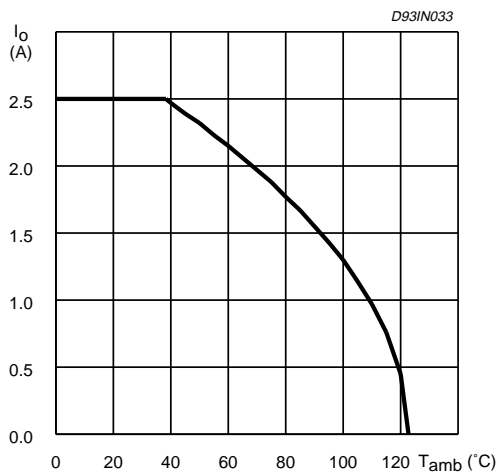
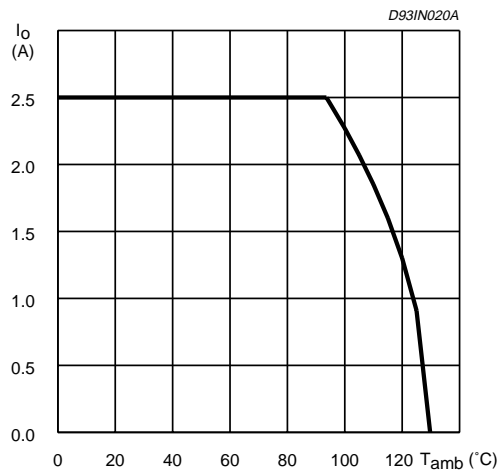
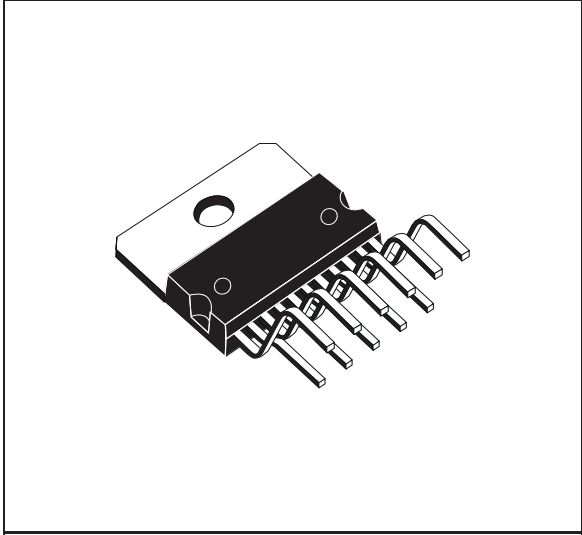

Figure 8: Max. Output Current vs. Ambient Temperature (Multiwatt with heatsink, $R_{th(j-amb)} = 15^\circ C/W$)



DIM.	mm			inch		
	MIN.	TYP.	MAX.	MIN.	TYP.	MAX.
A			5			0.197
B			2.65			0.104
C			1.6			0.063
D		1			0.039	
E	0.49		0.55	0.019		0.022
F	0.88		0.95	0.035		0.037
G	1.45	1.7	1.95	0.057	0.067	0.077
G1	16.75	17	17.25	0.659	0.669	0.679
H1	19.6			0.772		
H2			20.2			0.795
L	21.9	22.2	22.5	0.862	0.874	0.886
L1	21.7	22.1	22.5	0.854	0.87	0.886
L2	17.4		18.1	0.685		0.713
L3	17.25	17.5	17.75	0.679	0.689	0.699
L4	10.3	10.7	10.9	0.406	0.421	0.429
L7	2.65		2.9	0.104		0.114
M	4.25	4.55	4.85	0.167	0.179	0.191
M1	4.73	5.08	5.43	0.186	0.200	0.214
S	1.9		2.6	0.075		0.102
S1	1.9		2.6	0.075		0.102
Dia1	3.65		3.85	0.144		0.152

OUTLINE AND MECHANICAL DATA



Multiwatt11 V

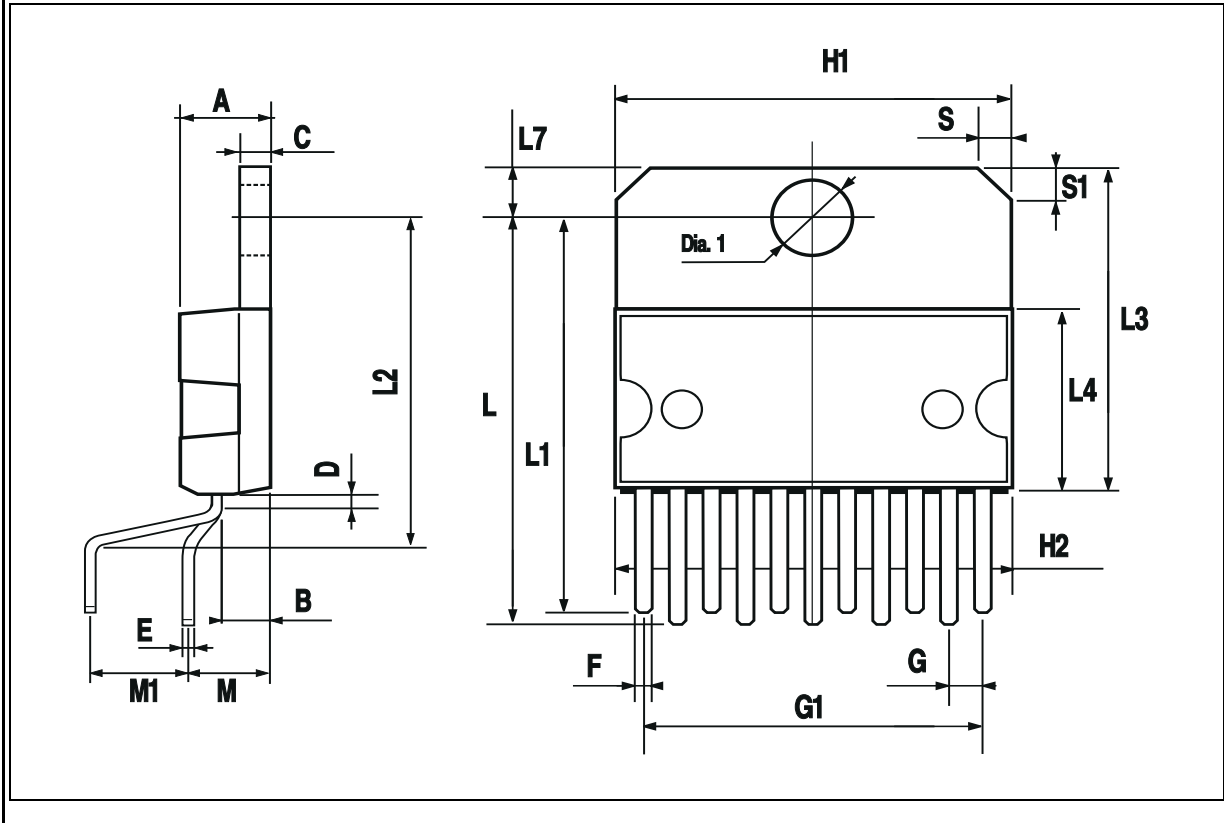

TDE1890 - TDE1891

DIM.	mm			inch		
	MIN.	TYP.	MAX.	MIN.	TYP.	MAX.
A			5			0.197
B			2.65			0.104
C			1.6			0.063
E	0.49		0.55	0.019		0.022
F	0.88		0.95	0.035		0.037
G	1.57	1.7	1.83	0.062	0.067	0.072
G1	16.87	17	17.13	0.664	0.669	0.674
H1	19.6			0.772		
H2			20.2			0.795
L	26.4		26.9	1.039		1.059
L1	22.35		22.85	0.880		0.900
L3	17.25	17.5	17.75	0.679	0.689	0.699
L4	10.3	10.7	10.9	0.406	0.421	0.429
L7	2.65		2.9	0.104		0.114
S	1.9		2.6	0.075		0.102
S1	1.9		2.6	0.075		0.102
Dia1	3.65		3.85	0.144		0.152

OUTLINE AND MECHANICAL DATA

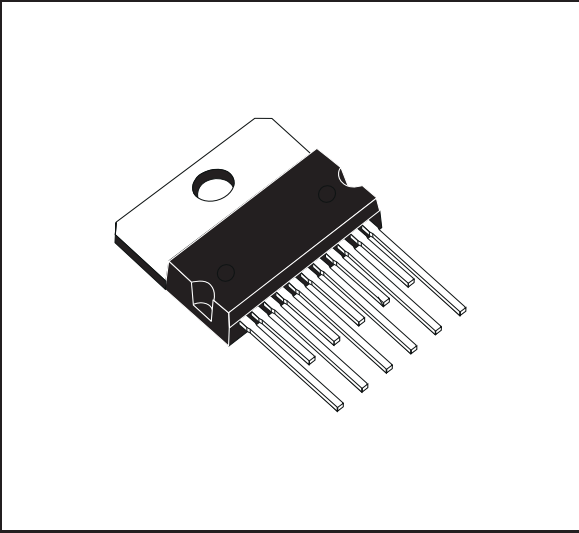

Multiwatt11 (In-Line)

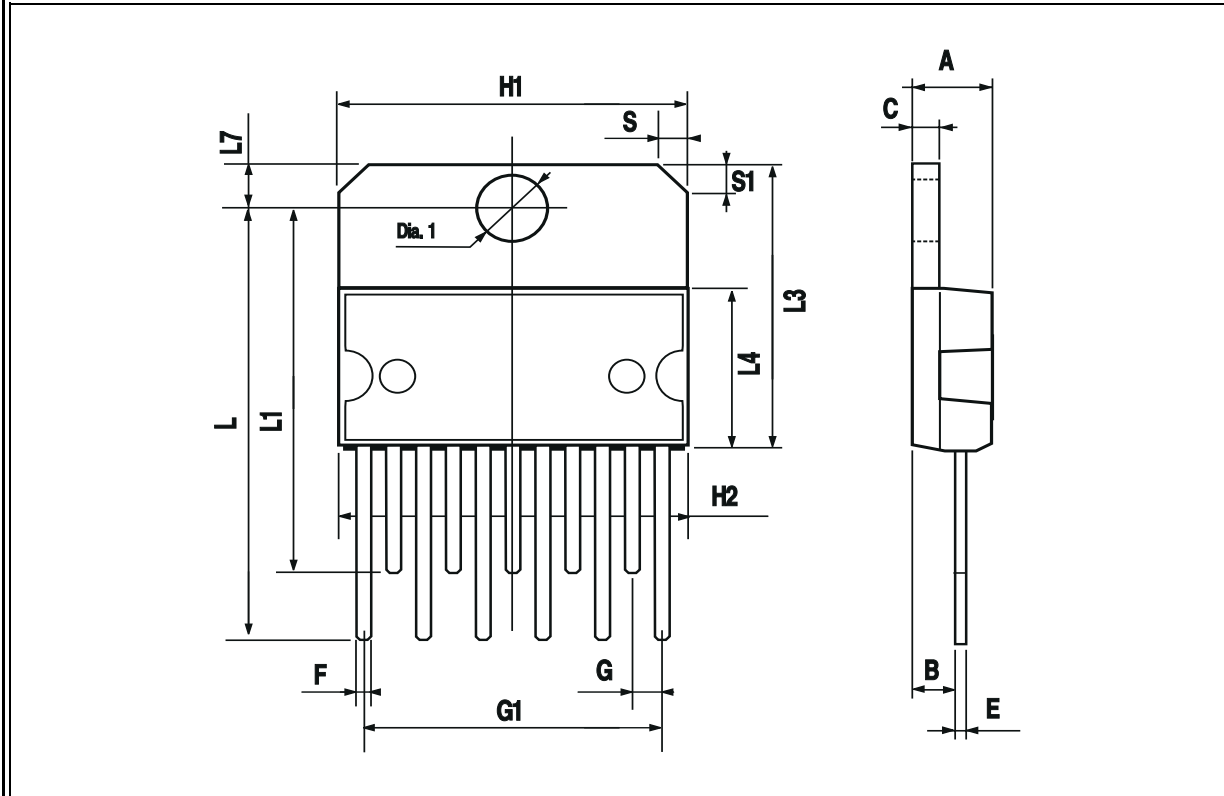

DIM.	mm			inch		
	MIN.	TYP.	MAX.	MIN.	TYP.	MAX.
A			3.6			0.142
a1	0.1		0.3	0.004		0.012
a2			3.3			0.130
a3	0		0.1	0.000		0.004
b	0.4		0.53	0.016		0.021
c	0.23		0.32	0.009		0.013
D (1)	15.8		16	0.622		0.630
D1	9.4		9.8	0.370		0.386
E	13.9		14.5	0.547		0.570
e		1.27			0.050	
e3		11.43			0.450	
E1 (1)	10.9		11.1	0.429		0.437
E2			2.9			0.114
E3	5.8		6.2	0.228		0.244
G	0		0.1	0.000		0.004
H	15.5		15.9	0.610		0.626
h			1.1			0.043
L	0.8		1.1	0.031		0.043
N	8° (typ.)					
S	8° (max.)					
T		10			0.394	

(1) "D and E1" do not include mold flash or protusions.
 - Mold flash or protusions shall not exceed 0.15mm (0.006")
 - Critical dimensions: "E", "G" and "a3".

OUTLINE AND MECHANICAL DATA

Weight: 1.9gr

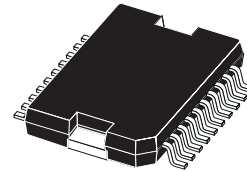

JEDEC MO-166

PowerSO20

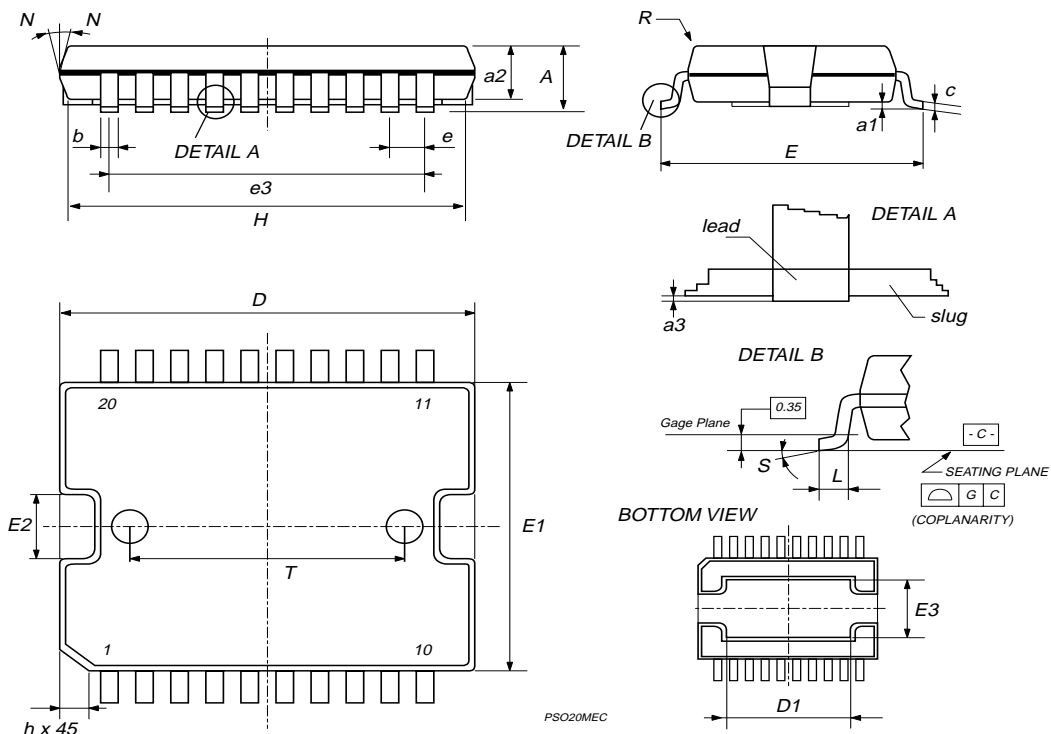

Information furnished is believed to be accurate and reliable. However, STMicroelectronics assumes no responsibility for the consequences of use of such information nor for any infringement of patents or other rights of third parties which may result from its use. No license is granted by implication or otherwise under any patent or patent rights of STMicroelectronics. Specifications mentioned in this publication are subject to change without notice. This publication supersedes and replaces all information previously supplied. STMicroelectronics products are not authorized for use as critical components in life support devices or systems without express written approval of STMicroelectronics.

The ST logo is a registered trademark of STMicroelectronics.
All other names are the property of their respective owners

© 2003 STMicroelectronics - All rights reserved

STMicroelectronics GROUP OF COMPANIES

Australia – Belgium - Brazil - Canada - China – Czech Republic - Finland - France - Germany - Hong Kong - India - Israel - Italy - Japan -
Malaysia - Malta - Morocco - Singapore - Spain - Sweden - Switzerland - United Kingdom - United States

www.st.com