



## VB027BSP

# HIGH VOLTAGE IGNITION COIL DRIVER POWER I.C.

TYPE	V <sub>cl</sub>	I <sub>cl</sub>	I <sub>d(on)</sub>
VB027BSP	320V	10.5A	160mA

- PRIMARY COIL VOLTAGE INTERNALLY SET
- COIL CURRENT LIMIT INTERNALLY SET
- LOGIC LEVEL COMPATIBLE INPUT
- DRIVING CURRENT QUASI PROPORTIONAL TO COLLECTOR CURRENT
- DOUBLE FLAG-ON COIL CURRENT

### DESCRIPTION

The VB027BSP is a high voltage power integrated circuit made using the STMicroelectronics VIPower™ technology, with vertical current flow power darlington and logic level compatible driving circuit. Built-in protection circuit for coil current limiting and collector voltage clamping allows the device to be used as smart, high

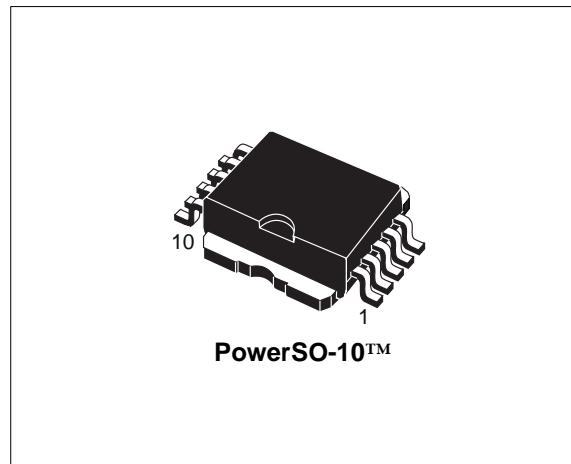

voltage, high current interface in advanced electronic ignition system.

### BLOCK DIAGRAM

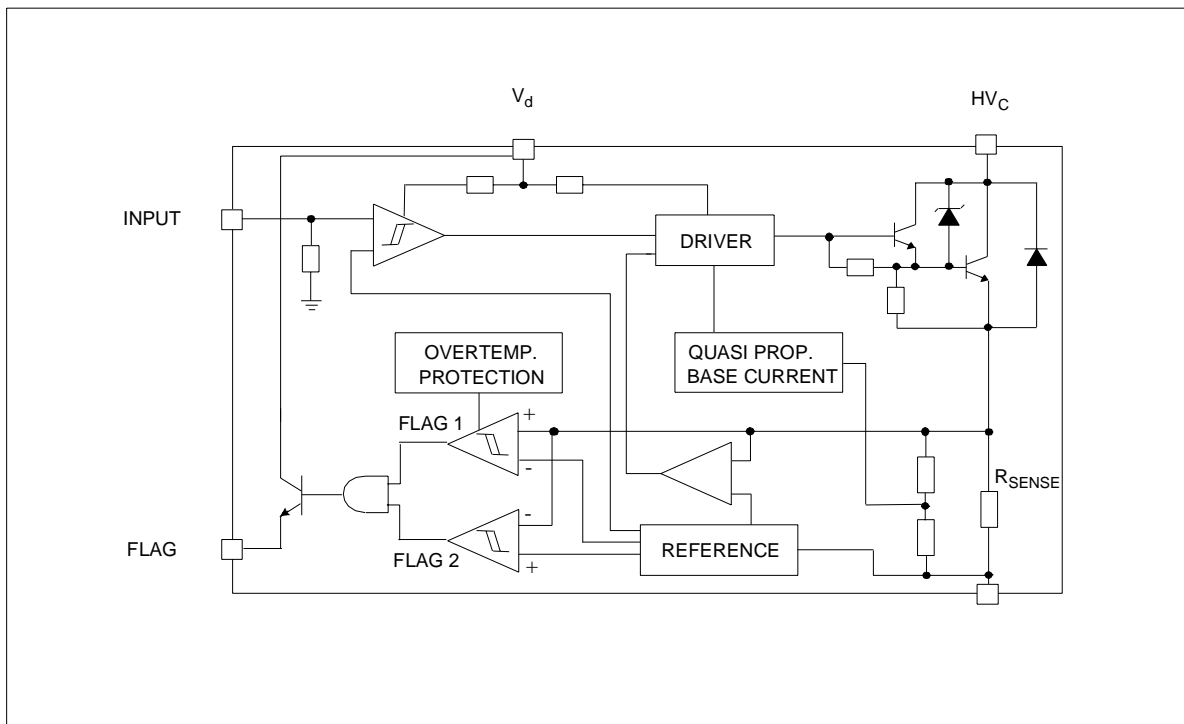

## VB027BSP

### ABSOLUTE MAXIMUM RATING

Symbol	Parameter	Value	Unit
$HV_C$	Collector voltage	Internally limited	V
$I_C$	Collector current	Internally limited	A
$V_d$	Driving stage supply voltage	7	V
$I_d$	Driving circuitry supply current	200	mA
$V_{IN}$	Input voltage	10	V
$T_j$	Junction operating temperature	-40 to 150	°C
$T_{stg}$	Storage temperature	-55 to 150	°C

### THERMAL DATA

Symbol	Parameter	Value	Unit
$R_{thj-case}$	Thermal resistance junction-case (MAX)	1.12	°C/W
$R_{thj-amb}$	Thermal resistance junction-ambient (MAX)	62.5	°C/W

### CONNECTION DIAGRAM (TOP VIEW)

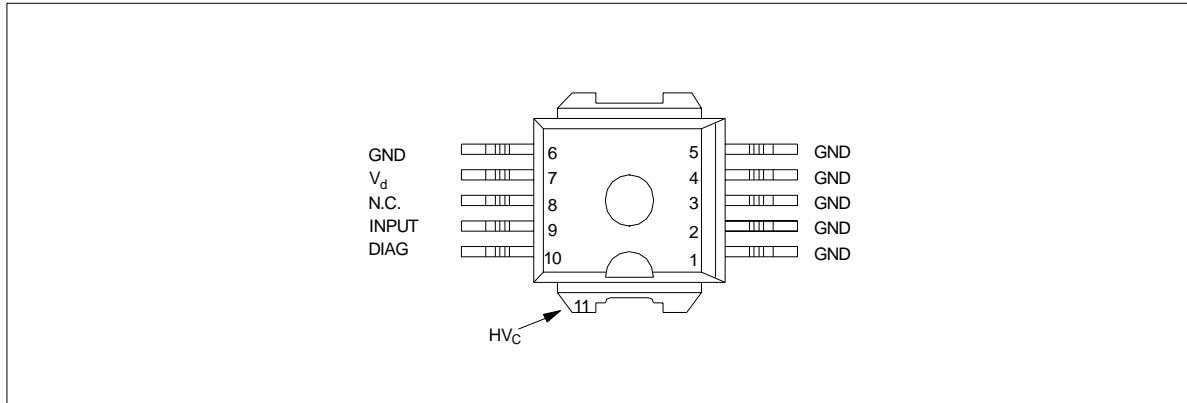

### PIN FUNCTION

No	Name	Function
1÷5	GND	Emitter power ground
6(*)	GND	Control ground
7	$V_d$	Driving stage supply voltage
8	N.C.	
9	INPUT	Logic input channel
10	DIAG	Diagnostic output signal (when $I_C$ is greater than 3A)
TAB	$HV_C$	Primary coil output signal

(\*) Pin 1÷5=Power GND, Pin 6=signal GND. Pin 6 must be connected to pins 1÷5 externally.

**ELECTRICAL CHARACTERISTICS** ( $V_{CC}=13.5V$ ;  $V_d=5V$ ;  $T_j=25^\circ C$ ;  $R_{coil}=510m\Omega$ ;  $L_{coil}=7mH$  unless otherwise specified)

Symbol	Parameter	Test Conditions	Min	Typ	Max	Unit
$V_{cl}$	High voltage clamp	$-40^\circ C \leq T_j \leq 125^\circ C$ ; $I_C=6A$	320		420	V
$V_{cg(sat)}$	Power stage saturation voltage	$I_C=6A$ ; $V_{IN}=4V$ ; $-40^\circ C \leq T_j \leq 125^\circ C$			2	V
$I_{d(off)}$	Power-off supply current	$V_{IN}=0.4V$			11	mA
$I_{d(on)}$	Power-on supply current	$V_{IN}=4V$ ; $I_C=6A$ ; $-40^\circ C \leq T_j \leq 125^\circ C$			160	mA
$V_d$	Driving stage supply voltage		4.5		5.5	V
$I_{cl}$	Collector current limit	$V_{IN}=4V$	8.5		10.5	A
$I_{cl(td)}$	Collector current limit drift with temperature	See figure 3				
$I_{leak}$	Collector leakage current	$V_c=125V$			100	$\mu A$
$V_{INH}$	High level input voltage		4		5.5	V
$V_{INL}$	Low level input voltage		0		0.8	V
$I_{INH}$	High level input current				200	$\mu A$
$V_{diagH}$	High level diagnostic output voltage	$R_{EXT}=15K\Omega$ ; $C_{EXT}=1nF$ (See figure 1)	3.5		$V_d$	V
$V_{diagL}$	Low level diagnostic output voltage	$R_{EXT}=22K\Omega$ ; $C_{EXT}=1nF$ (See figure 1)			0.5	V
$I_{C(diag1)}$	First threshold level collector current		4.25	4.5	4.75	A
$I_{C(diag1)td}$	First threshold level collector current drift with temperature	See figure 4				
$I_{C(diag2)}$	Second threshold level collector current		5.45	5.8	6.15	A
$I_{C(diag2)td}$	Second threshold level collector current drift with temperature	See figure 5				
$I_{diagH}$	Overtemperature diagnostic current		2	2.6	3.2	A
$t_{d(off)}$	Turn-off delay time of output current	$I_C=6A$	5	25	45	$\mu s$
$t_{f(off)}$	Turn-off fall time of output current	$I_C=6A$	2	8	15	$\mu s$
$E_{s/b}$	Single pulse avalanche energy		300			mJ
$T_{int}$	Temperature of diagnostic shift		130	150	170	$^\circ C$
$T_{hys}$	Thermal hysteresis			30		$^\circ C$
$V_f$	Diode forward voltage	$I_C=-10A$		3		V

# VB027BSP

## PRINCIPLE OF OPERATION

The VB027BSP is mainly intended as high voltage power switch device driven by a logic level input and interfaces directly to a high energy electronic ignition coil.

The input  $V_{IN}$  of the VB027BSP is fed from a low power signal generated by an external controller that determines both dwell time and ignition point. During  $V_{IN}$  high ( $\geq 4V$ ) the VB027BSP increases current in the coil to the desired, internally set current level.

When the collector current exceeds 4.5A, the diagnostic signal is turned high and it remains so, until the load current reaches 5.8A (second threshold). At that value, the diagnostic signal is turned low, and the  $\mu C$  forces the  $V_{IN}$  to the low state. During the coil current switch-off, the primary voltage  $HV_C$  is clamped by a series of Zener diodes at an internally set value  $V_{cl}$  typically 365V.

The collector current sensed through the  $R_{sense}$ , is limited thanks to the "Current limiter" block that, as soon as the  $I_{cl}$  level is reached, forces the darlington (using the "Driver" block) to limit the current provided.

The transition from saturation to desaturation, coil current limiting phase, must have the ability to accommodate an overvoltage. A maximum overshoot of 20V is allowed.

There can be some short period of time in which the output pin ( $HV_C$ ) is pulled below ground by a negative current due to leakage inductances and stray capacitances of the ignition coil. This can cause parasitic glitches on the diagnostic output. VB027BSP has a built-in protection circuit that allows to lock the p-buried layer potential of the linear stage of the collector power, when the last one is pulled underground.

## THERMAL BEHAVIOUR

You can see in the block diagram of the VB027BSP a box called overtemperature protection. The purpose of this circuit is to shift the current level at which the first diagnostic is activated down to about 2.5A.

This information can be managed by the micro that can take the corrective action in order to reduce the power dissipation. This block is not an effective protection but just an overtemperature detection. The shift down of the first flag level cannot be present for temperatures lower than 125°C.

As an example of its behavior you can suppose a very simple motor management system in which the micro does just a simple arithmetic calculation to decide when to switch-off the device after the first flag threshold.

### EXAMPLE:

$I_{C(DIAG1)}$  info after x ms ( $I_{C(DIAG1)}=4.5A$ )

$I_{switch-off}$  info after kx ms.

As soon as the temperature rises over the overtemp threshold, the first diagnostic is shifted down to about 2.5A and, in this example, the switch-off current will be  $kx \cdot 2.5 / 4.5$ .

### OVERVOLTAGE

The VB027BSP can withstand the following transients of the battery line:

-100V / 2ms ( $R_i=10\Omega$ )

+100V / 0.2ms ( $R_i=10\Omega$ )

+50V / 400ms ( $R_i=4.2\Omega$ , with  $V_{IN}=3V$ )

FIGURE 1: Application circuit

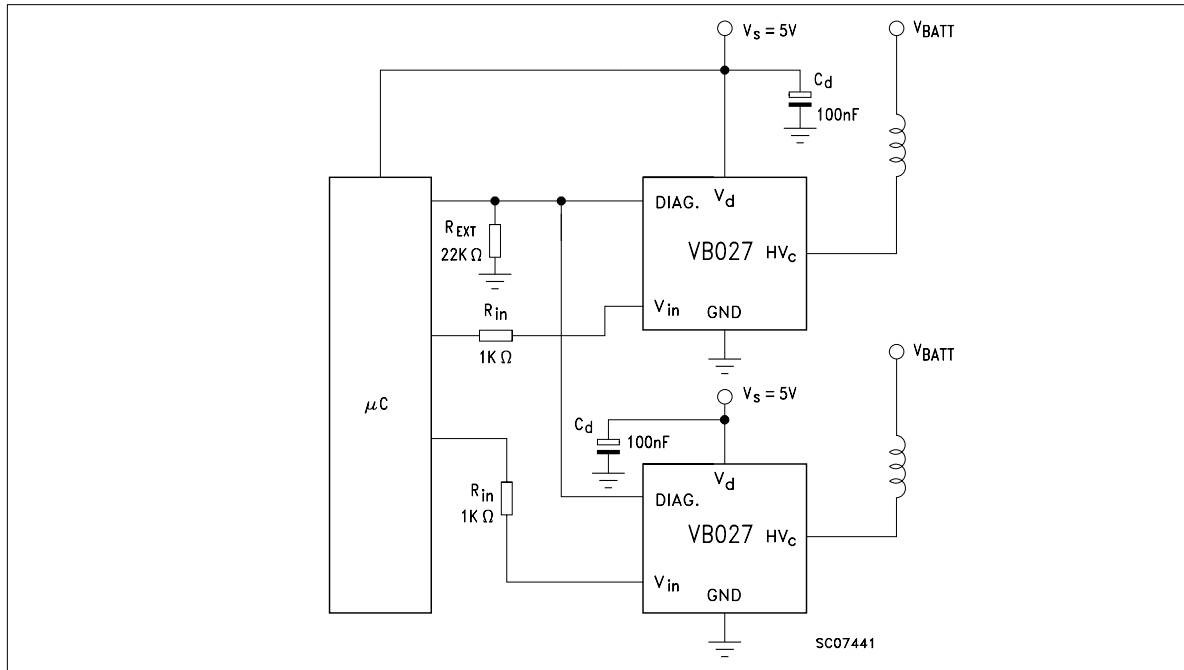

FIGURE 2: Switching waveform

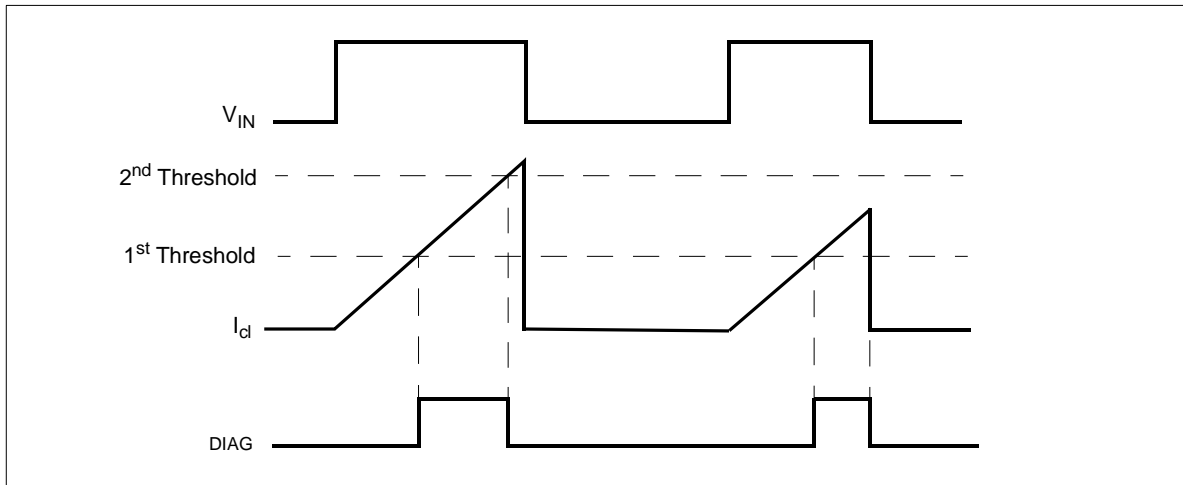

FIGURE 3: Maximum  $I_{cl}$  VS temperature

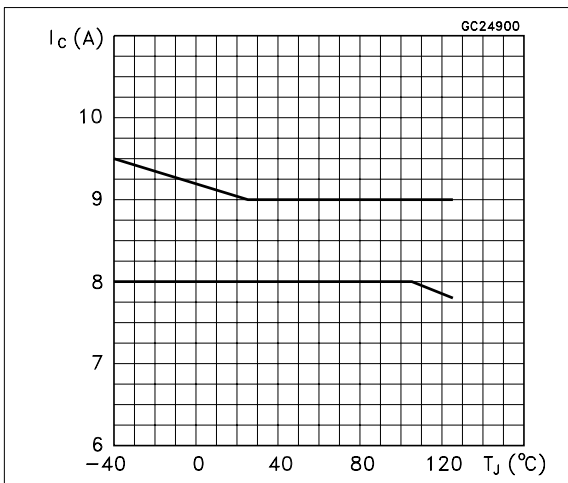

FIGURE 5:  $I_{C(diag2)}$  VS temperature

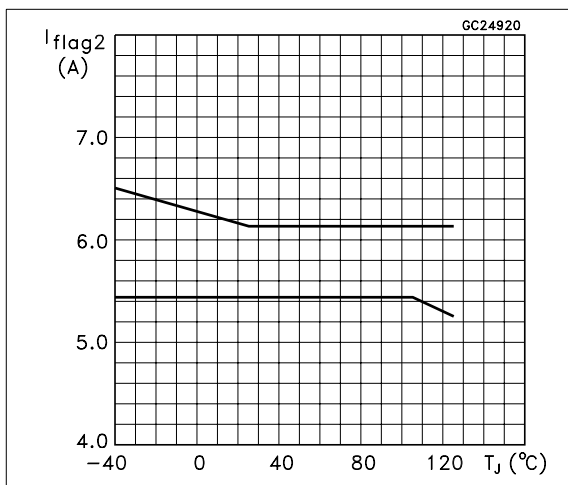

FIGURE 4:  $I_{C(diag1)}$  VS temperature

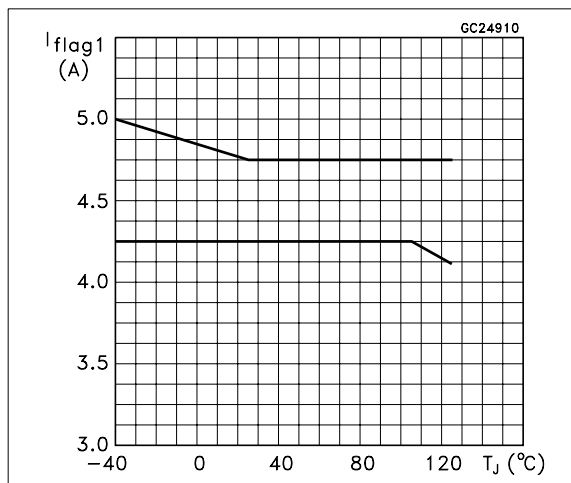
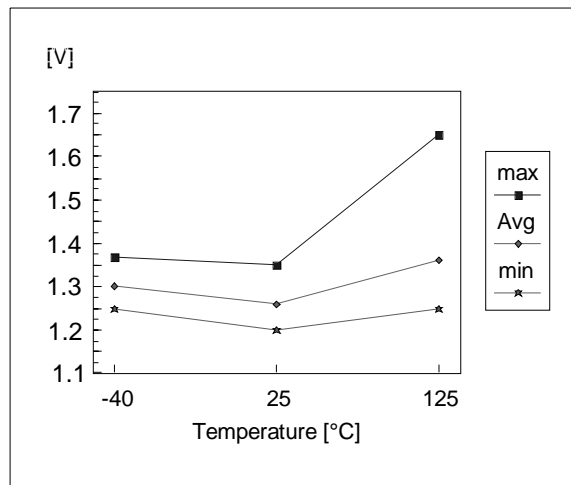
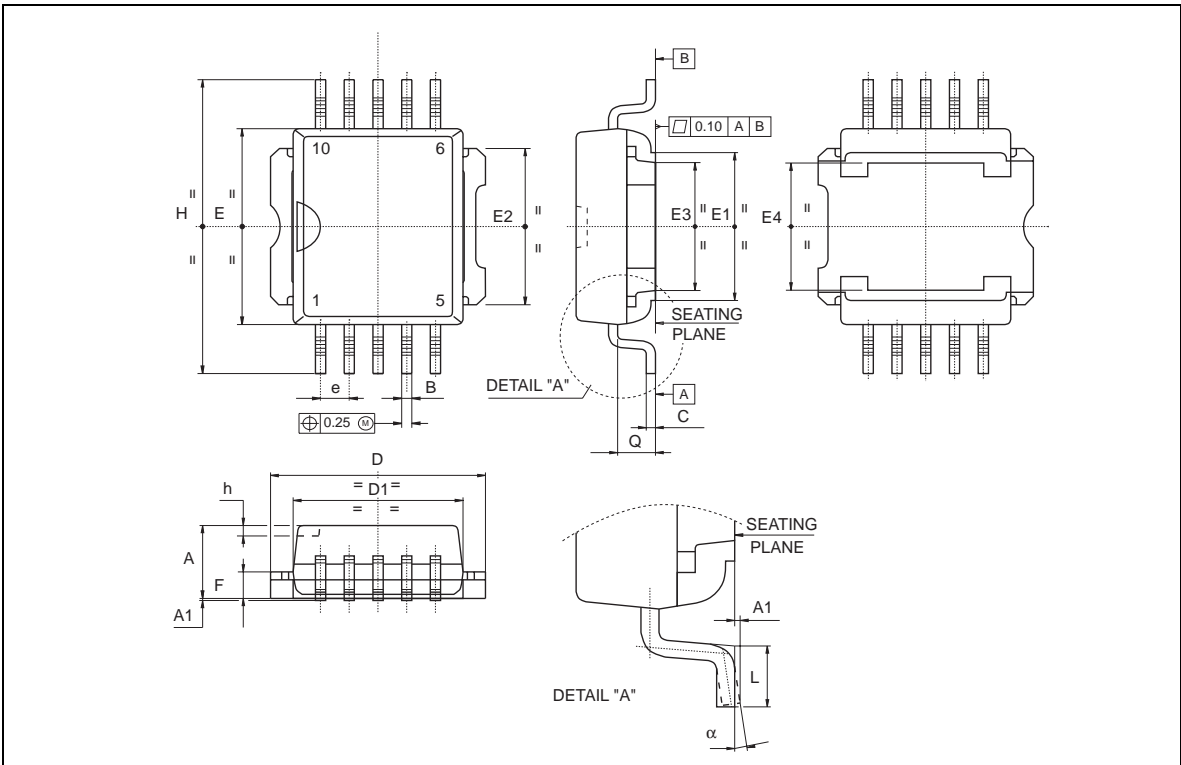

FIGURE 6:  $V_{cg(sat)}$  VS temperature (at  $I_C=6A$ )



**PowerSO-10™ MECHANICAL DATA**

DIM.	mm.			inch		
	MIN.	TYP	MAX.	MIN.	TYP.	MAX.
A	3.35		3.65	0.132		0.144
A1	0.00		0.10	0.000		0.004
B	0.40		0.60	0.016		0.024
c	0.35		0.55	0.013		0.022
D	9.40		9.60	0.370		0.378
D1	7.40		7.60	0.291		0.300
E	9.30		9.50	0.366		0.374
E1	7.20		7.40	0.283		0.291
E2	7.20		7.60	0.283		300
E3	6.10		6.35	0.240		0.250
E4	5.90		6.10	0.232		0.240
e		1.27			0.050	
F	1.25		1.35	0.049		0.053
H	13.80		14.40	0.543		0.567
h		0.50			0.002	
Q		1.70			0.067	
$\alpha$	0°		8°			



Information furnished is believed to be accurate and reliable. However, STMicroelectronics assumes no responsibility for the consequences of use of such information nor for any infringement of patents or other rights of third parties which may result from its use. No license is granted by implication or otherwise under any patent or patent rights of STMicroelectronics. Specifications mentioned in this publication are subject to change without notice. This publication supersedes and replaces all information previously supplied. STMicroelectronics products are not authorized for use as critical components in life support devices or systems without express written approval of STMicroelectronics.

The ST logo is a registered trademark of STMicroelectronics

© 1998 STMicroelectronics - Printed in ITALY- All Rights Reserved.

STMicroelectronics GROUP OF COMPANIES

Australia - Brazil - Canada - China - France - Germany - Italy - Japan - Korea - Malaysia - Malta - Mexico - Morocco -  
The Netherlands- Singapore - Spain - Sweden - Switzerland - Taiwan - Thailand - United Kingdom - U.S.A.