

6-BIT MAGNETIC ANGULAR POSITION ENCODER WITH SERIAL INTERFACE

Key Features

- ❑ Up to 64 positions within 360°
- ❑ Non contact switching
- ❑ Simple magnet as rotary encoder
- ❑ Zero position programmable (independent of magnet orientation)
- ❑ Synchronous Serial Interface (SSI)
- ❑ Cascading is possible
- ❑ Chip Select Input
- ❑ Small 8-Pin SOIC (SMT) Package
- ❑ Temperature Range: -40°C ...+85°C

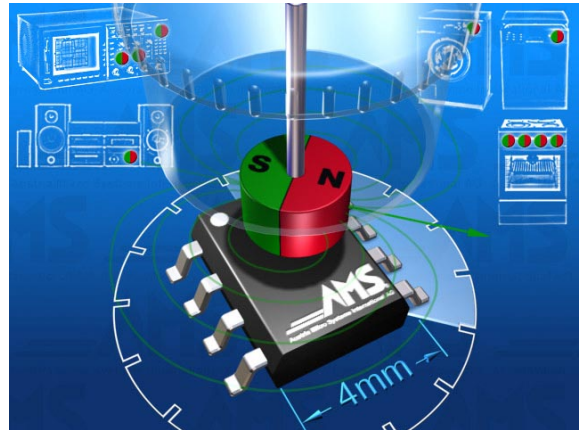

Ordering Information

Part Number	Package
AS5020	SOIC 8
AS5020T	SOIC8 Tape and Reel

General Description

The device provides the absolute angular position of a simple magnet that is placed under or above the device's surface. The device includes the Hall Sensor Array, signal conditioning and post processing needed to generate a 6-bit binary code. The binary code can be easily accessed by a Synchronous Serial Interface (SSI). The angle between the device and the magnetic polarisation axis is exactly represented by one of 64 sectors (of 5.625° each) in the full 360° range. Zero-Position Programming allows one time programming of a specific zero position between the device and the magnet. The initial zero position is shown below.

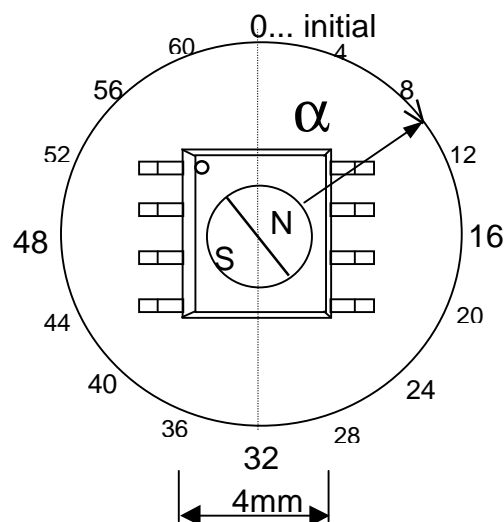
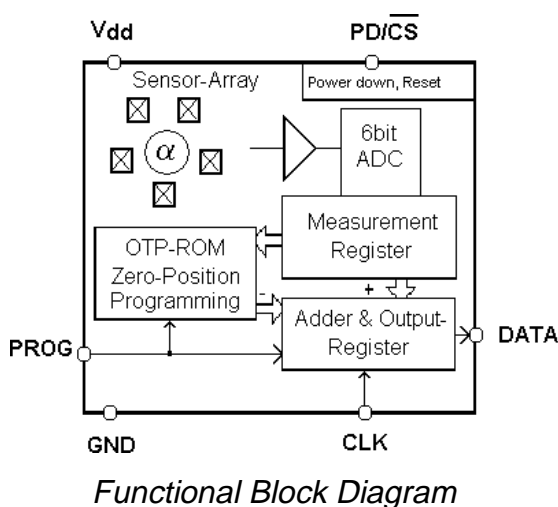

Pin Description

Pin #	Symbol	Type	Description
1	DATA	DO	DATA Output of the SSI. If $\overline{\text{PD/CS}}=0$, the measured angle data (6bit value) is serially shifted out over this pin by the CLK, starting with the MSB. A NVR Bit and a Parity bit are added. (NVR=1 indicates a Non-Valid Range of the magnetic field.) Even Parity is given.
2	V_{DD}	AI	Positive Supply Voltage.
3	V_{SS}	AI	Negative Supply Voltage (GND).
4	PROG	DI	PROG ramming Input. This pin is used to program the zero position into a non-volatile memory (OTP). The programmed value is subtracted from the actual measured angle.
5	N.C.	AI	Not Connected during operation. This pin is used for testing purposes.
6	N.C.	AI	Not Connected during operation. This pin is used for testing purposes.
7	$\overline{\text{PD/CS}}$	DI	Power Down Input, Disable or Chip Select (active low). $\overline{\text{PD/CS}}=0$ activates the device and enables the measurement. $\overline{\text{PD/CS}}=1$ sets the device in power save mode and puts the DATA pin in high impedance (highZ) state.
8	CLK	DI	CLOCK Input of the SSI. This pin is used to serially clock out the measured angle data at Pin 7 (DATA).

DI: Digital Input

DO: Digital Output

MSB: Most Significant Bit

LSB: Least Significant Bit

Note: The pins 5 and 6 must not be connected!

AI: Analogue Input

OTP: One Time Programmable

Pin Configuration

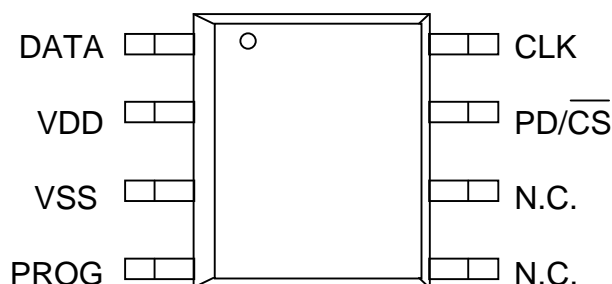

Functional Description

Measurement Principle

A hall sensor array is used to convert the magnetic field distribution above the chip surface into a binary code.

Measurement is enabled by $\overline{PD/\overline{CS}}=0$. After each measurement a 6-bit value is latched, with the first falling edge of the CLK, into an output shift register.

The measured data is accessible via a Synchronous Serial Interface (SSI) by any μ Controller System.

Ratiometric measurement techniques together with hall sensor conditioning circuitry allow robust tolerance to magnet misalignment.

Permanent Encoder Magnet

A simple two-pole magnet, e.g. a standard cylindrical permanent magnet that is diametric magnetised, is needed.

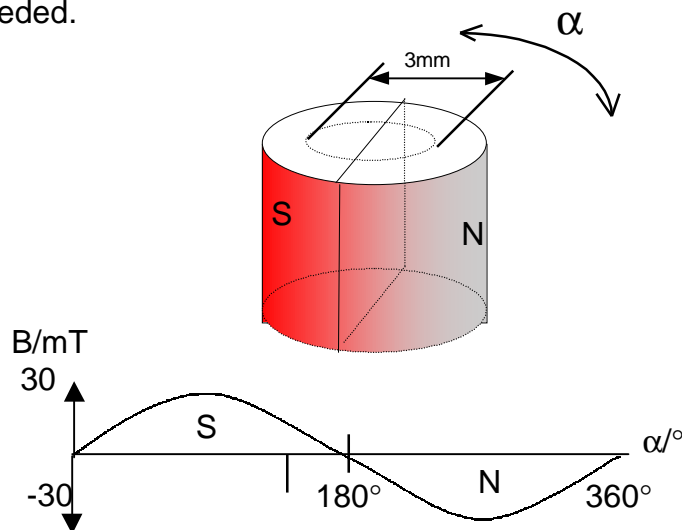

Magnetic Field strength of at least $\pm 30mT$ is required at the package surface.

Standard magnet materials like rare earth AlNiCo / SmCo5 or NdFeB are recommended. Please enquire for distributor references.

Measurement Modes

Two measurement modes can be selected by programming:

- 1) Single Read Out Mode (default)
- 2) Continuous Read Out Mode (OTP option)

Chip Select must be active low ($\overline{PD/CS}=0$) to enable measurement and bring the output DATA out of high impedance state.

After a minimum measurement period, the first falling edge of CLK latches the actual measured angular value. The following rising edges shift the data bits out of the DATA pin, beginning with the most significant bit. An NVR bit and even parity bit are added to the 6 bit angular value. The NVR bit indicates a non-valid range given by bad magnet positioning.

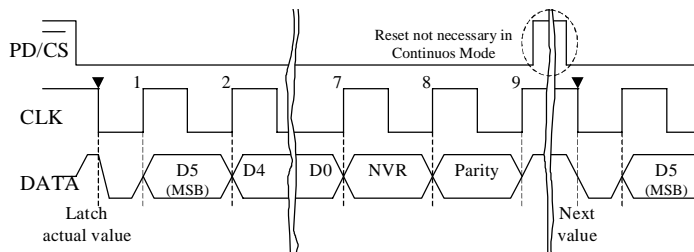

Figure 1 SSI read out

In Single Read Out Mode the start of a new measurement has to be initiated with a short pulse at $\overline{PD/CS}$ of at least 1 clockcycle. The following falling edge of CLK latches a new measured value.

If the OTP option Continuous Read Out Mode is chosen, repeated angle measurement is enabled by $\overline{PD/CS}=0$. After each read out sequence the output shift register is automatically refreshed. Fast transmission of the angular data can be performed without pulsing $\overline{PD/CS}$.

Daisy Chain Configuration

In Single Read Out mode, cascading allows Daisy Chain structures to minimise the interconnection lines. Connecting DATA with PROG of the cascaded Sensor (see Fig. 2) allows the read out of n sensors with the use of only three wires. The measurement data is shifted in this configuration through the devices

After $n \times 9$ clock cycles each value of n sensors is visible at pin DATA of the first sensor device. A new measurement can be started with the falling edge of CLK after a power down pulse at $\overline{PD/CS}$.

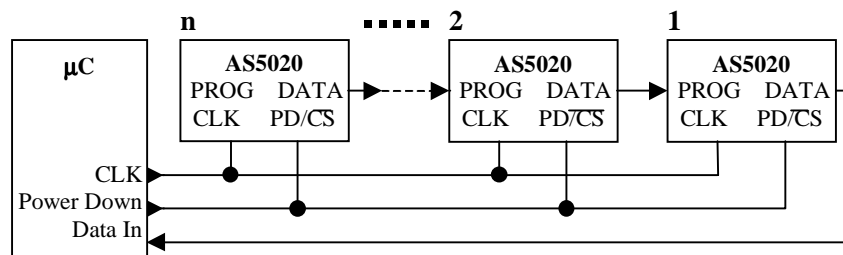

Figure 2 Typical Daisy Chain Configuration

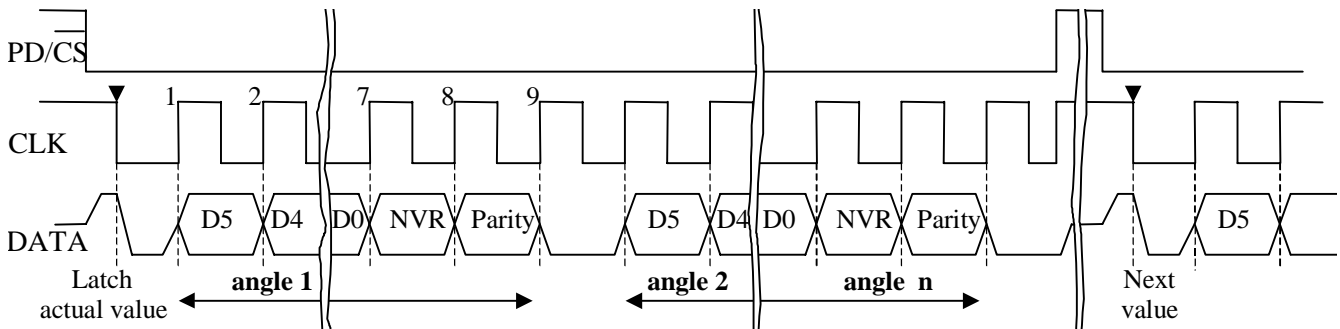

Figure 3 Daisy Chain read out

Zero Position Programming

A simple single pin programming allows changing the initial zero position. It is easy to program permanently a new zero-reference into the internal OTP (one time programmable) ROM. This allows a fast and economic magnet placement since the intrinsic orientation is not important.

Single Pin Programming is provided via the PROG pin. Fig.4 shows the typical programming sequence needed for fixing the new zero position.

Zero Position Programming Sequence

Before calibration, the $\overline{\text{new}}$ zero position must be adjusted in measurement mode ($\overline{\text{PD/CS}}=0$). The rising edge of $\overline{\text{PD/CS}}$ gets the actual position and stores it internally for the permanent programming. A high level at the PROG Pin during power-down ($\overline{\text{PD/CS}}=1$) with a minimum duration of $300\mu\text{s}$ enables programming. After one initial dummy bit pulse, six pulses of $8V/5\mu\text{s}$ select the latched position information and zap the reference value into the OTP ROM.

Continuous Read Out Mode Selection

An optional 9th pulse after the initialisation pulse, the dummy pulse, and the 6 data pulses can be used to set Continuous Read Out Mode (see Fig.4).

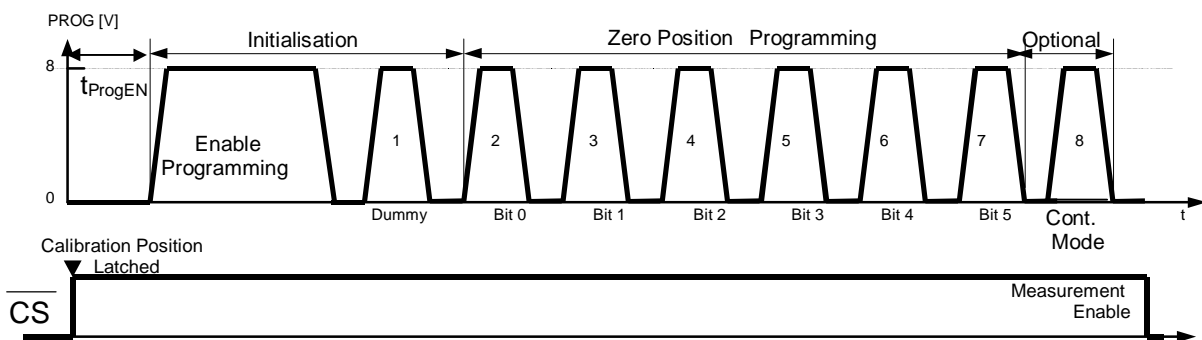

Figure 4 Programming sequence

Note: Daisy Chain configuration is not possible in Continuous Read Out Mode.

Electrical Characteristics

Absolute Maximum Ratings*

Supply Voltage	$-0.3 \leq V_{DD} \leq 7V$
Input Current	25 mA
Digital Input Voltage	$-0.3V \leq V_{IN} \leq V_{DD} + 0.3V$
Electrostatic Discharge	+/- 1000V
Storage Temperature Range.....	-50 to +125°C
Total Power Dissipation	150mW

*Stresses beyond those listed under “Absolute Maximum Ratings” may cause permanent damage to the device. These are stress ratings only. Functional operation of the device at these or any other conditions beyond those indicated under “Operating Conditions” is not implied. Exposure to absolute maximum rating conditions for extended periods may affect device reliability.

Operating Conditions

Symbol	Parameter	Conditions	Min.	Typ.*	Max.	Unit
V_{DD}	Supply Voltage	Measurement mode, $V_{SS} = 0 V$	4.5	5.0	5.5	V
T_{AMB}	Ambient Operating Temp. Range		-40	25	+85	°C
V_{IL}	Input Low Voltage		V_{SS}		$0.3 V_{DD}$	V
V_{IH}	Input High Voltage**		$0.7 V_{DD}$		V_{DD}	V

* Typical figures are at 25°C and are for design aid only; not guaranteed and not subject to production testing.
Note: External Buffer-Capacitance is needed: e.g. 4.7uF between the Supply-Pins.

** Note: At pin PROG a higher voltage (up to 8.5V) as defined for the zero position programming routine.

Programming Input *see Figure 4*

Symbol	Parameter	Conditions	Min.	Typ.	Max.	Units
V_{PROG}	Programming Voltage		8		8.5	V
t_{ZAP}	Zap pulse duration		4.5	5	5.5	µs
t_{ProgEN}	Delay after $\overline{CS}=1$		200			µs
t_{LH}	Pulse slew rate		2			V/µs

DC Characteristics

Symbol	Parameter	Conditions	Min.	Typ.	Max.	Units
I_{DD}	Operating Supply Current	Continuous Read Out Mode*	15		24	mA
I_{DD0}	Power Down Current	$PD/\overline{CS}=1$	0.5		1	mA
I_{OL}	Output Current, Sink	$V_{OL} = 0.4V$		1		mA

- Note: I_{DD} in Single Read Out Mode is the same during the measurement phase

Timing Characteristics

Symbol	Parameter	Conditions	Min.	Typ.	Max.	Unit
t_{SetUp}	Set up time after power on		20			μs
t_{Reset}	Minimum reset duration		1			μs
t_{meas}	Min. waiting time for a single measurement *		20			μs
$t_{clkDATA}$	Max. CLK-DATA valid delay				10	ns
t_{latch}	Min. Hold time after latching		5			μs
T_{CLK}	Data shift clock periode		1			us

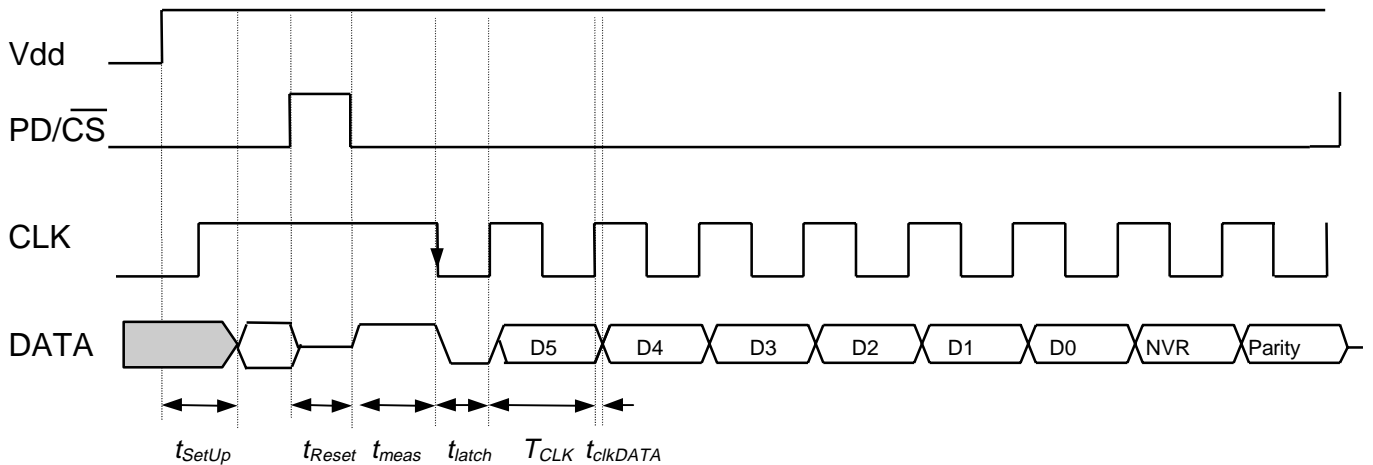

Figure 5 Timing Characteristics Single Read Out Mode

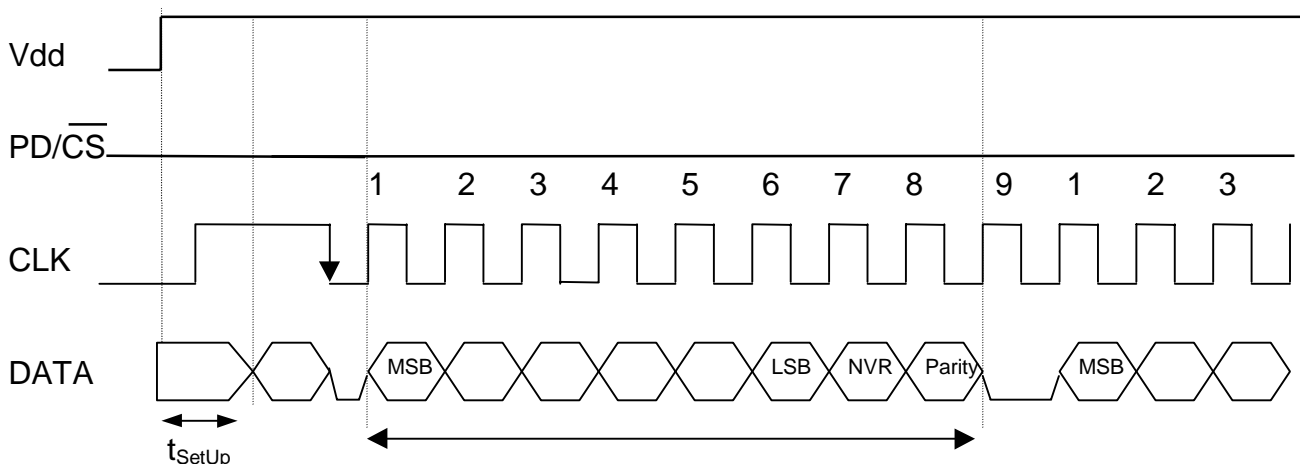

Figure 6 Timing Characteristics Continuous Read Out Mode

*Note: Multiple latching of 1 measured value in Continuous Read Out Mode is possible due to internal anti-collision of the Value Update.

Magnetic Input Characteristics*

Symbol	Parameter	Conditions	Min.	Typ.	Max.	Units
$B_{\text{min-max}}$	Processing magnetic field strength input range	At package surface	30	40	50	mT
Off_{mag}	Magnetic Offset				5	mT
$\text{DistF}_{\text{mag}}$	Magnetic distortion factor	Sinusoidal magnetic field density along 3mm concentric circle.		2	3	%
T_d	Magnet Temperature drift			-0.035		%/K
D	Diameter of encoder magnet		3	6		mm
f	Input frequency	Both directions			30000	rpm

*Note: Please ask for our preferred Magnet Supplier List.

Output Characteristics

Symbol	Parameter	Conditions	Min.	Typ.	Max.	Units
RES	Resolution			6		bits
LSB	Minimum step			5.625		deg
INL	Integral Non-Linearity	See Note 1)			0.5	LSB
DNL	Differential Non-Linearity				0.5	LSB
			No missing codes guaranteed			
TN	Transition-Noise			0.1		LSB

1) Linearity is defined in terms of end point fit and guaranteed by design, proved by simulated test signals

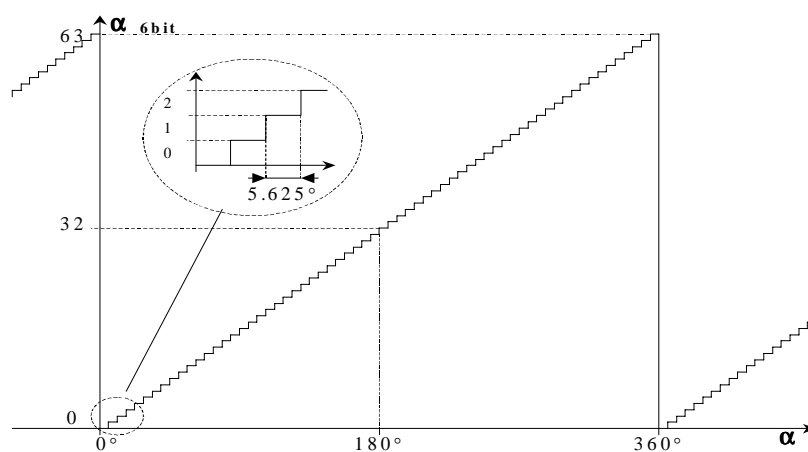
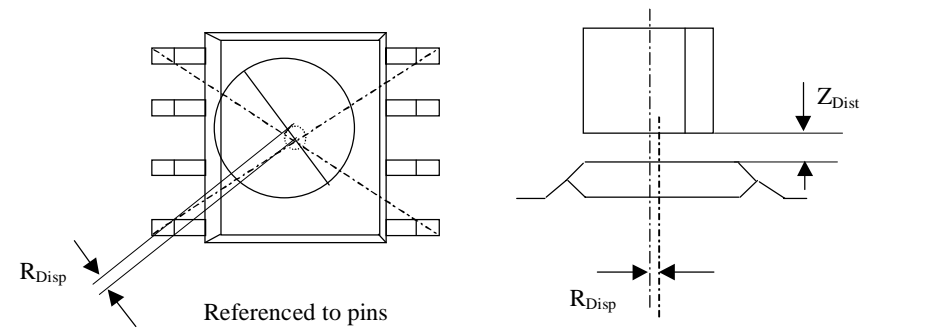

Figure 5 Output value versus input angle

Magnet Placement

Symbol	Parameter	Conditions	Min.	Typ.	Max.	Units
R_{Disp}	Displacement radius of rotational axis with reference to pins	Magnet centered on rotational axis			250	μm
Z_{Dist}	Distance between permanent magnet and package surface	With reference magnet (depends on used magnet;)		1		mm



Typical Application Areas

Non Contact Rotary Switch:

- 4, 8,16,32 Position Rotary Switch
- n of 64 Position Rotary Switch
- Digital Potentiometer, Dimmer
- Angular Encoding

- Position Control
- Isolated Switching
- Rotation Detection
- and many more

Advantages:

- No switch contacts
- Long mechanical life time
- Digital output

Similar to Daisy Chain configuration multiple devices can be connected over a serial bus structure. In this configuration the PROG pins can be connected together and allows simultaneous calibration.

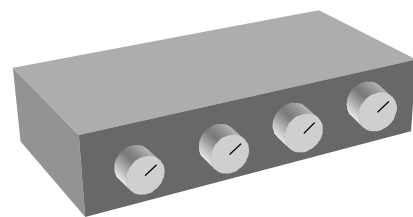

Figure 6 Front Panel Control

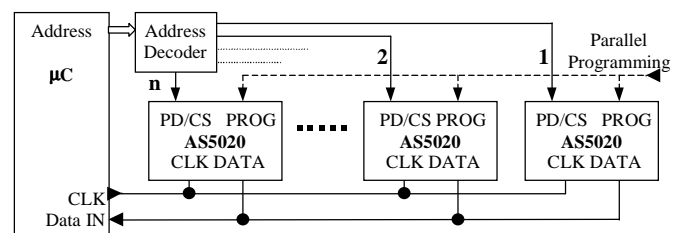

Figure 7 Serial Bus Structure

For your interest:

A demonstration board for the AS5020 is available. The board includes the AS5020, an encoder magnet, Micro-Controller and LED Display to indicate the position. Please ask your local sales office. Further information can be found at our web-page:

<http://www.amsint.com/products/product/index.html>

Headquarters:

**Austria Mikro Systeme
International AG**
Schloß Premstätten
A-8141 Unterpremstätten, Austria
Tel: +43 (3136) 500-0
Fax: +43 (3136) 525 01, 536 50
email: info@amsint.com
http: www.amsint.com

Sales Offices:

Germany:

Tegernseer Landstrasse 85
D-81539 München
Tel.: +49 (89) 69 36 43-0
Fax: +49 (89) 69 36 43-66

Wilhelm-Busch-Platz 1
D-22850 Hamburg/Norderstedt
Tel.: +49 (40) 522 80 13
Fax: +49 (40) 522 80 99

Amselweg 8
D-72820 Sonnenbühl
Tel.: +49 (7128) 92 71 28
Fax: +49 (7128) 92 71 40

France:

124 Avenue de Paris
F-94300 Vincennes
Tel.: +33 (1) 43 74 00 90
Fax: +33 (1) 43 74 20 98

United Kingdom:

Coliseum Business Centre
Watchmoor Park
Camberley, Surrey
England GU15 3YL
Tel.: +44 (1276) 23 3 99
Fax: +44 (1276) 29 3 53

USA:

Suite 300
4030 Wake Forest Road
Raleigh
NC27609
Tel.: +1 (919) 349 7551
Fax: +1 (509) 696 2713

Sweden:

Sjöängsvägen 7
S-19272 Sollentuna
Stockholm, Sweden
Tel.: +46 (8) 754 93 95
Fax: +46 (8) 754 45

Italy:

Via Leone Tolstoi, 64
I-20146 Milano
Tel.: +39 02 423 67 13
Fax: +39 02 422 90 889

Japan:

Shin Yokohama Daini Center Bldg. 10F
3-19-5, Shin Yokohama
Kohoku-ku, Yokohama 222-0033
Tel.: +81 (45) 474 0962
Fax: +81 (45) 472 9845

Devices sold by Austria Mikro Systeme are covered by the warranty and patent indemnification provisions appearing in its Term of Sale. Austria Mikro Systeme makes no warranty, express, statutory, implied, or by description regarding the information set forth herein or regarding the freedom of the described devices from patent infringement. Austria Mikro Systeme reserves the right to change specifications and prices at any time and without notice. Therefore, prior to designing this product into a system, it is necessary to check with Austria Mikro Systeme for current information. This product is intended for use in normal commercial applications. Applications requiring extended temperature range, unusual environmental requirements, or high reliability applications, such as military, medical life-support or life-sustaining equipment are specifically not recommended without additional processing by Austria Mikro Systeme for each application

Copyright © 2001, Austria Mikro Systeme International AG, Schloss Premstätten, 8141 Unterpremstätten, Austria. Trademarks Registered ®. All rights reserved. The material herein may not be reproduced, adapted, merged, translated, stored, or used without the prior written consent of the copyright owner. The information furnished here by Austria Mikro Systeme is believed to be correct and accurate. However, Austria Mikro Systeme shall not be liable to recipient or any third party for any damages, including but not limited to personal injury, property damage, loss of profits, loss of use, interruption of business or indirect, special, incidental or consequential damages, of any kind, in connection with or arising out of the furnishing, performance or use of the technical data herein. No obligation or liability to recipient or any third party shall arise or flow out of Austria Mikro Systeme rendering of technical or other services.