



Bay Linear

Inspire the Linear Power

3-Terminal 1.5Amp Adjustable Voltage Regulator

LM317

Description

The Bay Linear LM317 are monolithic integrated circuit in TO-220, TO-252, SOT-223 and D2PAK packages intended for use as positive adjustable voltage regulators.

They are designed to supply more than 1.5A of load current with an output voltage adjustable over a 1.2 to 37V range.

The nominal output voltage is selected by means of only a resistive divider, making the device exceptionally easy to use and eliminating the stocking of many fixed regulators.

Features

- **Output Current of 1.5A**
- **Output Voltage Tolerance of 5%**
- **Adjustable Output 1.2V to 37V**
- **0.1% Load & Line Regulation**
- **Internal Short-Circuit Limited**
- **Current Limit**
- **Offer in plastic TO-252, TO-220, SOT-223 & TO-263**
- **Direct Replacement for LM317**

Applications

- **Post regulator for switching DC/DC converter**
- **Bias supply for analog circuits**

Packaging Information



TO-263-3 (S)

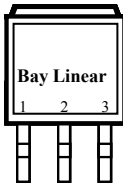

Top View

1. ADJ
2. Output
3. Input

Ordering Information

Device	Package Type	Output
LM317T	TO-220	1.5 Amp
LM317N	SOT-223	1.0 Amp
LM317S	TO-263	1.5 Amp
LM317D	TO-252	1.5 Amp

SOT-223 Vs. TO-252 Package

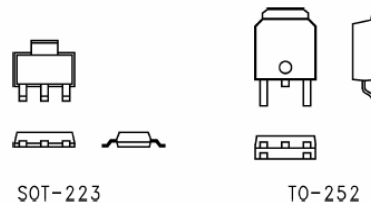

Absolute Maximum Rating

Parameter	LM317	Unit
Power Dissipation	Internally Limited	
Input Voltage Differential	+40V, -0.3V	V
Operating Free-Air, Case, Virtual Junction Temp.	0 to 150	°C
Storage Temperature Range	-65 to 150	
Lead temperature 1.6 mm from case for sec.	260	

Electrical Characteristics (LM317)

Specifications with standard type face are for $T_J = 25^\circ\text{C}$, and those with **boldface type** apply over **full Operating Temperature Range**. Unless otherwise specified, $V_{IN} - V_{OUT} = 5\text{V}$, and $I_{OUT} = 10\text{mA}$.

Parameter	Symbol	Conditions	MIN	TYP	MAX	UNIT
Reference Voltage	V_O	$3\text{V} \leq (V_{IN} - V_{OUT}) \leq 40\text{V}$ $10\text{mA} \leq I_{OUT} \leq I_{MAX}$, $P \leq P_{MAX}$	1.20	1.25	1.30	V
Line Regulation	ΔV_O	$3\text{V} \leq (V_{IN} - V_{OUT}) \leq 40\text{V}$ (Note 4)		0.01 0.02	0.02 0.05	%/V
Load Regulation	ΔV_O	$10\text{mA} \leq I_{OUT} \leq I_{MAX}$ (Note 4)		0.1 0.3	0.3 1	% %
Ripple Rejection	RR	$V_I = 10\text{V}$, $f = 120\text{Hz}$ $C_{ADJ} = 0\mu\text{F}$ $V_I = 10\text{V}$, $f = 120\text{Hz}$ $C_{ADJ} = 10\mu\text{F}$		65 80		dB dB
Thermal Regulation		20ms		0.03	0.07	%/W
Adjustment Pin Current				50	100	μA
Adjustment Pin Current Change		$10\text{mA} \leq I_{OUT} \leq I_{MAX}$, $3\text{V} \leq (V_{IN} - V_{OUT}) \leq 40\text{V}$		0.2	5	μA
Temperature Stability		$T_{MIN} \leq T_J \leq T_{MAX}$		1		%
Long Term Stability		$T_J = 125^\circ\text{C}$, 1000 hrs		0.3	1	%
RMS Output Noise % of V_{OUT}		$10\text{Hz} \leq f \leq 10\text{KHz}$		0.003		%
Minimum Load Current		$(V_{IN} - V_{OUT}) = 40\text{V}$		3.5	5	mA
Maximum Load Current		$(V_{IN} - V_{OUT}) \leq 15\text{V}$ $P_D \leq P_{MAX}$ $(V_{IN} - V_{OUT}) \leq 40\text{V}$ $P_D \leq P_{MAX}$	1.5	2.2		A
				0.4		A

Application Notes:

The LM317 provides an internal reference voltage of 1.25V between the output and adjustments terminals. This is used to set a constant current flow across an external resistor divider show below, giving an output voltage VO of:

$$V_O = V_{REF} (1 + R_2 / R_1) + I_{ADJ} R_2$$

The device was designed to minimize the term I_{ADJ} (100 m A max) and to maintain it very constant with line and load changes. Usually, the error term $I_{ADJ} V R_2$ can be neglected. To obtain the previous requirement, all the regulator quiescent current is returned to the output terminal, imposing a minimum load current condition. If the load is insufficient, the output voltage will rise. Since the LM317 is a floating regulator and " sees" only the input- to- output differential voltage, supplies of very high voltage with respect to ground can be regulated as long as the maximum input- to- output differential is not exceeded. Furthermore, programmable regulator are easily obtainable and, by connecting a fixed resistor between the adjustment and output, the device can be used as a precision current regulator. In order to optimise the load regulation, the current set resistor R1 show below should be tied as close as possible to the regulator, while the ground terminal of R2 should be near the ground of the load to provide remote ground sensing. Performance may be improved with added capacitance as follow:

An input bypass capacitor of 0.1µF

An adjustment terminal to ground 10µF capacitor

to improve the ripple rejection of about 15 dB (C_{ADJ}).

An 1µF tantalium (or 25 µF Aluminium electrolytic) capacitor on the output to improve transient response. In additional to external capacitors, it is good practice to add protection diodes, as shown in below.

D1 protect the device against input short circuit, while D2 protect against output short circuit for capacitance discharging.

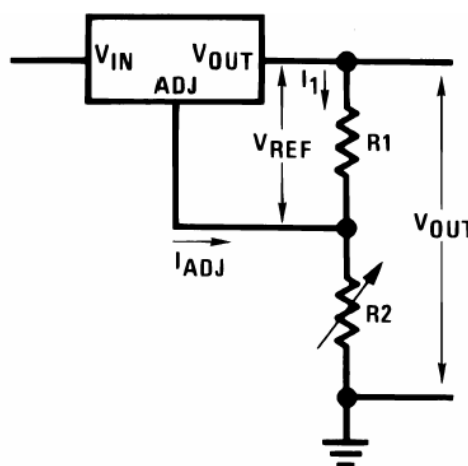
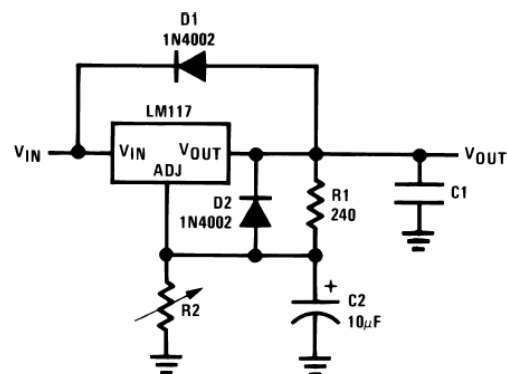

Advance Information- These data sheets contain descriptions of products that are in development. The specifications are based on the engineering calculations, computer simulations and/ or initial prototype evaluation.

Preliminary Information- These data sheets contain minimum and maximum specifications that are based on the initial device characterizations. These limits are subject to change upon the completion of the full characterization over the specified temperature and supply voltage ranges.

The application circuit examples are only to explain the representative applications of the devices and are not intended to guarantee any circuit design or permit any industrial property right to other rights to execute. Bay Linear takes no responsibility for any problems related to any industrial property right resulting from the use of the contents shown in the data book. Typical parameters can and do vary in different applications. Customer's technical experts must validate all operating parameters including "Typical" for each customer application.

LIFE SUPPORT AND NUCLEAR POLICY

Bay Linear products are not authorized for and should not be used within life support systems which are intended for surgical implants into the body to support or sustain life, in aircraft, space equipment, submarine, or nuclear facility applications without the specific written consent of Bay Linear President.
