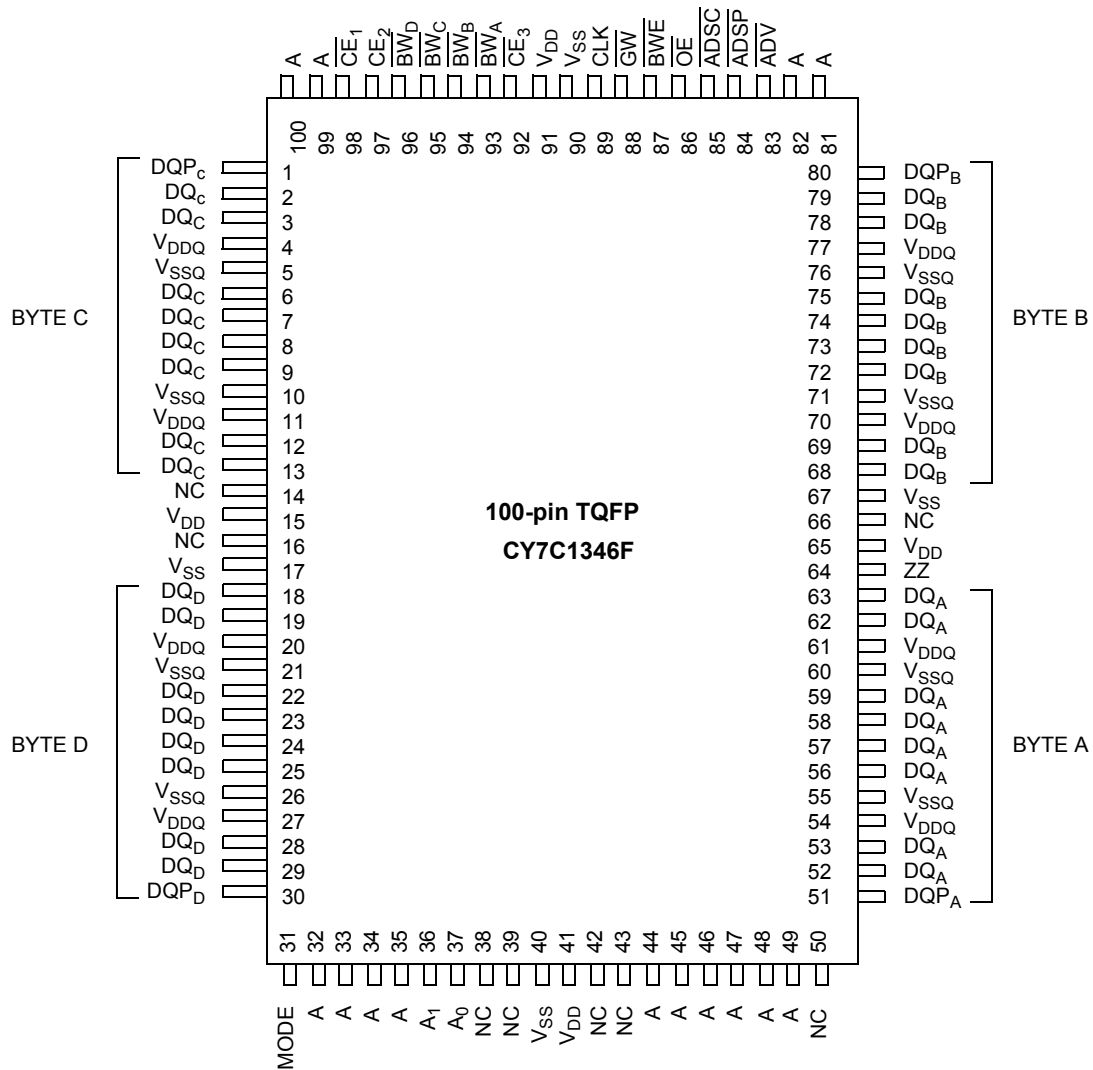

Selection Guide

	166 MHz	133 MHz	100 MHz	Unit
Maximum Access Time	3.5	4.0	4.5	ns
Maximum Operating Current	240	240	205	mA
Maximum CMOS Standby Current	40	40	40	mA

Pin Configuration

Pin Definitions

Name	TQFP	I/O	Description
A ₀ , A ₁ , A	37,36,32, 33,34,35, 36,37,44, 45,46,47, 48,49,81, 82,99,100	Input- Synchronous	Address Inputs used to select one of the 64K address locations. Sampled at the rising edge of the CLK if $\overline{\text{ADSP}}$ or $\overline{\text{ADSC}}$ is active LOW, and $\overline{\text{CE}}_1$, CE_2 , and CE_3 are sampled active. A ₁ , A ₀ feed the 2-bit counter.
$\overline{\text{BW}}_A$, $\overline{\text{BW}}_B$ $\overline{\text{BW}}_C$, $\overline{\text{BW}}_D$	93,94,95, 96	Input- Synchronous	Byte Write Select Inputs, active LOW. Qualified with $\overline{\text{BWE}}$ to conduct Byte Writes to the SRAM. Sampled on the rising edge of CLK.
$\overline{\text{GW}}$	88	Input- Synchronous	Global Write Enable Input, active LOW. When asserted LOW on the rising edge of CLK, a global Write is conducted (ALL bytes are written, regardless of the values on $\overline{\text{BW}}_{[A:D]}$ and BWE).
$\overline{\text{BWE}}$	87	Input- Synchronous	Byte Write Enable Input, active LOW. Sampled on the rising edge of CLK. This signal must be asserted LOW to conduct a Byte Write.
CLK	89	Input- Clock	Clock Input. Used to capture all synchronous inputs to the device. Also used to increment the burst counter when $\overline{\text{ADV}}$ is asserted LOW, during a burst operation.
$\overline{\text{CE}}_1$	98	Input- Synchronous	Chip Enable 1 Input, active LOW. Sampled on the rising edge of CLK. Used in conjunction with CE_2 and CE_3 to select/deselect the device. $\overline{\text{ADSP}}$ is ignored if $\overline{\text{CE}}_1$ is HIGH.
CE_2	97	Input- Synchronous	Chip Enable 2 Input, active HIGH. Sampled on the rising edge of CLK. Used in conjunction with CE_1 and CE_3 to select/deselect the device.
$\overline{\text{CE}}_3$	92	Input- Synchronous	Chip Enable 3 Input, active LOW. Sampled on the rising edge of CLK. Used in conjunction with CE_1 and CE_2 to select/deselect the device.
$\overline{\text{OE}}$	86	Input- Asynchronous	Output Enable, asynchronous input, active LOW. Controls the direction of the I/O pins. When LOW, the I/O pins behave as outputs. When deasserted HIGH, I/O pins are three-stated, and act as input data pins. $\overline{\text{OE}}$ is masked during the first clock of a Read cycle when emerging from a deselected state.
$\overline{\text{ADV}}$	83	Input- Synchronous	Advance Input signal, sampled on the rising edge of CLK, active LOW. When asserted, it automatically increments the address in a burst cycle.
$\overline{\text{ADSP}}$	84	Input- Synchronous	Address Strobe from Processor, sampled on the rising edge of CLK, active LOW. When asserted LOW, A is captured in the address registers. A ₁ , A ₀ are also loaded into the burst counter. When $\overline{\text{ADSP}}$ and $\overline{\text{ADSC}}$ are both asserted, only $\overline{\text{ADSP}}$ is recognized. $\overline{\text{ADSP}}$ is ignored when $\overline{\text{CE}}_1$ is deasserted HIGH.
$\overline{\text{ADSC}}$	85	Input- Synchronous	Address Strobe from Controller, sampled on the rising edge of CLK, active LOW. When asserted LOW, A is captured in the address registers. A ₁ , A ₀ are also loaded into the burst counter. When $\overline{\text{ADSP}}$ and $\overline{\text{ADSC}}$ are both asserted, only $\overline{\text{ADSP}}$ is recognized.
ZZ	64	Input- Asynchronous	ZZ "Sleep" Input, active HIGH. This input, when HIGH places the device in a non-time-critical "sleep" condition with data integrity preserved. For normal operation, this pin has to be LOW or left floating. ZZ pin has an internal pull-down.
DQ _A , DQ _B DQ _C , DQ _D DQP _A , DQP _B , DQP _C , DQP _D	52,53,56,57, 58,59,62,63, 68, 69,72,73, 74,75,78,79, 2,3,6,7,8,9, 12,13,18,19, 22,23,24,25, 28,29,51, 80,1,30	I/O- Synchronous	Bidirectional Data I/O lines. As inputs, they feed into an on-chip data register that is triggered by the rising edge of CLK. As outputs, they deliver the data contained in the memory location specified by "A" during the previous clock rise of the Read cycle. The direction of the pins is controlled by $\overline{\text{OE}}$. When $\overline{\text{OE}}$ is asserted LOW, the pins behave as outputs. When HIGH, DQs and DQPs are placed in a three-state condition.

Pin Definitions (continued)

Name	TQFP	I/O	Description
V _{DD}	15,41,65,91	Power Supply	Power supply inputs to the core of the device.
V _{SS}	17,40,67,90	Ground	Ground for the core of the device.
V _{DDQ}	4,11,20,27,54,61,70,77	I/O Power Supply	Power supply for the I/O circuitry.
V _{SSQ}	5,10,21,26,55,60,71,76	I/O Ground	Ground for the I/O circuitry.
MODE	31	Input-Static	Selects Burst Order. When tied to GND selects linear burst sequence. When tied to V _{DD} or left floating selects interleaved burst sequence. This is a strap pin and should remain static during device operation. Mode Pin has an internal pull-up.
NC	14,16,38,39,42,43,50,66		No Connects. Not internally connected to the die.

Functional Overview

All synchronous inputs pass through input registers controlled by the rising edge of the clock. All data outputs pass through output registers controlled by the rising edge of the clock.

The CY7C1346F supports secondary cache in systems utilizing either a linear or interleaved burst sequence. The interleaved burst order supports Pentium and i486™ processors. The linear burst sequence is suited for processors that utilize a linear burst sequence. The burst order is user selectable, and is determined by sampling the MODE input. Accesses can be initiated with either the Processor Address Strobe (ADSP) or the Controller Address Strobe (ADSC). Address advancement through the burst sequence is controlled by the ADV input. A two-bit on-chip wraparound burst counter captures the first address in a burst sequence and automatically increments the address for the rest of the burst access.

Byte Write operations are qualified with the Byte Write Enable (BWE) and Byte Write Select (BW_[A:D]) inputs. A Global Write Enable (GW) overrides all Byte Write inputs and writes data to all four bytes. All writes are simplified with on-chip synchronous self-timed Write circuitry.

Three synchronous Chip Selects (\overline{CE}_1 , CE₂, \overline{CE}_3) and an asynchronous Output Enable (\overline{OE}) provide for easy bank selection and output three-state control. ADSP is ignored if CE₁ is HIGH.

Single Read Accesses

This access is initiated when the following conditions are satisfied at clock rise: (1) ADSP or ADSC is asserted LOW, (2) \overline{CE}_1 , CE₂, \overline{CE}_3 are all asserted active, and (3) the Write signals (GW, BWE) are all deasserted HIGH. ADSP is ignored if \overline{CE}_1 is HIGH. The address presented to the address inputs (A) is stored into the address advancement logic and the address register while being presented to the memory array. The corresponding data is allowed to propagate to the input of the output registers. At the rising edge of the next clock the

data is allowed to propagate through the output register and onto the data bus within t_{CO} if OE is active LOW. The only exception occurs when the SRAM is emerging from a deselected state to a selected state, its outputs are always three-stated during the first cycle of the access. After the first cycle of the access, the outputs are controlled by the OE signal. Consecutive single Read cycles are supported. Once the SRAM is deselected at clock rise by the chip select and either ADSP or ADSC signals, its output will three-state immediately.

Single Write Accesses Initiated by ADSP

This access is initiated when both of the following conditions are satisfied at clock rise: (1) ADSP is asserted LOW, and (2) CE₁, CE₂, CE₃ are all asserted active. The address presented to A is loaded into the address register and the address advancement logic while being delivered to the RAM array. The Write signals (GW, BWE, and BW_[A:D]) and ADV inputs are ignored during this first cycle.

ADSP-triggered Write accesses require two clock cycles to complete. If GW is asserted LOW on the second clock rise, the data presented to the DQ inputs is written into the corresponding address location in the memory array. If GW is HIGH, then the Write operation is controlled by BWE and BW_[A:D] signals. The CY7C1346F provides Byte Write capability that is described in the Write Cycle Descriptions table. Asserting the Byte Write Enable input (BWE) with the selected Byte Write (BW_[A:D]) input, will selectively write to only the desired bytes. Bytes not selected during a Byte Write operation will remain unaltered. A synchronous self-timed Write mechanism has been provided to simplify the Write operations.

Because the CY7C1346F is a common I/O device, the Output Enable (\overline{OE}) must be deasserted HIGH before presenting data to the DQ inputs. Doing so will three-state the output drivers. As a safety precaution, DQ are automatically three-stated whenever a Write cycle is detected, regardless of the state of OE.

Single Write Accesses Initiated by ADSC

ADSC Write accesses are initiated when the following conditions are satisfied: (1) $\overline{\text{ADSC}}$ is asserted LOW, (2) $\overline{\text{ADSP}}$ is deasserted HIGH, (3) CE_1 , CE_2 , CE_3 are all asserted active, and (4) the appropriate combination of the Write inputs ($\overline{\text{GW}}$, $\overline{\text{BWE}}$, and $\overline{\text{BW}}_{[A,D]}$) are asserted active to conduct a Write to the desired byte(s). ADSC-triggered Write accesses require a single clock cycle to complete. The address presented to A is loaded into the address register and the address advancement logic while being delivered to the memory array. The ADV input is ignored during this cycle. If a global Write is conducted, the data presented to DQ is written into the corresponding address location in the memory core. If a Byte Write is conducted, only the selected bytes are written. Bytes not selected during a Byte Write operation will remain unaltered. A synchronous self-timed Write mechanism has been provided to simplify the Write operations.

Because the CY7C1346F is a common I/O device, the Output Enable (OE) must be deserted HIGH before presenting data to the DQ inputs. Doing so will three-state the output drivers. As a safety precaution, DQs are automatically three-stated whenever a Write cycle is detected, regardless of the state of OE.

Burst Sequences

The CY7C1346F provides a two-bit wraparound counter, fed by A_1 , A_0 , that implements either an interleaved or linear burst sequence. The interleaved burst sequence is designed specifically to support Intel Pentium applications. The linear burst sequence is designed to support processors that follow a linear burst sequence. The burst sequence is user selectable through the MODE input.

Asserting ADV LOW at clock rise will automatically increment the burst counter to the next address in the burst sequence. Both Read and Write burst operations are supported.

ZZ Mode Electrical Characteristics

Parameter	Description	Test Conditions	Min.	Max.	Unit
I_{DDZZ}	Snooze mode standby current	$ZZ \geq V_{DD} - 0.2V$		40	mA
t_{ZZS}	Device operation to ZZ	$ZZ \geq V_{DD} - 0.2V$		$2t_{CYC}$	ns
t_{ZZREC}	ZZ recovery time	$ZZ \leq 0.2V$	$2t_{CYC}$		ns
t_{ZZI}	ZZ Active to snooze current	This parameter is sampled		$2t_{CYC}$	ns
t_{RZZI}	ZZ Inactive to exit snooze current	This parameter is sampled	0		ns

Interleaved Burst Address Table (MODE = Floating or V_{DD})

First Address A_1, A_0	Second Address A_1, A_0	Third Address A_1, A_0	Fourth Address A_1, A_0
00	01	10	11
01	00	11	10
10	11	00	01
11	10	01	00

Linear Burst Address Table (MODE = GND)

First Address A_1, A_0	Second Address A_1, A_0	Third Address A_1, A_0	Fourth Address A_1, A_0
00	01	10	11
01	10	11	00
10	11	00	01
11	00	01	10

Sleep Mode

The ZZ input pin is an asynchronous input. Asserting ZZ places the SRAM in a power conservation "sleep" mode. Two clock cycles are required to enter into or exit from this "sleep" mode. While in this mode, data integrity is guaranteed. Accesses pending when entering the "sleep" mode are not considered valid nor is the completion of the operation guaranteed. The device must be deselected prior to entering the "sleep" mode. $\overline{\text{CE}}_1$, CE_2 , $\overline{\text{CE}}_3$, $\overline{\text{ADSP}}$, and $\overline{\text{ADSC}}$ must remain inactive for the duration of t_{ZZREC} after the ZZ input returns LOW.

Truth Table [2, 3, 4, 5, 6, 7]

Next Cycle	Add. Used	\overline{CE}_1	CE_2	\overline{CE}_3	ZZ	\overline{ADSP}	\overline{ADSC}	\overline{ADV}	WRITE	\overline{OE}	CLK	DQ
Deselect Cycle, Power-down	None	H	X	X	L	X	L	X	X	X	L-H	three-state
Deselect Cycle, Power-down	None	L	L	X	L	L	X	X	X	X	L-H	three-state
Deselect Cycle, Power-down	None	L	X	H	L	L	X	X	X	X	L-H	three-state
Deselect Cycle, Power-down	None	L	L	X	L	H	L	X	X	X	L-H	three-state
Deselect Cycle, Power-down	None	L	X	H	L	H	L	X	X	X	L-H	three-state
Snooze Mode, Power-down	None	X	X	X	H	X	X	X	X	X	X	three-state
READ Cycle, Begin Burst	External	L	H	L	L	L	X	X	X	L	L-H	Q
READ Cycle, Begin Burst	External	L	H	L	L	L	X	X	X	H	L-H	three-state
WRITE Cycle, Begin Burst	External	L	H	L	L	H	L	X	L	X	L-H	D
READ Cycle, Begin Burst	External	L	H	L	L	H	L	X	H	L	L-H	Q
READ Cycle, Begin Burst	External	L	H	L	L	H	L	X	H	H	L-H	three-state
READ Cycle, Continue Burst	Next	X	X	X	L	H	H	L	H	L	L-H	Q
READ Cycle, Continue Burst	Next	X	X	X	L	H	H	L	H	H	L-H	three-state
READ Cycle, Continue Burst	Next	H	X	X	L	X	H	L	H	L	L-H	Q
READ Cycle, Continue Burst	Next	H	X	X	L	X	H	L	H	H	L-H	three-state
WRITE Cycle, Continue Burst	Next	X	X	X	L	H	H	L	L	X	L-H	D
WRITE Cycle, Continue Burst	Next	H	X	X	L	X	H	L	L	X	L-H	D
READ Cycle, Suspend Burst	Current	X	X	X	L	H	H	H	H	L	L-H	Q
READ Cycle, Suspend Burst	Current	X	X	X	L	H	H	H	H	H	L-H	three-state

Notes:

- X = "Don't Care." H = Logic HIGH, L = Logic LOW.
- $\overline{WRITE} = L$ when any one or more Byte Write Enable signals ($\overline{BW}_A, \overline{BW}_B, \overline{BW}_C, \overline{BW}_D$) and $\overline{BWE} = L$ or $\overline{GW} = L$. $\overline{WRITE} = H$ when all Byte Write Enable signals ($\overline{BW}_A, \overline{BW}_B, \overline{BW}_C, \overline{BW}_D$), \overline{BWE} , $\overline{GW} = H$.
- The DQ pins are controlled by the current cycle and the \overline{OE} signal. \overline{OE} is asynchronous and is not sampled with the clock.
- \overline{CE}_1 , CE_2 , and \overline{CE}_3 are available only in the TQFP package.
- The SRAM always initiates a read cycle when \overline{ADSP} is asserted, regardless of the state of \overline{GW} , \overline{BWE} , or $\overline{BW}_{[A,D]}$. Writes may occur only on subsequent clocks after the \overline{ADSP} or with the assertion of \overline{ADSC} . As a result, \overline{OE} must be driven HIGH prior to the start of the Write cycle to allow the outputs to Three-State. \overline{OE} is a don't care for the remainder of the Write cycle.
- \overline{OE} is asynchronous and is not sampled with the clock rise. It is masked internally during Write cycles. During a Read cycle all data bits are Three-State when \overline{OE} is inactive or when the device is deselected, and all data bits behave as output when \overline{OE} is active (LOW).

Truth Table (continued)[2, 3, 4, 5, 6, 7]

Next Cycle	Add. Used	\overline{CE}_1	CE_2	\overline{CE}_3	ZZ	\overline{ADSP}	\overline{ADSC}	\overline{ADV}	WRITE	\overline{OE}	CLK	DQ
READ Cycle, Suspend Burst	Current	H	X	X	L	X	H	H	H	L	L-H	Q
READ Cycle, Suspend Burst	Current	H	X	X	L	X	H	H	H	H	L-H	three-state
WRITE Cycle, Suspend Burst	Current	X	X	X	L	H	H	H	L	X	L-H	D
WRITE Cycle, Suspend Burst	Current	H	X	X	L	X	H	H	L	X	L-H	D

Truth Table for Read/Write^[2, 3]

Function	\overline{GW}	\overline{BWE}	\overline{BW}_D	\overline{BW}_C	\overline{BW}_B	\overline{BW}_A
Read	H	H	X	X	X	X
Read	H	L	H	H	H	H
Write Byte A – (DQ _A and DQP _A)	H	L	H	H	H	L
Write Byte B – (DQ _B and DQP _B)	H	L	H	H	L	H
Write Bytes B, A	H	L	H	H	L	L
Write Byte C – (DQ _C and DQP _C)	H	L	H	L	H	H
Write Bytes C, A	H	L	H	L	H	L
Write Bytes C, B	H	L	H	L	L	H
Write Bytes C, B, A	H	L	H	L	L	L
Write Byte D – (DQ _D and DQP _D)	H	L	L	H	H	H
Write Bytes D, A	H	L	L	H	H	L
Write Bytes D, B	H	L	L	H	L	H
Write Bytes D, B, A	H	L	L	H	L	L
Write Bytes D, C	H	L	L	L	H	H
Write Bytes D, C, A	H	L	L	L	H	L
Write Bytes D, C, B	H	L	L	L	L	H
Write All Bytes	H	L	L	L	L	L
Write All Bytes	L	X	X	X	X	X

Maximum Ratings

(Above which the useful life may be impaired. For user guidelines, not tested.)

Storage Temperature -65°C to +150°C
 Ambient Temperature with Power Applied..... -55°C to +125°C
 Supply Voltage on V_{DD} Relative to GND..... -0.5V to +4.6V
 DC Voltage Applied to Outputs in Three-State -0.5V to $V_{DDQ} + 0.5V$
 DC Input Voltage..... -0.5V to $V_{DD} + 0.5V$

Current into Outputs (LOW)..... 20 mA
 Static Discharge Voltage..... >2001V (per MIL-STD-883, Method 3015)
 Latch-up Current..... >200 mA

Operating Range

Range	Ambient Temperature	V_{DD}	V_{DDQ}
Commercial	0°C to +70°C	3.3V -5%/+10%	3.3V -5% to V_{DD}

Electrical Characteristics Over the Operating Range^[8, 9]

Parameter	Description	Test Conditions	Min.	Max.	Unit
V_{DD}	Power Supply Voltage		3.135	3.6	V
V_{DDQ}	I/O Supply Voltage		3.135	V_{DD}	V
V_{OH}	Output HIGH Voltage	$V_{DDQ} = 3.3V, V_{DD} = \text{Min.}, I_{OH} = -4.0 \text{ mA}$	2.4		V
V_{OL}	Output LOW Voltage	$V_{DDQ} = 3.3V, V_{DD} = \text{Min.}, I_{OL} = 8.0 \text{ mA}$		0.4	V
V_{IH}	Input HIGH Voltage ^[8]	$V_{DDQ} = 3.3V$	2.0	$V_{DD} + 0.3V$	V
V_{IL}	Input LOW Voltage ^[8]	$V_{DDQ} = 3.3V$	-0.3	0.8	V
I_X	Input Load Current except ZZ and MODE	$GND \leq V_I \leq V_{DDQ}$	-5	5	μA
	Input Current of MODE	Input = V_{SS}	-30		μA
		Input = V_{DD}		5	μA
	Input Current of ZZ	Input = V_{SS}	-5		μA
Input = V_{DD}			30	μA	
I_{OZ}	Output Leakage Current	$GND \leq V_I \leq V_{DDQ}$, Output Disabled	-5	5	μA
I_{DD}	V_{DD} Operating Supply Current	$V_{DD} = \text{Max.}, I_{OUT} = 0 \text{ mA}, f = f_{MAX} = 1/t_{CYC}$	6-ns cycle, 166 MHz	240	mA
			7.5-ns cycle, 133MHz	225	mA
			10-ns cycle, 100 MHz	205	mA
I_{SB1}	Automatic CS Power-down Current—TTL Inputs	$V_{DD} = \text{Max.}$, Device Deselected, $V_{IN} \geq V_{IH}$ or $V_{IN} \leq V_{IL}$ $f = f_{MAX} = 1/t_{CYC}$	6-ns cycle, 166 MHz	100	mA
			7.5-ns cycle, 133 MHz	90	mA
			10-ns cycle, 100 MHz	80	mA
I_{SB2}	Automatic CS Power-down Current—CMOS Inputs	$V_{DD} = \text{Max.}$, Device Deselected, $V_{IN} \leq 0.3V$ or $V_{IN} \geq V_{DDQ} - 0.3V, f = 0$	All speeds	40	mA
I_{SB3}	Automatic CS Power-down Current—CMOS Inputs	$V_{DD} = \text{Max.}$, Device Deselected, or $V_{IN} \leq 0.3V$ or $V_{IN} \geq V_{DDQ} - 0.3V$ $f = f_{MAX} = 1/t_{CYC}$	6-ns cycle, 166 MHz	85	mA
			7.5-ns cycle, 133 MHz	75	mA
			10-ns cycle, 100 MHz	65	mA
I_{SB4}	Automatic CS Power-down Current—TTL Inputs	$V_{DD} = \text{Max.}$, Device Deselected, $V_{IN} \geq V_{IH}$ or $V_{IN} \leq V_{IL}, f = 0$	All speeds	45	mA

Notes:

8. Overshoot: $V_{IH}(AC) < V_{DD} + 1.5V$ (Pulse width less than $t_{CYC}/2$), undershoot: $V_{IL}(AC) > -2V$ (Pulse width less than $t_{CYC}/2$).
 9. $T_{Power-up}$: Assumes a linear ramp from 0V to $V_{DD}(\text{min.})$ within 200 ms. During this time $V_{IH} \leq V_{DD}$ and $V_{DDQ} \leq V_{DD}$.

Thermal Resistance^[10]

Parameter	Description	Test Conditions	TQFP Package	Unit
Θ_{JA}	Thermal Resistance (Junction to Ambient)	Test conditions follow standard test methods and procedures for measuring thermal impedance, per EIA/JESD51	41.83	°C/W
Θ_{JC}	Thermal Resistance (Junction to Case)		9.99	°C/W

Capacitance^[10]

Parameter	Description	Test Conditions	Max.	Unit
C_{IN}	Input Capacitance	$T_A = 25^\circ\text{C}$, $f = 1\text{ MHz}$, $V_{DD} = 3.3\text{V}$, $V_{DDQ} = 3.3\text{V}$	5	pF
C_{CLK}	Clock Input Capacitance		5	pF
$C_{I/O}$	Input/Output Capacitance		5	pF

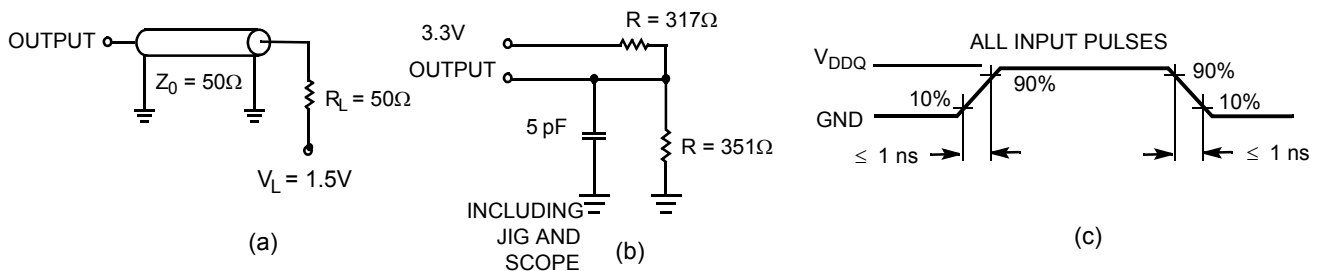
AC Test Loads and Waveforms
3.3V I/O Test Load

Note:

10. Tested initially and after any design or process change that may affect these parameters.

Switching Characteristics Over the Operating Range^[11, 12]

Parameter	Description	166 MHz		133 MHz		100 MHz		Unit
		Min.	Max.	Min.	Max.	Min.	Max.	
t _{POWER}	V _{DD} (Typical) to the First Access ^[13]	1		1		1		ms
Clock								
t _{CYC}	Clock Cycle Time	6.0		7.5		3.5		ns
t _{CH}	Clock HIGH	2.5		3.0		3.5		ns
t _{CL}	Clock LOW	2.5		3.0		1.5		ns
Output Times								
t _{CO}	Data Output Valid after CLK Rise		3.5		4.0		4.5	ns
t _{DOH}	Data Output Hold after CLK Rise	2.0		2.0		2.0		ns
t _{CLZ}	Clock to Low-Z ^[14, 15, 16]	0		0		1.5		ns
t _{CHZ}	Clock to High-Z ^[14, 15, 16]		3.5		4.0	0.5		ns
t _{OEV}	\overline{OE} LOW to Output Valid		3.5		4.5	1.5		ns
t _{OELZ}	\overline{OE} LOW to Output Low-Z ^[14, 15, 16]	0		0		0.5		ns
t _{OEHZ}	\overline{OE} HIGH to Output High-Z ^[14, 15, 16]		3.5		4.0	1.5		ns
Set-up Times								
t _{AS}	Address Set-up before CLK Rise	1.5		1.5		1.5		ns
t _{ADS}	\overline{ADSC} , \overline{ADSP} Set-up before CLK Rise	1.5		1.5		0.5		ns
t _{ADVS}	\overline{ADV} Set-up before CLK Rise	1.5		1.5			4.5	ns
t _{WES}	\overline{GW} , \overline{BWE} , $\overline{BW}_{[A:D]}$ Set-up before CLK Rise	1.5		1.5		0		ns
t _{DS}	Data Input Set-up before CLK Rise	1.5		1.5			4.5	ns
t _{CES}	Chip Enable Set-Up before CLK Rise	1.5		1.5		0		ns
Hold Times								
t _{AH}	Address Hold after CLK Rise	0.5		0.5		1		ns
t _{ADH}	\overline{ADSP} , \overline{ADSC} Hold after CLK Rise	0.5		0.5		10		ns
t _{ADVH}	\overline{ADV} Hold after CLK Rise	0.5		0.5		3.5		ns
t _{WEH}	\overline{GW} , \overline{BWE} , $\overline{BW}_{[A:D]}$ Hold after CLK Rise	0.5		0.5		3.5		ns
t _{DH}	Data Input Hold after CLK Rise	0.5		0.5		1.5		ns
t _{CEH}	Chip Enable Hold after CLK Rise	0.5		0.5		0.5		ns

Notes:

11. Timing reference level is 1.5V when V_{DDQ} = 3.3V.
12. Test conditions shown in (a) of AC Test Loads unless otherwise noted.
13. This part has a voltage regulator internally; t_{POWER} is the time that the power needs to be supplied above V_{DD}(minimum) initially before a Read or Write operation can be initiated.
14. t_{CHZ}, t_{CLZ}, t_{OELZ}, and t_{OEHZ} are specified with AC test conditions shown in part (b) of AC Test Loads. Transition is measured ± 200 mV from steady-state voltage.
15. At any given voltage and temperature, t_{OEHZ} is less than t_{OELZ} and t_{CHZ} is less than t_{CLZ} to eliminate bus contention between SRAMs when sharing the same data bus. These specifications do not imply a bus contention condition, but reflect parameters guaranteed over worst case user conditions. Device is designed to achieve High-Z prior to Low-Z under the same system conditions.
16. This parameter is sampled and not 100% tested.

Switching Waveforms

Read Cycle Timing^[17]

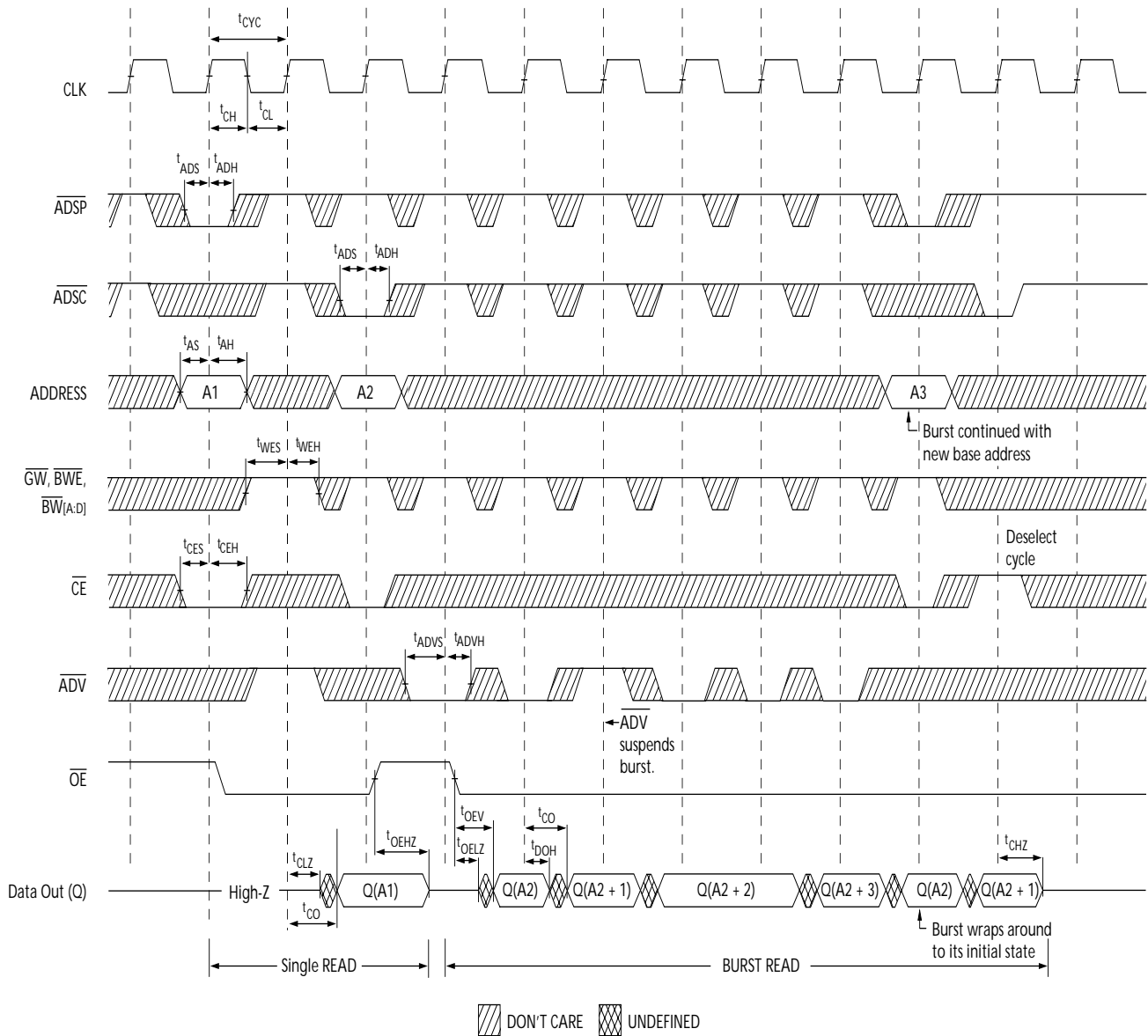

Note:

17. On this diagram, when \overline{CE} is LOW, \overline{CE}_1 is LOW, CE_2 is HIGH and \overline{CE}_3 is LOW. When \overline{CE} is HIGH, \overline{CE}_1 is HIGH or CE_2 is LOW or \overline{CE}_3 is HIGH.

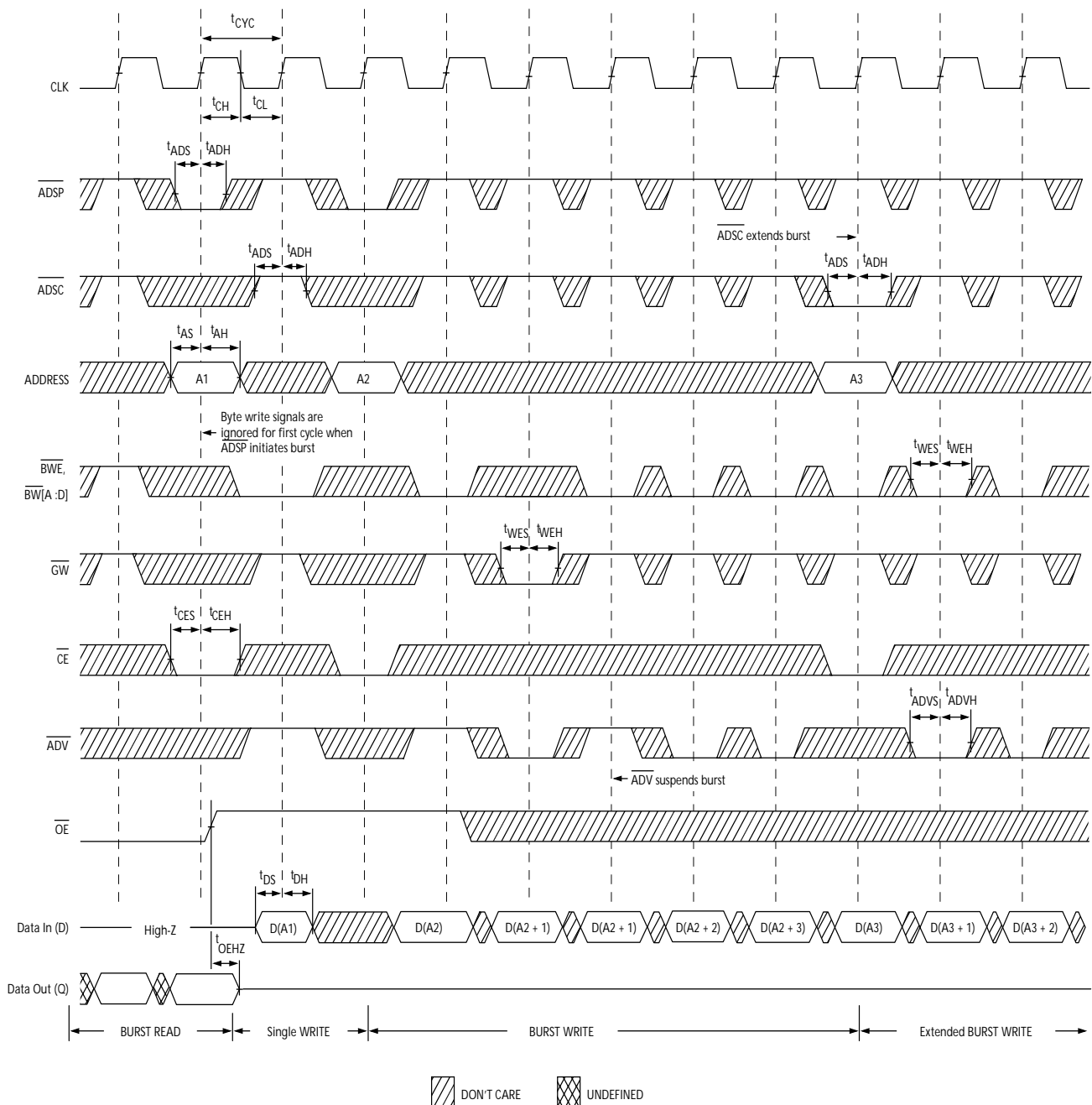
Switching Waveforms (continued)
Write Cycle Timing^[17, 18]

Note:

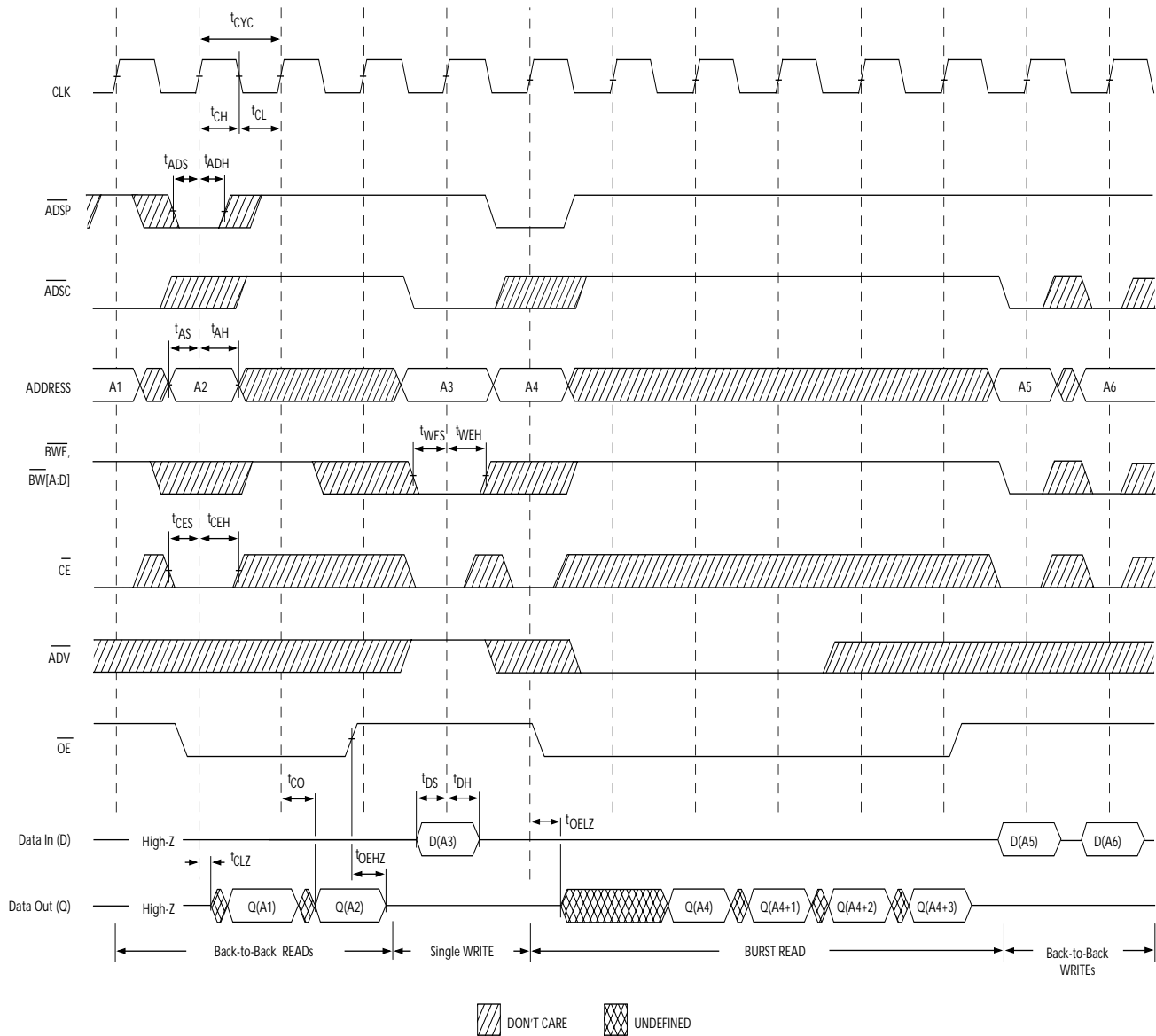
18. Full width Write can be initiated by either \overline{GW} LOW; or by \overline{GW} HIGH, \overline{BWE} LOW and $\overline{BW}_{[A:D]}$ LOW.

Switching Waveforms (continued)
Read/Write Cycle Timing^[17, 19, 20]

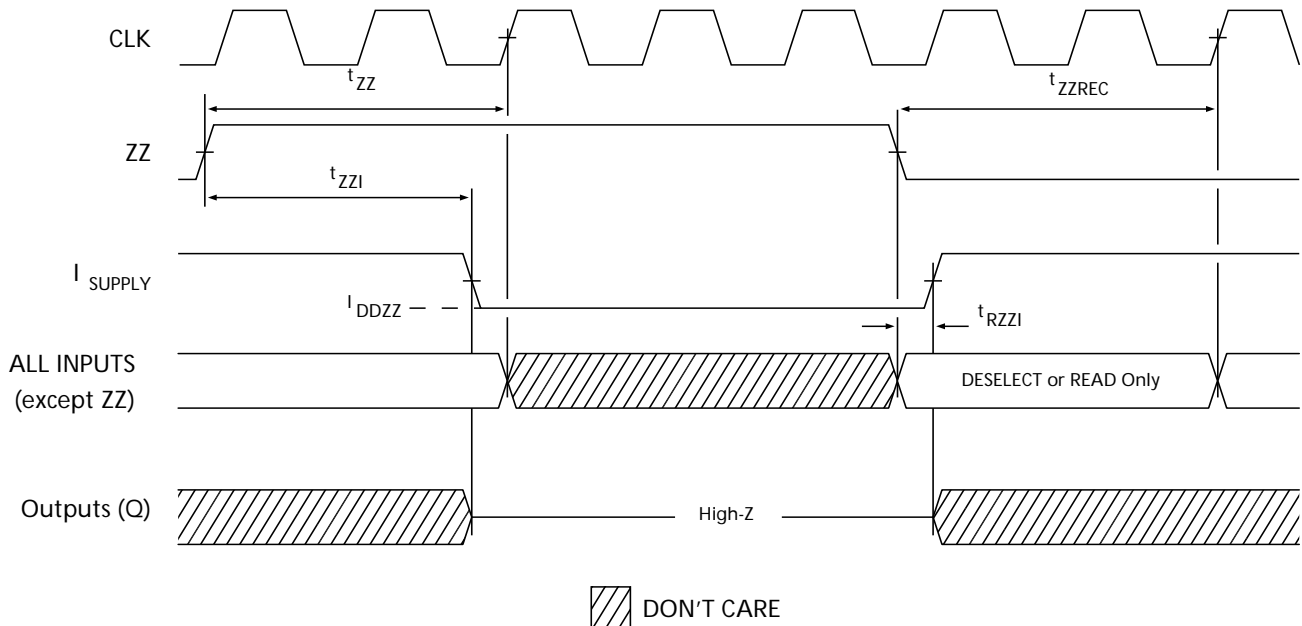
Notes:

19. The data bus (Q) remains in High-Z following a Write cycle unless an \overline{ADSP} , \overline{ADSC} , or \overline{ADV} cycle is performed.
20. \overline{GW} is HIGH.

Switching Waveforms (continued)
ZZ Mode Timing [21, 22]

Notes:

- 21. Device must be deselected when entering ZZ mode. See Cycle Descriptions table for all possible signal conditions to deselect the device.
- 22. DQs are in High-Z when exiting ZZ sleep mode.

Ordering Information

Speed (MHz)	Ordering Code	Package Name	Package Type	Operating Range
166	CY7C1346F-166AC	A101	100-lead Thin Quad Flat Pack	Commercial
133	CY7C1346F-133AC	A101	100-lead Thin Quad Flat Pack	
100	CY7C1346F-100AC	A101	100-lead Thin Quad Flat Pack	

Package Diagrams
100-pin Thin Plastic Quad Flatpack (14 x 20 x 1.4 mm) A101

DIMENSIONS ARE IN MILLIMETERS.

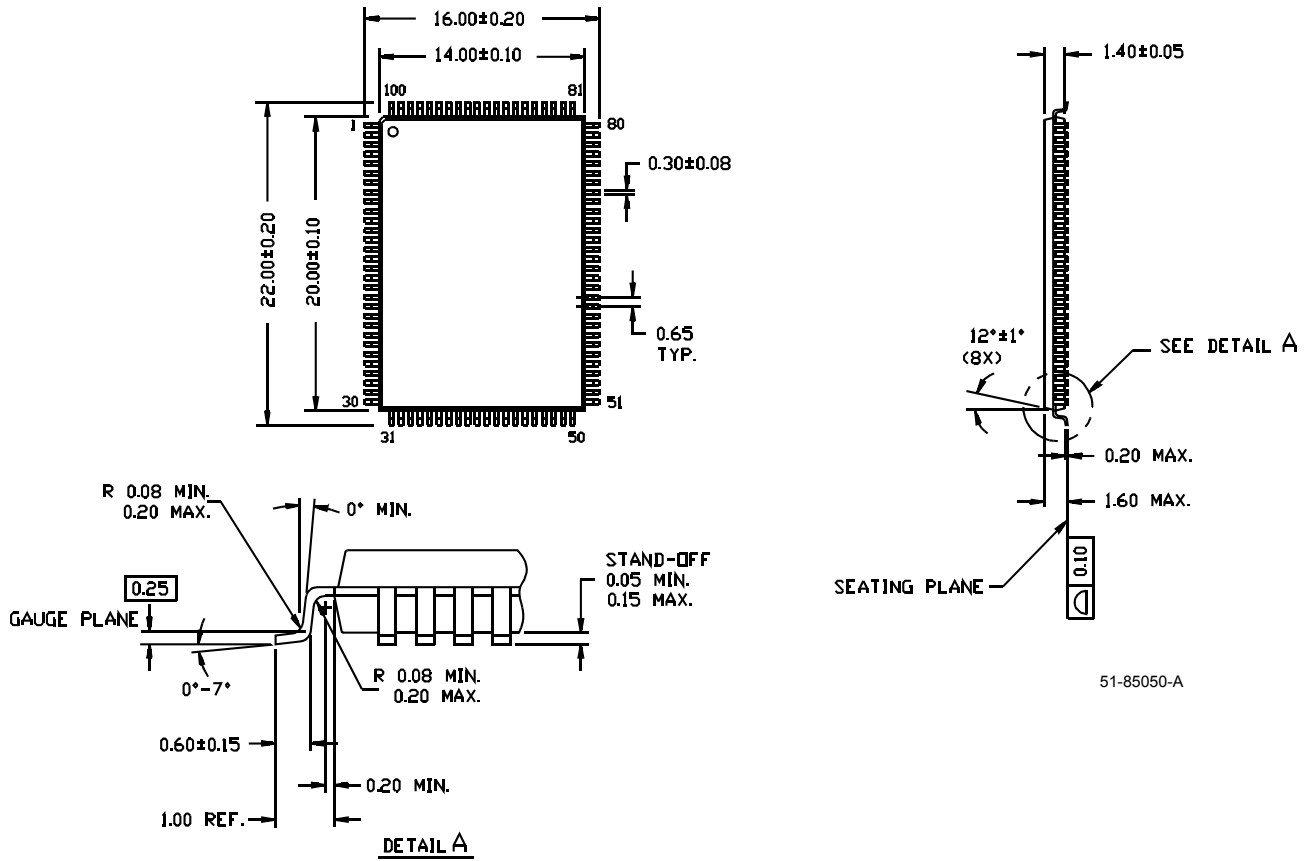

51-85050-A

i486 is a trademark, and Intel and Pentium are registered trademarks, of Intel Corporation. PowerPC is a registered trademark of IBM Corporation. All product and company names mentioned in this document may be trademarks of their respective holders.

Document History Page

Document Title: CY7C1346F 2-Mbit (64K x 36) Pipelined Sync SRAM
Document Number: 38-05384

REV.	ECN NO.	Issue Date	Orig. of Change	Description of Change
**	200661	See ECN	NJY	New Data Sheet
*A	213342	See ECN	VBL	Update Ordering Info section: add -100AC & -166AC