

TELEPHONE RINGING DETECTOR

AN AT & T PRODUCT

PRELIMINARY DATA

- MEETS BOTH TYPE A AND B RINGING REQUIREMENTS ($40 V_{RMS} \leq V_{IN} \leq 150 V_{RMS}$, $15 \text{ Hz} \leq F_{IN} \leq 68 \text{ Hz}$)
- OPERATES ON LESS THAN 1 mA FROM THE TELEPHONE LOOP
- INTERNAL POLARITY GUARD PROVIDES 1500 V LIGHTNING SURGE PROTECTION WHEN CONNECTED AS IN FIG. 11 AND 12
- IMMUNE TO ROTARY DIAL PULSING (BELL TAP)

MINIDIP A



ORDER CODE : LB 1006AB

PIN CONNECTION

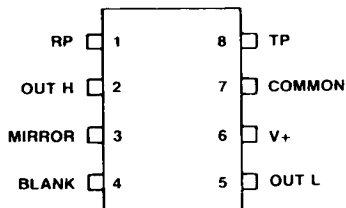

S-10707

DESCRIPTION

The LB1006 provides ringing detection functions from the Tip-ring pair of a telephone loop. This device provides approximately 1 mA output current for two types of output drivers. The output can be connected to either an opto-isolator device or to a logic interface with a microprocessor.

Figure 1 : Functional Diagram.

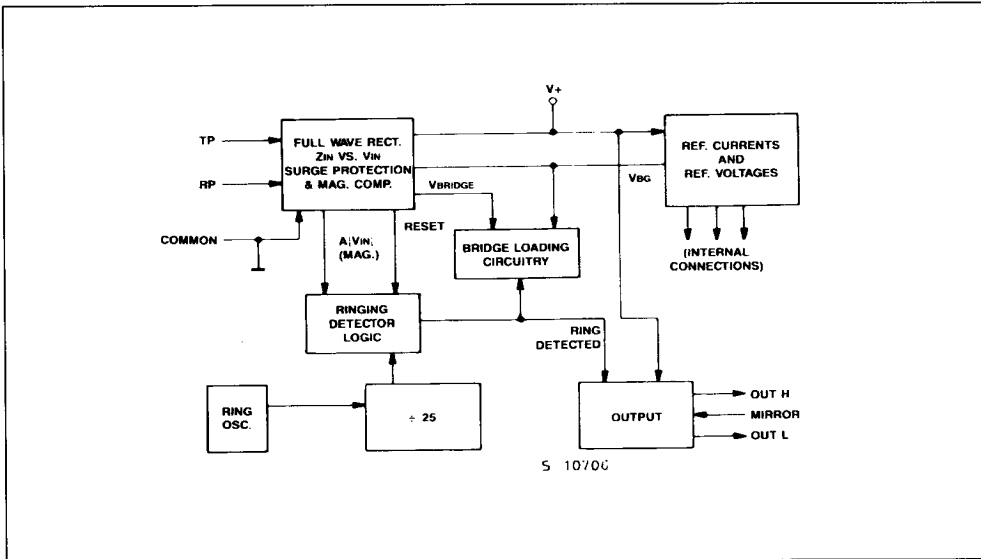

PIN DESCRIPTION

N°	Symbol	Description
8	TIP	AC Input Signal from Telephone Line
1	RING	AC Input Signal from Telephone Line
2	OUTH	Sources Current when ringing is detected
3	MIRROR	Mirror Current from OUTH to Activate Pin OUTL
5	OUTL	Sinks Current when ringing is detected
6	V+	Internal Supply Voltage. This voltage is usually derived from the AC signal which is present on the Tip-ring pair. This pin must have a 10 μ F capacitor to common for energy storage and «smoothing» purposes. For «stand alone application», an external voltage may be used to bias this pin.
7	GND	Ground
4	NC	No Connection

ABSOLUTE MAXIMUM RATINGS

Symbol	Parameter	Value	Unit
V*	Supply Voltage (ref to GND)	30	V
OUTH	Supply Voltage (ref to GND)	30	V
OUTL	Supply Voltage (ref to GND)	30	V
TIP	Voltage (tip-ring)	± 30	V
I _O	Operating Current (tip-ring)	± 100	mA
I _{MIR}	Mirror Current	2.0	mA
T _A	Ambient Operating Temperature Range	- 20 to + 75	°C
T _{stg}	Storage Temperature Range	- 40 to + 125	°C
-	Pin Temperature (soldering 15 sec)	300	°C
P _D	Power Dissipation (package limitation)	600	mW

Stresses in excess of those listed under "Absolute Maximum Ratings" may cause permanent damage to the device. This is a stress rating only and functional operation of the device at these or any other conditions in excess of those indicated in the operational sections of this specification is not implied. Exposure to absolute maximum rating conditions for extended periods may affect device reliability.

ELECTRICAL CHARACTERISTICS(at 25 °C unless otherwise specified)

Parameter	Test Conditions	Min.	Typ.	Max.	Unit
Power Supply Current	V* = 28 V (see fig. 2)	200	365	900	μA
Power Supply Current	V* = 15 V (see fig. 2)	200	360	800	
Tip-ring Current	V _{TIP-RING} = 4.5 V (see fig. 3)	-	30.4	65	
OUTH Current	V _{TIP} = V* = 15 V (see fig. 5)	540	900	1040	
OUTL Current	V _{TIP} = V* = 15 V (see fig. 4)	750	-	1400	
Mirror Current	I _{MIRROR} = 1.0 mA, V _{OUTL} = 5.0 V (see fig. 8)	750	1245	1400	mA
Tip Current, No Load	V _{TIP-RING} = 20 V (see fig. 7)	0.25	1.410	1.8	
Ring Current, No Load	V _{TIP-RING} = - 20 V (see fig. 7)	- 0.25	- 1.41	- 1.8	
Input Threshold Voltage, Tip-ring	V* = 10 V (see fig. 6)	6.0	7.2	8.0	V
Clamp Voltage	I _{TP} = 20 mA (see fig. 9)	22.5	25.5	30	
	I _{TP} = - 20 mA (see fig. 9)	- 22.5	- 25.5	- 30	
	I _{TP} = 100 mA (see fig. 9)	-	3.6	5.5	
	I _{TP} = - 100 mA (see fig. 9)	-	- 3.6	- 5.5	

TEST CIRCUITS

Figure 2.

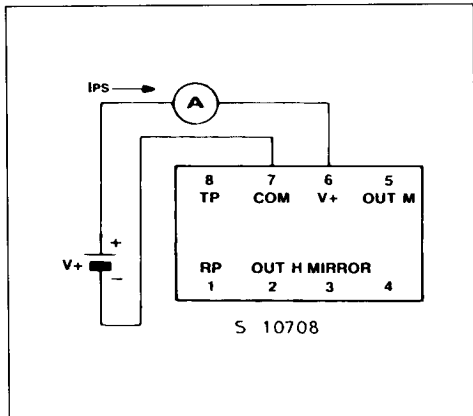

Figure 3.

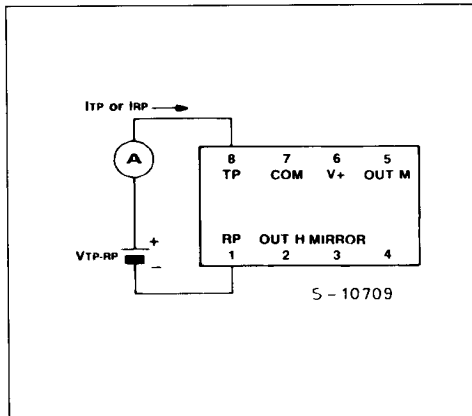

Figure 4.

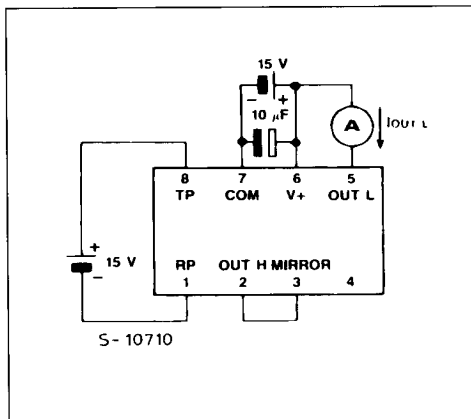

Figure 5.

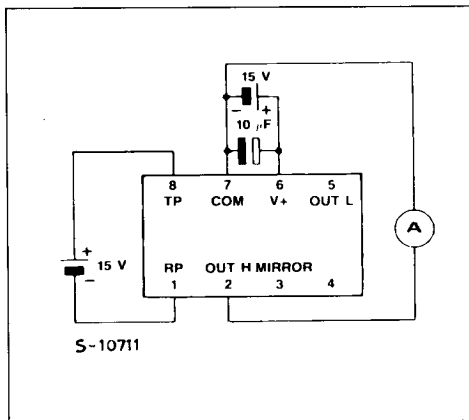

Figure 6

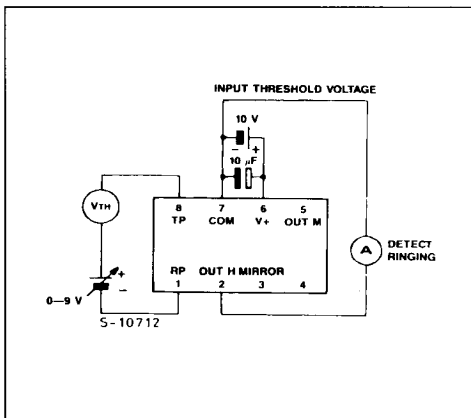

Figure 7

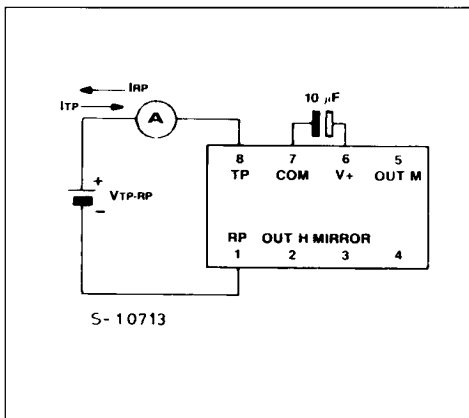

Figure 8

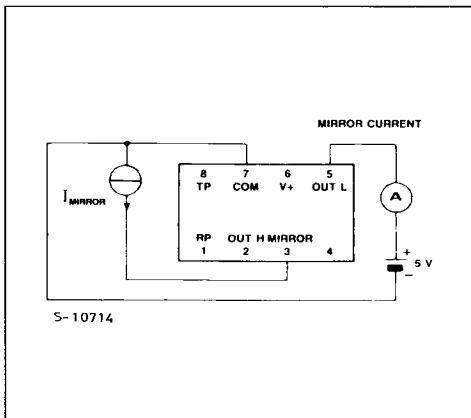
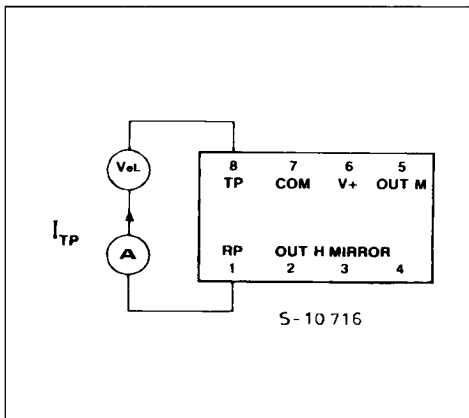

Figure 9



APPLICATION

The LB1006 detector derives its power by rectifying the AC ringing signal from the Tip-Ring pair of a telephone loop. It operates over widely varying waveforms (15 to 68 Hz at 40 to 150 VRMS). It uses this derived power to activate ringing detector logic, and then transfers most of this power to an output current driver. There is essentially no loading under non-ringing conditions. This device has two outputs, OUTH and OUTL. The OOUTH output is used to source output current when ringing is detected. The

OUTL output will sink output current when the OOUTH output is connected to the mirror input and when ringing is detected (see application diagram figure 11 and 12). The device does not have to depend upon power derived from the Tip-Ring inputs to become operational. Connecting an external voltage source to V+ will also allow the device to operate in what is described as "Stand Alone Applications".