

ADVANCE DATA

| TYPE | V _{DSS} | R _{DS(on)} | I _D |
|--------------|------------------|---------------------|----------------|
| TSD200N05F/V | 50 V | 0.006 Ω | 200 A |

- VERY HIGH DENSITY POWER MOS TECHNOLOGY
- HIGH CURRENT POWER MOS MODULE
- VERY LOW R_{th} JUNCTION TO CASE
- ISOLATED CASE (2500V RMS)
- EASY TO MOUNT
- LOW INTERNAL PARASITIC INDUCTANCE (TYPICALLY 5nH)

INDUSTRIAL APPLICATIONS:

- DC/DC & DC/AC CONVERTERS
- SMPS & UPS
- MOTOR CONTROL

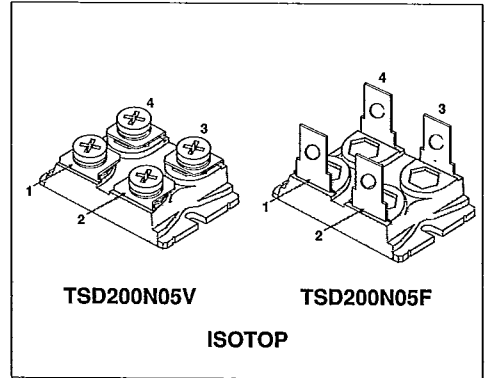

INTERNAL SCHEMATIC DIAGRAM

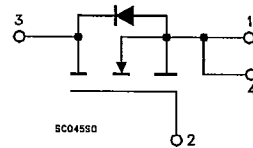

ABSOLUTE MAXIMUM RATINGS

| Symbol | Parameter | Value | Unit |
|---------------------|---|------------|------|
| V _{DS} | Drain-Source Voltage (V _{GS} = 0) | 50 | V |
| V _{DGR} | Drain-Gate Voltage (R _{GS} = 20 kΩ) | 50 | V |
| V _{GS} | Gate-Source Voltage | ± 20 | V |
| I _D | Drain Current (continuous) at T _c = 25 °C | 200 | A |
| I _D | Drain Current (continuous) at T _c = 100 °C | 126 | A |
| I _{DM} (*) | Drain Current (pulsed) | 600 | A |
| P _{tot} | Total Dissipation at T _c = 25 °C | 400 | W |
| | Derating Factor | 3.2 | W/°C |
| T _{stg} | Storage Temperature | -55 to 150 | °C |
| T _j | Max. Operating Junction Temperature | 150 | °C |
| V _{ISO} | Insulation Withstand Voltage (AC) | 2500 | V |

(*) Pulse width limited by safe operating area

30E D ■ 7929237 0030601 7 ■

THERMAL DATA S G S-THOMSON

| | | | | |
|----------------|---|-----|------|------|
| $R_{thj-case}$ | Thermal Resistance Junction-case | Max | 0.31 | °C/W |
| R_{thc-h} | Thermal Resistance Case-heatsink With Conductive Grease Applied | Max | 0.20 | °C/W |

ELECTRICAL CHARACTERISTICS ($T_{case} = 25\text{ °C}$ unless otherwise specified)

OFF

| Symbol | Parameter | Test Conditions | Min. | Typ. | Max. | Unit |
|---------------|--|---|------|------|-----------|---------------------|
| $V_{(BR)DSS}$ | Drain-Source Breakdown Voltage | $I_D = 2\text{ mA}$ $V_{GS} = 0$ | 50 | | | V |
| I_{DSS} | Zero Gate Voltage Drain Current ($V_{GS} = 0$) | $V_{DS} = \text{Max Rating}$ $V_{DS} = \text{Max Rating} \times 0.8$ $T_c = 125\text{ °C}$ | | | 400 2 | μA mA |
| I_{GSS} | Gate-Body Leakage Current ($V_{DS} = 0$) | $V_{GS} = \pm 20\text{ V}$ | | | ± 400 | nA |

ON (*)

| Symbol | Parameter | Test Conditions | Min. | Typ. | Max. | Unit |
|--------------|-----------------------------------|---|------|------|-------|----------|
| $V_{GS(th)}$ | Gate Threshold Voltage | $V_{DS} = V_{GS}$ $I_D = 2\text{ mA}$ | 2 | | 4 | V |
| $R_{DS(on)}$ | Static Drain-Source On Resistance | $V_{GS} = 10\text{ V}$ $I_D = 100\text{ A}$ | | | 0.006 | Ω |

DYNAMIC

| Symbol | Parameter | Test Conditions | Min. | Typ. | Max. | Unit |
|-----------|------------------------------|--|------|------|-------|------|
| g_{fs} | Forward Transconductance | $V_{DS} = 25\text{ V}$ $I_D = 100\text{ A}$ | 20 | | | mho |
| C_{iss} | Input Capacitance | $V_{DS} = 25\text{ V}$ $f = 1\text{ MHz}$ $V_{GS} = 0$ | | | 12000 | pF |
| C_{oss} | Output Capacitance | | | | 4000 | pF |
| C_{rss} | Reverse Transfer Capacitance | | | | 720 | pF |

SWITCHING (INDUCTIVE LOAD)

| Symbol | Parameter | Test Conditions | Min. | Typ. | Max. | Unit |
|----------------|-----------------------|---|------|------|------|------|
| $t_{d(on)}$ | Turn-on Time | $V_{DD} = 40\text{ V}$ $I_D = 100\text{ A}$ $R_{GS} = 25\ \Omega$ $V_{GS} = 10\text{ V}$ | | 200 | | ns |
| $(di/dt)_{on}$ | Turn-on Current Slope | | | | | ns |
| $t_{d(off)}$ | Turn-off Delay Time | | | 1500 | | ns |
| t_f | Fall Time | | | 600 | | ns |

SOURCE DRAIN DIODE

| Symbol | Parameter | Test Conditions | Min. | Typ. | Max. | Unit |
|--------------------|-------------------------------|--|------|------|------|------|
| I_{SD} | Source-Drain Current | | | | 200 | A |
| $I_{SDM}(\bullet)$ | Source-Drain Current (pulsed) | | | | 600 | A |
| V_{SD} | Forward On Voltage | $I_{SD} = 200\text{ A}$ $V_{GS} = 0$ | | | 2 | V |
| t_{rr} | Reverse Recovery Time | $I_{SD} = 200\text{ A}$ $di/dt = 100\text{ A}/\mu\text{s}$ | | 80 | | ns |

(*) Pulsed: Pulse duration = 300 μs , duty cycle 1.5 %

(\bullet) Pulse width limited by safe operating area

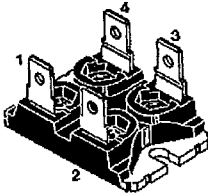

ISOTOP
Fast-on version
sales types with the suffix F

MECHANICAL DATA

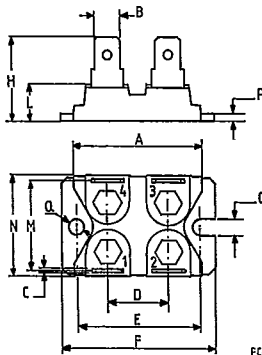

FC-9309

| | DIMENSIONS | | | |
|---|------------|------|--------|-------|
| | mm | | Inches | |
| | min. | max | min. | max |
| A | 31.5 | 31.7 | 1.240 | 1.248 |
| B | 6.2 | 6.4 | 0.244 | 0.252 |
| C | 0.75 | 0.85 | 0.029 | 0.033 |
| D | 14.9 | 15.1 | 0.586 | 0.590 |
| E | 30.1 | 30.3 | 1.185 | 1.193 |
| F | 38 | 38.2 | 1.496 | 1.503 |
| G | 4 | - | 0.157 | - |
| H | 20.3 | 20.7 | 0.799 | 0.815 |
| L | 8.9 | 9.1 | 0.350 | 0.358 |
| M | 22.4 | 23 | 0.881 | 0.905 |
| N | 25.2 | 25.4 | 0.992 | 1.000 |
| P | 1.95 | 2.05 | 0.076 | 0.080 |
| Q | 4 | - | 0.157 | - |

PIN CONNECTIONS

MOSFET

pin 1: Source pin 2: Gate
pin 3: Drain pin 4: Source sensings

DARLINGTON

pin 1: Emitter pin 2: Base1
pin 3: Collector pin 4: Base 2

TRANSISTOR

pin 1: Emitter pin 2: Base
pin 3: Collector pin 4: Emitter sensing

Torque: Mounting $1.3 \pm 0.2 \text{ N} \cdot \text{m}$ (max)

Weight: Package 25.5 g

Note: The mechanical data are the same for the 3 pin version (4th pin missing)

S G S-THOMSON

T-91-20

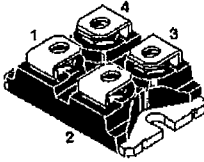

ISOTOP
Screw version
sales types with the suffix V

MECHANICAL DATA

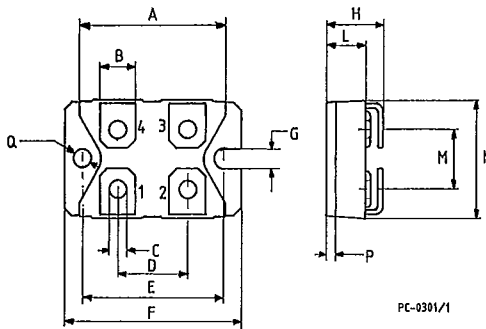

PC-0301/1

| | DIMENSIONS | | | |
|---|------------|------|--------|-------|
| | mm | | Inches | |
| | min. | max | min. | max |
| A | 31.5 | 31.7 | 1.240 | 1.248 |
| B | 7.8 | 8.2 | 0.307 | 0.322 |
| C | 4.1 | 4.3 | 0.161 | 0.169 |
| D | 14.9 | 15.1 | 0.586 | 0.590 |
| E | 30.1 | 30.3 | 1.185 | 1.193 |
| F | 38 | 38.2 | 1.496 | 1.503 |
| G | 4 | - | 0.157 | - |
| H | 11.8 | 12.2 | 0.464 | 0.480 |
| L | 8.9 | 9.1 | 0.350 | 0.358 |
| M | 12.6 | 12.8 | 0.496 | 0.503 |
| N | 25.2 | 25.4 | 0.992 | 1.000 |
| P | 1.95 | 2.05 | 0.076 | 0.080 |
| Q | 4 | - | 0.157 | - |

PIN CONNECTIONS

MOSFET

pin 1: Source pin 2: Gate
pin 3: Drain pin 4: Source sensings

DARLINGTON

pin 1: Emitter pin 2: Base1
pin 3: Collector pin 4: Base 2

TRANSISTOR

pin 1: Emitter pin 2: Base
pin 3: Collector pin 4: Emitter sensing

Torque: Terminal $1.3 \pm 0.2 \text{ N} \cdot \text{m}$ (max)
Mounting $1.3 \pm 0.2 \text{ N} \cdot \text{m}$ (max)

Weight: Package 29 g
4 Screws: 7.5 g

Note: The mechanical data are the same for the 3 pin version
(4th pin missing)

SGS-THOMSON

T-91-20

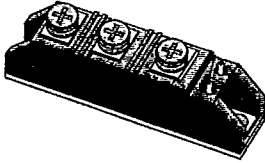

TRANSPACK (TO-240)

MECHANICAL DATA

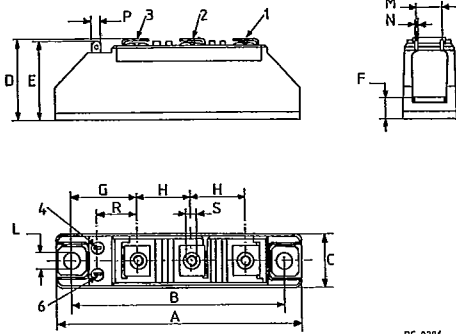

PC-0236

| | DIMENSIONS | | | |
|---|------------|-------|------------|-------|
| | mm | | Inches | |
| | min. | max | min. | max |
| A | 91.5 | 92.5 | 3.602 | 3.641 |
| B | 79.75 | 80.25 | 3.140 | 3.160 |
| C | 19.5 | 20.55 | 0.767 | 0.809 |
| D | 29.00 | 31.00 | 1.141 | 1.220 |
| E | 28.8 | 30 | 1.134 | 1.181 |
| F | 8.5 typ. | | 0.334 typ. | |
| G | 24.4 typ. | | 0.960 typ. | |
| H | 19.5 | 20.5 | 0.767 | 0.807 |
| L | 6.2 typ. | | 0.244 typ. | |
| M | 8.95 | 11.05 | 0.352 | 0.435 |
| N | 0.78 | 0.84 | 0.030 | 0.033 |
| P | 2.72 | 2.87 | 0.107 | 0.113 |
| R | 14 | - | 0.551 | - |
| S | M5 | | | |

Torque: Terminal $2.2 \pm 0.5 \text{ N} \cdot \text{m}$ (max)
 Mounting $3.5 \pm 0.5 \text{ N} \cdot \text{m}$ (max)

Weight: Package 110 g
 Accessory 21 g

Note: The mechanical data are the same for the 2 power pin version (either pin 1 or pin 2 missing)