

## PM-139/PM-139A/PM-239

### FEATURES

- Single or Dual Supply Operation
- Input Voltage Range Includes Ground
- Low Power Consumption (2mW/Comparator)
- Low Input Bias Current ..... 25nA
- Low Input Offset Current ..... ±5nA
- Low Offset Voltage ..... ±2mV
- Low Output Saturation Voltage (250mV @ 4mA)
- Logic Outputs Compatible with TTL, DTL, ECL, MOS, and CMOS
- Directly Replaces LM139 and LM139A Comparators
- Available in Die Form

### ORDERING INFORMATION †

+25°C V <sub>OS</sub> (mV)	PACKAGE		OPERATING TEMPERATURE RANGE
	DIP 14-PIN	LCC 20-CONTACT	
±2*	PM139AY*	PM139ARC/883	MIL
±5*	PM139Y*	—	MIL
±5	PM239P	—	XIND

\* For devices processed in total compliance to MIL-STD-883, add /883 after part number. Consult factory for 883 data sheet.

† Burn-in is available on commercial and industrial temperature range parts in CerDIP, plastic DIP, and TO-can packages.

### JAN ORDERING INFORMATION

JAN PART NUMBER	DESCRIPTION
JM38510/11201BCA	PM139Y5/38510 LEVEL B
JM38510/11201BCB	PM139Y2/38510 LEVEL B
JM38510/11201SCA*	PM139Y5/38510 LEVEL S

Table above is for MIL-M-38510 processing. Refer to 11201 slash sheet for electrical processing parameters.

\* Undergoing Part I qualification. Consult ADI for availability.

### SIMPLIFIED SCHEMATIC (ONE COMPARATOR)

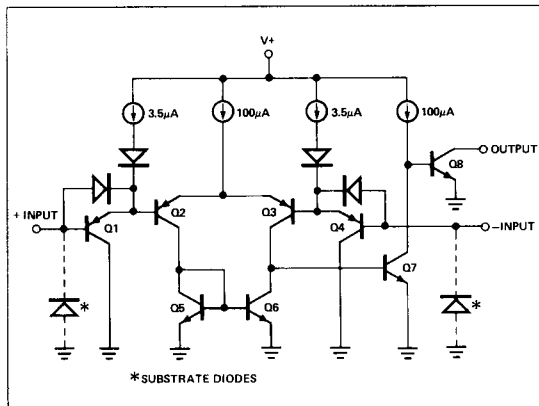

### GENERAL DESCRIPTION

The PM-139 has four independent voltage comparators, each with precision DC specifications. Low offset voltage, bias current, power consumption and output saturation voltage are offered in a design that features single power supply operation. The input voltage range includes ground for convenient single supply operation. The 2mA power supply current, independent of supply voltage – coupled with the single supply operation, makes this comparator ideal for low power applications. Open collector outputs allow maximum applications flexibility.

3

### PIN CONNECTIONS

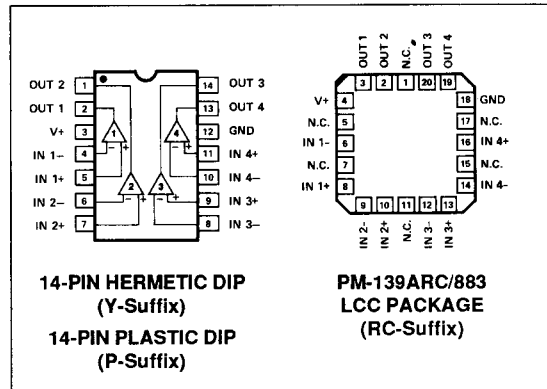

### ABSOLUTE MAXIMUM RATINGS

Supply Voltage, V <sub>+</sub>	36V or ±18V
Differential Input Voltage	36V
Input Voltage	-0.3V to +36V
Derate Above 100°C	10mW/°C
Output Short-Circuit to Ground	Continuous
Input Current (V <sub>IN</sub> < -0.3V)	50mA
Operating Temperature Range	
PM-139A/139/139ARC	-55°C to +125°C
PM-239P	-40°C to +85°C
Storage Temperature Range	-65°C to +150°C
Lead Temperature (Soldering, 60 sec)	300°C
Junction Temperature	+150°C

PACKAGE TYPE	θ <sub>JA</sub> (Note 1)	θ <sub>JC</sub>	UNITS
14-Pin Hermetic DIP (Y)	110	26	°C/W
14-Pin Plastic DIP (P)	90	47	°C/W

#### NOTE:

1. θ<sub>JA</sub> is specified for worst case mounting conditions, i.e., θ<sub>JA</sub> is specified for device in socket for CerDIP and P-DIP packages.

# PM-139/PM-139A/PM-239

**ELECTRICAL CHARACTERISTICS** at  $V_+ = +5V$ ,  $T_A = 25^\circ C$ , unless otherwise noted.

PARAMETER	SYMBOL	CONDITIONS	PM-139A			PM-139/239			UNITS
			MIN	TYP	MAX	MIN	TYP	MAX	
Input Offset Voltage	$V_{OS}$	(Note 1)	—	1	2	—	2	5	mV
Input Bias Current	$I_B$	$I_{IN}(+)$ or $I_{IN}(-)$ with Output in Linear Range	—	25	100	—	25	100	nA
Input Offset Current	$I_{OS}$	$I_{IN}(+)$ or $I_{IN}(-)$	—	3	25	—	3	25	nA
Input Common-Mode Voltage Range	CMVR	(Notes 2, 5, 6)	0	—	3.5	0	—	3.5	V
Supply Current	$I_S$	$R_L = \infty$ on all Comparators $V_+ = 30V$	—	0.8	2	—	0.8	2	mA
Voltage Gain	$A_{VO}$	$R_L \geq 15k\Omega$ , $V_+ = 15V$ (To support large $V_O$ swing) (Note 5)	50	200	—	50	200	—	V/mV
Large-Signal Response Time	$t_r$	$V_{IN} =$ TTL Logic Swing, $V_{REF} = 1.4V$ , $V_{RL} = 5V$ , $R_L = 5.1k\Omega$ , (Note 4)	—	300	—	—	300	—	ns
Response Time	$t_r$	$V_{RL} = 5V$ , $R_L = 5.1k\Omega$ (Notes 3, 4)	—	1.3	—	—	1.3	—	$\mu s$
Output Sink Current	$I_{SINK}$	$V_{IN}(-) \geq 1V$ , $V_{IN}(+) = 0$ , $V_O \leq 1.5V$	6	16	—	6	16	—	mA
Saturation Voltage	$V_{OL}$	$V_{IN}(-) \geq 1V$ , $V_{IN}(+) = 0$ , $I_{SINK} \leq 4mA$	—	250	400	—	250	400	mV
Output Leakage Current	$I_{LEAK}$	$V_{IN}(+) \geq 1V$ , $V_{IN}(-) = 0$ , $V_O = 30V$	—	0.1	—	—	0.1	—	nA

**ELECTRICAL CHARACTERISTICS** at  $V_+ = +5V$ ,  $-55^\circ C \leq T_A \leq +125^\circ C$  for PM-139A and PM-139,  $-40^\circ C \leq T_A \leq +85^\circ C$  for PM-239, unless otherwise noted.

PARAMETER	SYMBOL	CONDITIONS	PM-139A			PM-139/239			UNITS
			MIN	TYP	MAX	MIN	TYP	MAX	
Input Offset Voltage	$V_{OS}$	(Note 1)	—	—	4	—	—	9	mV
Input Offset Current	$I_{OS}$	$I_{IN}(+)$ or $I_{IN}(-)$	—	—	100	—	—	100	nA
Input Bias Current	$I_B$	$I_{IN}(+)$ OR $I_{IN}(-)$ with Output in Linear Range	—	—	300	—	—	300	nA
Input Common-Mode Voltage Range	CMVR	(Notes 3, 5)	0	—	$V_+ - 2$	0	—	$V_+ - 2$	V
Saturation Voltage	$V_{OL}$	$V_{IN}(-) \geq 1V$ , $V_{IN}(+) = 0$ , $I_{SINK} \leq 4mA$	—	—	700	—	—	700	mV
Output Leakage Current	$I_{LEAK}$	$V_{IN}(+) \geq 1V$ , $V_{IN}(-) = 0$ , $V_O = 30V$	—	—	1	—	—	1	$\mu A$
Differential Input Voltage		Keep All $V_{INs} \geq 0V$	—	—	36	—	—	36	V

**NOTES:**

- At output switch point,  $V_O = 1.4V$ ,  $R_S = 0\Omega$  with  $V_+$  from 5V, and over the full input common-mode range (0V to  $V_+ - 1.5V$ ).
- The input common-mode voltage or either input voltage signal should not be allowed to go negative by more than 0.3V. The upper end of the common-mode voltage range is  $V_+ - 1.5V$ , but either or both inputs can go to +30V without damage.
- The response time specified is for a 100mV input step with 5mV overdrive. For larger overdrive signals 300ns can be obtained. See characteristics section.
- Sample tested.
- Guaranteed by design.
- Positive CMVR limit equals  $V_+ - 1.5V$  for supply voltages other than 5V.

DICE CHARACTERISTICS

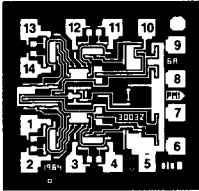

DIE SIZE 0.051 × 0.048 inch, 2448 sq. mils  
(1.295 × 1.220 mm, 1.58 sq. mm)

- |                           |                            |
|---------------------------|----------------------------|
| 1. OUTPUT (2)             | 8. INVERTING INPUT (3)     |
| 2. OUTPUT (1)             | 9. NONINVERTING INPUT (3)  |
| 3. POSITIVE SUPPLY        | 10. INVERTING INPUT (4)    |
| 4. INVERTING INPUT (1)    | 11. NONINVERTING INPUT (4) |
| 5. NONINVERTING INPUT (1) | 12. GROUND (SUBSTRATE)     |
| 6. INVERTING INPUT (2)    | 13. OUTPUT (4)             |
| 7. NONINVERTING INPUT (2) | 14. OUTPUT (3)             |

WAFER TEST LIMITS at  $V_+ = +5V$ ,  $T_A = 25^\circ C$ , unless otherwise noted.

PARAMETER	SYMBOL	CONDITIONS	PM-139N LIMIT	UNITS
Input Offset Voltage	$V_{OS}$	$R_S = 0\Omega$ , $R_L = 5.1k\Omega$ $V_O = 1.4V$ , (Note 1)	2	mV MAX
Input Offset Current	$I_{OS}$	$I_{IN(+)} - I_{IN(-)}$ $R_L = 5.1k\Omega$ $V_O = 1.4V$	25	nA MAX
Input Bias Current	$I_B$	$I_{IN(+)}$ or $I_{IN(-)}$ , (Note 1)	100	nA MAX
Voltage Gain	$A_V$	$R_L \geq 15k\Omega$ , $V_+ = 15V$ , (Note 3)	50	V/mV MIN
Input Voltage Range	CMVR	(Notes 2, 3)	$V_+ - 1.5$	V MAX
Common-Mode Rejection Ratio	CMRR	(Note 4)	60.5	dB MIN
Power Supply Rejection Ratio	PSRR	$V_+ = 5V$ to $+18V$	60.5	dB MIN
Saturation Voltage	$V_{OL}$	$V_{IN(-)} \geq 1V$ , $V_{IN(+)} = 0$ , $I_{SINK} \leq 4mA$	400	mV MAX
Output Sink Current	$I_{SINK}$	$V_{IN(-)} \geq 1V$ , $V_{IN(+)} = 0$ , $V_O \leq 1.5V$	6	mA MIN
Output Leakage Current	$I_{LEAK}$	$V_{IN(+)} \geq 1V$ , $V_{IN(-)} = 0$ , $V_O = 30V$	500	nA MAX
Supply Current	$I_+$	$R_L = \infty$ , All Comps $V_+ = 30V$	2	mA MAX

NOTES:

Electrical tests are performed at wafer probe to the limits shown. Due to variations in assembly methods and normal yield loss, yield after packaging is not guaranteed for standard product dice. Consult factory to negotiate specifications based on dice lot qualification through sample lot assembly and testing.

TYPICAL ELECTRICAL CHARACTERISTICS at  $V_+ = +5V$ , unless otherwise noted.

PARAMETER	SYMBOL	CONDITIONS	PM-139N TYPICAL	UNITS
Large-Signal Response Time	$t_r$	$V_{IN} =$ TTL Logic Swing $V_{REF} = 1.4V$ , (Note 5) $V_{RL} = 5V$ , $R_L = 5.1k\Omega$	600	ns
Small-Signal Response Time	$t_r$	$V_{IN} = 100mV$ Step, (Note 5) 5mV Overdrive $V_{RL} = 5V$ , $R_L = 5.1k\Omega$	1.3	$\mu s$

NOTES:

- |  |  |
|--|--|
| 1. At output switch point, $V_O = 1.4V$ , $R_S = 0\Omega$ with $V_+$ from 5V; and over the full input common-mode range (0V to $V_+ - 1.5V$ ). | common-mode voltage range is $V_+ - 1.5V$ , but either or both inputs can go to $+30V$ without damage. |
| 2. The input common-mode voltage or either input signal voltage should not be allowed to go negative by more than 0.3V. The upper end of the   | 3. Guaranteed by design.   |
|  | 4. $R_L \geq 15k\Omega$ . $V_{CM} = 1.5V$ to $13.5V$ , $V_+ = 15V$ .                                   |
|  | 5. Sample tested.  |

# PM-139/PM-139A/PM-239

## TYPICAL PERFORMANCE CHARACTERISTICS

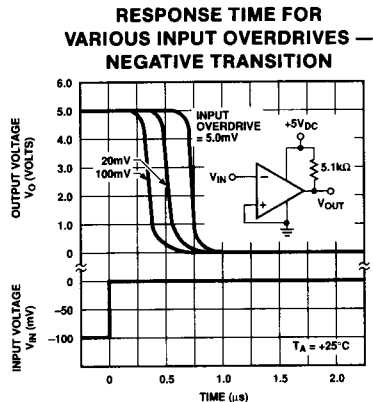
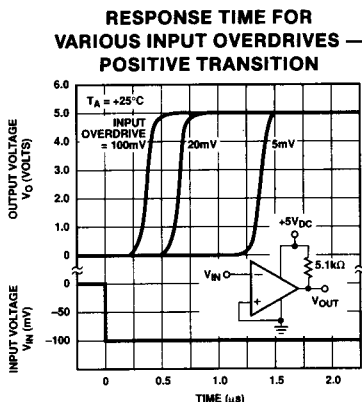
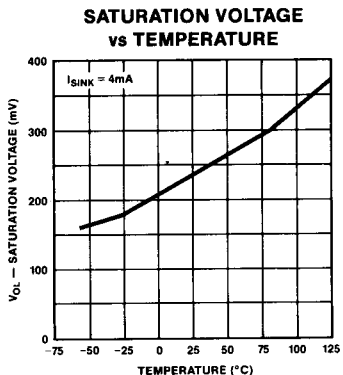
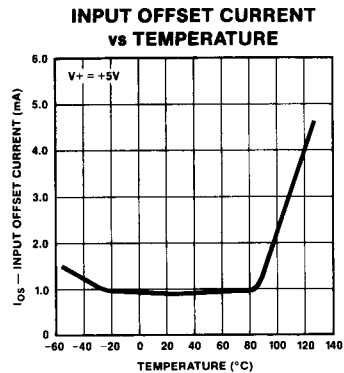
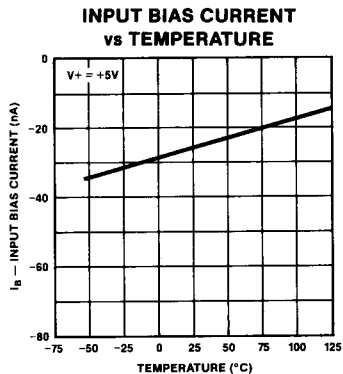
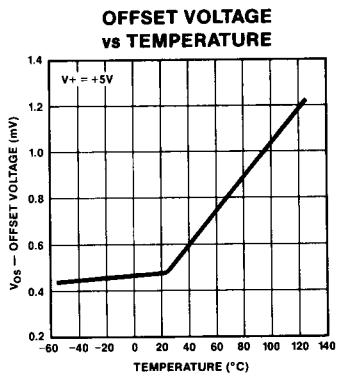

## TYPICAL INTERFACE

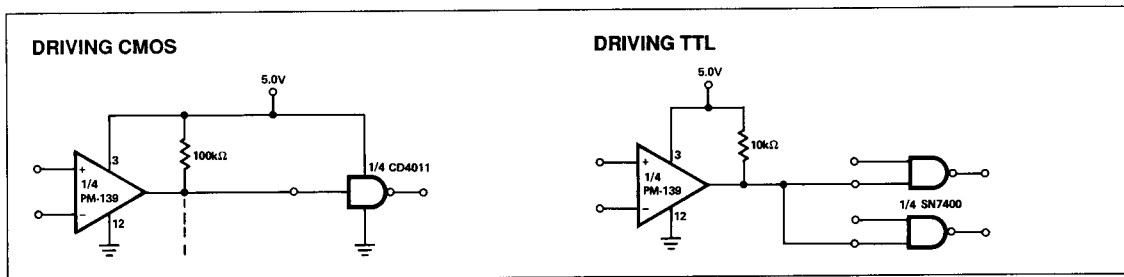

TYPICAL APPLICATIONS

OR GATE

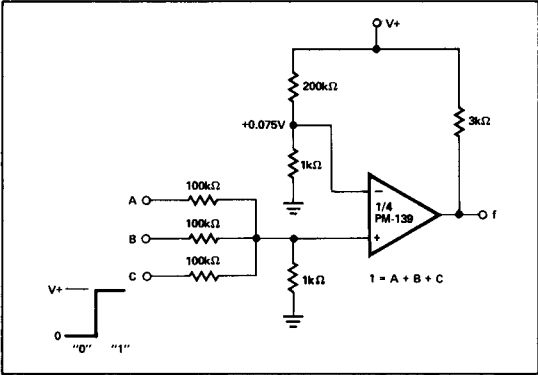

AND GATE

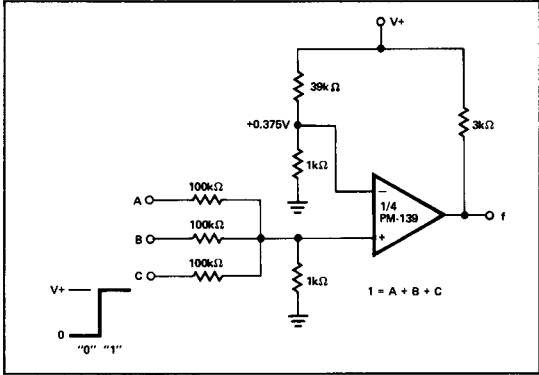

3

TIME DELAY GENERATOR

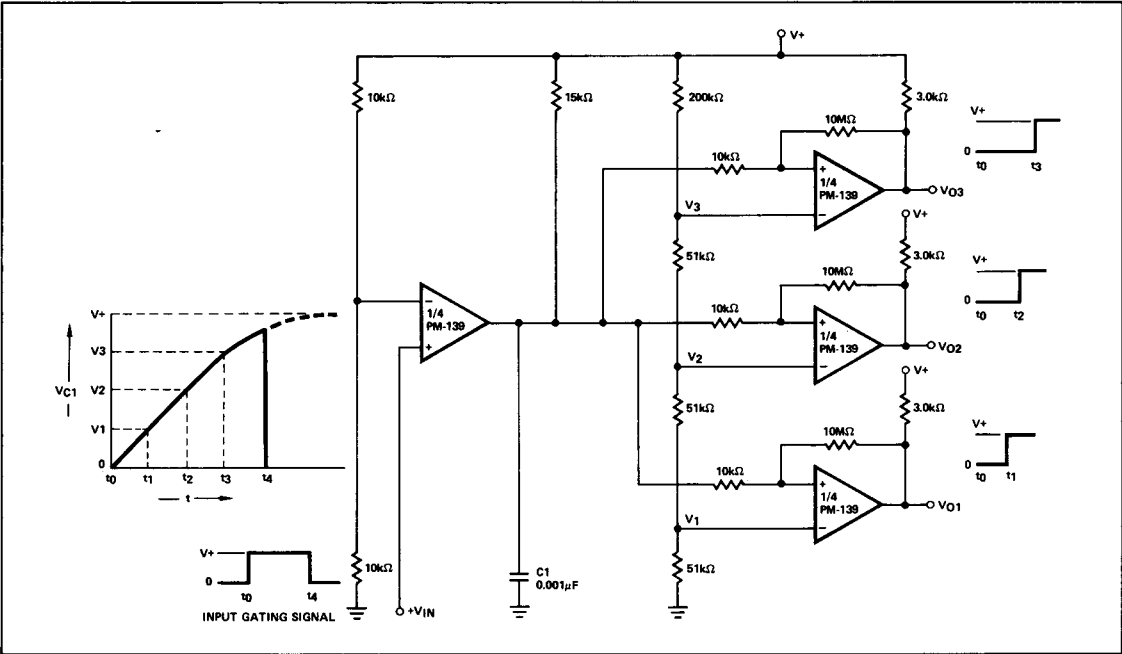

# PM-139/PM-139A/PM-239

## TYPICAL APPLICATIONS

### ONE-SHOT MULTIVIBRATOR WITH INPUT LOCK-OUT

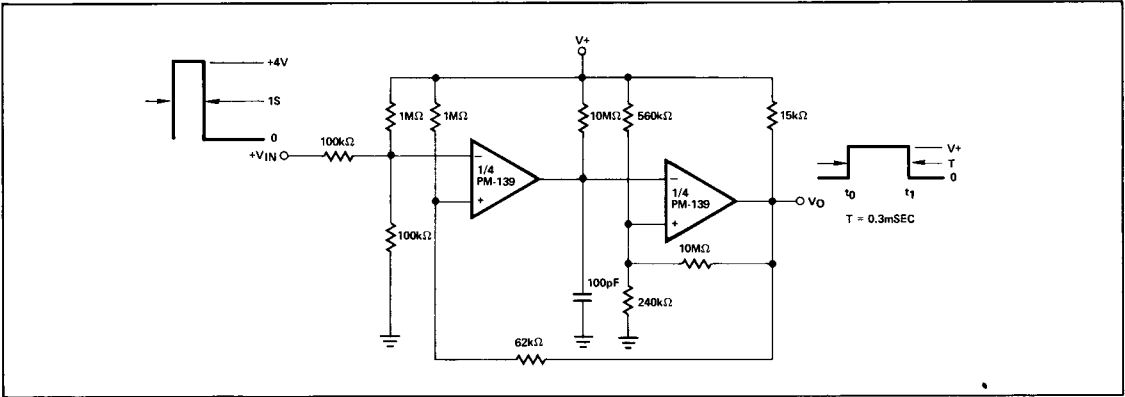

### ONE-SHOT MULTIVIBRATOR

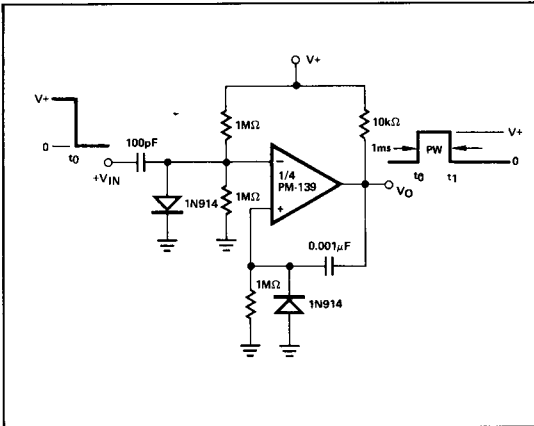

### BURN-IN CIRCUIT

