

EXAMINED BY: <i>David Chang</i>	EMERGING DISPLAY TECHNOLOGIES CORPORATION	FILE NO . CAS-10011
APPROVED BY: <i>Messrs Chen</i>		ISSUE : SEP.19,2001
		TOTAL PAGE : 9
		VERSION : 4

CUSTOMER	ACCEPTANCE	SPECIFICATIONS
----------	------------	----------------

MODEL NO. :

12A03(LED TYPES)

FOR MESSRS :

CUSTOMER'S APPROVAL

DATE :

BY :

EMERGING DISPLAY
TECHNOLOGIES CORPORATION

MODEL NO . 12A03(LED TYPES)	VERSION 4
--------------------------------	--------------

RECORDS OF REVISION	DOC . FIRST ISSUE OCT.22,1997
---------------------	----------------------------------

DATE	REVISED PAGE NO.	SUMMARY
NOV.11,1998	2	3.2 ENVIRONMENTAL ABSOLUTE MAXIMUM RATINGS AMBIENT TEMPERATURE : OPERATING FOR W.T. : 60°C MAX.→70°C MAX. STORAGE FOR W.T. : 70°C MAX.→80°C MAX.
	3	4. ELECTRICAL CHARACTERISTICS RECOMMENDED LCD DRIVING VOLTAGE : VDD-VO W.T. : Ta=60°C →Ta=70°C
	5	6. OPTICAL CHARACTERISTICS RESPONSE TIME W.T. : Ta=60°C →Ta=70°C
SEP.09,1999	1~3,5	THE ENTIRE PAGES REVISED CHANGE VERSION
SEP.19,2001	3	4. ELECTRICAL CHARACTERISTICS VF : 4.0 → 4.2 , IF : 84 → 120 , IR : 120 (TYP.)μA → 0.2 (MAX.) mA

TABLE OF CONTENTS

NO.	ITEM	PAGE
=====		
1.	GENERAL SPECIFICATIONS -----	1
2.	MECHANICAL SPECIFICATIONS -----	1
3.	ABSOLUTE MAXIMUM RATINGS -----	2
4.	ELECTRICAL CHARACTERISTICS -----	3
5.	TIMING CHARACTERISTICS -----	4
6.	OPTICAL CHARACTERISTICS -----	5
7.	OUTLINE DIMENSION -----	6
8.	DETAIL DRAWING OF DOT MATRIX -----	7
9.	POWER SUPPLY -----	7
10.	BLOCK DIAGRAM -----	8
11.	INTERFACE SIGNALS -----	9

NUMBERING SYSTEM

Polarizer Mode	Backlight	Code value
Transflective	LED	L

Backlight Color	Code Value
Yellow-Green	Y

E	W	1	2	A	0	3	G	L	Y
---	---	---	---	---	---	---	---	---	---

LCD type + LCD color	Code Value
STN + Yellow-Green	Y
STN + Gray	G
FSTN + White	F

1. GENERAL SPECIFICATIONS

1.1 GENERAL SPECIFICATIONS

PLEASE REFER TO :

CUSTOMER ACCEPTANCE STANDARD SPECIFICATIONS :

E U - 0 0 2 A

1.2 APPLICATION NOTES FOR CONTROLLER / DRIVER :

PLEASE REFER TO :

CUSTOMER ACCEPTANCE STANDARD SPECIFICATIONS :

E U - S E D 1 5 2 0 D 0 A

1.3 THIS INDIVIDUAL SPECIFICATIONS IS PRIOR TO GENERAL SPECIFICATIONS .

2. MECHANICAL SPECIFICATIONS

- | | | |
|--------------------|-------|----------------------------------|
| (1) NUMBER OF DOTS | ----- | 122 * 32 DOTS |
| (2) MODULE SIZE | ----- | 69.2W * 31.75H * 11.0D (MAX.) mm |
| (3) EFFECTIVE AREA | ----- | 57.2W * 17.2H mm |
| (4) ACTIVE AREA | ----- | 52.41W * 13.71H mm |
| (5) DOT SIZE | ----- | 0.38W * 0.38H mm |
| (6) DOT PITCH | ----- | 0.43W * 0.43H mm |
| (7) LCD TYPE * | | |
| (8) DRIVING METHOD | ----- | 1 / 32 DUTY MULTIPLEX DRIVER |
| (9) BACK LIGHT * | | |

* PLEASE REFER TO NUMBERING SYSTEM

3. ABSOLUTE MAXIMUM RATINGS

3.1 ELECTRICAL ABSOLUTE MAXIMUM RATINGS. (AT Ta = 25 °C)

PARAMETER	SYMBOL	MIN .	MAX .	UNIT	REMARK
SUPPLY VOLTAGE FOR LOGIC	VDD – VSS	0	8.0	V	
INPUT VOLTAGE	VI	VSS	VDD	V	
STATIC ELECTRICITY	—	—	100	V	NOTE (1)
LED FORWARD CURRENT	IF	—	360	mA	
LED REVERSE VOLTAGE	VR	—	8	V	

NOTE (1) : TEST METHOD AND CONDITIONS :
AFTER CHARGING UP 200 PF CAPACITOR BY STATED VOLTAGE ,
THE CAPACITOR IS CONNECTED WITH INTERFACE PINS OF THE
MODULE .

3.2 ENVIRONMENTAL ABSOLUTE MAXIMUM RATINGS .

I T E M	OPERATING		STORAGE		REMARK
	MIN .	MAX .	MIN .	MAX .	
AMBIENT TEMPERATURE	- 20 °C	70 °C	- 30 °C	80 °C	NOTE (2) , (3)
HUMIDITY	—	90 % RH	—	90 % RH	WITHOUT CONDENSATION
VIBRATION	—	4.9 m/s ² (0.5 G)	—	19.6 m/s ² (2 G)	
SHOCK	—	29.4 m/s ² (3 G)	—	490.0 m/s ² (50 G)	XYZ DIRECTIONS
CORROSIVE GAS	NOT ACCEPTABLE		NOT ACCEPTABLE		

NOTE (2) : Ta AT -30°C : 48HR MAX .
80°C : 168HR MAX .

NOTE (3) : BACKGROUND COLOR CHANGES SLIGHTLY DEPENDING ON AMBIENT
TEMPERATURE THIS PHENOMENON IS REVERSIBLE .

4. ELECTRICAL CHARACTERISTICS

PARAMETERM		SYMBOL	CONDITION	MIN .	TYP .	MAX .	UNIT
POWER SUPPLY VOLTAGE	RECOMMENDED	VDD – VSS	—	4.5	5.0	5.5	V
	ALLOWABLE	VDD – VSS	—	2.4	—	7.0	V
HIGH LEVEL INPUT VOLTAGE	FOR TTL	VIHT	NOTE (1)	2.0	—	VDD	V
	FOR CMOS	VIHC	NOTE (2)	4.0	—	VDD	V
LOW LEVEL INPUT VOLTAGE	FOR TTL	VILT	NOTE (1)	0	—	0.8	V
	FOR CMOS	VILC	NOTE (2)	0	—	1.0	V
HIGH LEVEL OUTPUT VOLTAGE	FOR TTL	VOHT	IOH= -3.0 mA NOTE (3)	2.4	—	—	V
LOW LEVEL OUTPUT VOLTAGE	FOR TTL	VOLT	IOL= 3.0 mA NOTE (3)	—	—	0.4	V
POWER SUPPLY CURRENT (INCLUDE DC TO DC CONVERTER)		IDD	VDD-VSS=5V	—	2.5	—	mA
LCD DISPLAY DUTY RATIO		DUTY	—	—	32	—	—
OSCILLATION FREQUENCY	f OSC		VDD = 5.0 V RF = 1.0MΩ	15	18	21	kHZ
			VDD = 3.0 V RF = 1.0MΩ	11	16	21	kHZ
RESET TIME		t R	—	1.0	—	1000	uS
RECOMMENDED LCD DRIVING VOLTAGE	VDD – VO ∅ = 10 ° θ = 0 °		Ta = - 20 °C	—	5.5	—	V
			Ta = 25 °C	—	5.5	—	V
			Ta = 70 °C	—	5.2	—	V
LED FORWARD VOLTAGE		VF	—	—	4.2	—	V
LED FORWARD CURRENT		IF	—	—	120	—	mA
LED REVERSE CURRENT		IR	—	—	—	0.2	mA

NOTE (1) : APPLIED TO TERMINALS A0 , DB0 ~ DB7 , E , R / W .

NOTE (2) : APPLIED TO TERMINALS RES .

NOTE (3) : APPLIED TO TERMINALS DB0 ~ DB7

NOTE (4) : RECOMMENDED LCD DRIVING VOLTGE MAY FLUCTUATE ABOUT ±0.5V BY EACH MODULE .

5. TIMING CHARACTERISTICS
MPU BUS READ/WRITE (68-FAMILY MPU)

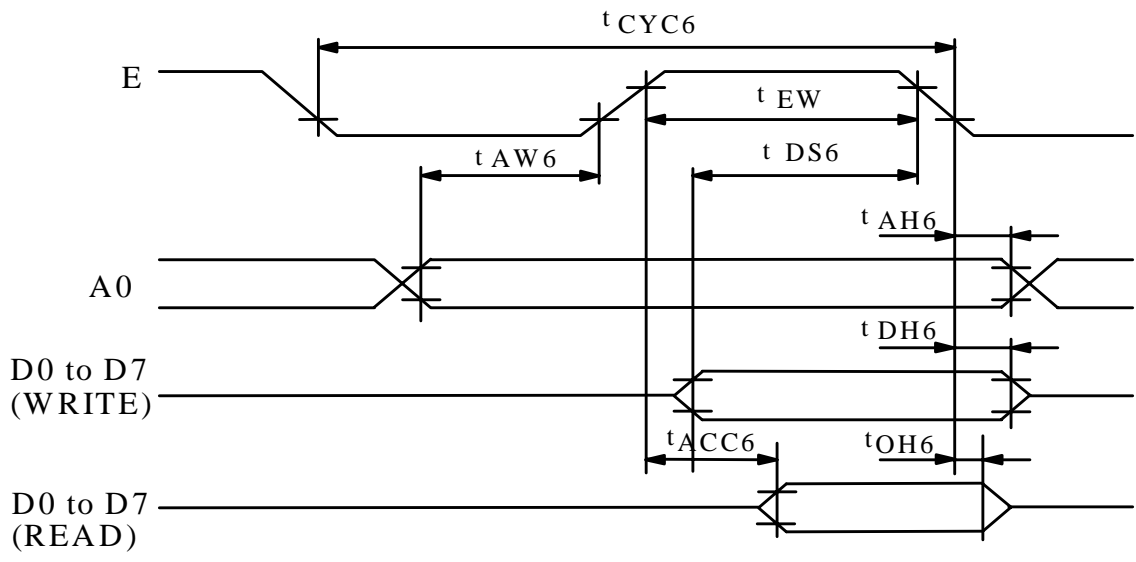

PARAMETER	SYMBOL	CONDITION	RATING		UNIT	SIGNAL
SYSTEM CYCLE TIME	t_{CYC6}		1000	—	ns	A0
ADDRESS SETUP TIME	t_{AW6}		20	—	ns	
ADDRESS HOLD TIME	t_{AH6}		10	—	ns	
DATA SETUP TIME	t_{DS6}		80	—	ns	D0 TOD7
DATA HOLD TIME	t_{DH6}		10	—	ns	
OUTPUT DISABLE TIME	t_{OH6}	CL=100PF	10	60	ns	
ACCESS TIME	t_{ACC6}		—	90	ns	
ENABLE	READ	t_{EW}	100	—	ns	E
PULSEWIDTH	WRITE		8	—	ns	

- NOTES:
- t_{CYC6} IS THE CYCLE TIME OF CS. E=H,NOT THE CYCLE TIME OF E.
 - INCREASE PARAMETER VALUES BY 200% THEN VDD=3.0V.
 - ALL INPUTS MUST HAVE A RISE AND FALL TIME OF LESS THAN 15ns.

6. OPTICAL CHARACTERISTICS

Ta = 25 °C

VDD = 5.0 V

VDD - V0 = 5.5 V

I T E M		SYMBOL	CONDITION	MIN.	TYP.	MAX.	UNIT	NOTE
VIEWING AREA	STN	∅ 2 - ∅ 1	K ≥ 1.4	40	—	—	deg.	1
	FSTN			50	—	—	deg.	1
CONTRAST RATIO	STN	K	∅ = 10° θ = 0°	—	5	—	—	1
	FSTN			5	—	—	—	1
REPOSE TIME	tr (rise)	∅ = 10° θ = 0°	Ta = -20°C	—	5538	—	ms	1
			Ta = 25°C	—	228	—		
			Ta = 70°C	—	104	—		
	tf (fall)		Ta = -20°C	—	2316	—		
			Ta = 25°C	—	174	—		
			Ta = 70°C	—	85	—		
THE BRIGHTNESS OF BACK-LIGHT	L	IF = 120 mA	30	50	—	cd/m ²	1	
PEAK EMISSION WAVELENGTH	λP	IF = 120 mA	—	570	—	nm	1	

NOTE (1) : PLEASE REFER TO :

CUSTOMER ACCEPTANCE STANDARD SPECIFICATIONS.

EU-002A

7. OUTLINE DIMENSION

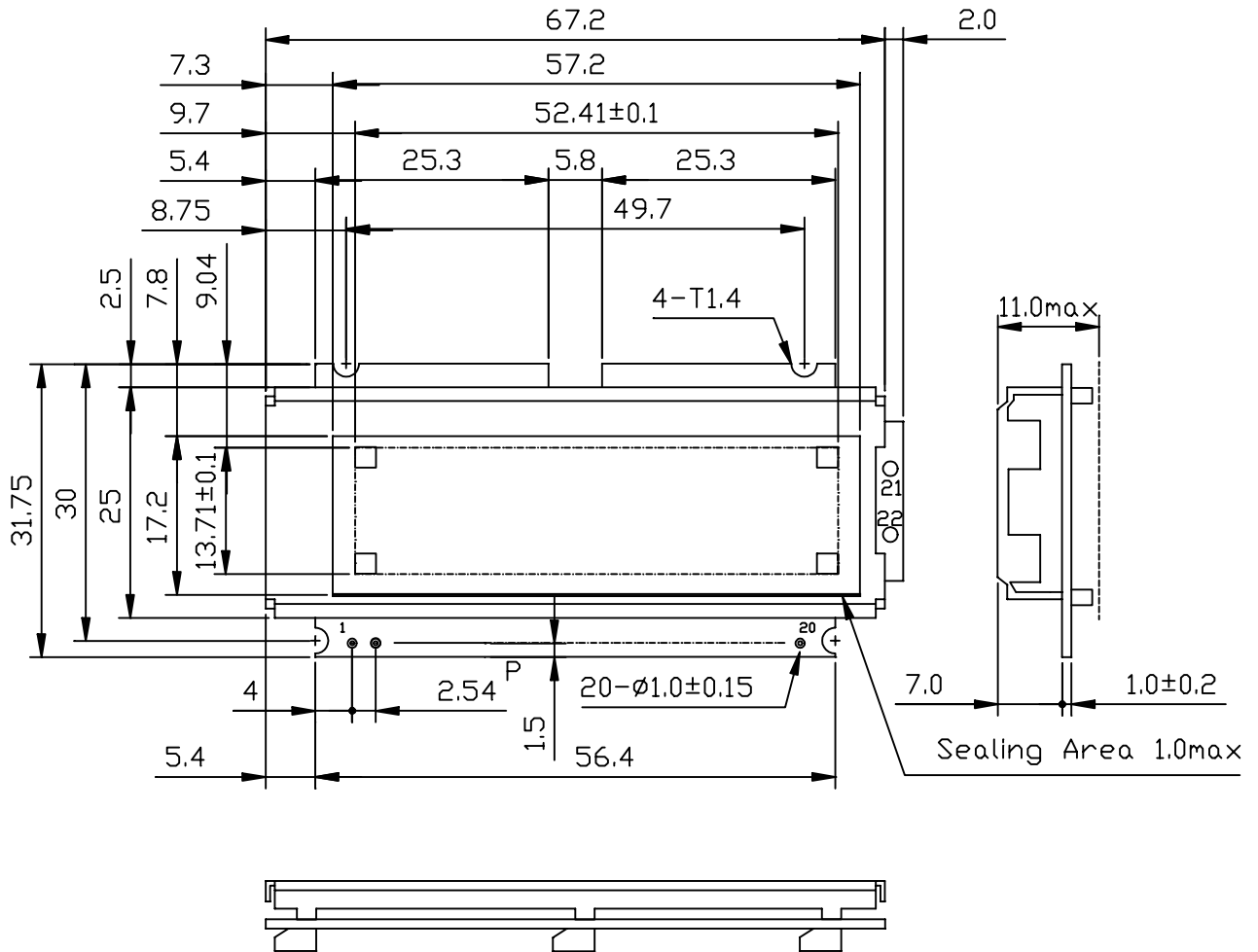

UNIT : mm
SCALE : NTS
NOT SPECIFIED TOLERANCE IS ± 0.3 mm

8. DETAIL DRAWING OF DOT MATRIX

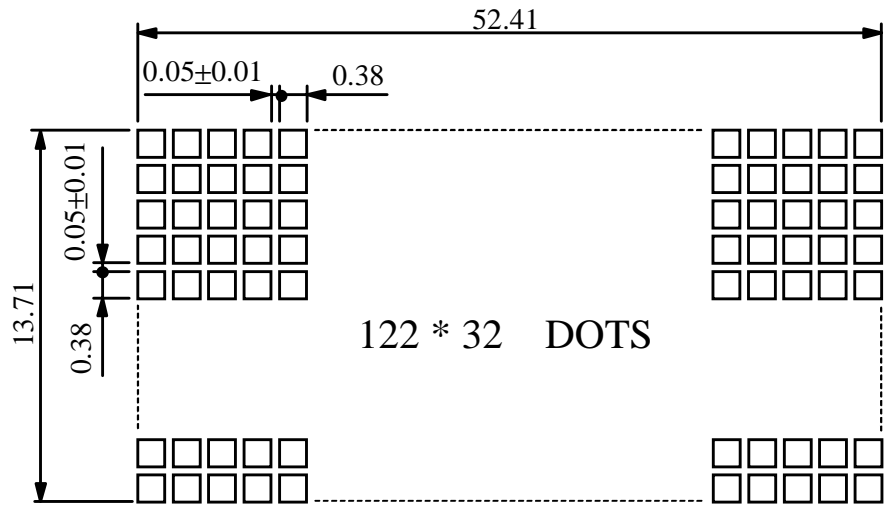

122 * 32 DOTS

UNIT : mm
SCALE : NTS
NOT SPECIFIED TOLERANCE IS ±0.1

9. POWER SUPPLY

9.1 POWER SUPPLY FOR LCM

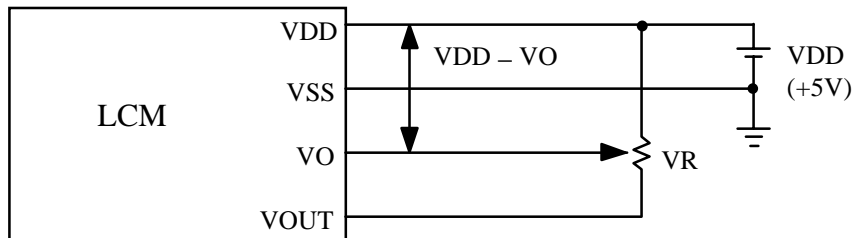

VDD - VO : LCD DRIVING VOLTAGE
VR : 10KΩ ~ 20KΩ

9.2 POWER SUPPLY FOR LED BACK LIGHT

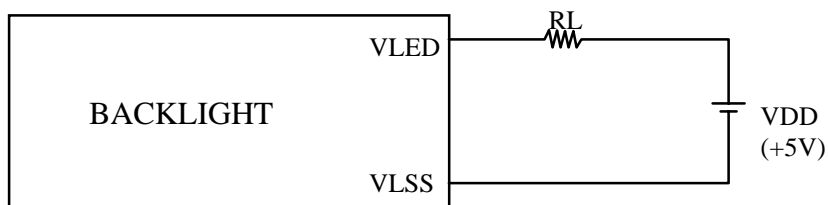

RECOMMENDED RESISTOR RL : 4.4~11.1Ω, 1/4WATT (CONTROLLED BY USER)
* THE BRIGHNESS WOULD BE ALTERED SUBJECT TO DIFFERENT VALVES OF RL

10. BLOCK DIAGRAM

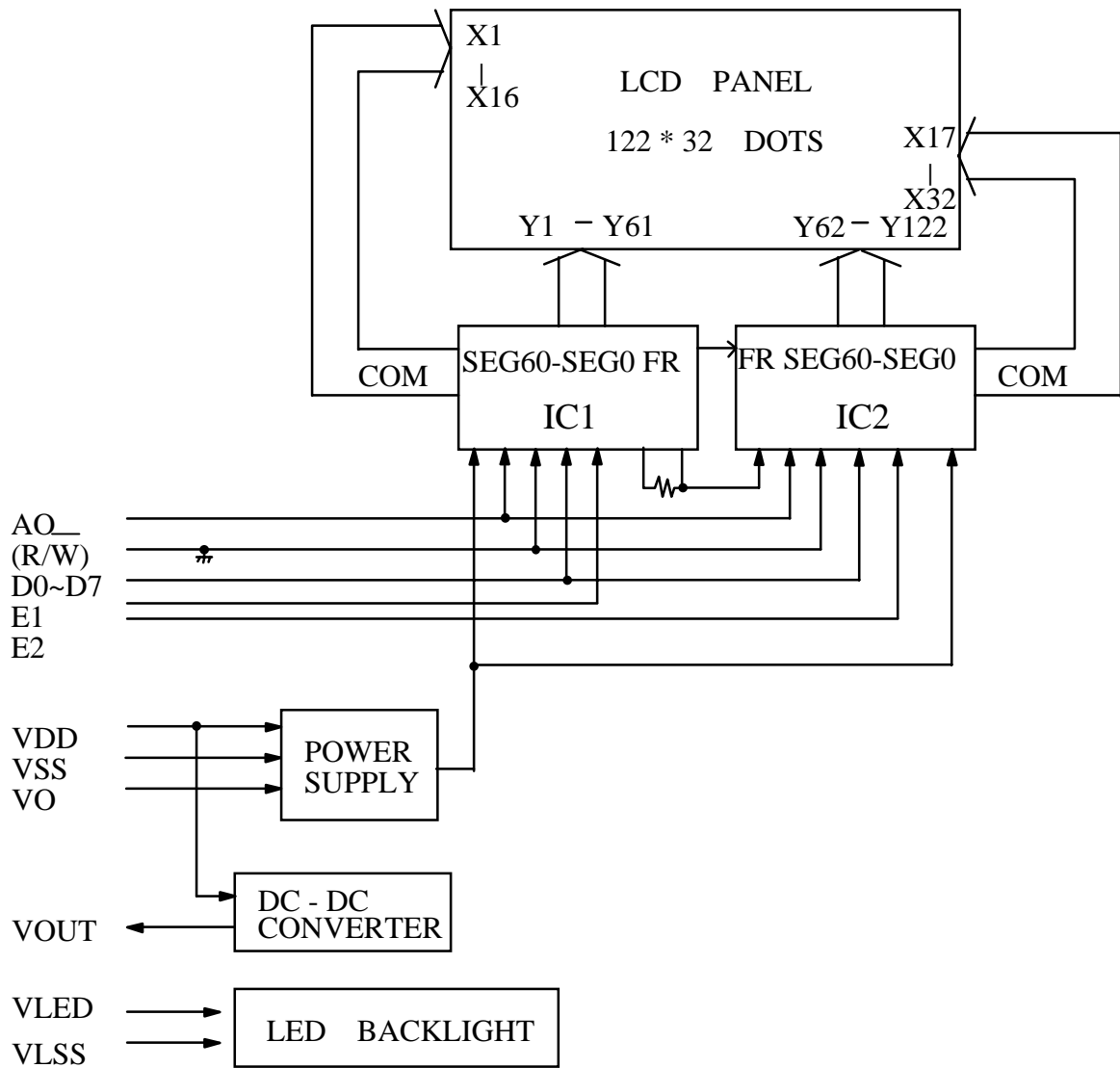

11. INTERFACE SIGNALS .

PIN NO .	SYMBOL	DESCRIPTION
1	VSS	GROUND (0V)
2	VDD	POWER SUPPLY FOR LOGIC CIRCUIT
3	V0	OPERATING VOLTAGE FOR LCD DRIVING
4	VOUT	POWER SUPPLY FOR LCD DRIVING (GENERATED BY DC - DC , -5V)
5	A0	DATA/COMMAND SELECT INPUT A0 = 0 : COMMAND A0 = 1 : DATA
6	E1	ENABLE CLOCK INPUT FOR IC1
7	E2	ENABLE CLOCK INPUT FOR IC2
8	DB0	TRI - STATE , BI - DIRECTIONAL I/O BUS
9	DB1	TRI - STATE , BI - DIRECTIONAL I/O BUS
10	NC	NO CONNECTION
11	NC	NO CONNECTION
12	DB2	TRI - STATE , BI - DIRECTIONAL I/O BUS
13	DB3	TRI - STATE , BI - DIRECTIONAL I/O BUS
14	DB4	TRI - STATE , BI - DIRECTIONAL I/O BUS
15	DB5	TRI - STATE , BI - DIRECTIONAL I/O BUS
16	DB6	TRI - STATE , BI - DIRECTIONAL I/O BUS
17	DB7	TRI - STATE , BI - DIRECTIONAL I/O BUS
18	NC	NO CONNECTION
19	VLED	POWER SUPPLY FOR LED BACKLIGHT
20	VLSS	POWER SUPPLY FOR LED BACKLIGHT
21	VLED	POWER SUPPLY FOR LED BACKLIGHT
22	VLSS	POWER SUPPLY FOR LED BACKLIGHT