

AS1602 — Dual Channel Active EMI & ESD Suppressor for Ethernet Applications

GENERAL DESCRIPTION

The AS1602 is a single-chip, highly integrated CMOS solution for Common Mode (CM) noise suppression & transient voltage protection in Ethernet applications. Typical applications are 10/100/1000 Ethernet systems where compliance to tougher EMC standards is required.

Applications include compliance to EMI Emissions (Class B), and/or EMI Immunity standards (Level 3 or higher), IEC61000-4-2 Air/Contact Discharge protection (up to $\pm 25\text{kV}$ Air Discharge), as well as Cable Discharge Events protection (up to $\pm 12\text{kV}$).

The AS1602 EMI/ESD Suppressor has been architected and designed to provide system level ESD protection and EMI suppression in Ethernet products, enabling an easier path to system EMC compliance.

The AS1602 utilizes Akros Silicon's patented Active Choke technology which offers superior Common Mode reduction and immunity compared to passive filtering techniques in Ethernet applications. The adaptive and continuous suppression operates over the entire Ethernet signal bandwidth, and it compensates for many variables that are the source of common mode noise in Ethernet systems. It also improves the differential-to-common mode balance of the system. This enables system designers to meet EMI emissions and EMI immunity requirements from the start of the design.

In addition, the AS1602 includes highly robust ESD/Surge protection diodes to protect the Ethernet PHY from various transient overvoltage events. These are built using Akros' proprietary design and layout techniques to safely deal with very high current densities in a CMOS process without creating voltage and/or thermal overstress that causes damage to the device.

Each AS1602 supports two twisted pair interfaces. 10/100 applications require one AS1602 device while 10/100/1000 applications require two AS1602 devices. The AS1602 is available in a small footprint 16-pin QSOP Reduction of Hazardous Substance (RoHS) compliant package.

Applications

- Ethernet systems requiring additional CM suppression to meet EMC Class B emissions or higher EMI immunity requirements and ESD protection.
- POE and Non-PoE Ethernet systems
- VoIP Phones, IP Cameras, WAPs, Routers, Switches
- Set Top Boxes, Networked Printers and Appliances, Desktop and Laptop Computers

Application Examples

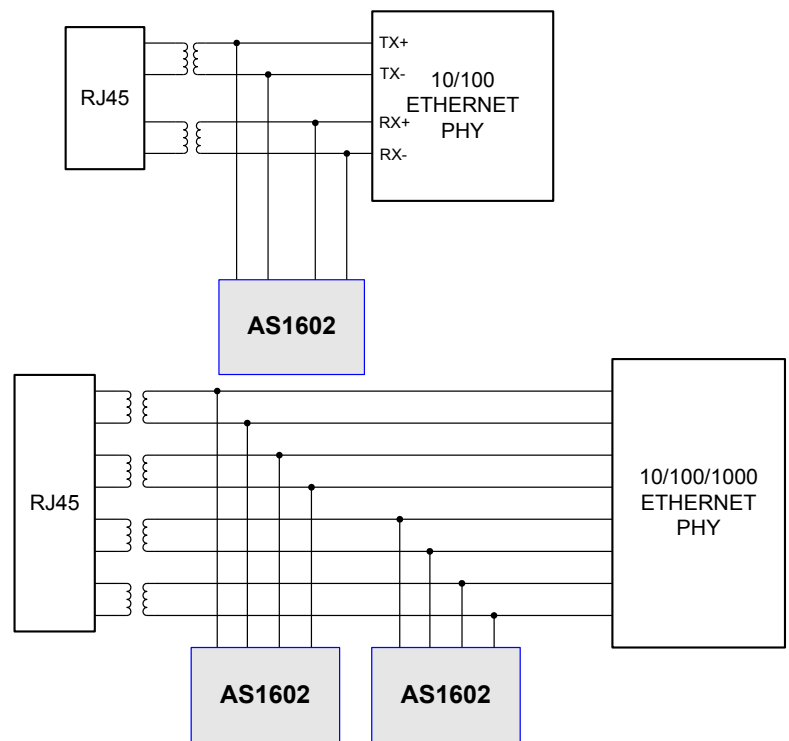

Akros Silicon, Inc.

262 Santa Ana Court, Sunnyvale, CA 94085 USA
408.746.9000 • www.AkrosSilicon.com

AS1602 — Duel Channel Active EMI & ESD Suppressor for Ethernet Applications

FEATURES

The AS1602 is fully integrated and architected at a system level to provide the following features:

- Enables system designers to comply with:
 - CISPR22 and FCC Part 15, Class B requirements for Radiated and Conducted Emissions.
 - IEC 61000-4-3/6 requirements for Radiated and Conducted Immunity, Level 3 or higher.
 - IEC 61000-4-2 ESD (Air Discharge) of $\pm 25\text{kV}$.
 - IEC 61000-4-2 ESD (Contact Discharge) of $\pm 12\text{kV}$.
 - Cable Discharge Event (CDE) of $\pm 12\text{kV}$.
- Provides up to 10dB of additional common mode noise suppression over the frequency of 1MHz to 125MHz when used with Ethernet magnetics.
- Robust built-in ESD suppressors protect the Ethernet PHY and improve system ESD performance.
- JESD22-A114, ESD, HBM of $\pm 8\text{kV}$.
- Interfaces to standard Ethernet transformers and 10/100/1000 Ethernet PHYs.
- Uses a single standard power rail (3.3V or 2.5V).
- Open drain output stage that can be biased from 1.8V to 3.3V using transformer center-tap supply as needed based on choice of Ethernet PHY.
- Flow-through routing for ease of board layout.
- Typical power consumption of 90mW.
- Low power mode available for tight power budgets.
- Industrial temperature range (-40°C to 85°C).

Akros Silicon, Inc.

262 Santa Ana Court, Sunnyvale, CA 94085 USA
408.746.9000 ▪ www.AkrosSilicon.com

TABLE OF CONTENTS

GENERAL DESCRIPTION..... 1
 Applications..... 1
 Application Examples..... 1
 FEATURES..... 2
 TABLE OF CONTENTS..... 3
 FIGURES..... 3
 TABLES..... 4
 PIN ASSIGNMENTS AND DESCRIPTIONS..... 5
 TYPICAL CHARACTERISTICS..... 8
 FUNCTIONAL DESCRIPTION..... 10
 Common Mode Noise..... 10
 Active Choke Technology..... 11
 Transient Threats..... 11
 Akros ESD Protection Design..... 12
 Performance/Power Control Pins..... 13
 HGM Pin..... 13
 HBW Pin..... 13
 SYSTEM DESIGN & LAYOUT CONSIDERATIONS..... 13
 AS1602 Placement..... 13
 Ethernet Signal Polarity Interchangeability..... 13
 Ethernet Signal Flow-Through Routing..... 13
 APPLICATION INFORMATION..... 14
 PACKAGE SPECIFICATIONS..... 16
 Contact Information..... 17
 Important Notices..... 17
 Legal Notice..... 17
 Reference Design Policy..... 17
 Life Support Policy..... 18
 Substance Compliance..... 18

FIGURES

Figure 1 – AS1602 Pin Assignments..... 5
 Figure 2 – Common Mode Rejection with Typical 2-Core PoE Compatible Transformer using 3-Wire PHY-Side Choke..... 8
 Figure 3 – Common Mode Rejection with Typical 3-Core PoE Compatible Transformer with Media Side Chokes..... 8
 Figure 4 – DM-CM Conversion in Receiving Data from UTP with Typical 2-Core PoE Compatible Transformers using 3-Wire PHY-Side Choke..... 9
 Figure 5 – AS1602 Return Loss with Typical 3-Core PoE Compatible Transformer with Media Side Chokes..... 9
 Figure 6 – AS1602 Insertion Loss..... 10
 Figure 7 – AS1602 Block Diagram..... 12
 Figure 8 – Typical FE Application Circuit..... 14
 Figure 9 – Typical GE Application Circuit..... 15
 Figure 10 – 16-Pin QSOP (150 Mil) Dimensions..... 16

AS1602 — Duel Channel Active EMI & ESD Suppressor for Ethernet Applications

TABLES

Table 1 – AS1602 Signal Descriptions.....	5
Table 2 – Absolute Maximum Ratings	6
Table 3 – Recommended Operating Conditions	6
Table 4 – Electrical Characteristics	6
Table 5 – Digital input Characteristics.....	7

Akros Silicon, Inc.

262 Santa Ana Court, Sunnyvale, CA 94085 USA
408.746.9000 ■ www.AkrosSilicon.com

AS1602 — Duel Channel Active EMI & ESD Suppressor for Ethernet Applications

PIN ASSIGNMENTS AND DESCRIPTIONS

Figure 1 – AS1602 Pin Assignments

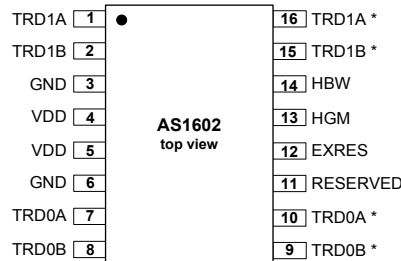

* Not connected internally – pin named to enable PCB flow-through routing.

Table 1 – AS1602 Signal Descriptions

PIN	NAME	I/O ¹	DESCRIPTION
1, 16	TRD1A	A, OD	PHY media differential pair 1 positive or negative signal. Note that circuit electrical connection is to pin 1 only. Pin 16 is named the same to enable through-routing on the PCB, however it is <i>not</i> connected internally.
2, 15	TRD1B	A, OD	PHY media differential pair 1 positive or negative signal. Note that circuit electrical connection is to pin 2 only. Pin 15 is named the same to enable through-routing on the PCB, however it is <i>not</i> connected internally.
3, 6	GND	P	Board ground - same as Ethernet PHY ground
4, 5	VDD	P	Analog VDD. 3.3V ± 5% or 2.5V ± 5% supply can be used. VDD can be shared with transformer center-tap supply, but is not required. Note that the transformer center-tap supply voltage (VCT) must always be <i>equal to</i> or less than VDD.
7, 10	TRD0A	A, OD	PHY media differential pair 0 positive or negative signal. Note that circuit electrical connection is to pin 7 only. Pin 10 is named the same to enable through-routing on the PCB, however it is <i>not</i> connected internally.
8, 9	TRD0B	A, OD	PHY media differential pair 0 positive or negative signal. Note that circuit electrical connection is to pin 8 only. Pin 9 is named the same to enable through-routing on the PCB, however it is <i>not</i> connected internally.
11	RESERVED	-	Reserved - leave open
12	EXRES	A	External bias resistor. For VDD = 2.5V use 8.06kΩ ±1%. For VDD = 3.3V use 10.7kΩ ±1%. Connect resistor between EXRES pin and GND
13	HGM	DI	Allows trade-off between desired CM rejection performance and device power consumption: FLOATING: Default setting - recommended normal operating condition LOW: Lower power mode setting - reduces CM rejection performance to reduce power consumption. See “Performance/Power Control Pins” on page 12 for additional details. HIGH: Reserved - should not be used
14	HBW	DI	Allows control of CM rejection performance by changing internal loop bandwidth. May be used in some systems to optimize EMI performance. FLOATING: Default setting - recommended normal operating condition LOW: Reserved - should not be used HIGH: Increases loop bandwidth to increase CM rejection performance. May be used in some systems to optimize EMI performance. See “Performance/Power Control Pins” on page 12 for additional details.

1. OD = Open Drain, A = Analog signal, DI = 3-state Digital Input signal, P = Power

AS1602 — Duel Channel Active EMI & ESD Suppressor for Ethernet Applications

Table 2 – Absolute Maximum Ratings

PARAMETER	MAX	UNIT
PHY media TRDn pins	5.0	Volt
All other pins	3.6	Volt
Supply voltage (VDD)	3.6	Volt
ESD Human Body Model (JESD22-A114) ¹	8	kV
ESD Charged Device Model (JESD22-C101) ¹	500	Volt
System ESD (IEC 61000-4-2: Air Discharge) ²	25	kV
System ESD (IEC 61000-4-2: Contact Discharge) ²	12	kV
Cable Discharge Event (CDE) ²	12	kV
Storage temperature	165	°C
Junction temperature	125	°C

- Human Body Model and Charged Device Model ESD limits are specified at the chip level.
- Air Discharge, Contact Discharge, and Cable Discharge Event maximum limits are specified at the system level.

Table 3 – Recommended Operating Conditions

SYMBOL	PARAMETER	MIN	TYP	MAX	UNIT
V _{DD}	3.3 V Power supply (VDD)	3.13	3.3	3.47	Volt
	2.5V Power supply (VDD)	2.37	2.5	2.63	Volt
V _{CT}	DC common mode of Ethernet signals (transformer center-tap supply - see note 1)	1.8 -5%		3.3 +5%	Volt
T _A	Operating temperature range	-40	–	85	°C

- The transformer center-tap supply voltage (V_{CT}) must always be *equal to or less than* V_{DD}.

Table 4 – Electrical Characteristics

PARAMETER	TEST CONDITIONS	MIN	TYP	MAX	UNIT
Differential signal insertion loss	0.1 MHz - 100 MHz	–	0	0.2	dB
Differential output capacitance (between TRDnA and TRDnB pins)	–	–	4.5	–	pF
Common mode PHY noise rejection (25Ω CM impedance)	at 1 MHz	30	–	–	dB
	at 100 MHz	10	–	–	dB
Common mode PHY noise rejection additive to transformer ³	At 100 MHz	10	–	–	dB
Differential IM3	60 MHz full scale with 100Ω differential resistor across terminals	–	-40	–	dB
Common mode-to-differential mode imbalance	1 MHz - 100 MHz	–	-34+19.2log(f/50 MHz)	–	dB
Power dissipation	Default mode: HGM = floating V _{DD} = 2.5V, V _{CT} = 1.8V	–	90	130 ²	mW
	Low Power Mode: HGM = Low V _{DD} = 2.5V, V _{CT} = 1.8V	–	55	80 ²	

AS1602 — Duel Channel Active EMI & ESD Suppressor for Ethernet Applications

1. Typical specifications are for $T_a = +25^{\circ}\text{C}$ and $V_{DD} = 2.5\text{V}$. Typical specifications not 100% tested. Performance guaranteed by design and/or other correlation methods.
2. Maximum power consumption is with +5% supplies and over all process/temperature range.
3. This measurement is done with typical Ethernet transformer. Unless otherwise specified, all other performance measurements are for standalone AS1602 without Ethernet transformer.

Table 5 – Digital input Characteristics

SYMBOL	PARAMETER	TEST CONDITIONS	MIN	MAX	UNIT
V_{IH}	Input HIGH level	$V_{CC} = 2.5\text{V}$	1.78	3.47 (3.3V + 5%)	V
		$V_{CC} = 3.3\text{V}$	2.0	3.47 (3.3V + 5%)	
V_{IL}	Input LOW level	$V_{CC} = 2.5\text{V}$	-0.30	0.5	V
		$V_{CC} = 3.3\text{V}$	-0.30	0.5	
I_{IL}, I_{IH}	Input leakage, LOW and HIGH levels	$V_{CC} = 2.5\text{V}$	± 25	± 40	μA
		$V_{CC} = 3.3\text{V}$	± 33	± 53	

Akros Silicon, Inc.

262 Santa Ana Court, Sunnyvale, CA 94085 USA
408.746.9000 • www.AkrosSilicon.com

AS1602 — Duel Channel Active EMI & ESD Suppressor for Ethernet Applications

TYPICAL CHARACTERISTICS

Figure 2 – Common Mode Rejection with Typical 2-Core PoE Compatible Transformer using 3-Wire PHY-Side Choke

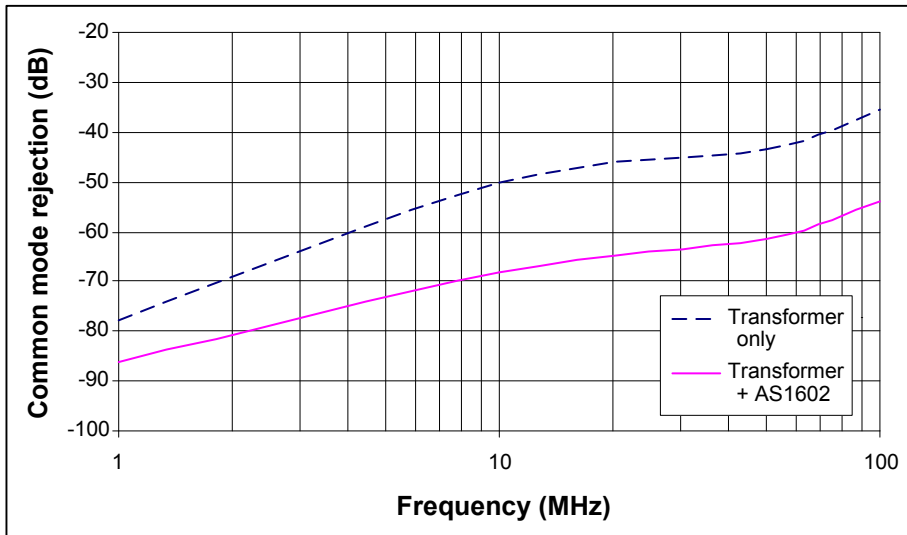
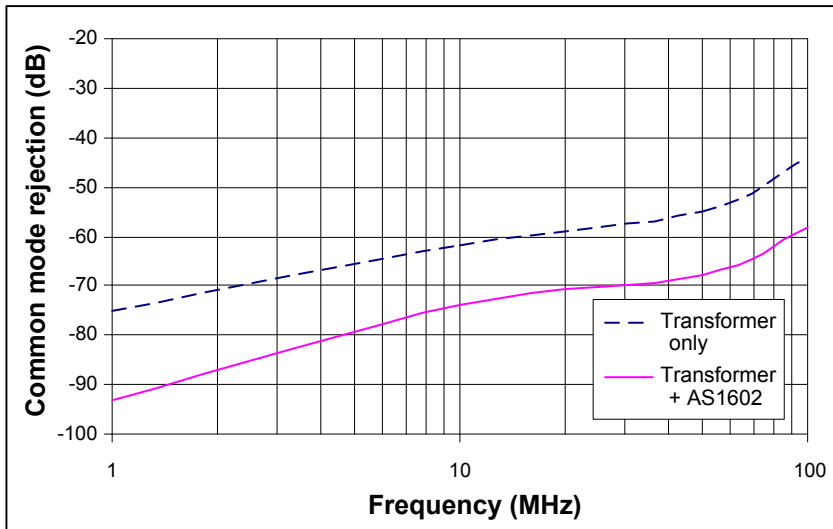

Figure 3 – Common Mode Rejection with Typical 3-Core PoE Compatible Transformer with Media Side Chokes



AS1602 — Duel Channel Active EMI & ESD Suppressor for Ethernet Applications

Figure 4 – DM-CM Conversion in Receiving Data from UTP with Typical 2-Core PoE Compatible Transformers using 3-Wire PHY-Side Choke

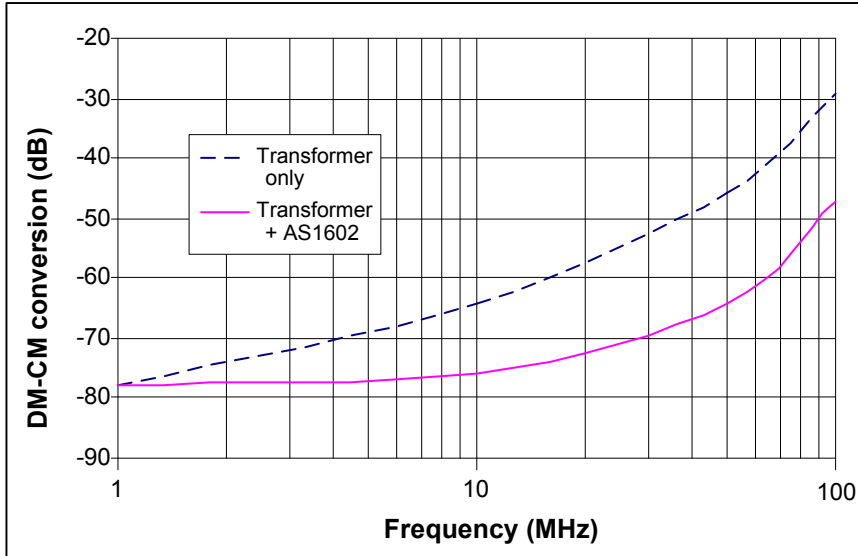
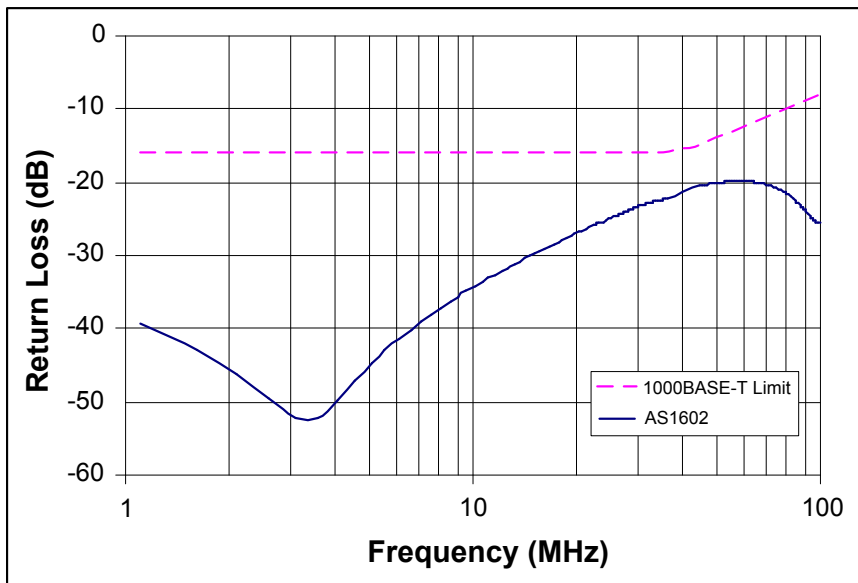
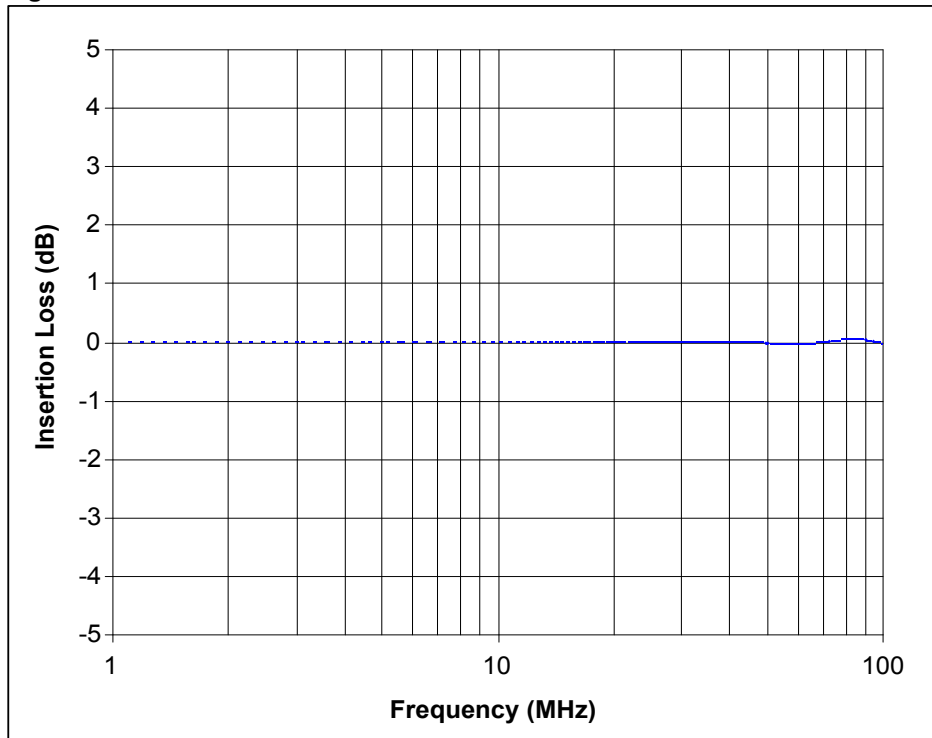

Figure 5 – AS1602 Return Loss with Typical 3-Core PoE Compatible Transformer with Media Side Chokes



AS1602 — Duel Channel Active EMI & ESD Suppressor for Ethernet Applications

Figure 6 – AS1602 Insertion Loss



FUNCTIONAL DESCRIPTION

Common Mode Noise

The AS1602 compensates for many variables that are the source of common mode noise in Ethernet systems. These include: common mode noise from Ethernet PHY DACs and drivers, variations in Ethernet line signals caused by transformer and passive component mismatches, variations in PC board designs, and different vendor PHY designs.

Most Ethernet PHYs use switched mode D/A converters and drivers to transmit complex modulated signals on the twisted pair. There are inherent common mode switching transients that occur in output driver designs. Switched mode drivers coupled with leakage inductance of the line transformer creates a common mode kick. This common mode noise is coupled through to the twisted pair line via transformer interwinding capacitance. This can result in a significant EMI emissions issue for Ethernet systems that desire

good margin from CISPR22 and FCC part 15 Class B specifications.

Ethernet transformers provide common mode rejection through PHY-side autoformer and in-line chokes. Mismatches in the autoformer inductance can lead to differential-to-common mode conversion. Parasitics of the autoformer also limit common mode rejection capability. This residual common mode noise is coupled to the line side through interwinding capacitance.

Additional differential to common mode conversion issues come from board layout mismatches and other passive component mismatches on the PCB. Common mode imbalance at the input of the system can create common mode to differential conversion and significantly impact EMI immunity performance.

As a result, meeting system level EMI requirements is very challenging.

Akros Silicon, Inc.

262 Santa Ana Court, Sunnyvale, CA 94085 USA
408.746.9000 • www.AkrosSilicon.com

AS1602 — Duel Channel Active EMI & ESD Suppressor for Ethernet Applications

Active Choke Technology

The AS1602 incorporates Akros Silicon's patented Active Choke technology. The AS1602 is placed between the Ethernet PHY and the line transformer. Its adaptive circuitry monitors both the positive and negative signals of each differential pair and shunts any common mode noise to ground. As a result, noise is prevented from getting through the transformer to the unshielded twisted-pair (UTP).

The AS1602 preserves the integrity of the Ethernet signal by providing very low common mode impedance while maintaining high differential impedance and low differential capacitive loading.

The AS1602 is designed to suppress any common mode noise present in the Ethernet signal pair, irrespective of whether it originates from the PHY side or the UTP side. It provides immunity against large signal common mode events by shunting the common mode signal currents back to ground. Therefore, the Ethernet PHY receiver does not see any common mode movement, enabling it to maintain good link performance.

As shown in Figure 7, the output stage of the AS1602 uses open-drain drivers similar to the most common Ethernet PHYs. The AS1602 can tolerate output DC common mode on its TRD pins within a range of 1.8V to 3.3V. This allows the AS1602 to work seamlessly with any Ethernet PHY and transformer that uses the center-tap to DC-bias the PHY.

The AS1602 architecture uses high precision active analog circuitry which suppresses only the common mode components of the disturbances without impacting the differential signal. This technology provides superior differential-to-common mode impedance balance over traditional transformer solutions.

The AS1602 provides low differential capacitive loading to the Ethernet signals and meets all the common mode-to-differential balance and distortion requirements per the 10/100/1000 Base-T section of the IEEE® 802.3 Ethernet specification.

Transient Threats

Silicon-based electronic devices need protection from spurious events that exert voltage/current stresses exceeding the normal operating limits of the devices. Such events are generally classified as ESD (Electro-Static Discharge) events.

ESD strikes have two modes: differential mode strikes and common mode strikes. Differential mode strikes are strikes which are applied to one pin at a time. These strikes go through the transformer and are the hardest to protect against. Contact/Air Discharge and Cable Discharge event (CDE) can be differential strikes. CDE has become more important in recent years due to advent of cat-5 and better cables. Ethernet cables are frequently dragged across plastic/carpet flooring or through ducts. Charge can accumulate on the cable through triboelectric effect or induction. The newer cat-5 (or better) cables can hold the charge for a longer period of time relative to older cat1-4 cables. As PHY transceivers have been scaling to finer geometry with lower breakdown voltages, their ability to tolerate large cable discharge events is also limited. Plugging a charged cable into RJ45 jack can lead to an over-voltage stress that can damage sensitive PHY devices.

Common mode strikes normally include EFTB (Electrical Fast Transient/Burst) and surge. The first level of protection of common mode strikes is provided by the isolation of the Ethernet transformer.

Both differential mode and common mode strikes have been the major issues for Ethernet equipment. These transient threats can very easily damage the Ethernet PHYs and can also damage the Ethernet transformer if appropriate design precautions are not taken.

Akros Silicon, Inc.

262 Santa Ana Court, Sunnyvale, CA 94085 USA
408.746.9000 • www.AkrosSilicon.com

AS1602 — Duel Channel Active EMI & ESD Suppressor for Ethernet Applications

Akros ESD Protection Design

The AS1602 provides transient protection for both differential mode and common mode ESD events through proprietary CMOS design and layout techniques for low capacitive loading and low inductive effects in protection diodes.

Positive ESD strikes are handled through a stack of diodes that are biased to ensure operation with wide range of V_{DD} and V_{CT} supply voltages and prevent clipping/degradation of Ethernet signals.

Negative ESD strikes are handled through output NMOS bulk diodes, which are also hardened to handle large surge energy. Design prevents snapback of the PHY output NMOS devices by fast turn-on and efficient energy dissipation through ESD structures.

Proprietary design techniques allow the design to handle both moderate energy/fast transients that create high thermal stress as well as high energy/slow transient events that create tremendous voltage overstress.

At the system level, the AS1602 can tolerate over $\pm 25\text{kV}$ of IEC61000-4-2 air discharge strikes and $\pm 12\text{kV}$ of Cable Discharge Events, and provides protection for Ethernet PHY.

Figure 7 – AS1602 Block Diagram

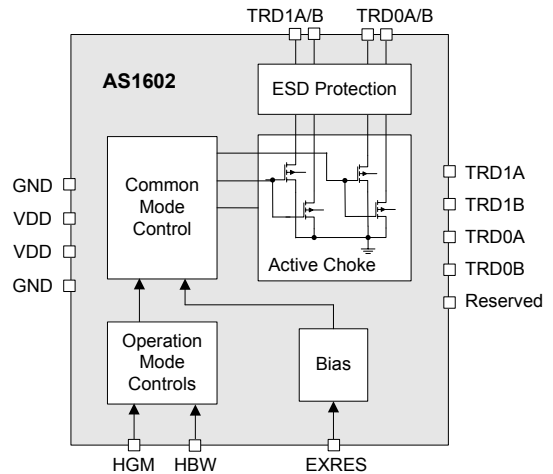

Akros Silicon, Inc.

262 Santa Ana Court, Sunnyvale, CA 94085 USA
408.746.9000 • www.AkrosSilicon.com

AS1602 — Duel Channel Active EMI & ESD Suppressor for Ethernet Applications

Performance/Power Control Pins

EMI performance varies significantly from system to system. The AS1602 provides two digital pins (HGM and HBW) that allow various levels of hardware control and performance optimization of the device. The HGM and HBW are 3-input state pins (Low, High and Floating). The Floating state is detected internally by the device as a valid state. For default operation, both pins should be left floating. These pins can be driven by another digital IC with tri-stateable outputs or tied in hardware to configure the desired operating mode.

HGM Pin

The default configuration is to leave the HGM pin floating which provides a trade-off between CM rejection performance and device power consumption.

If less rejection is needed in the Ethernet path, the HGM pin should be pulled LOW to select the Low Power Mode. In Low Power Mode, device power consumption is reduced by about 40% and CMRR performance is reduced by approximately 1dB at 100MHz.

HBW Pin

Setting the HBW pin HIGH selects HBW mode which allows system designers another dimension to improve performance by increasing the bandwidth of the internal active circuits. In some systems, this can provide additional performance benefits.

There is a broad range of line transformers that can be used in Ethernet applications. Setting HBW mode may cause oscillations in some systems depending on transformer parasitics. Therefore, HBW mode should only be used if the performance improvement of the default setting (HBW pin = Floating) is not adequate. Ethernet electrical performance should be tested sufficiently to ensure that no oscillatory behavior is seen when using the HBW mode setting.

HBW mode will typically improve the CMRR performance by approximately 1dB at 100MHz.

Note that the HBW mode can be used in conjunction with the HGM pin's Low Power mode.

Additional performance/power modulation can be achieved by changing the external bias resistor value (EXRES). For detailed characterization across operating modes, please refer to the relevant application note document.

SYSTEM DESIGN & LAYOUT CONSIDERATIONS

AS1602 Placement

The AS1602 is designed to mate closely with Ethernet magnetics for ease of board design. The AS1602 should be placed physically near the Ethernet transformer or integrated magnetics jack. Placement on same side of the PC-board as the transformer and the PHY is recommended to avoid vias on the Ethernet traces. The AS1602 should be placed such that pin 1 is facing the transformer or integrated magnetics jack.

Ethernet Signal Polarity Interchangeability

The AS1602 extracts only the common mode component of the Ethernet signals for processing. As a result, the polarity of the Ethernet signals to the AS1602 does not matter. This allows system designers to connect either the positive or negative polarity Ethernet signals to either the TRDnA or TRDnB pins - whichever is convenient for board routing and avoids the necessity of swapping the signals and the use of via insertions.

Ethernet Signal Flow-Through Routing

AS1602 is packaged to allow flow-through routing of the Ethernet differential pairs. Only one side of the package's Ethernet pins (1, 2, 7 and 8) are internally electrically connected to the CM rejection circuitry. Mirrored pins (16, 15, 10 and 9 respectively) are given the same name to enable easy flow-through routing with PC-board design tools.

For a more detailed discussion on designing with the AS1602 and layout considerations, please reference available design guide and application notes.

Akros Silicon, Inc.

262 Santa Ana Court, Sunnyvale, CA 94085 USA
408.746.9000 • www.AkrosSilicon.com

APPLICATION INFORMATION

Figure 8 – Typical FE Application Circuit

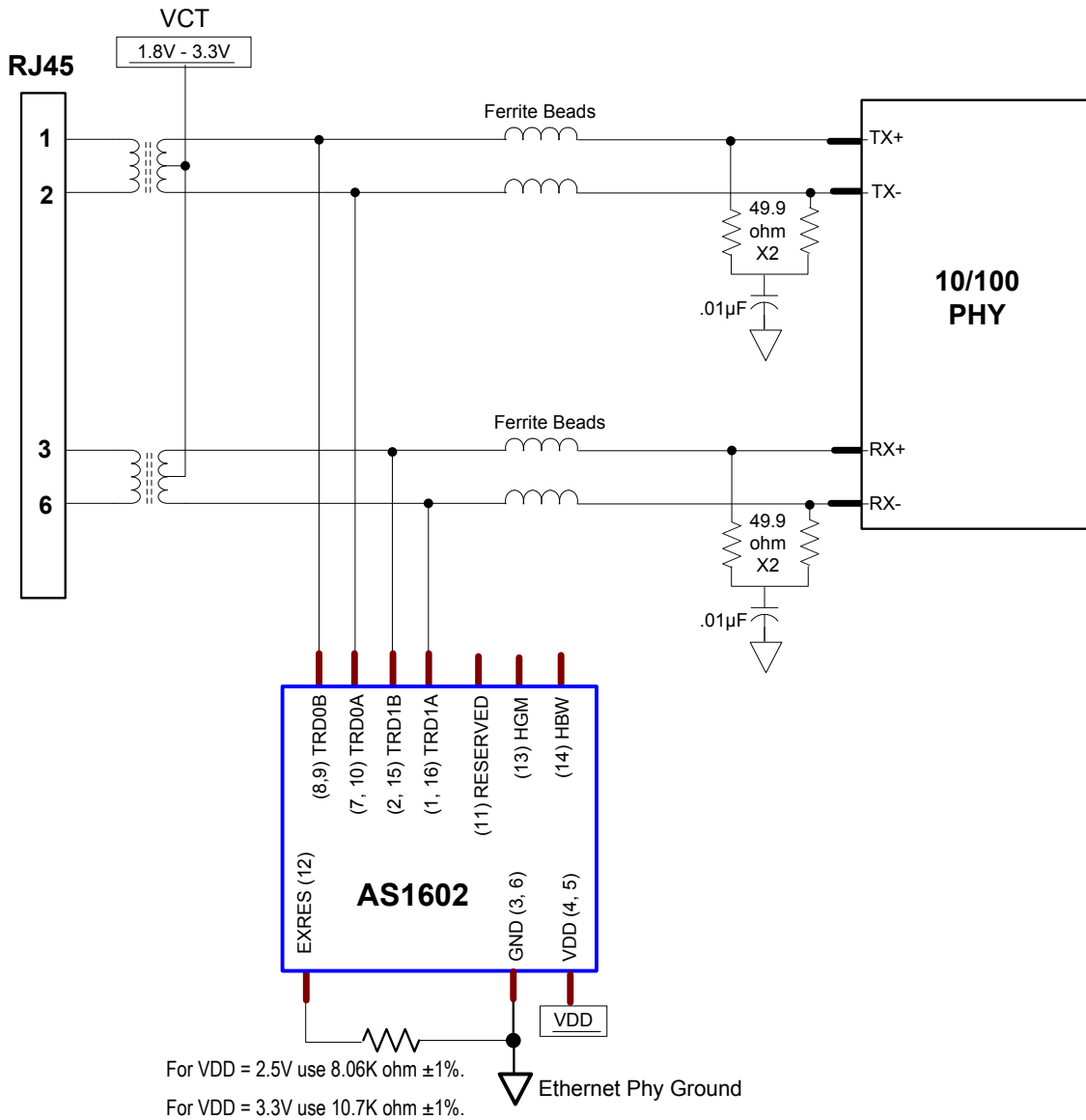

NOTE: This diagram is preliminary and subject to change at any time. It may not contain all information necessary to implement the application it represents. Please refer to application notes for details.

AS1602 — Duel Channel Active EMI & ESD Suppressor for Ethernet Applications

Figure 9 – Typical GE Application Circuit

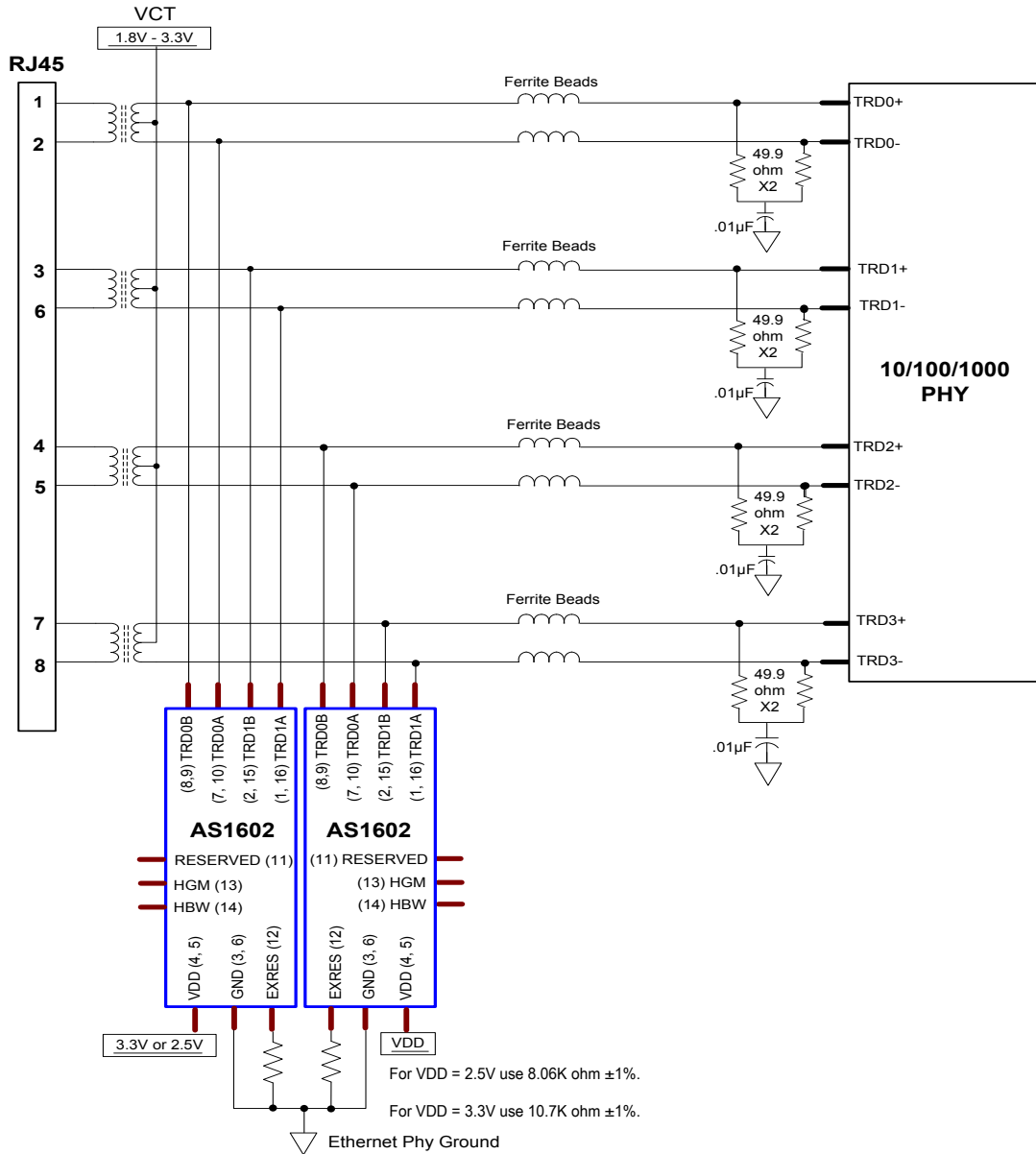

NOTE: This diagram is preliminary and subject to change at any time. It may not contain all information necessary to implement the application it represents. Please refer to application notes for details.

AS1602 — Dual Channel Active EMI & ESD Suppressor for Ethernet Applications

PACKAGE SPECIFICATIONS

Figure 10 – 16-Pin QSOP (150 Mil) Dimensions

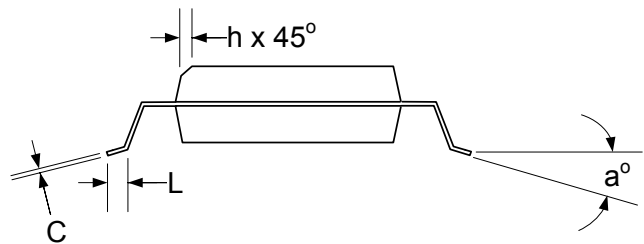
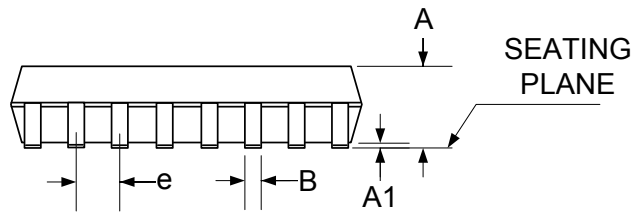
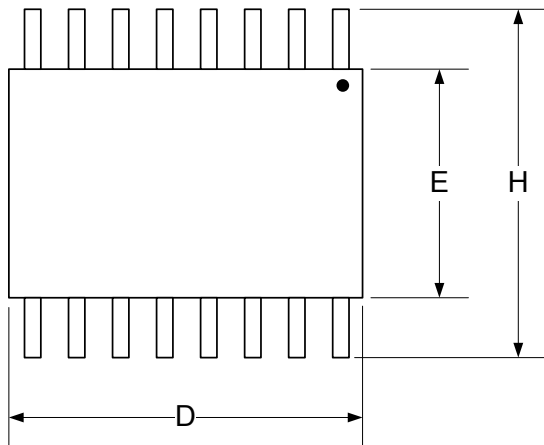

SYMBOL	INCHES		MILLIMETERS	
	MIN	MAX	MIN	MAX
A	0.060	0.068	1.35	1.75
A1	0.004	0.008	0.101	0.203
B	0.009	0.012	0.203	0.305
C	0.007	0.010	0.178	0.254
D	0.188	0.197	4.80	5.00
E	0.150	0.157	3.81	3.99
e	0.025 BSC		0.635 BSC	
H	0.230	0.244	5.84	6.20
h	0.010	0.016	0.254	0.38
L	0.023	0.029	0.58	0.74
a°	0°	8°	0°	8°

NOTES:

1. Lead width and lead thickness exclusive of solder plate.
2. Package outline exclusive of mold flashes and burr dimensions.
3. Allowable mold flash is 5 Mils per side.
4. Lead coplanarity is 0.003 inch maximum.

AS1602 — Duel Channel Active EMI & ESD Suppressor for Ethernet Applications

Contact Information

Akros Silicon, Inc.
262 Santa Ana Court
Sunnyvale, CA. 94085
USA

Tel: (408) 746 9000
Fax: (408) 746-9391
Email inquiries: marcom@akrossilicon.com
Website: <http://www.akrossilicon.com>

Important Notices

Legal Notice

Copyright © 2014 Akros Silicon™. All rights reserved. Other names, brands and trademarks are the property of others. Akros Silicon™ assumes no responsibility or liability for information contained in this document. Akros reserves the right to make corrections, modifications, enhancements, improvements, and other changes to its products and services at any time and to discontinue any product or services without notice. The information contained herein is believed to be accurate and reliable at the time of printing.

Reference Design Policy

This document is provided as a design reference and Akros Silicon assumes no responsibility or liability for the information contained in this document. Akros reserves the right to make corrections, modifications, enhancements, improvements and other changes to this reference design documentation without notice.

Reference designs are created using Akros Silicon's published specifications as well as the published specifications of other device manufacturers. This information may not be current at the time the reference design is built. Akros Silicon and/or its licensors do not warrant the accuracy or completeness of the specifications or any information contained therein.

Akros does not warrant that the designs are production worthy. Customer should completely validate and test the design implementation to confirm the system functionality for the end use application.

Akros Silicon provides its customers with limited product warranties, according to the standard Akros Silicon terms and conditions.

For the most current product information visit us at www.akrossilicon.com

AS1602 — Duel Channel Active EMI & ESD Suppressor for Ethernet Applications

Life Support Policy

LIFE SUPPORT: AKROS' PRODUCTS ARE NOT DESIGNED, INTENDED, OR AUTHORIZED FOR USE AS COMPONENTS IN LIFE SUPPORT DEVICES OR SYSTEMS. NO WARRANTY, EXPRESS OR IMPLIED, IS MADE FOR THIS USE. AUTHORIZATION FOR SUCH USE SHALL NOT BE GIVEN BY AKROS, AND THE PRODUCTS SHALL NOT BE USED IN SUCH DEVICES OR SYSTEMS, EXCEPT UPON THE WRITTEN APPROVAL OF THE PRESIDENT OF AKROS FOLLOWING A DETERMINATION BY AKROS THAT SUCH USE IS FEASIBLE. SUCH APPROVAL MAY BE WITHHELD FOR ANY OR NO REASON.

“Life support devices or systems” are devices or systems which (1) are intended for surgical implant into the human body, (2) support or sustain human life, or (3) monitor critical bodily functions including, but not limited to, cardiac, respirator, and neurological functions, and whose failure to perform can be reasonably expected to result in a significant bodily injury to the user. A “critical component” is any component of a life support device or system whose failure to perform can be reasonably expected to cause the failure of the life support device or system, or to affect its safety or effectiveness.

Substance Compliance

With respect to any representation by Akros Silicon that its products are compliant with RoHS, Akros Silicon complies with the Restriction of the use of Hazardous Substances Standard (“RoHS”), which is more formally known as Directive 2002/95/EC of the European Parliament and of the Council of 27 January 2003 on the restriction of the use of certain hazardous substances in electrical and electronic equipment. To the best of our knowledge the information is true and correct as of the date of the original publication of the information. Akros Silicon bears no responsibility to update such statements.

Akros Silicon, Inc.

262 Santa Ana Court, Sunnyvale, CA 94085 USA
408.746.9000 • www.AkrosSilicon.com