

# The MMA73x0L Analog Output Accelerometer Evaluation Boards

by: Kimberly Tuck and John Young  
Systems and Applications Engineers  
Tempe, AZ

## INTRODUCTION

This application note describes the MMA7360L (1.5g & 6g), MMA7340L (3g & 11g) and MMA7330L (4g & 12g) evaluation boards for Freescale's multi-axis (X, Y, Z) analog output LGA-14 packaged 3x5x1 mm<sup>3</sup> variable capacitance sensing accelerometers. This document provides the information about the evaluation board featuring the accelerometer

devices. The operation of the MMA73x0L accelerometers are explained including the circuit descriptions and diagrams, showing the pin-outs with the corresponding functionality of the features. This document also includes a quick start guide using the evaluation board.

Table 1. MMA73x0L Accelerometer Characteristics

| Part No. | Acceleration (g) | Sensitivity (mV/g) | Zero g Output (V) | V <sub>DD</sub> Supply Voltage (V) | I <sub>DD</sub> Current (μA) | Rolloff Frequency (Hz) | 0g-Detect | Package |
|----------|------------------|--------------------|-------------------|------------------------------------|------------------------------|------------------------|-----------|---------|
| MMA7360  | 1.5/6            | 800/206            | 1.65              | 3.3                                | 400                          | 400 X,Y<br>300 Z       | Yes       | LGA     |
| MMA7340  | 3/11             | 440/117.8          | 1.65              | 3.3                                | 400                          | 400 X,Y<br>300 Z       | Yes       | LGA     |
| MMA7330  | 4/12             | 308/83.6           | 1.4               | 2.8                                | 400                          | 400 X,Y<br>300 Z       | No        | LGA     |

The accelerometer evaluation boards are small circuit boards intended to be used for evaluating the accelerometers and developing prototypes quickly without requiring a PCB to be designed to accommodate for the small LGA package. It also provides a means for understanding the best mounting position and location of an accelerometer in the product with the provided board mounting points.

Some examples of the applications for these accelerometers are the following:

- 3D-Gaming:** Tilt and Motion Sensing, Event Recorder
- HDD MP3 Player:** Freefall Detection
- Laptop PC:** Freefall Detection, Anti-Theft
- Cell Phone:** Image Stability, Text Scroll, Motion Dialing, E-Compass
- Pedometer:** Motion Sensing
- PDA:** Text Scroll
- Navigation and Dead Reckoning:** E-Compass Tilt Compensation
- Robotics:** Motion Sensing

## DESCRIPTION

The MMA73x0L accelerometers are surface-micromachined integrated-circuit accelerometers. These devices consist of a capacitive sensing g-cell consisting of an X-Y and a Z cell all within a single package, which is sealed hermetically at the wafer level using a bulk micromachined cap wafer. The g-cell is the sensing element of the system which consists of polysilicon mechanical structures. Acceleration is detected when a displacement in X, Y, or Z is detected in the g-cells. The displacement creates a change in capacitance. The ASIC uses a switched capacitor technique to measure the g-cell capacitors and the acceleration data is extracted from a difference in the capacitance. The ASIC provides signal conditioning and filtering to convert the capacitance into a high level output voltage which is ratiometric and proportional to the acceleration. The g-cells are combined with the signal conditioning ASIC in a single integrated circuit package.

## RATIOMETRICITY

The MMA73x0L has a ratiometric output meaning that the output offset voltage and the sensitivity scale linearly with the applied supply voltage. That is, as supply voltage is increased, the sensitivity and offset increase linearly; as supply voltage decreases, offset and sensitivity decrease linearly. This is a key feature when interfacing to a microcontroller or an A/D converter because it provides system level cancellation of

supply induced errors in the analog to digital conversion process.

## CIRCUIT DESCRIPTION

Figure 1 and Figure 2 are circuit schematics of the accelerometer device describing the pin-outs. Figure 3 shows the output offset values of the device in all six orientations. This correlates with the polarity of the device shown in Figure 2.

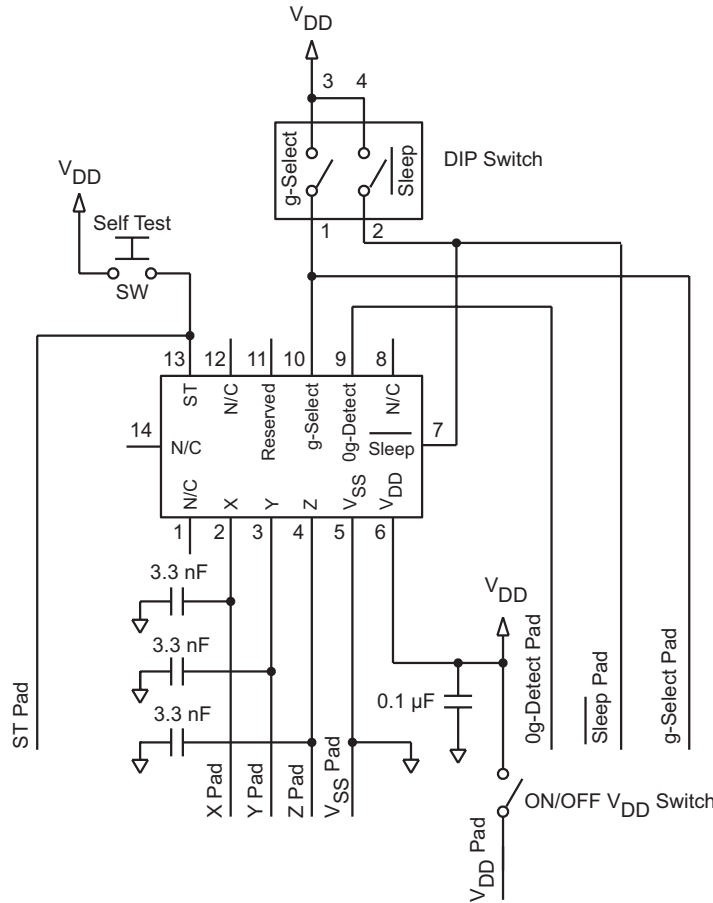

Figure 1. Schematic

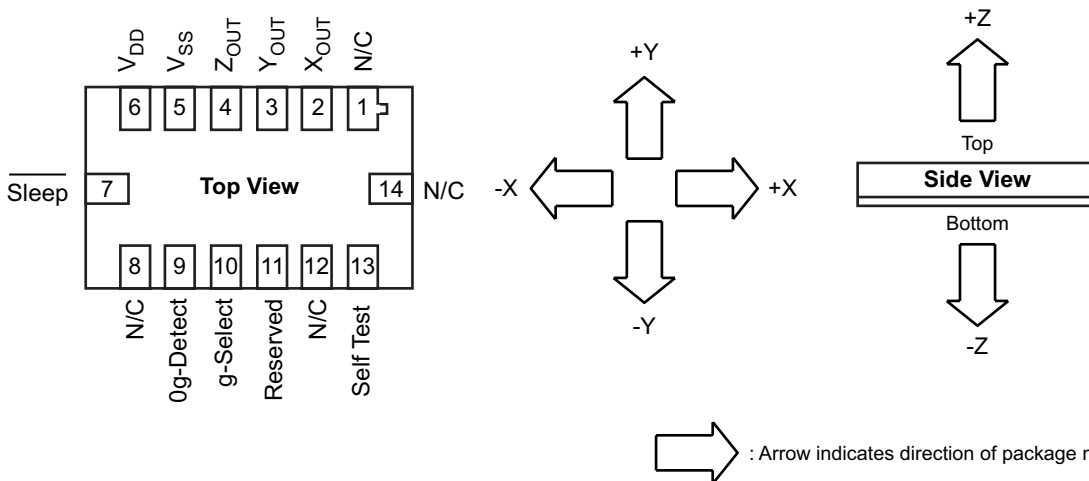
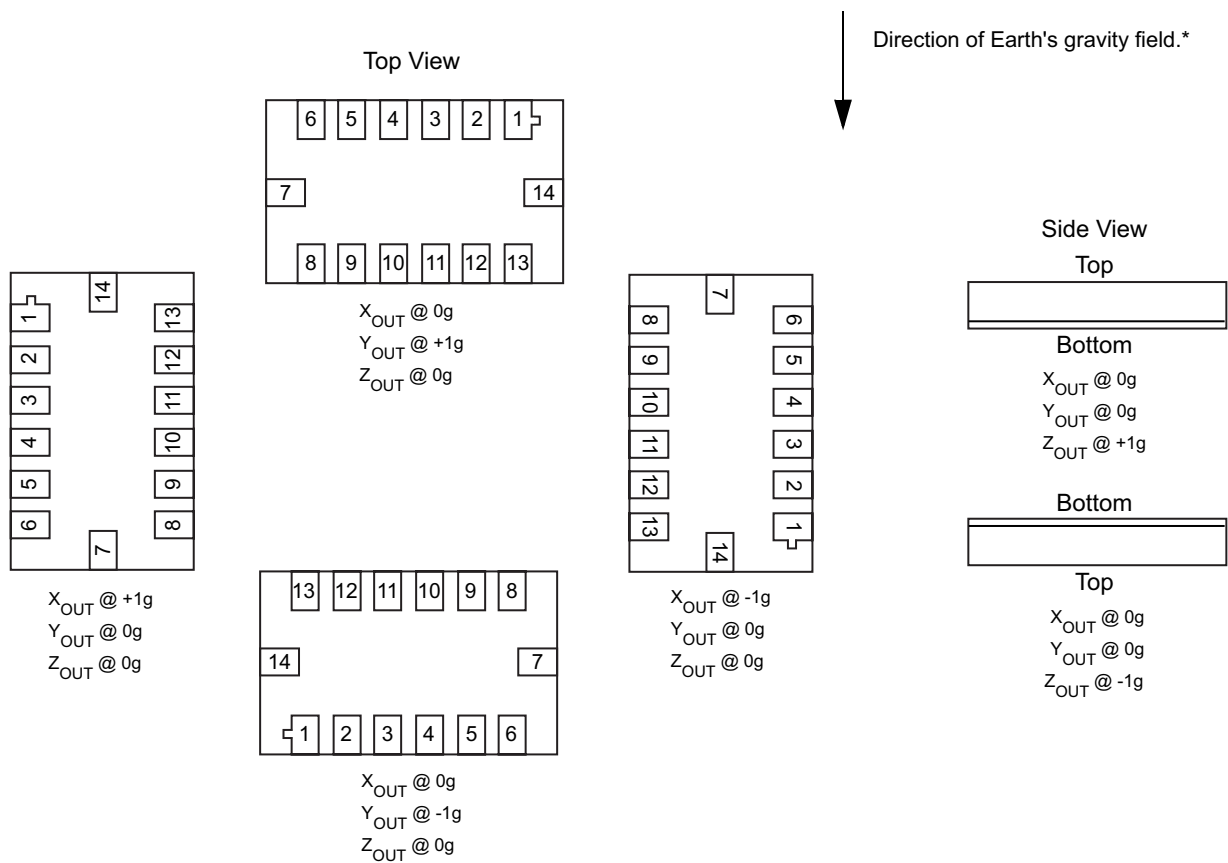

Figure 2. Pin-Out and Polarity for MMA73x0L



**Figure 3. Static Acceleration Showing Output Offset Values**

## PIN-OUT DESCRIPTIONS

### X, Y, Z Output (Pins 2, 3 and 4)

The X, Y and Z output pins provide the analog signal related to the acceleration of the corresponding axis. The recommended 3.3 nF capacitor to complete the RC filter at each accelerometer output is included on the X, Y and Z outputs in the evaluation board. Each output already has an internal resistor. The RC filter is required to minimize clock noise that may be present from the switched capacitor filter circuit.

### Power Supply (Pins 5 and 6)

The power is supplied to the control IC through the  $V_{DD}$  and  $V_{SS}$  pins.  $V_{DD}$  is the positive supply and  $V_{SS}$  is the ground. The control IC operates from a single 3.3 V or 2.8 V power supply depending on the accelerometer. The MMA7360L and MMA7340L require a 3.3 V while the MMA7330L requires a 2.8V supply voltage. There is a main on/off switch to conserve power (SW1).

The evaluation boards have pads for interfacing to the power source. The pads on the side of the board also provide a means for connecting to the accelerometer analog output by soldering a wire from the evaluation board to another breadboard or system. The main on/off switch enables the power to the accelerometer and helps preserve battery life if a

battery is being used as the power source. SW1 must be set towards the "on" position for the accelerometer to function.

### Sleep Mode Function (Pin 7)

This 3 axis accelerometer provides a sleep mode that is ideal for a battery powered products. Sleep mode is active low. Therefore, when sleep mode is active, the device outputs are turned off, providing significant reduction of operating current. A low input signal on pin 7 will place the device in this mode and reduce the current to  $3\mu A$ . For lower power consumption, it is recommended to set the g-Select to the lower g- mode. By placing a high input on pin 7, the device will resume the normal mode of operation. This is selectable on the evaluation board using either the input/output sleep mode pad or the dip switch (SW2). Note: the main on/off switch (SW1) must remain on for sleep mode to be operable.

### Free Fall Functionality (Pin 9)

Pin 9 is used to detect freefall of the accelerometer. The output from this pin will go high when the outputs from X, Y and Z become 0-g. This is very useful for various applications as discussed in some of the previous examples. Pin 9 is a N/C pin on the MMA7330L and the MMA7340L.

## g-Select Dipswitch Setting (Pin 10)

The g-Select (pin 10) allows for the selection between two sensitivities present in the device. The dipswitch (SW2) allows for the choice of two different ranges of acceleration. By adjusting the dipswitch the device internal gain will be changed allowing it to function with a 1.5g or 6g sensitivity for the MMA7360L as shown in Table 2. The corresponding g-ranges for the MMA7340L and the MMA7330L are shown in Table 3 and Table 4 respectively. This feature is ideal when a product has applications requiring different sensitivities for optimum performance. The sensitivity can be changed at anytime during the operation of the product. Another option available is to have the g-Select pin left unconnected for applications requiring only one sensitivity, as the device has an internal pull-down to keep it at that sensitivity.

**Table 2. g-Select Pin 10 Descriptions MMA7360L**

| g-Select | g-Range | Sensitivity |
|----------|---------|-------------|
| 0        | 1.5g    | 800 mV/g    |
| 1        | 6g      | 206 mV/g    |

0g Output = 1.65 V,  $V_{DD} = 3.30$  V

**Table 3. g-Select Pin 10 Descriptions MMA7340L**

| g-Select | g-Range | Sensitivity |
|----------|---------|-------------|
| 0        | 3g      | 440 mV/g    |
| 1        | 11g     | 117.8 mV/g  |

0g Output = 1.65 V,  $V_{DD} = 3.30$  V

**Table 4. g-Select Pin 10 Descriptions MMA7330L**

| g-Select | g-Range | Sensitivity |
|----------|---------|-------------|
| 0        | 4g      | 308 mV/g    |
| 1        | 12g     | 83.6 mV/g   |

0g Output = 1.40 V,  $V_{DD} = 2.80$  V

## Self Test (Pin 13)

Pin 13 is used for putting the accelerometer into a self test mode. When this pin is activated using SW3 the actuator in the g-cell will move and the corresponding Voltage output will change by +1g. A logic high signal into this input sets the device in self test mode. The 0g-Detect output can be verified with the self test. If the board is placed upside down in the X-Y plane ( $X = 0g$ ,  $Y = 0g$ ,  $Z = -1g$ ). Then the self test can be activated, causing the z output to change to 0g. When all X, Y and Z outputs are 0g a high signal is sent to the 0g-Detect output pin. This verifies the self test and the freefall protection functionality.

## QUICK START GUIDE: HOW TO USE THE EVALUATION BOARD

1. Connect the external power source to the Evaluation Board. The 3.3V/2.8V input is connected to the + (V<sub>DD</sub>) and Gnd (V<sub>SS</sub>) using the solder pads.
2. Turn the side on/off switch into the “on” position as shown in Figure 4. The on/off switch provides power to the accelerometer and helps preserve battery life if a battery is being used as the power source. Therefore SW1 must be set toward the “on” position for the accelerometer to function.
3. Using a thin pointed tool turn the sleep mode dipswitch (SW2) to the “on” position as shown in Figure 4, or you can also power the sleep mode using the solder pad available. This enables the device. A low signal (0) will bring the board into sleep mode which puts it in a power saving mode. In this state there will be no X, Y or Z outputs on these output solder pads. For normal device operation though the sleep mode must be in the “on” position.
4. Connect the X, Y and Z outputs to an oscilloscope to view the outputs, or you can also solder these pads to a microcontroller or any other measuring device.
5. The evaluation board has pads for interfacing to a 3.3V/2.8V power source or battery. The pads on the side of the board also provide a means for connecting the accelerometer analog output by soldering a wire from the evaluation board to another breadboard or system.
6. The g-Select is shown in Figure 4 (SW2) in the lower of the two possible g-modes. You can also use the solder pad “G\_S” to access and change the g-mode.
7. The “FF” solder pad will output a high signal when the device has detected that X, Y and Z accelerations are

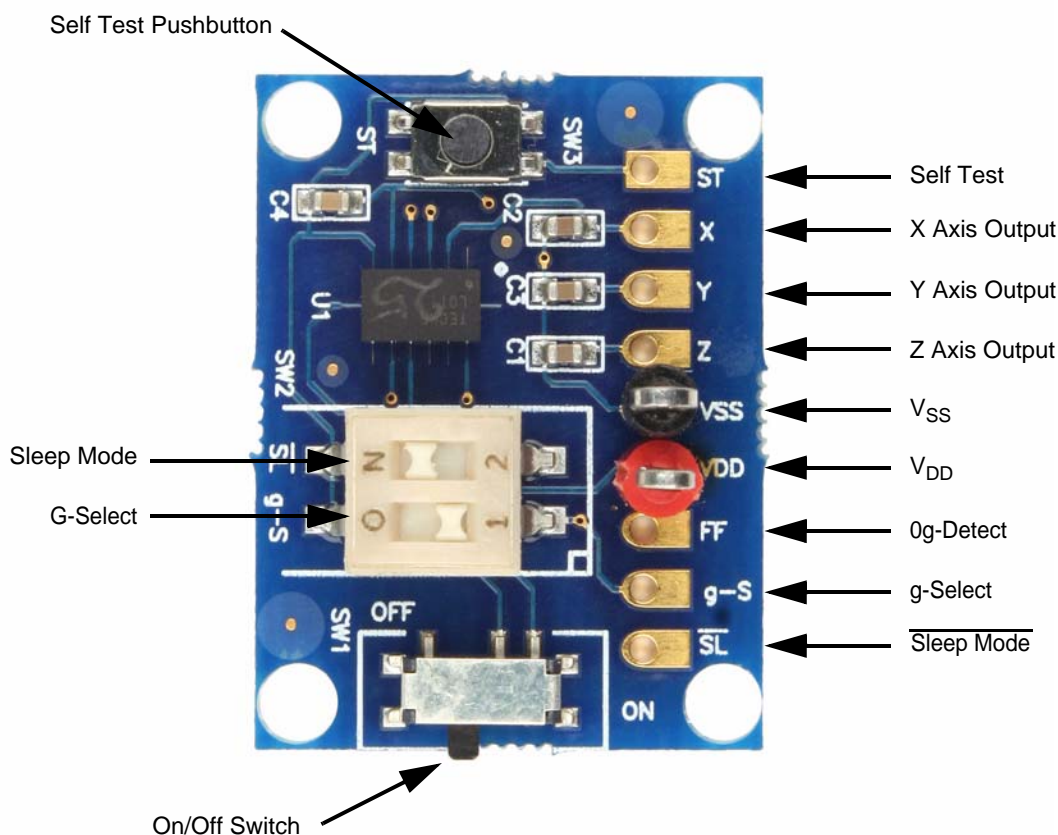

Figure 4. Evaluation Board Components

## **How to Reach Us:**

### **Home Page:**

[www.freescale.com](http://www.freescale.com)

### **Web Support:**

<http://www.freescale.com/support>

### **USA/Europe or Locations Not Listed:**

Freescale Semiconductor, Inc.  
Technical Information Center, EL516  
2100 East Elliot Road  
Tempe, Arizona 85284  
+1-800-521-6274 or +1-480-768-2130  
[www.freescale.com/support](http://www.freescale.com/support)

### **Europe, Middle East, and Africa:**

Freescale Halbleiter Deutschland GmbH  
Technical Information Center  
Schatzbogen 7  
81829 Muenchen, Germany  
+44 1296 380 456 (English)  
+46 8 52200080 (English)  
+49 89 92103 559 (German)  
+33 1 69 35 48 48 (French)  
[www.freescale.com/support](http://www.freescale.com/support)

### **Japan:**

Freescale Semiconductor Japan Ltd.  
Headquarters  
ARCO Tower 15F  
1-8-1, Shimo-Meguro, Meguro-ku,  
Tokyo 153-0064  
Japan  
0120 191014 or +81 3 5437 9125  
[support.japan@freescale.com](mailto:support.japan@freescale.com)

### **Asia/Pacific:**

Freescale Semiconductor Hong Kong Ltd.  
Technical Information Center  
2 Dai King Street  
Tai Po Industrial Estate  
Tai Po, N.T., Hong Kong  
+800 2666 8080  
[support.asia@freescale.com](mailto:support.asia@freescale.com)

### **For Literature Requests Only:**

Freescale Semiconductor Literature Distribution Center  
P.O. Box 5405  
Denver, Colorado 80217  
1-800-441-2447 or 303-675-2140  
Fax: 303-675-2150  
[LDCForFreescaleSemiconductor@hibbertgroup.com](mailto:LDCForFreescaleSemiconductor@hibbertgroup.com)

Information in this document is provided solely to enable system and software implementers to use Freescale Semiconductor products. There are no express or implied copyright licenses granted hereunder to design or fabricate any integrated circuits or integrated circuits based on the information in this document.

Freescale Semiconductor reserves the right to make changes without further notice to any products herein. Freescale Semiconductor makes no warranty, representation or guarantee regarding the suitability of its products for any particular purpose, nor does Freescale Semiconductor assume any liability arising out of the application or use of any product or circuit, and specifically disclaims any and all liability, including without limitation consequential or incidental damages. "Typical" parameters that may be provided in Freescale Semiconductor data sheets and/or specifications can and do vary in different applications and actual performance may vary over time. All operating parameters, including "Typicals", must be validated for each customer application by customer's technical experts. Freescale Semiconductor does not convey any license under its patent rights nor the rights of others. Freescale Semiconductor products are not designed, intended, or authorized for use as components in systems intended for surgical implant into the body, or other applications intended to support or sustain life, or for any other application in which the failure of the Freescale Semiconductor product could create a situation where personal injury or death may occur. Should Buyer purchase or use Freescale Semiconductor products for any such unintended or unauthorized application, Buyer shall indemnify and hold Freescale Semiconductor and its officers, employees, subsidiaries, affiliates, and distributors harmless against all claims, costs, damages, and expenses, and reasonable attorney fees arising out of, directly or indirectly, any claim of personal injury or death associated with such unintended or unauthorized use, even if such claim alleges that Freescale Semiconductor was negligent regarding the design or manufacture of the part.

Freescale™ and the Freescale logo are trademarks of Freescale Semiconductor, Inc. All other product or service names are the property of their respective owners.

© Freescale Semiconductor, Inc. 2007. All rights reserved.

