

Opto Interrupter ITR9606-F

Features

- Fast response time
- High analytic
- Cut-off visible wavelength $\lambda_p=940\text{nm}$
- High sensitivity
- Pb free
- This product itself will remain within RoHS compliant version

Description

- The ITR9606-F consist of an infrared emitting diode and an NPN silicon phototransistor, encased side-by-side on converging optical axis in a black thermoplastic housing,
- The phototransistor receives radiation from the IRED only .This is the normal situation.
- But when an object is in between , phototransistor could not receives the radiation.
- For additional component information , please refer to IR928-6C-F and PT928-6C-F

Applications

- Mouse Copier
- Switch Scanner
- Floppy disk driver
- Non-contact Switching
- For Direct Board

Device Selection Guide

Chip Materials	Lens Color
GaAIAs	Water clear
Silicon	Water clear

Absolute Maximum Ratings (Ta=25 °C)

Parameter		Symbol	Ratings	Unit
Input	Power Dissipation at(or below) 25 °C Free Air Temperature	Pd	75	mW
	Reverse Voltage	V _R	5	V
	Forward Current	I _F	50	mA
	Peak Forward Current (*1) Pulse width 100µs, Duty cycle=1%	I _{FP}	1	A
Output	Collector Power Dissipation	Pd	75	mW
	Collector Current	I _C	20	mA
	Collector-Emitter Voltage	B V _{CEO}	30	V
	Emitter-Collector Voltage	B V _{ECO}	5	V
Operating Temperature		Topr	-25~+85	
Storage Temperature		Tstg	-40~+85	
Lead Soldering Temperature (*2) (1/16 inch form body for 5 seconds)		Tsol	260	

(*1) $t_w=100 \mu\text{sec.}$, $T=10 \text{ msec.}$ (*2) $t=5 \text{ Sec}$

Electro-Optical Characteristics (Ta=25)

Parameter		Symbol	Min.	Typ.	Max.	Unit	Conditions
Input	Forward Voltage	V_F	---	1.2	1.5	V	$I_F=20\text{mA}$
	Reverse Current	I_R	---	---	10	μA	$V_R=5\text{V}$
	Peak Wavelength	λ_P	---	940	---	nm	$I_F=20\text{mA}$
	View Angle	$2\theta_{1/2}$	---	60	---	Deg	$I_F=20\text{mA}$
Output	Dark C urrent	I_{CEO}	---	---	100	nA	$V_{CE}=20\text{V}, E_e=0\text{mW}/\text{cm}^2$
	C-E Saturation Voltage	$V_{CE(\text{sat})}$	---	---	0.4	V	$I_C=2\text{mA}$ $E_e=1\text{mW}/\text{cm}^2$
Transfer Characteristics	Collect Current	$I_C(\text{ON})$	0.5	---	10	mA	$V_{CE}=5\text{V}$ $I_F=20\text{mA}$
	Rise time	t_r	---	15	---	μsec	$V_{CE}=5\text{V}$ $I_C=1\text{mA}$ $R_L=1\text{K}\Omega$
	Fall time	t_f	---	15	---	μsec	



Typical Electrical/Optical/Characteristics Curves for IR

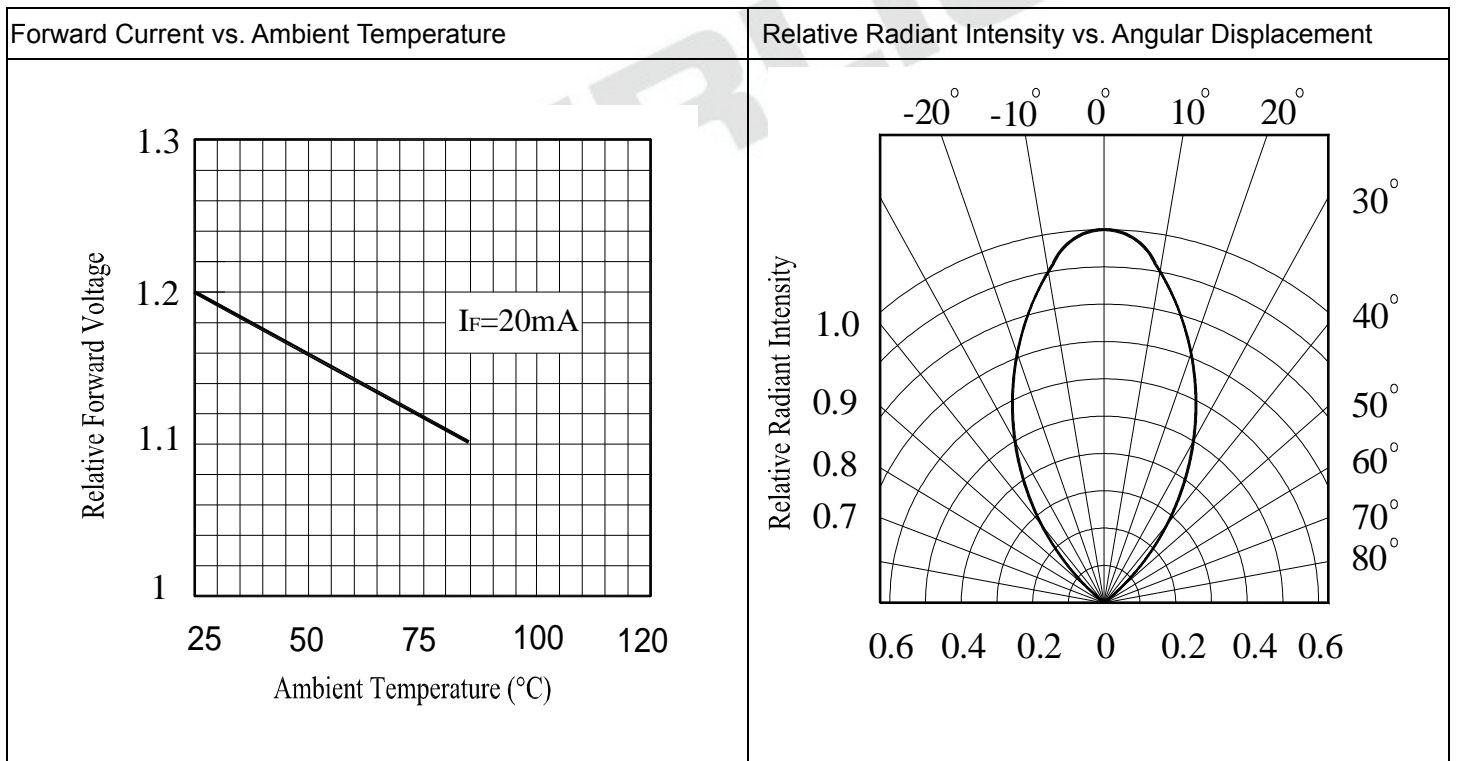
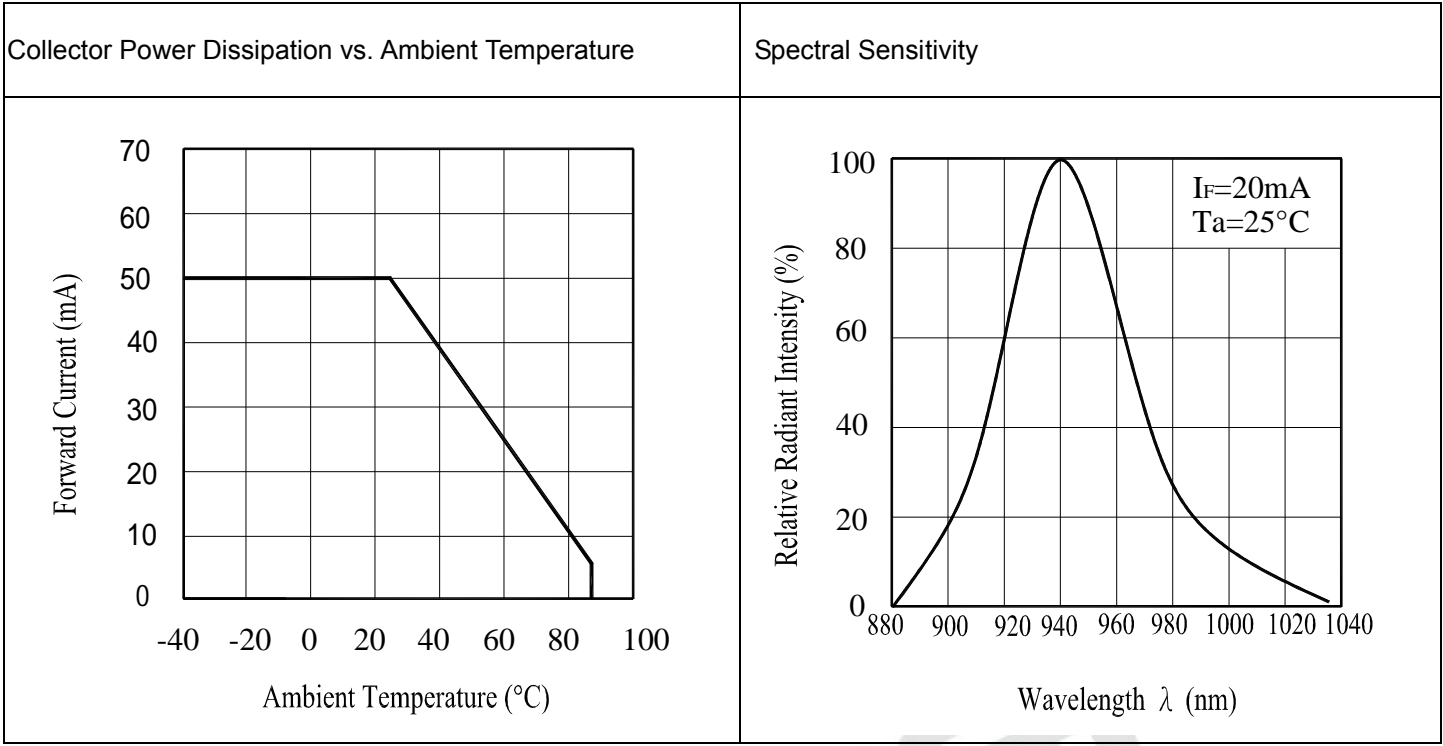

Typical Electrical/Optical/Characteristics Curves for PT

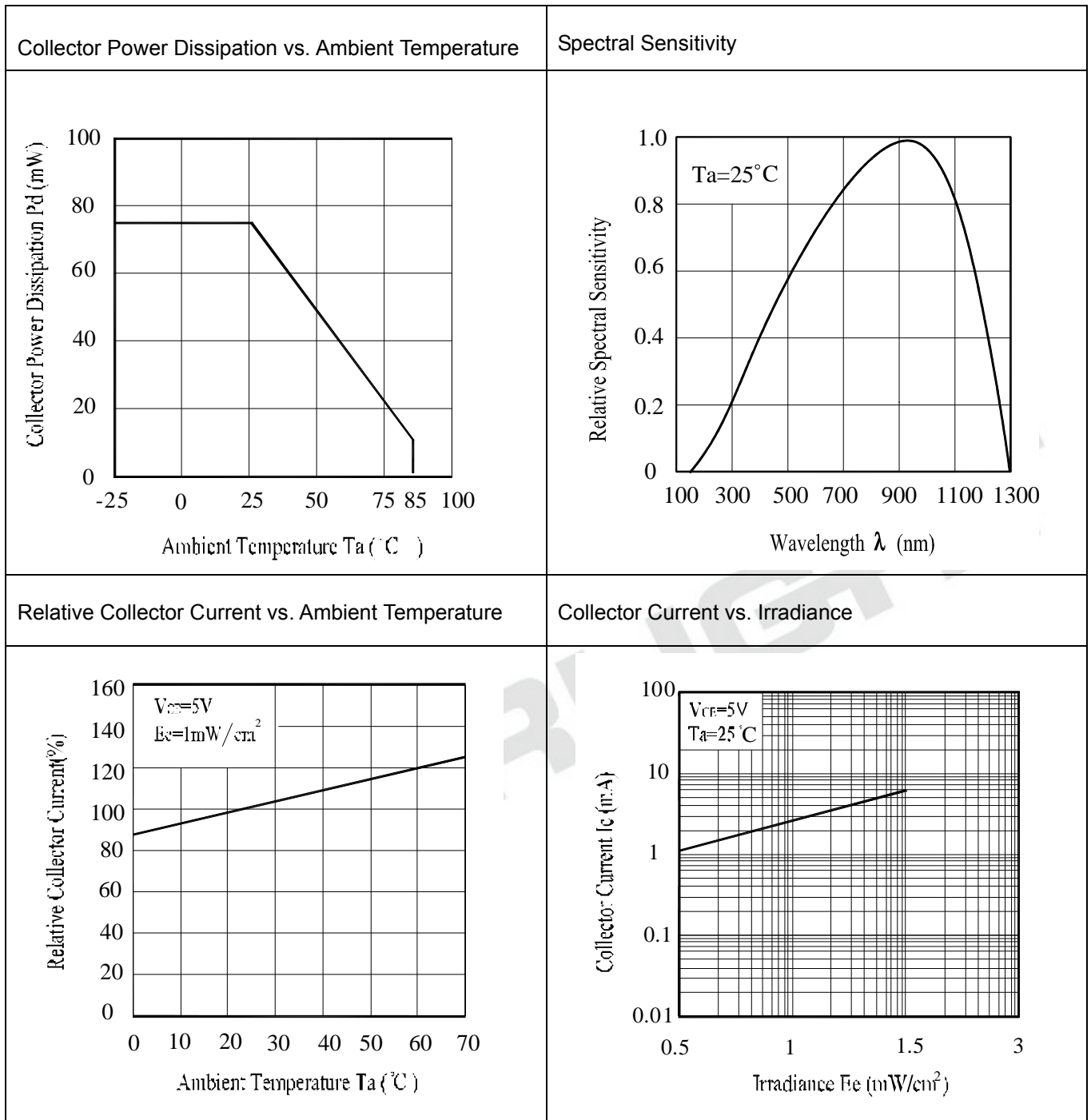

Collector Dark Current vs. Ambient Temperature

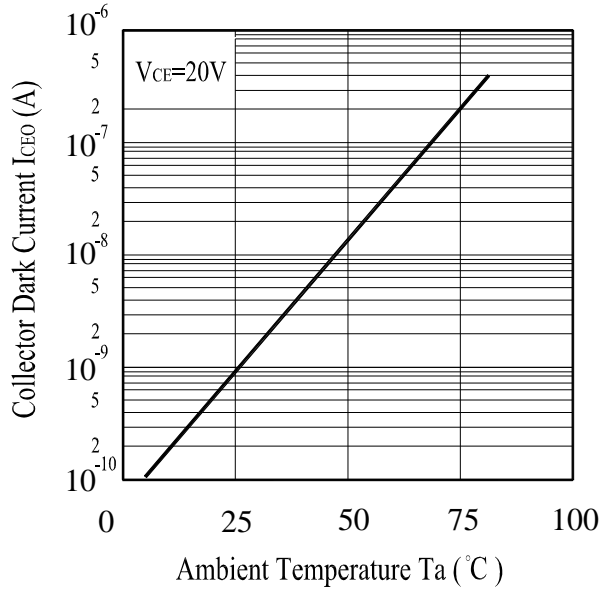

Collector Current vs. Collector-Emitter Voltage

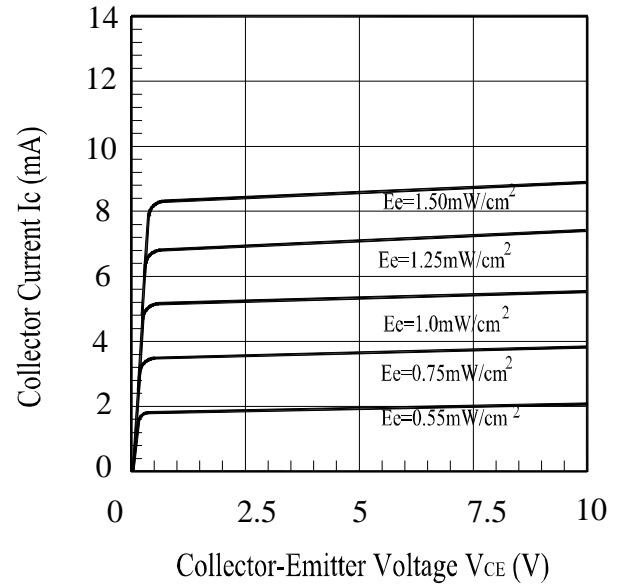

Package Dimension

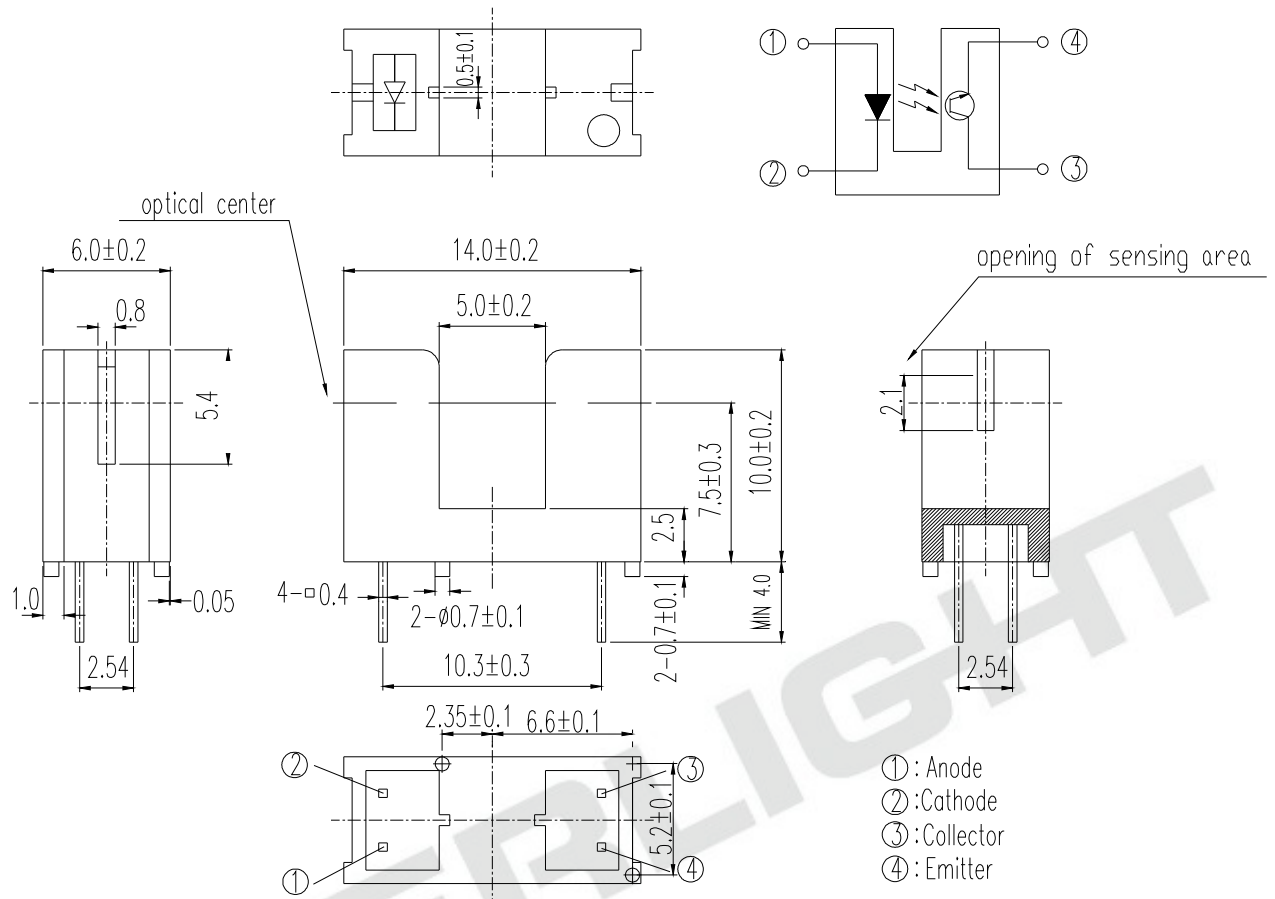

Note: Tolerances unless dimensions ± 0.25 mm

Packing Quantity Specification

1. 35PCS/1Tube, 100Tube/1Box
2. 4Boxes/1Carton

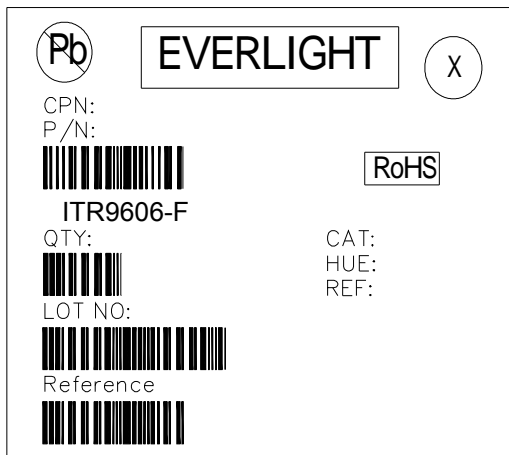
Label Form Specification

- CPN: Customer's Product Number
- P/N: Product Number
- QTY: Packing Quantity
- CAT: Luminous Intensity Rank
- HUE: Dom. Wavelength Rank
- REF: Forward Voltage Rank
- LOT No: Lot Number
- X: Month
- Reference: Identify Label Number

Notes

1. Above specification may be changed without notice. EVERLIGHT will reserve authority on material change for above specification.
2. When using this product, please observe the absolute maximum ratings and the instruction for using outlined in these specification sheets. EVERLIGHT assumes no responsibility for any damage resulting from use of the product which does not comply with the absolute maximum ratings and the instructions included in these specification sheets.
3. These specification sheets include materials protected under copyright of EVERLIGHT corporation. Please don't reproduce or cause anyone to reproduce them without EVERLIGHT's consent.