



Unidirectional Measurement Current-Shunt Monitor with Dual Comparators

FEATURES

- **COMPLETE CURRENT SENSE SOLUTION**
- **DUAL COMPARATORS:**
 - Comparator 1 with Latch
 - Comparator 2 with Optional Delay
- **COMMON-MODE RANGE: –16V to +80V**
- **HIGH ACCURACY: 3.5% (max) Over Temperature**
- **BANDWIDTH: 500kHz**
- **QUIESCENT CURRENT: 1.8mA**
- **PACKAGES: SO-14, TSSOP-14, MSOP-10**

APPLICATIONS

- **NOTEBOOK COMPUTERS**
- **CELL PHONES**
- **TELECOM EQUIPMENT**
- **AUTOMOTIVE**
- **POWER MANAGEMENT**
- **BATTERY CHARGERS**
- **WELDING EQUIPMENT**

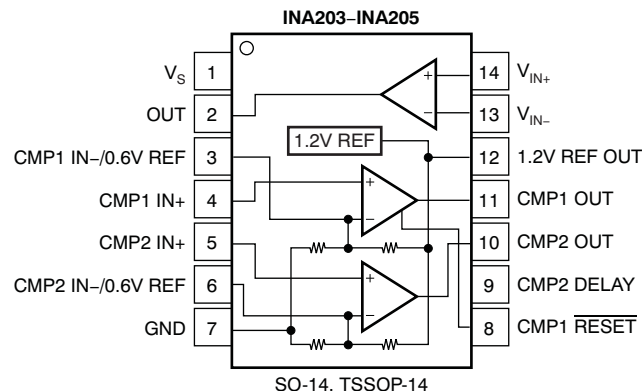

DESCRIPTION

The INA203, INA204, and INA205 are a family of unidirectional current-shunt monitors with voltage output, dual comparators, and voltage reference. The INA203, INA204, and INA205 can sense drops across shunts at common-mode voltages from –16V to +80V. The INA203, INA204, and INA205 are available with three output voltage scales: 20V/V, 50V/V, and 100V/V, with up to 500kHz bandwidth.

The INA203, INA204, and INA205 also incorporate two open-drain comparators with internal 0.6V references. On 14-pin versions, the comparator references can be overridden by external inputs. Comparator 1 includes a latching capability, and Comparator 2 has a user-programmable delay. 14-pin versions also provide a 1.2V reference output.

The INA203, INA204, and INA205 operate from a single +2.7V to +18V supply. They are specified over the extended operating temperature range of –40°C to +125°C.

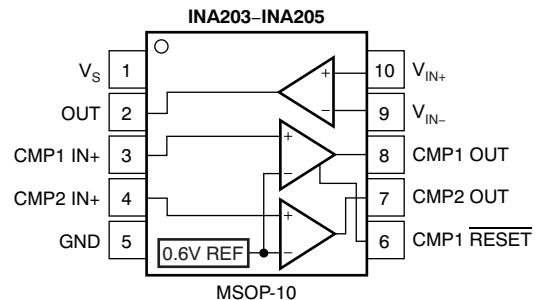

DEVICE	GAIN
INA203	20V/V
INA204	50V/V
INA205	100V/V

RELATED PRODUCTS

FEATURES	PRODUCT
Variant of INA203–INA205 Comparator 2 polarity	INA206–INA208
Current-shunt monitor with single Comparator and V_{REF}	INA200–INA202
Current-shunt monitor only	INA193–INA198
Current-shunt monitor with split stages for filter options	INA270–INA271



Please be aware that an important notice concerning availability, standard warranty, and use in critical applications of Texas Instruments semiconductor products and disclaimers thereto appears at the end of this data sheet.

All trademarks are the property of their respective owners.



This integrated circuit can be damaged by ESD. Texas Instruments recommends that all integrated circuits be handled with appropriate precautions. Failure to observe proper handling and installation procedures can cause damage.

ESD damage can range from subtle performance degradation to complete device failure. Precision integrated circuits may be more susceptible to damage because very small parametric changes could cause the device not to meet its published specifications.

ORDERING INFORMATION⁽¹⁾

PRODUCT	GAIN	PACKAGE-LEAD	PACKAGE DESIGNATOR	PACKAGE MARKING	1.2V REF OUT	EXTERNAL COMP1 AND COMP2 REF INPUTS	INTERNAL COMP1 AND COMP2 0.6V REF	COMP2 DELAY PIN
INA203	20V/V	SO-14	D	INA203A	X	X	X	X
		MSOP-10	DGS	BQN			X	
		TSSOP-14	PW	INA203A	X	X	X	X
INA204	50V/V	SO-14	D	INA204A	X	X	X	X
		MSOP-10	DGS	BQO			X	
		TSSOP-14	PW	INA204A	X	X	X	X
INA205	100V/V	SO-14	D	INA205A	X	X	X	X
		MSOP-10	DGS	BQP			X	
		TSSOP-14	PW	INA205A	X	X	X	X

(1) For the most current package and ordering information see the Package Option Addendum at the end of this document, or see the TI web site at www.ti.com.

ABSOLUTE MAXIMUM RATINGS⁽¹⁾

		INA203, INA204, INA205	UNIT
Supply Voltage, V+		18	V
Current-Shunt Monitor Analog Inputs, V _{IN+} and V _{IN-}	Differential (V _{IN+}) – (V _{IN-})	–18 to +18	V
	Common-Mode	–16 to +80	V
Comparator Analog Input and Reset Pins		GND – 0.3 to (V+) + 0.3	V
Analog Output, Out Pin		GND – 0.3 to (V+) + 0.3	V
Comparator Output, Out Pin		GND – 0.3 to 18	V
V _{REF} and CMP2 Delay Pin		GND – 0.3 to 10	V
Input Current Into Any Pin		5	mA
Operating Temperature		–55 to +150	°C
Storage Temperature		–65 to +150	°C
Junction Temperature		+150	°C
ESD Ratings	Human Body Model (HBM)	4000	V
	Charged Device Model (CDM)	500	V

(1) Stresses above these ratings may cause permanent damage. Exposure to absolute maximum conditions for extended periods may degrade device reliability. These are stress ratings only, and functional operation of the device at these or any other conditions beyond those specified is not supported.

ELECTRICAL CHARACTERISTICS: CURRENT-SHUNT MONITOR
Boldface limits apply over the specified temperature range: $T_A = -40^{\circ}\text{C}$ to $+125^{\circ}\text{C}$.

At $T_A = +25^{\circ}\text{C}$, $V_S = +12\text{V}$, $V_{CM} = +12\text{V}$, $V_{SENSE} = 100\text{mV}$, $R_L = 10\text{k}\Omega$ to GND, $R_{PULL-UP} = 5.1\text{k}\Omega$ each connected from CMP1 OUT and CMP2 OUT to V_S , and CMP1 IN+ = 1V and CMP2 IN– = GND, unless otherwise noted.

CURRENT-SHUNT MONITOR PARAMETERS		CONDITIONS	INA203, INA204, INA205			UNIT
			MIN	TYP	MAX	
INPUT						
Full-Scale Sense Input Voltage	V_{SENSE}	$V_{SENSE} = V_{IN+} - V_{IN-}$		0.15	$(V_S - 0.25)/\text{Gain}$	V
Common-Mode Input Range	V_{CM}		-16		80	V
Common-Mode Rejection Ratio	CMRR	$V_{CM} = -16\text{V}$ to $+80\text{V}$	80	100		dB
Over Temperature		$V_{CM} = +12\text{V}$ to $+80\text{V}$	100	123		dB
Offset Voltage, RTI ⁽¹⁾	V_{OS}			± 0.5	± 2.5	mV
+25°C to +125°C					± 3	mV
-40°C to +25°C					± 3.5	mV
vs Temperature	dV_{OS}/dT	T_{MIN} to T_{MAX}		5		$\mu\text{V}/^{\circ}\text{C}$
vs Power Supply	PSR	$V_{OUT} = 2\text{V}$, $V_{CM} = +18\text{V}$, 2.7V		2.5	100	$\mu\text{V}/\text{V}$
Input Bias Current, V_{IN-} Pin	I_B			± 9	± 16	μA
OUTPUT ($V_{SENSE} \geq 20\text{mV}$)						
Gain:	G					
INA203				20		V/V
INA204				50		V/V
INA205				100		V/V
Gain Error		$V_{SENSE} = 20\text{mV}$ to 100mV		± 0.2	± 1	%
Over Temperature		$V_{SENSE} = 20\text{mV}$ to 100mV			± 2	%
Total Output Error ⁽²⁾		$V_{SENSE} = 120\text{mV}$, $V_S = +16\text{V}$		± 0.75	± 2.2	%
Over Temperature		$V_{SENSE} = 120\text{mV}$, $V_S = +16\text{V}$			± 3.5	%
Nonlinearity Error ⁽³⁾		$V_{SENSE} = 20\text{mV}$ to 100mV		± 0.002		%
Output Impedance, Pin 2	R_O			1.5		Ω
Maximum Capacitive Load		No Sustained Oscillation		10		nF
OUTPUT ($V_{SENSE} < 20\text{mV}$)⁽⁴⁾						
INA203, INA204, INA205		$-16\text{V} \leq V_{CM} < 0\text{V}$		300		mV
INA203		$0\text{V} \leq V_{CM} \leq V_S$, $V_S = 5\text{V}$			0.4	V
INA204		$0\text{V} \leq V_{CM} \leq V_S$, $V_S = 5\text{V}$			1	V
INA205		$0\text{V} \leq V_{CM} \leq V_S$, $V_S = 5\text{V}$			2	V
INA203, INA204, INA205		$V_S < V_{CM} \leq 80\text{V}$		300		mV
VOLTAGE OUTPUT⁽⁵⁾						
Output Swing to the Positive Rail		$V_{IN-} = 11\text{V}$, $V_{IN+} = 12\text{V}$		$(V_+) - 0.15$	$(V_+) - 0.25$	V
Output Swing to GND⁽⁶⁾		$V_{IN-} = 0\text{V}$, $V_{IN+} = -0.5\text{V}$		$(V_{GND}) + 0.004$	$(V_{GND}) + 0.05$	V
FREQUENCY RESPONSE						
Bandwidth:	BW					
INA203		$C_{LOAD} = 5\text{pF}$		500		kHz
INA204		$C_{LOAD} = 5\text{pF}$		300		kHz
INA205		$C_{LOAD} = 5\text{pF}$		200		kHz
Phase Margin		$C_{LOAD} < 10\text{nF}$		40		Degrees
Slew Rate	SR			1		V/ μs
Settling Time (1%)		$V_{SENSE} = 10\text{mV}_{PP}$ to 100mV_{PP} , $C_{LOAD} = 5\text{pF}$		2		μs
NOISE, RTI						
Output Voltage Noise Density				40		nV/ $\sqrt{\text{Hz}}$

(1) Offset is extrapolated from measurements of the output at 20mV and 100mV V_{SENSE} .

(2) Total output error includes effects of gain error and V_{OS} .

(3) Linearity is best fit to a straight line.

(4) For details on this region of operation, see the [Accuracy Variations](#) section in the [Applications Information](#).

(5) See Typical Characteristic curve *Positive Output Voltage Swing vs Output Current* (Figure 8).

(6) Specified by design; not production tested.

ELECTRICAL CHARACTERISTICS: COMPARATOR

Boldface limits apply over the specified temperature range: $T_A = -40^{\circ}\text{C}$ to $+125^{\circ}\text{C}$.

At $T_A = +25^{\circ}\text{C}$, $V_S = +12\text{V}$, $V_{\text{CM}} = +12\text{V}$, $V_{\text{SENSE}} = 100\text{mV}$, $R_L = 10\text{k}\Omega$ to GND, and $R_{\text{PULL-UP}} = 5.1\text{k}\Omega$ each connected from CMP1 OUT and CMP2 OUT to V_S , unless otherwise noted.

COMPARATOR PARAMETERS	CONDITIONS	INA203, INA204, INA205			UNIT
		MIN	TYP	MAX	
OFFSET VOLTAGE					
Offset Voltage	Comparator Common-Mode Voltage = Threshold Voltage		2		mV
Offset Voltage Drift, Comparator 1			± 2		$\mu\text{V}/^{\circ}\text{C}$
Offset Voltage Drift, Comparator 2			+5.4		$\mu\text{V}/^{\circ}\text{C}$
Threshold	$T_A = +25^{\circ}\text{C}$	590	608	620	mV
Over Temperature		586		625	mV
Hysteresis ⁽¹⁾ , CMP1	$T_A = -40^{\circ}\text{C}$ to $+85^{\circ}\text{C}$		-8		mV
Hysteresis ⁽¹⁾ , CMP2	$T_A = -40^{\circ}\text{C}$ to $+85^{\circ}\text{C}$		8		mV
INPUT BIAS CURRENT⁽²⁾					
CMP1 IN+, CMP2 IN+			0.005	10	nA
vs Temperature				15	nA
INPUT IMPEDANCE					
Pins 3 and 6 (14-pin packages only)			10		k Ω
INPUT RANGE					
CMP1 IN+ and CMP2 IN+			0V to $V_S - 1.5\text{V}$		V
Pins 3 and 6 (14-pin packages only) ⁽³⁾			0V to $V_S - 1.5\text{V}$		V
OUTPUT					
Large-Signal Differential Voltage Gain	CMP V_{OUT} 1V to 4V, $R_L \geq 15\text{k}\Omega$ Connected to 5V		200		V/mV
High-Level Output Current	$V_{\text{ID}} = 0.4\text{V}$, $V_{\text{OH}} = V_S$		0.0001	1	μA
Low-Level Output Voltage	$V_{\text{ID}} = -0.6\text{V}$, $I_{\text{OL}} = 2.35\text{mA}$		220	300	mV
RESPONSE TIME⁽⁴⁾					
Comparator 1	R_L to 5V, $C_L = 15\text{pF}$, 100mV Input Step with 5mV Overdrive		1.3		μs
Comparator 2	R_L to 5V, $C_L = 15\text{pF}$, 100mV Input Step with 5mV Overdrive, C_{DELAY} Pin Open		1.3		μs
RESET					
RESET Threshold ⁽⁵⁾			1.1		V
Logic Input Impedance			2		M Ω
Minimum RESET Pulse Width			1.5		μs
RESET Propagation Delay			3		μs
Comparator 2 Delay Equation ⁽⁶⁾			$C_{\text{DELAY}} = t_d/5$		μF
Comparator 2 Delay	t_d	$C_{\text{DELAY}} = 0.1\mu\text{F}$	0.5		s

- (1) Hysteresis refers to the threshold (the threshold specification applies to a rising edge of a noninverting input) of a falling edge on the noninverting input of the comparator; refer to [Figure 1](#).
- (2) Specified by design; not production tested.
- (3) See the [Comparator Maximum Input Voltage Range](#) section in the [Applications Information](#).
- (4) The comparator response time specified is the interval between the input step function and the instant when the output crosses 1.4V.
- (5) The CMP1 RESET input has an internal 2M Ω (typical) pull-down. Leaving the CMP1 RESET open results in a LOW state, with transparent comparator operation.
- (6) The Comparator 2 delay applies to both rising and falling edges of the comparator output.

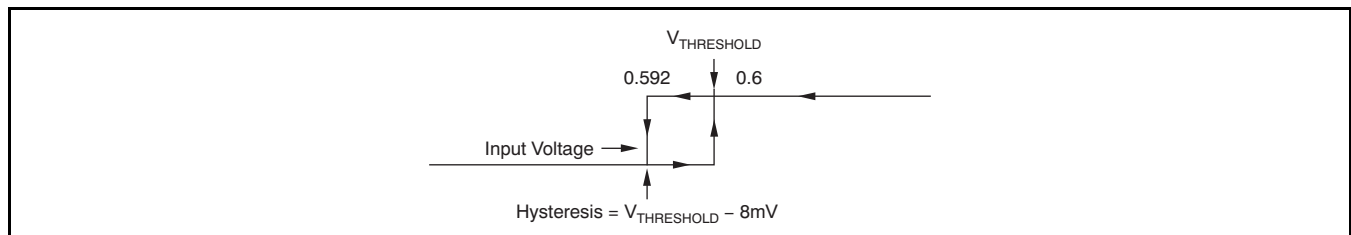

Figure 1. Comparator Hysteresis

ELECTRICAL CHARACTERISTICS: REFERENCE

Boldface limits apply over the specified temperature range: $T_A = -40^{\circ}\text{C}$ to $+125^{\circ}\text{C}$.

At $T_A = +25^{\circ}\text{C}$, $V_S = +12\text{V}$, $V_{CM} = +12\text{V}$, $V_{SENSE} = 100\text{mV}$, $R_L = 10\text{k}\Omega$ to GND, and $R_{PULL-UP} = 5.1\text{k}\Omega$ each connected from CMP1 OUT and CMP2 OUT to V_S , unless otherwise noted.

REFERENCE PARAMETERS	CONDITIONS	INA203, INA204, INA205			UNIT
		MIN	TYP	MAX	
REFERENCE VOLTAGE					
1.2V _{REFOUT} Output Voltage		1.188	1.2	1.212	V
Reference Drift	dV_{OUT}/dT $T_A = -40^{\circ}\text{C}$ to $+85^{\circ}\text{C}$		40	100	ppm/ $^{\circ}\text{C}$
0.6V _{REF} Output Voltage (Pins 3 and 6 of 14-pin packages only)			0.6		V
Reference Drift	dV_{OUT}/dT $T_A = -40^{\circ}\text{C}$ to $+85^{\circ}\text{C}$		40	100	ppm/ $^{\circ}\text{C}$
LOAD REGULATION	dV_{OUT}/dI_{LOAD}				
Sourcing	$0\text{mA} < I_{SOURCE} < 0.5\text{mA}$		0.4	2	mV/mA
Sinking	$0\text{mA} < I_{SINK} < 0.5\text{mA}$		0.4		mV/mA
LOAD CURRENT	I_{LOAD}		1		mA
LINE REGULATION	dV_{OUT}/dV_S $2.7\text{V} < V_S < 18\text{V}$		30		$\mu\text{V}/\text{V}$
CAPACITIVE LOAD					
Reference Output Maximum Capacitive Load	No Sustained Oscillations		10		nF
OUTPUT IMPEDANCE					
Pins 3 and 6 of 14-Pin Packages Only			10		k Ω

ELECTRICAL CHARACTERISTICS: GENERAL

Boldface limits apply over the specified temperature range: $T_A = -40^{\circ}\text{C}$ to $+125^{\circ}\text{C}$.

All specifications at $T_A = +25^{\circ}\text{C}$, $V_S = +12\text{V}$, $V_{CM} = +12\text{V}$, $V_{SENSE} = 100\text{mV}$, $R_L = 10\text{k}\Omega$ to GND, $R_{PULL-UP} = 5.1\text{k}\Omega$ each connected from CMP1 OUT and CMP2 OUT to V_S , and CMP1 IN+ = 1V and CMP2 IN- = GND, unless otherwise noted.

GENERAL PARAMETERS	CONDITIONS	INA203, INA204, INA205			UNIT
		MIN	TYP	MAX	
POWER SUPPLY					
Operating Power Supply	V_S	+2.7		+18	V
Quiescent Current	I_Q		1.8	2.2	mA
Over Temperature	$V_{OUT} = 2\text{V}$ $V_{SENSE} = 0\text{mV}$			2.8	mA
Comparator Power-On Reset Threshold ⁽¹⁾			1.5		V
TEMPERATURE					
Specified Temperature Range		-40		+125	$^{\circ}\text{C}$
Operating Temperature Range		-55		+150	$^{\circ}\text{C}$
Storage Temperature Range		-65		+150	$^{\circ}\text{C}$
Thermal Resistance	θ_{JA}				
MSOP-10 Surface-Mount			200		$^{\circ}\text{C}/\text{W}$
SO-14, TSSOP-14 Surface-Mount			150		$^{\circ}\text{C}/\text{W}$

- (1) The INA203, INA204, and INA205 are designed to power-up with the comparator in a defined reset state as long as CMP1 $\overline{\text{RESET}}$ is open or grounded. The comparator will be in reset as long as the power supply is below the voltage shown here. The comparator assumes a state based on the comparator input above this supply voltage. If CMP1 $\overline{\text{RESET}}$ is high at power-up, the comparator output comes up high and requires a reset to assume a low state, if appropriate.

TYPICAL CHARACTERISTICS

All specifications at $T_A = +25^\circ\text{C}$, $V_S = +12\text{V}$, $V_{CM} = +12\text{V}$, and $V_{SENSE} = 100\text{mV}$, unless otherwise noted.

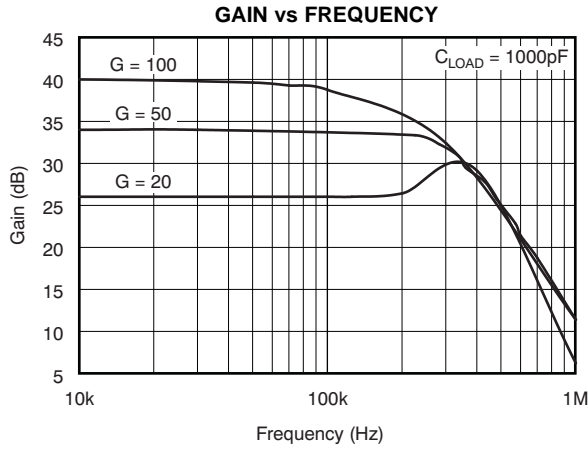

Figure 2.

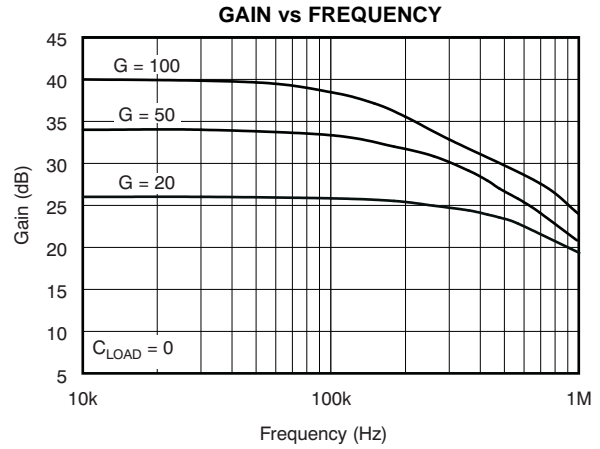

Figure 3.

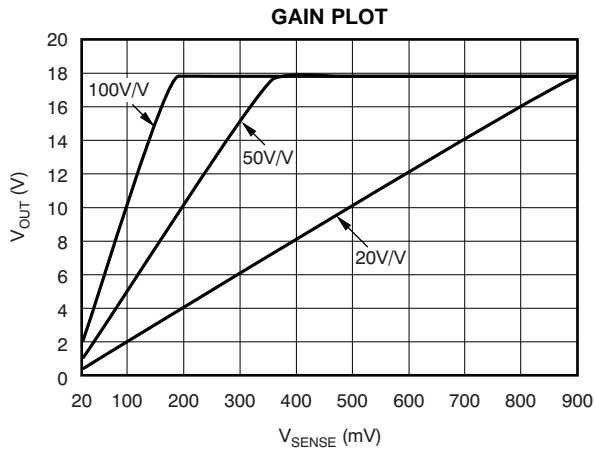

Figure 4.

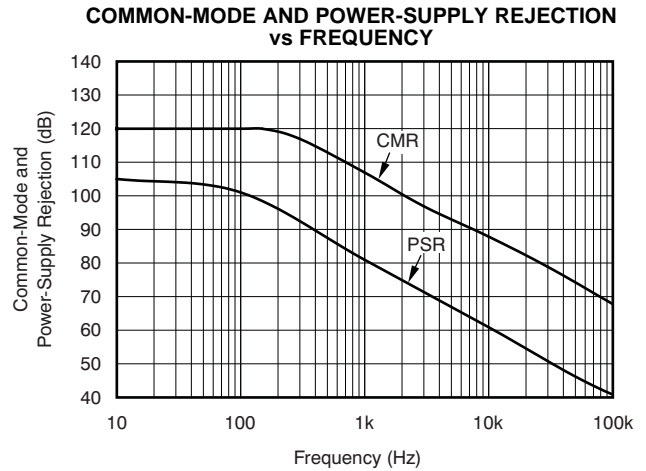

Figure 5.

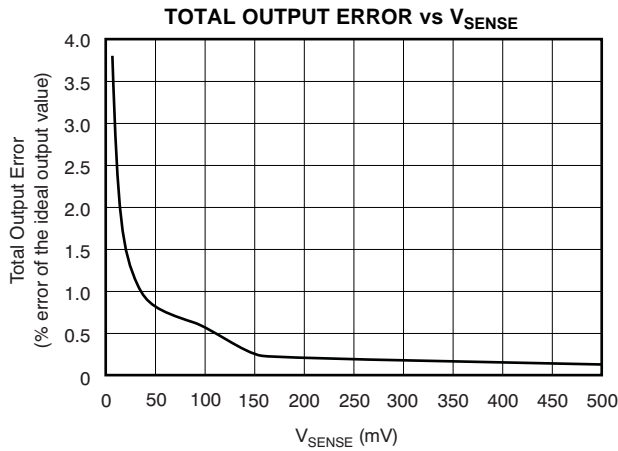

Figure 6.

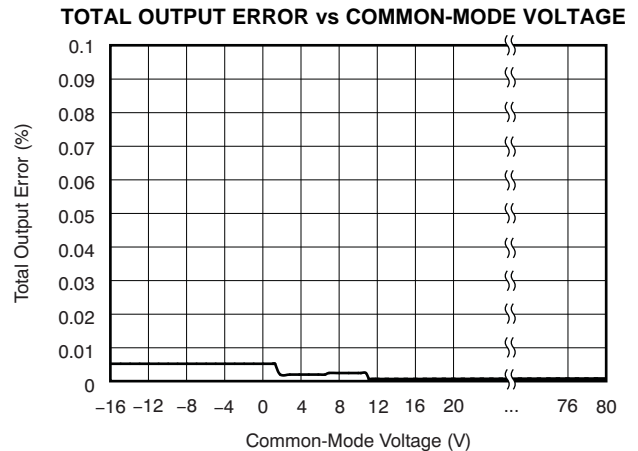

Figure 7.

TYPICAL CHARACTERISTICS (continued)

All specifications at $T_A = +25^\circ\text{C}$, $V_S = +12\text{V}$, $V_{CM} = +12\text{V}$, and $V_{SENSE} = 100\text{mV}$, unless otherwise noted.

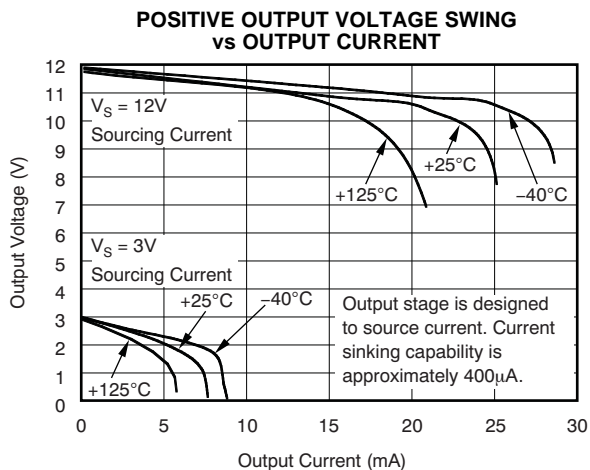

Figure 8.

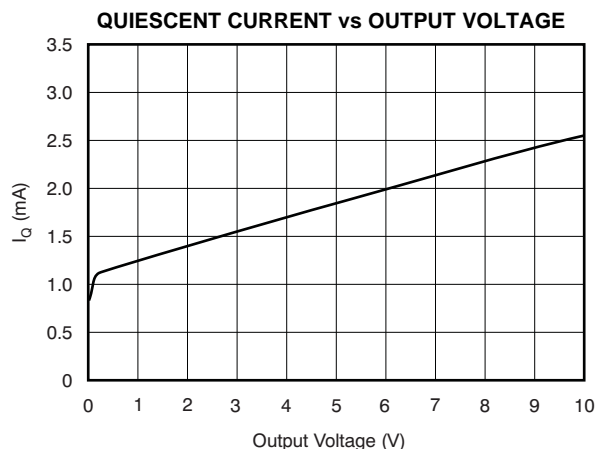

Figure 9.

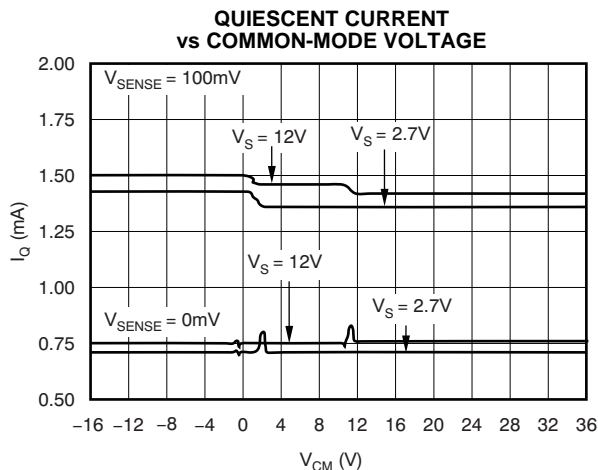

Figure 10.

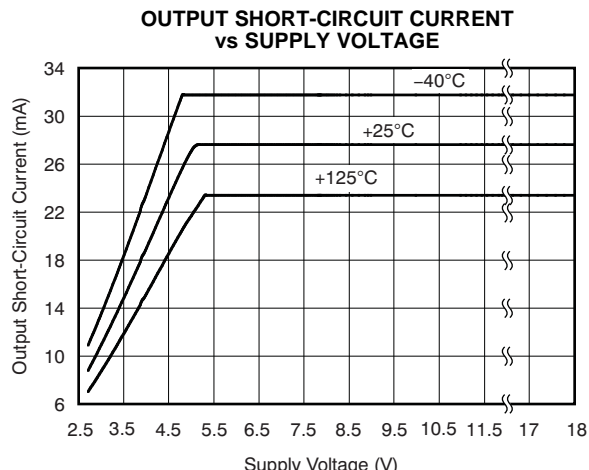

Figure 11.

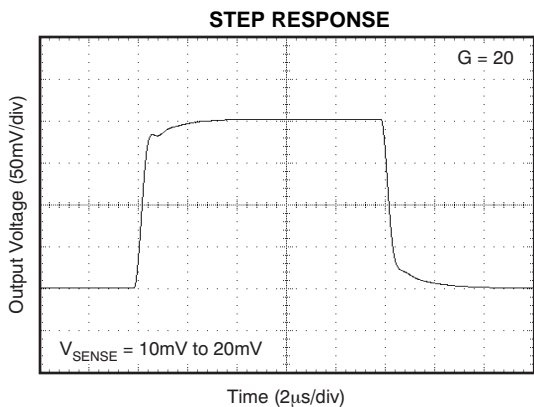

Figure 12.

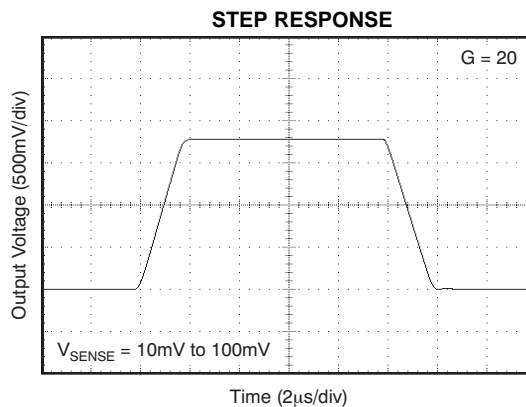

Figure 13.

TYPICAL CHARACTERISTICS (continued)

All specifications at $T_A = +25^\circ\text{C}$, $V_S = +12\text{V}$, $V_{CM} = +12\text{V}$, and $V_{SENSE} = 100\text{mV}$, unless otherwise noted.

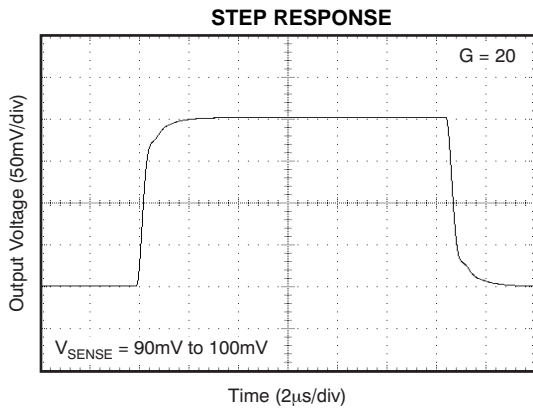

Figure 14.

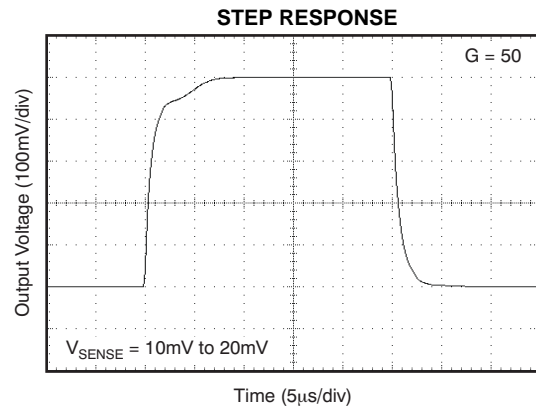

Figure 15.

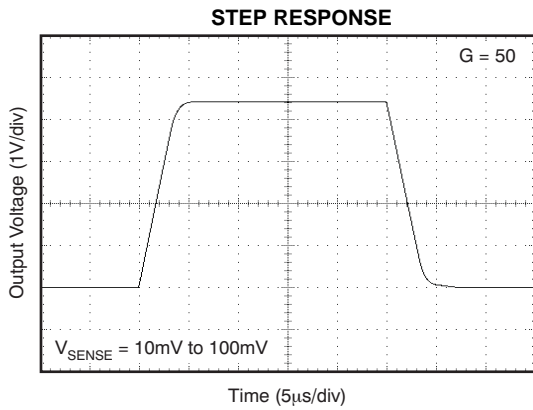

Figure 16.

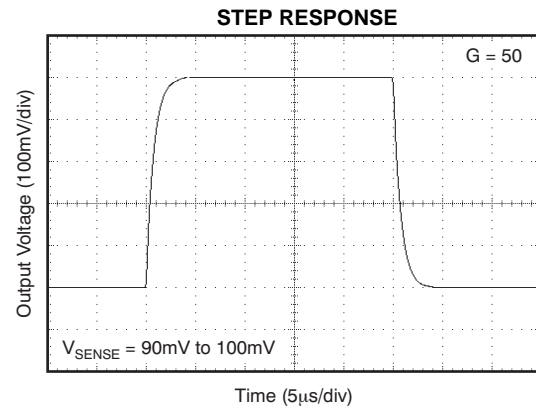

Figure 17.

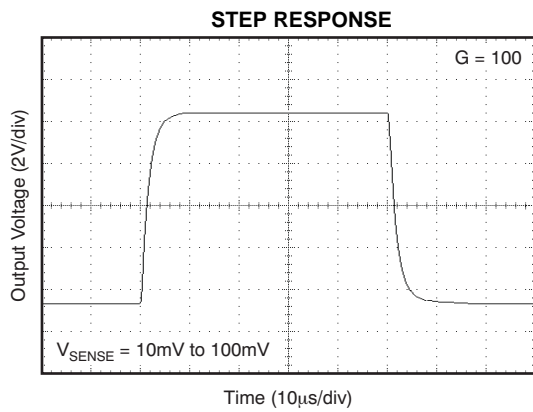

Figure 18.

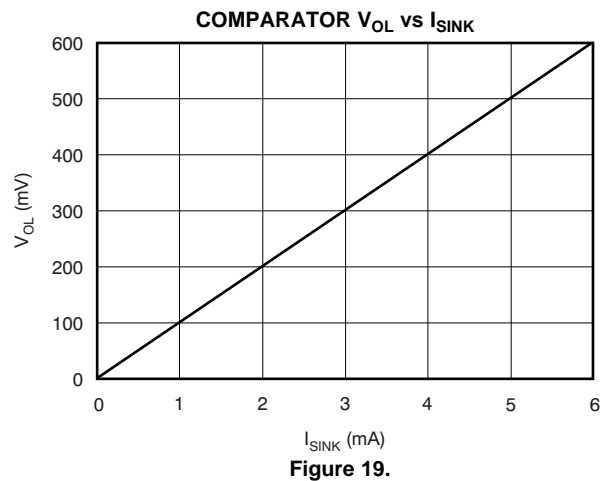

Figure 19.

TYPICAL CHARACTERISTICS (continued)

All specifications at $T_A = +25^\circ\text{C}$, $V_S = +12\text{V}$, $V_{CM} = +12\text{V}$, and $V_{SENSE} = 100\text{mV}$, unless otherwise noted.

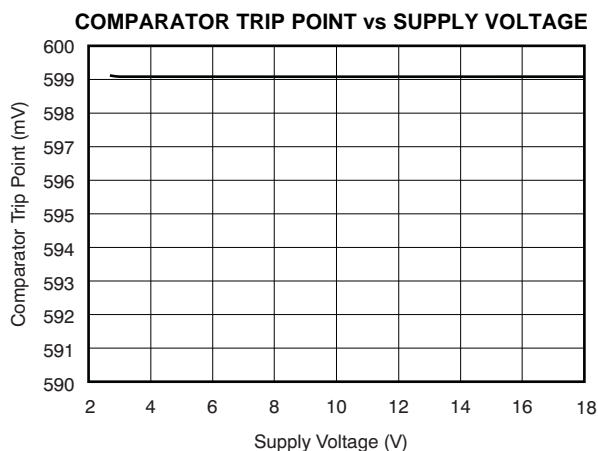

Figure 20.

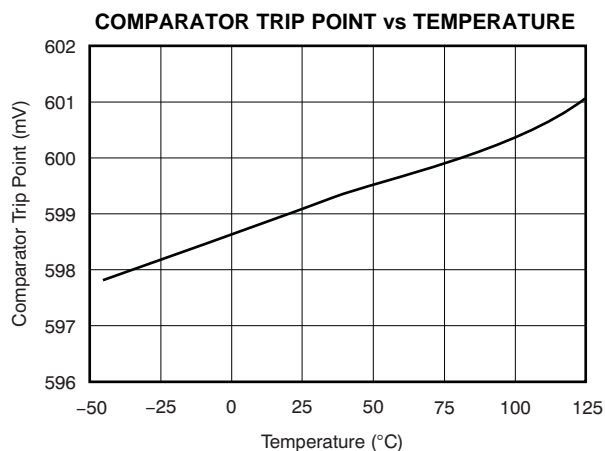

Figure 21.

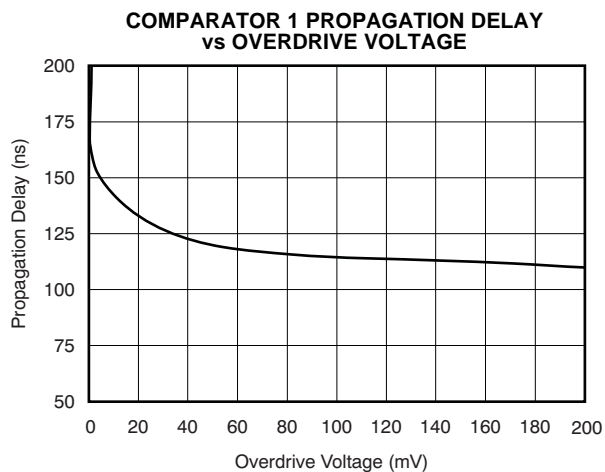

Figure 22.

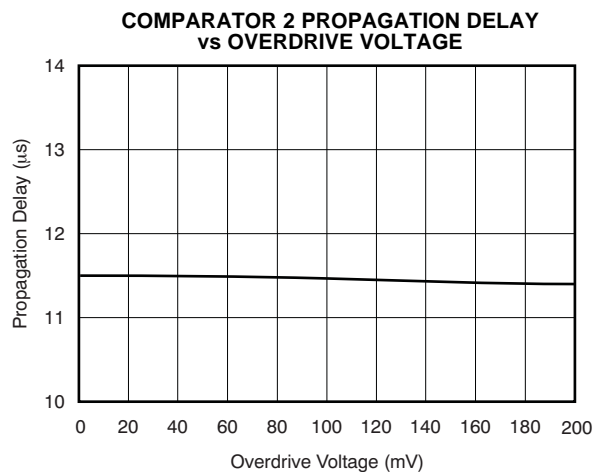

Figure 23.

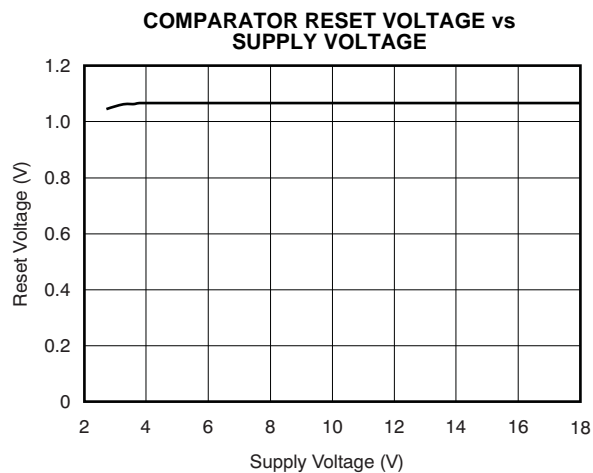

Figure 24.

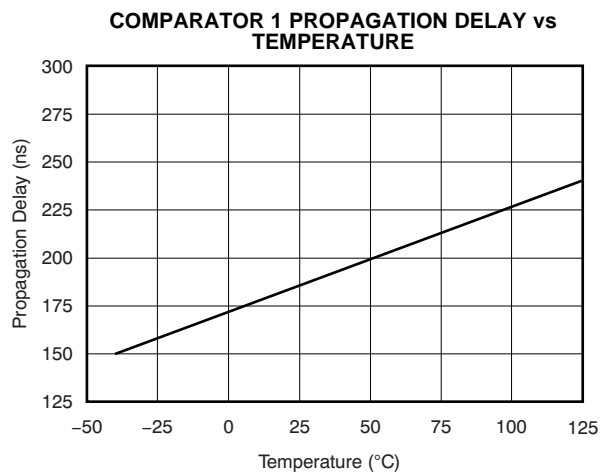

Figure 25.

TYPICAL CHARACTERISTICS (continued)

All specifications at $T_A = +25^\circ\text{C}$, $V_S = +12\text{V}$, $V_{CM} = +12\text{V}$, and $V_{SENSE} = 100\text{mV}$, unless otherwise noted.

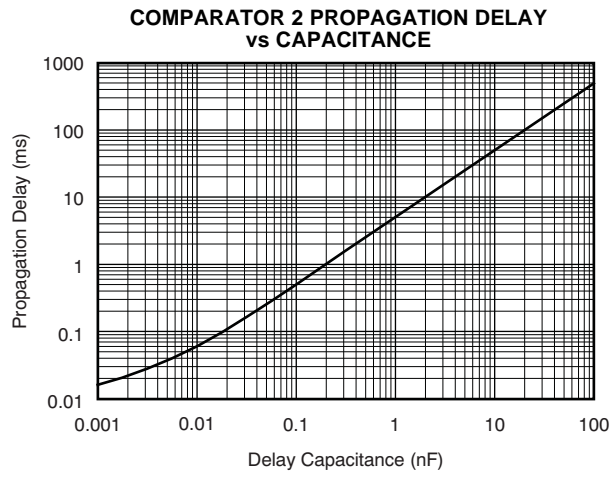

Figure 26.

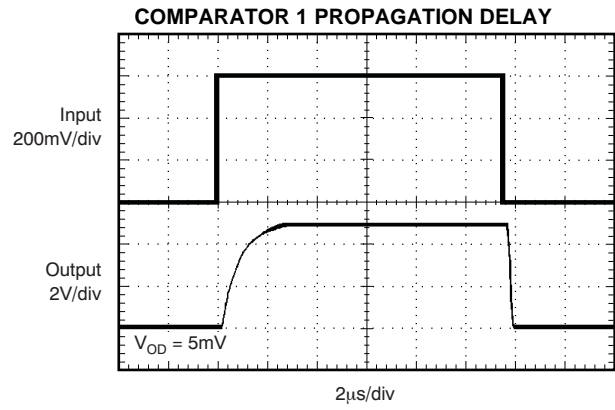

Figure 27.

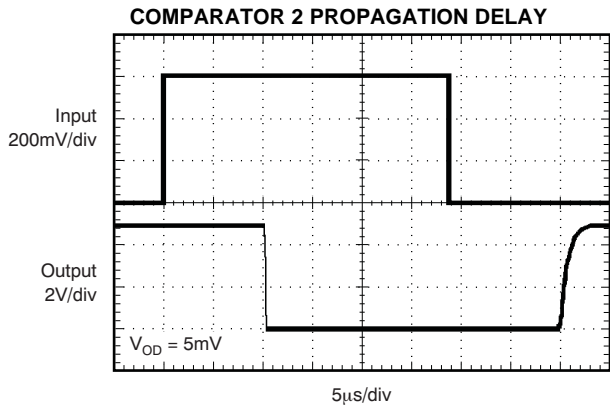

Figure 28.

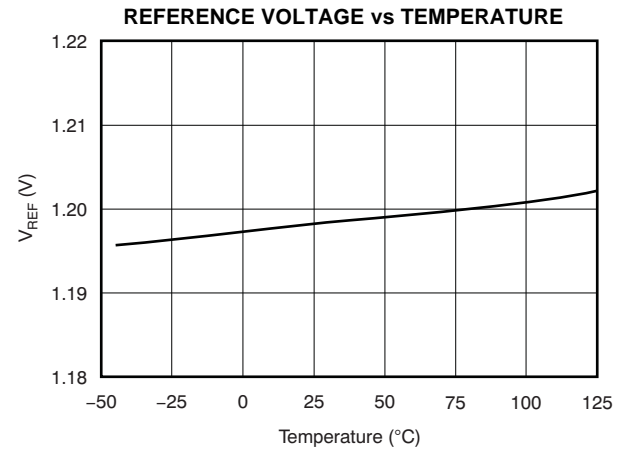

Figure 29.

APPLICATIONS INFORMATION

BASIC CONNECTIONS

Figure 30 shows the basic connections of the INA203, INA204, and INA205. The input pins, V_{IN+} and V_{IN-} , should be connected as closely as possible to the shunt resistor to minimize any resistance in series with the shunt resistance.

Power-supply bypass capacitors are required for stability. Applications with noisy or high-impedance power supplies may require additional decoupling capacitors to reject power-supply noise. Connect bypass capacitors close to the device pins.

POWER SUPPLY

The input circuitry of the INA203, INA204, and INA205 can accurately measure beyond the power-supply voltage, V_+ . For example, the V_+ power supply can be 5V, whereas the load power-supply voltage is up to +80V. The output voltage range of the OUT terminal, however, is limited by the voltages on the power-supply pin.

ACCURACY VARIATIONS AS A RESULT OF V_{SENSE} AND COMMON-MODE VOLTAGE

The accuracy of the INA203, INA204, and INA205 current shunt monitors is a function of two main variables: V_{SENSE} ($V_{IN+} - V_{IN-}$) and common-mode voltage, V_{CM} , relative to the supply voltage, V_S . V_{CM} is expressed as $(V_{IN+} + V_{IN-})/2$; however, in practice, V_{CM} is seen as the voltage at V_{IN+} because the voltage drop across V_{SENSE} is usually small.

This section addresses the accuracy of these specific operating regions:

- Normal Case 1: $V_{SENSE} \geq 20\text{mV}$, $V_{CM} \geq V_S$
- Normal Case 2: $V_{SENSE} \geq 20\text{mV}$, $V_{CM} < V_S$
- Low V_{SENSE} Case 1: $V_{SENSE} < 20\text{mV}$, $-16\text{V} \leq V_{CM} < 0$
- Low V_{SENSE} Case 2: $V_{SENSE} < 20\text{mV}$, $0\text{V} \leq V_{CM} \leq V_S$
- Low V_{SENSE} Case 3: $V_{SENSE} < 20\text{mV}$, $V_S < V_{CM} \leq 80\text{V}$

Normal Case 1: $V_{SENSE} \geq 20\text{mV}$, $V_{CM} \geq V_S$

This region of operation provides the highest accuracy. Here, the input offset voltage is characterized and measured using a two-step method. First, the gain is determined by Equation 1.

$$G = \frac{V_{OUT1} - V_{OUT2}}{100\text{mV} - 20\text{mV}} \quad (1)$$

where:

V_{OUT1} = Output Voltage with $V_{SENSE} = 100\text{mV}$

V_{OUT2} = Output Voltage with $V_{SENSE} = 20\text{mV}$

Then the offset voltage is measured at $V_{SENSE} = 100\text{mV}$ and referred to the input (RTI) of the current shunt monitor, as shown in Equation 2.

$$V_{OS\text{RTI}} (\text{Referred-To-Input}) = \left[\frac{V_{OUT1}}{G} \right] - 100\text{mV} \quad (2)$$

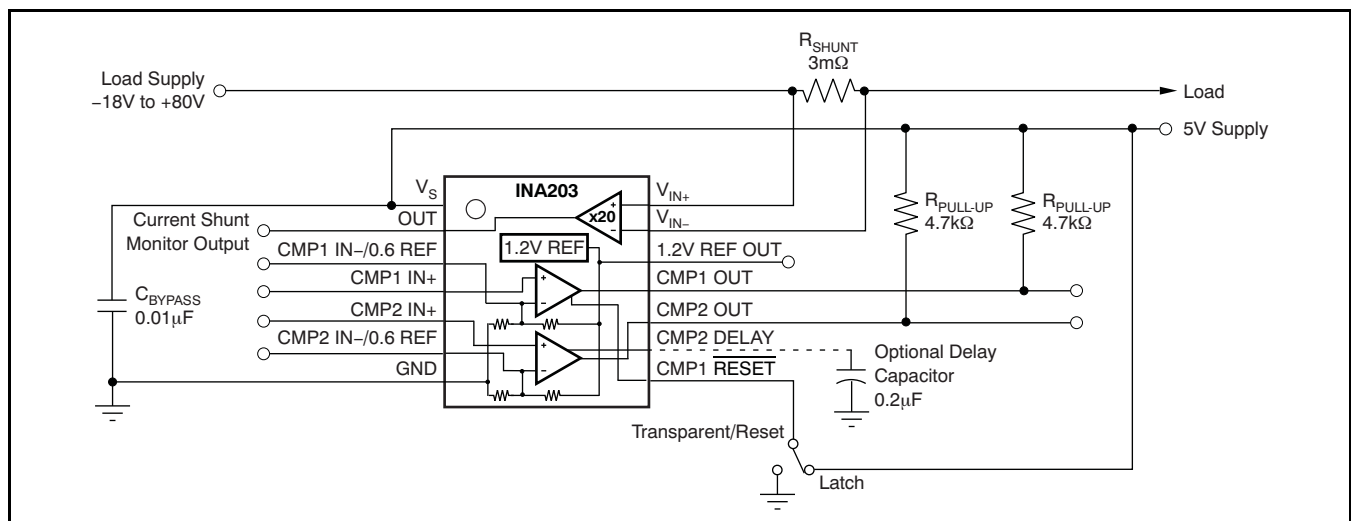

Figure 30. INA20x Basic Connection

In the [Typical Characteristics](#), the *Output Error vs Common-Mode Voltage* curve ([Figure 7](#)) shows the highest accuracy for this region of operation. In this plot, $V_S = 12V$; for $V_{CM} \geq 12V$, the output error is at its minimum. This case is also used to create the $V_{SENSE} \geq 20mV$ output specifications in the [Electrical Characteristics](#) table.

Normal Case 2: $V_{SENSE} \geq 20mV, V_{CM} < V_S$

This region of operation has slightly less accuracy than Normal Case 1 as a result of the common-mode operating area in which the part functions, as seen in the *Output Error vs Common-Mode Voltage* curve ([Figure 7](#)). As noted, for this graph $V_S = 12V$; for $V_{CM} < 12V$, the Output Error increases as V_{CM} becomes less than 12V, with a typical maximum error of 0.005% at the most negative $V_{CM} = -16V$.

Low V_{SENSE} Case 1:

$V_{SENSE} < 20mV, -16V \leq V_{CM} < 0$; and

Low V_{SENSE} Case 3:

$V_{SENSE} < 20mV, V_S < V_{CM} \leq 80V$

Although the INA203 family of devices are not designed for accurate operation in either of these regions, some applications are exposed to these conditions; for example, when monitoring power supplies that are switched on and off while V_S is still applied to the INA203, INA204, or INA205. It is important to know what the behavior of the devices will be in these regions.

As V_{SENSE} approaches 0mV, in these V_{CM} regions, the device output accuracy degrades. A larger-than-normal offset can appear at the current shunt monitor output with a typical maximum value of $V_{OUT} = 300mV$ for $V_{SENSE} = 0mV$. As V_{SENSE} approaches 20mV, V_{OUT} returns to the expected output value with accuracy as specified in the [Electrical Characteristics](#). [Figure 31](#) illustrates this effect using the INA205 (Gain = 100).

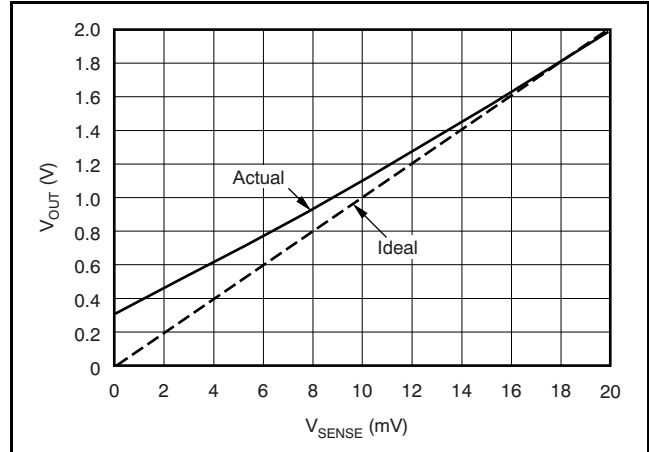

Figure 31. Example for Low V_{SENSE} Cases 1 and 3 (INA205, Gain = 100)

Low V_{SENSE} Case 2: $V_{SENSE} < 20mV, 0V \leq V_{CM} \leq V_S$

This region of operation is the least accurate for the INA203 family. To achieve the wide input common-mode voltage range, these devices use two op amp front ends in parallel. One op amp front end operates in the positive input common-mode voltage range, and the other in the negative input region. For this case, neither of these two internal amplifiers dominates and overall loop gain is very low. Within this region, V_{OUT} approaches voltages close to linear operation levels for Normal Case 2. This deviation from linear operation becomes greatest the closer V_{SENSE} approaches 0V. Within this region, as V_{SENSE} approaches 20mV, device operation is closer to that described by Normal Case 2. [Figure 32](#) illustrates this behavior for the INA205. The V_{OUT} maximum peak for this case is tested by maintaining a constant V_S , setting $V_{SENSE} = 0mV$, and sweeping V_{CM} from 0V to V_S . The exact V_{CM} at which V_{OUT} peaks during this test varies from part to part, but the V_{OUT} maximum peak is tested to be less than the specified V_{OUT} Tested Limit.

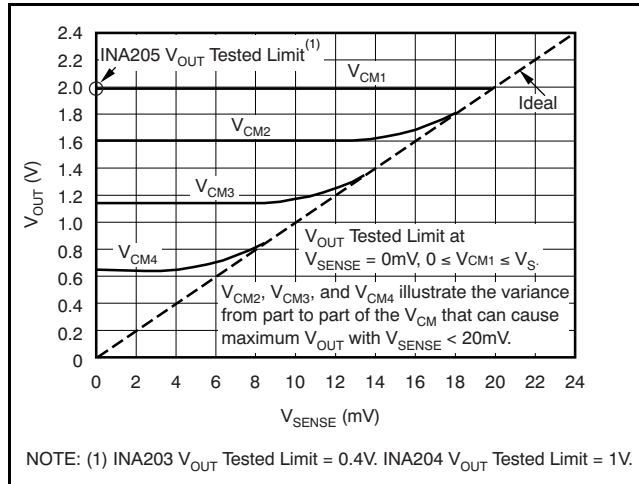

Figure 32. Example for Low V_{SENSE} Case 2 (INA205, Gain = 100)

SELECTING R_{SHUNT}

The value chosen for the shunt resistor, R_{SHUNT} , depends on the application and is a compromise between small-signal accuracy and maximum permissible voltage loss in the measurement line. High values of R_{SHUNT} provide better accuracy at lower currents by minimizing the effects of offset, while low values of R_{SHUNT} minimize voltage loss in the supply line. For most applications, best performance is attained with an R_{SHUNT} value that provides a full-scale shunt voltage range of 50mV to 100mV. Maximum input voltage for accurate measurements is $(V_{SHUNT} - 0.25)/\text{Gain}$.

TRANSIENT PROTECTION

The -16V to $+80\text{V}$ common-mode range of the INA203, INA204, and INA205 is ideal for withstanding automotive fault conditions ranging from 12V battery reversal up to $+80\text{V}$ transients, since no additional protective components are needed up to those levels. In the event that the INA203, INA204, and INA205 are exposed to transients on the inputs in excess of their ratings, then external transient absorption with semiconductor transient absorbers (zeners or *Transzorbs*) are necessary. Use of metal oxide varistors (MOVs) or video disk recorders (VDRs) is not recommended except when they are used in addition to a semiconductor transient absorber. Select the transient absorber such that it will never allow the INA203, INA204, and INA205 to be exposed to transients greater than $+80\text{V}$ (that is,

allow for transient absorber tolerance, as well as additional voltage because of transient absorber dynamic impedance). Despite the use of internal zener-type ESD protection, the INA203, INA204, and INA205 do not lend themselves to using external resistors in series with the inputs because the internal gain resistors can vary up to $\pm 30\%$ but are closely matched. (If gain accuracy is not important, then resistors can be added in series with the INA203, INA204, and INA205 inputs with two equal resistors on each input.)

OUTPUT VOLTAGE RANGE

The output of the INA203, INA204, and INA205 is accurate within the output voltage swing range set by the power-supply pin, V_+ . This performance is best illustrated when using the INA205 (a gain of 100 version), where a 100mV full-scale input from the shunt resistor requires an output voltage swing of $+10\text{V}$, and a power-supply voltage sufficient to achieve $+10\text{V}$ on the output.

INPUT FILTERING

An obvious and straightforward location for filtering is at the output of the INA203, INA204, and INA205 series; however, this location negates the advantage of the low output impedance of the internal buffer. The only other option for filtering is at the input pins of the INA203, INA204, and INA205, which is complicated by the internal $5\text{k}\Omega + 30\%$ input impedance; this configuration is illustrated in Figure 33. Using the lowest possible resistor values minimizes both the initial shift in gain and effects of tolerance. The effect on initial gain is given by Equation 3:

$$\text{Gain Error \%} = 100 - \left[100 \times \frac{5\text{k}\Omega}{5\text{k}\Omega + R_{\text{FILT}}} \right] \quad (3)$$

Total effect on gain error can be calculated by replacing the $5\text{k}\Omega$ term with $5\text{k}\Omega - 30\%$, (or $3.5\text{k}\Omega$) or $5\text{k}\Omega + 30\%$ (or $6.5\text{k}\Omega$). The tolerance extremes of R_{FILT} can also be inserted into the equation. If a pair of 100Ω 1% resistors are used on the inputs, the initial gain error will be 1.96%. Worst-case tolerance conditions will always occur at the lower excursion of the internal $5\text{k}\Omega$ resistor ($3.5\text{k}\Omega$), and the higher excursion of $R_{\text{FILT}} - 3\%$ in this case.

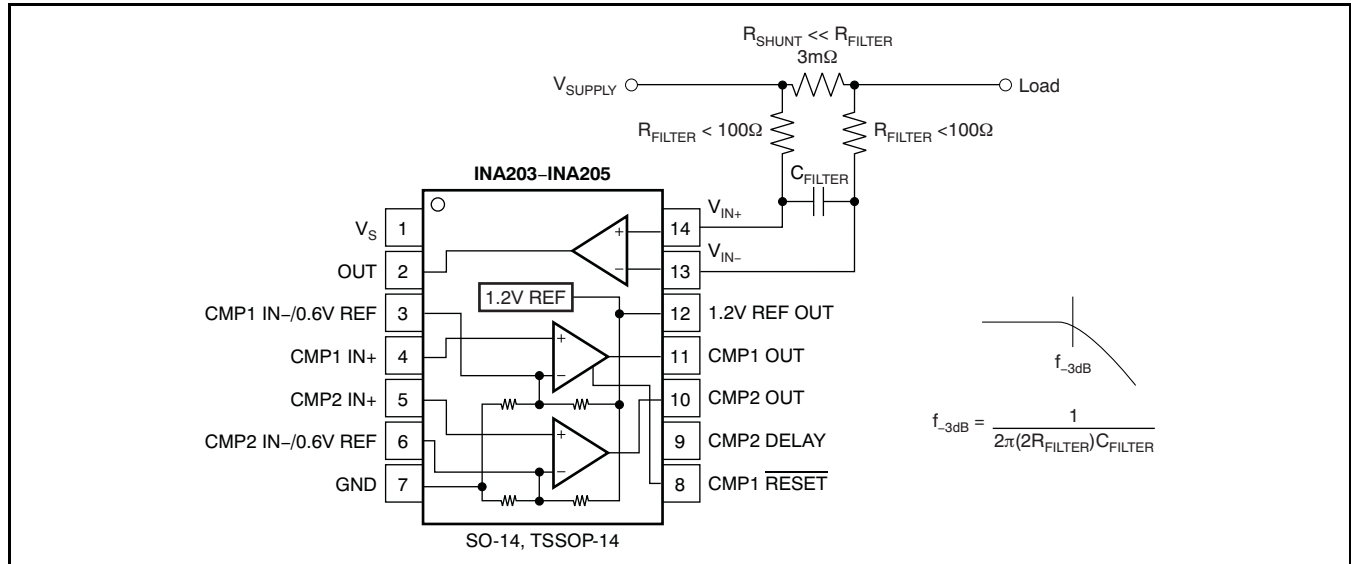

Figure 33. Input Filter (Gain Error: 1.5% to -2.2%)

Note that the specified accuracy of the INA203, INA204, and INA205 must then be combined in addition to these tolerances. While this discussion treated accuracy worst-case conditions by combining the extremes of the resistor values, it is appropriate to use geometric mean or root sum square calculations to total the effects of accuracy variations.

REFERENCE

The INA203, INA204, and INA205 include an internal voltage reference that has a load regulation of 0.4mV/mA (typical), and not more than 100ppm/°C of drift. Only the 14-pin package allows external access to reference voltages, where voltages of 1.2V and 0.6V are both available. Output current versus output voltage is illustrated in the [Typical Characteristics](#) section.

COMPARATOR

The INA203, INA204, and INA205 devices incorporate two open-drain comparators. These comparators typically have 2mV of offset and a 1.3μs (typical) response time. The output of Comparator 1 latches and is reset through the **CMP1 RESET** pin, as shown in [Figure 35](#). This configuration applies to both the 10- and 14-pin versions. [Figure 34](#) illustrates the comparator delay.

The 14-pin versions of the INA203, INA204, and INA205 include additional features for comparator functions. The comparator reference voltage of both Comparator 1 and Comparator 2 can be overridden by external inputs for increased design flexibility. Comparator 2 has a programmable delay.

COMPARATOR DELAY (14-Pin Version Only)

The Comparator 2 programmable delay is controlled by a capacitor connected to the **CMP2 Delay Pin**; see [Figure 30](#). The capacitor value (in μF) is selected by using [Equation 4](#):

$$C_{\text{DELAY}} \text{ (in } \mu\text{F)} = \frac{t_D}{5} \quad (4)$$

A simplified version of the delay circuit for Comparator 2 is shown in [Figure 34](#). The delay comparator consists of two comparator stages with the delay between them. Note that I1 and I2 cannot be turned on simultaneously; I1 corresponds to a U1 low output and I2 corresponds to a U1 high output. Using an initial assumption that the U1 output is low, I1 is on, then U2 +IN is zero. If U1 goes high, I2 supplies 120nA to C_{DELAY}. The voltage at U2 +IN begins to ramp toward a 0.6V threshold. When the voltage crosses this threshold, the U2 output goes high while the voltage at U2 +IN continues to ramp up to a maximum of 1.2V when given sufficient time (twice the value of the delay specified for C_{DELAY}). This entire sequence is reversed when the comparator outputs go low, so that returning to low exhibits the same delay.

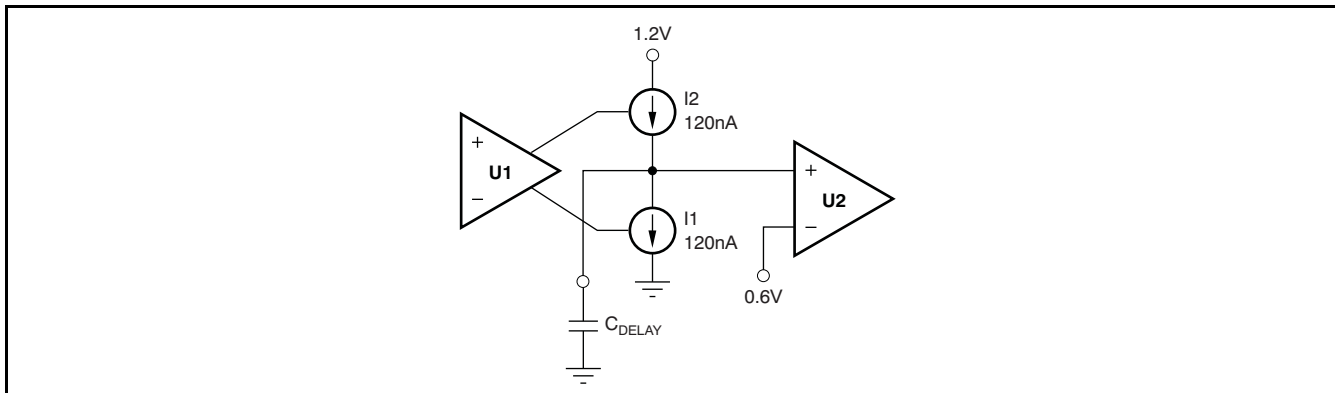

Figure 34. Simplified Model of the Comparator 2 Delay Circuit

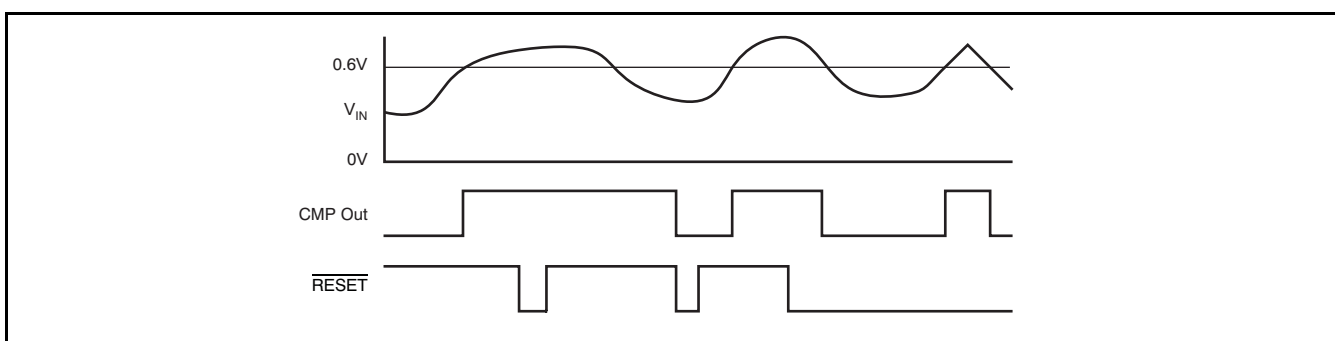

Figure 35. Comparator Latching Capability

It is important to note what will happen if events occur more rapidly than the delay timeout; for example, when the U1 output goes high (turning on I2), but returns low (turning I1 back on) prior to reaching the 0.6V transition for U2. The voltage at U2 +IN ramps back down at a rate determined by the value of C_{DELAY} , and only returns to zero if given sufficient time.

In essence, when analyzing Comparator 2 for behavior with events more rapid than its delay setting, use the model shown in Figure 34.

COMPARATOR MAXIMUM INPUT VOLTAGE RANGE

The maximum voltage at the comparator input for normal operation is up to $(V+) - 1.5V$. There are special considerations when overdriving the reference inputs (pins 3 and 6). Driving either or both inputs high enough to drive 1mA back into the reference introduces errors into the reference. Figure 36 shows the basic input structure. A general guideline is to limit the voltage on both inputs to a total of 20V. The exact limit depends on the available voltage and

whether either or both inputs are subject to the large voltage. When making this determination, consider the 20k Ω from each input back to the comparator. Figure 37 shows the maximum input voltage that avoids creating a reference error when driving both inputs (an equivalent resistance back into the reference of 10k Ω).

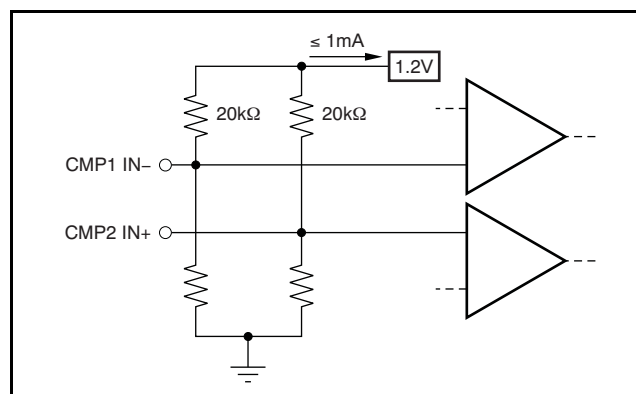

Figure 36. Limit Current Into Reference $\leq 1mA$

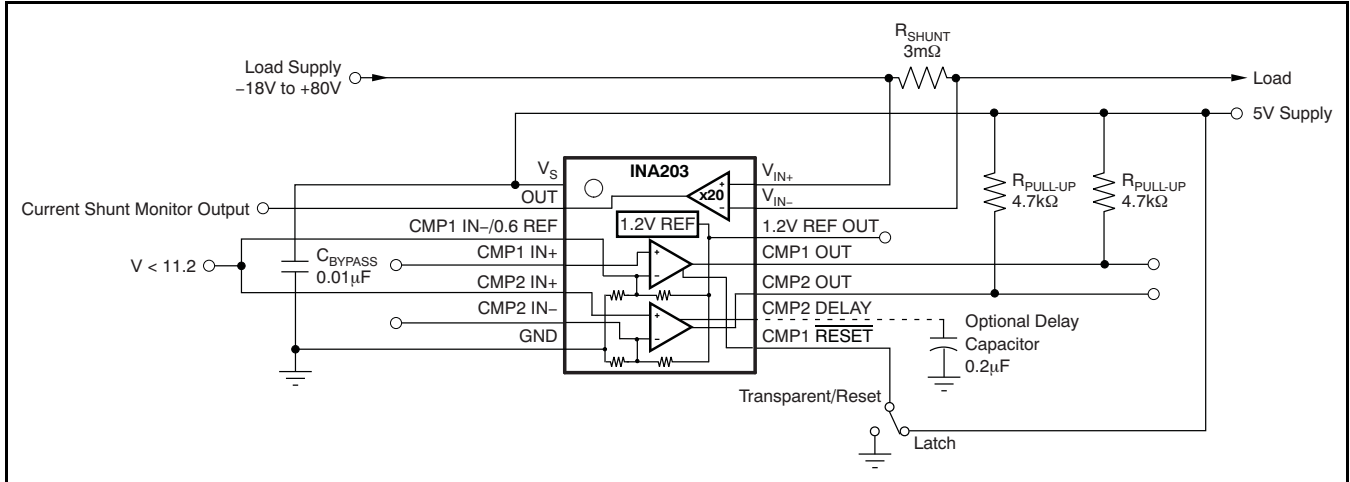

Figure 37. Overdriving Comparator Inputs Without Generating a Reference Error

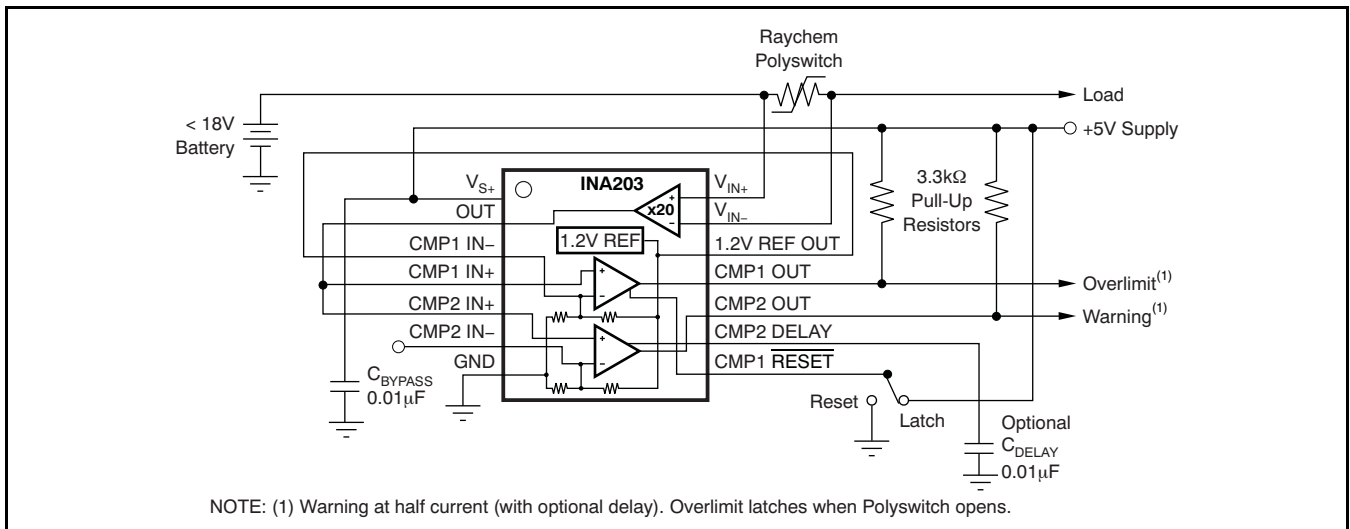

Figure 38. Polyswitch Warning and Fault Detection Circuit

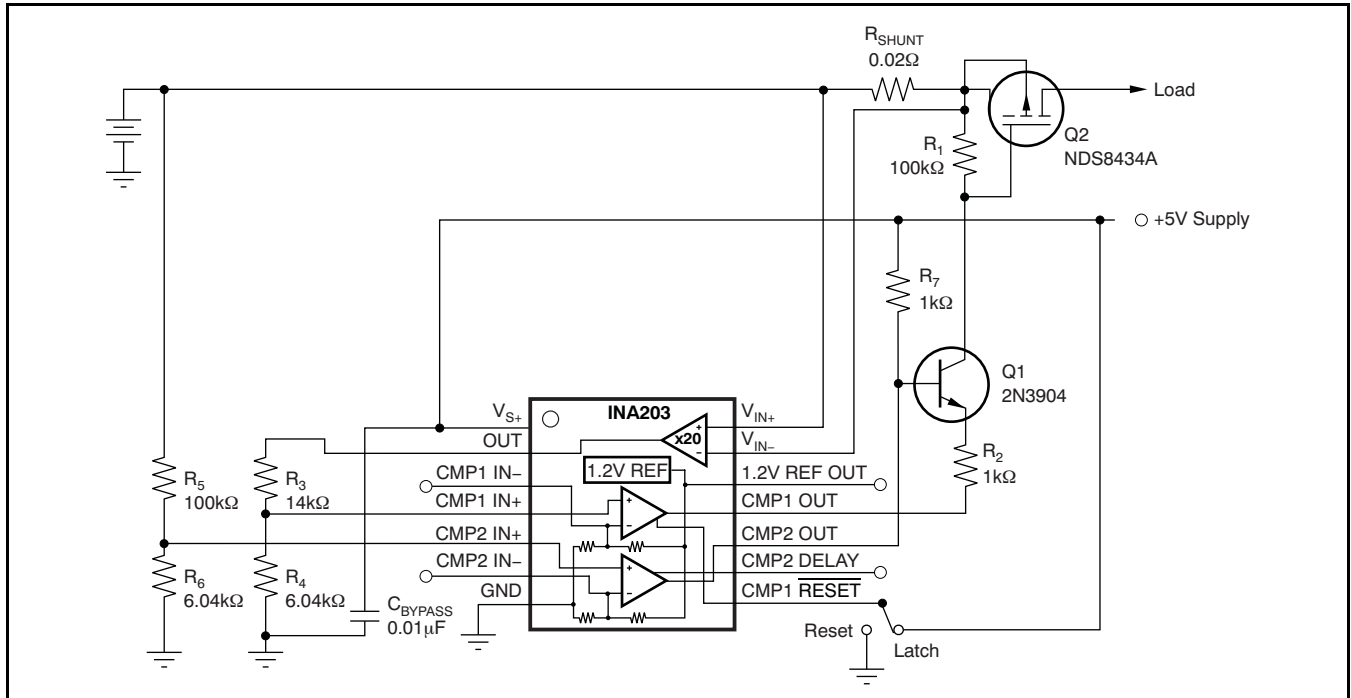

Figure 39. Lead-Acid Battery Protection Circuit

Revision History

NOTE: Page numbers for previous revisions may differ from page numbers in the current version.

Changes from Revision C (October 2007) to Revision D	Page
• Changed Figure 1	4

PACKAGING INFORMATION

Orderable Device	Status (1)	Package Type	Package Drawing	Pins	Package Qty	Eco Plan (2)	Lead/Ball Finish (6)	MSL Peak Temp (3)	Op Temp (°C)	Device Marking (4/5)	Samples
INA203AID	ACTIVE	SOIC	D	14	50	Green (RoHS & no Sb/Br)	CU NIPDAU	Level-2-260C-1 YEAR	-40 to 125	INA203A	Samples
INA203AIDGSR	ACTIVE	VSSOP	DGS	10	2500	Green (RoHS & no Sb/Br)	CU NIPDAU CU NIPDAUAG	Level-2-260C-1 YEAR	-40 to 125	BQN	Samples
INA203AIDGSRG4	ACTIVE	VSSOP	DGS	10	2500	Green (RoHS & no Sb/Br)	CU NIPDAU	Level-2-260C-1 YEAR	-40 to 125	BQN	Samples
INA203AIDGST	ACTIVE	VSSOP	DGS	10	250	Green (RoHS & no Sb/Br)	CU NIPDAU CU NIPDAUAG	Level-2-260C-1 YEAR	-40 to 125	BQN	Samples
INA203AIDGSTG4	ACTIVE	VSSOP	DGS	10	250	Green (RoHS & no Sb/Br)	CU NIPDAU	Level-2-260C-1 YEAR	-40 to 125	BQN	Samples
INA203AIDR	ACTIVE	SOIC	D	14	2500	Green (RoHS & no Sb/Br)	CU NIPDAU	Level-2-260C-1 YEAR	-40 to 125	INA203A	Samples
INA203AIPW	ACTIVE	TSSOP	PW	14	90	Green (RoHS & no Sb/Br)	CU NIPDAU	Level-2-260C-1 YEAR	-40 to 125	INA203A	Samples
INA203AIPWR	ACTIVE	TSSOP	PW	14	2000	Green (RoHS & no Sb/Br)	CU NIPDAU	Level-2-260C-1 YEAR	-40 to 125	INA203A	Samples
INA204AID	ACTIVE	SOIC	D	14	50	Green (RoHS & no Sb/Br)	CU NIPDAU	Level-2-260C-1 YEAR	-40 to 125	INA204A	Samples
INA204AIDGSR	ACTIVE	VSSOP	DGS	10	2500	Green (RoHS & no Sb/Br)	CU NIPDAUAG	Level-2-260C-1 YEAR	-40 to 125	BQO	Samples
INA204AIDGSRG4	ACTIVE	VSSOP	DGS	10	2500	Green (RoHS & no Sb/Br)	CU NIPDAUAG	Level-2-260C-1 YEAR	-40 to 125	BQO	Samples
INA204AIDGST	ACTIVE	VSSOP	DGS	10	250	Green (RoHS & no Sb/Br)	CU NIPDAU CU NIPDAUAG	Level-2-260C-1 YEAR	-40 to 125	BQO	Samples
INA204AIDGSTG4	ACTIVE	VSSOP	DGS	10	250	Green (RoHS & no Sb/Br)	CU NIPDAU	Level-2-260C-1 YEAR	-40 to 125	BQO	Samples
INA204AIDR	ACTIVE	SOIC	D	14	2500	Green (RoHS & no Sb/Br)	CU NIPDAU	Level-2-260C-1 YEAR	-40 to 125	INA204A	Samples
INA204AIPW	ACTIVE	TSSOP	PW	14	90	Green (RoHS & no Sb/Br)	CU NIPDAU	Level-2-260C-1 YEAR	-40 to 125	INA204A	Samples
INA204AIPWR	ACTIVE	TSSOP	PW	14	2000	Green (RoHS & no Sb/Br)	CU NIPDAU	Level-2-260C-1 YEAR	-40 to 125	INA204A	Samples
INA205AID	ACTIVE	SOIC	D	14	50	Green (RoHS & no Sb/Br)	CU NIPDAU	Level-2-260C-1 YEAR	-40 to 125	INA205A	Samples

Orderable Device	Status (1)	Package Type	Package Drawing	Pins	Package Qty	Eco Plan (2)	Lead/Ball Finish (6)	MSL Peak Temp (3)	Op Temp (°C)	Device Marking (4/5)	Samples
INA205AIDGSR	ACTIVE	VSSOP	DGS	10	2500	Green (RoHS & no Sb/Br)	CU NIPDAU CU NIPDAUAG	Level-2-260C-1 YEAR	-40 to 125	BQP	Samples
INA205AIDGSRG4	ACTIVE	VSSOP	DGS	10	2500	Green (RoHS & no Sb/Br)	CU NIPDAU	Level-2-260C-1 YEAR	-40 to 125	BQP	Samples
INA205AIDGST	ACTIVE	VSSOP	DGS	10	250	Green (RoHS & no Sb/Br)	CU NIPDAU CU NIPDAUAG	Level-2-260C-1 YEAR	-40 to 125	BQP	Samples
INA205AIDR	ACTIVE	SOIC	D	14	2500	Green (RoHS & no Sb/Br)	CU NIPDAU	Level-2-260C-1 YEAR	-40 to 125	INA205A	Samples
INA205AIPW	ACTIVE	TSSOP	PW	14	90	Green (RoHS & no Sb/Br)	CU NIPDAU	Level-2-260C-1 YEAR	-40 to 125	INA205A	Samples
INA205AIPWR	ACTIVE	TSSOP	PW	14	2000	Green (RoHS & no Sb/Br)	CU NIPDAU	Level-2-260C-1 YEAR	-40 to 125	INA205A	Samples

(1) The marketing status values are defined as follows:

ACTIVE: Product device recommended for new designs.

LIFEBUY: TI has announced that the device will be discontinued, and a lifetime-buy period is in effect.

NRND: Not recommended for new designs. Device is in production to support existing customers, but TI does not recommend using this part in a new design.

PREVIEW: Device has been announced but is not in production. Samples may or may not be available.

OBSELETE: TI has discontinued the production of the device.

(2) Eco Plan - The planned eco-friendly classification: Pb-Free (RoHS), Pb-Free (RoHS Exempt), or Green (RoHS & no Sb/Br) - please check <http://www.ti.com/productcontent> for the latest availability information and additional product content details.

TBD: The Pb-Free/Green conversion plan has not been defined.

Pb-Free (RoHS): TI's terms "Lead-Free" or "Pb-Free" mean semiconductor products that are compatible with the current RoHS requirements for all 6 substances, including the requirement that lead not exceed 0.1% by weight in homogeneous materials. Where designed to be soldered at high temperatures, TI Pb-Free products are suitable for use in specified lead-free processes.

Pb-Free (RoHS Exempt): This component has a RoHS exemption for either 1) lead-based flip-chip solder bumps used between the die and package, or 2) lead-based die adhesive used between the die and leadframe. The component is otherwise considered Pb-Free (RoHS compatible) as defined above.

Green (RoHS & no Sb/Br): TI defines "Green" to mean Pb-Free (RoHS compatible), and free of Bromine (Br) and Antimony (Sb) based flame retardants (Br or Sb do not exceed 0.1% by weight in homogeneous material)

(3) MSL, Peak Temp. - The Moisture Sensitivity Level rating according to the JEDEC industry standard classifications, and peak solder temperature.

(4) There may be additional marking, which relates to the logo, the lot trace code information, or the environmental category on the device.

(5) Multiple Device Markings will be inside parentheses. Only one Device Marking contained in parentheses and separated by a "-" will appear on a device. If a line is indented then it is a continuation of the previous line and the two combined represent the entire Device Marking for that device.

⁽⁶⁾ Lead/Ball Finish - Orderable Devices may have multiple material finish options. Finish options are separated by a vertical ruled line. Lead/Ball Finish values may wrap to two lines if the finish value exceeds the maximum column width.

Important Information and Disclaimer:The information provided on this page represents TI's knowledge and belief as of the date that it is provided. TI bases its knowledge and belief on information provided by third parties, and makes no representation or warranty as to the accuracy of such information. Efforts are underway to better integrate information from third parties. TI has taken and continues to take reasonable steps to provide representative and accurate information but may not have conducted destructive testing or chemical analysis on incoming materials and chemicals. TI and TI suppliers consider certain information to be proprietary, and thus CAS numbers and other limited information may not be available for release.

In no event shall TI's liability arising out of such information exceed the total purchase price of the TI part(s) at issue in this document sold by TI to Customer on an annual basis.

OTHER QUALIFIED VERSIONS OF INA203 :

- Automotive: [INA203-Q1](#)

NOTE: Qualified Version Definitions:

- Automotive - Q100 devices qualified for high-reliability automotive applications targeting zero defects

TAPE AND REEL INFORMATION

QUADRANT ASSIGNMENTS FOR PIN 1 ORIENTATION IN TAPE

*All dimensions are nominal

Device	Package Type	Package Drawing	Pins	SPQ	Reel Diameter (mm)	Reel Width W1 (mm)	A0 (mm)	B0 (mm)	K0 (mm)	P1 (mm)	W (mm)	Pin1 Quadrant
INA203AIDGSR	VSSOP	DGS	10	2500	330.0	12.4	5.3	3.4	1.4	8.0	12.0	Q1
INA203AIDGST	VSSOP	DGS	10	250	180.0	12.4	5.3	3.4	1.4	8.0	12.0	Q1
INA203AIDR	SOIC	D	14	2500	330.0	16.4	6.5	9.0	2.1	8.0	16.0	Q1
INA203AIPWR	TSSOP	PW	14	2000	330.0	12.4	6.9	5.6	1.6	8.0	12.0	Q1
INA204AIDGSR	VSSOP	DGS	10	2500	330.0	12.4	5.3	3.4	1.4	8.0	12.0	Q1
INA204AIDGST	VSSOP	DGS	10	250	180.0	12.4	5.3	3.4	1.4	8.0	12.0	Q1
INA204AIDR	SOIC	D	14	2500	330.0	16.4	6.5	9.0	2.1	8.0	16.0	Q1
INA204AIPWR	TSSOP	PW	14	2000	330.0	12.4	6.9	5.6	1.6	8.0	12.0	Q1
INA205AIDGSR	VSSOP	DGS	10	2500	330.0	12.4	5.3	3.4	1.4	8.0	12.0	Q1
INA205AIDGST	VSSOP	DGS	10	250	180.0	12.4	5.3	3.4	1.4	8.0	12.0	Q1
INA205AIDR	SOIC	D	14	2500	330.0	16.4	6.5	9.0	2.1	8.0	16.0	Q1
INA205AIPWR	TSSOP	PW	14	2000	330.0	12.4	6.9	5.6	1.6	8.0	12.0	Q1

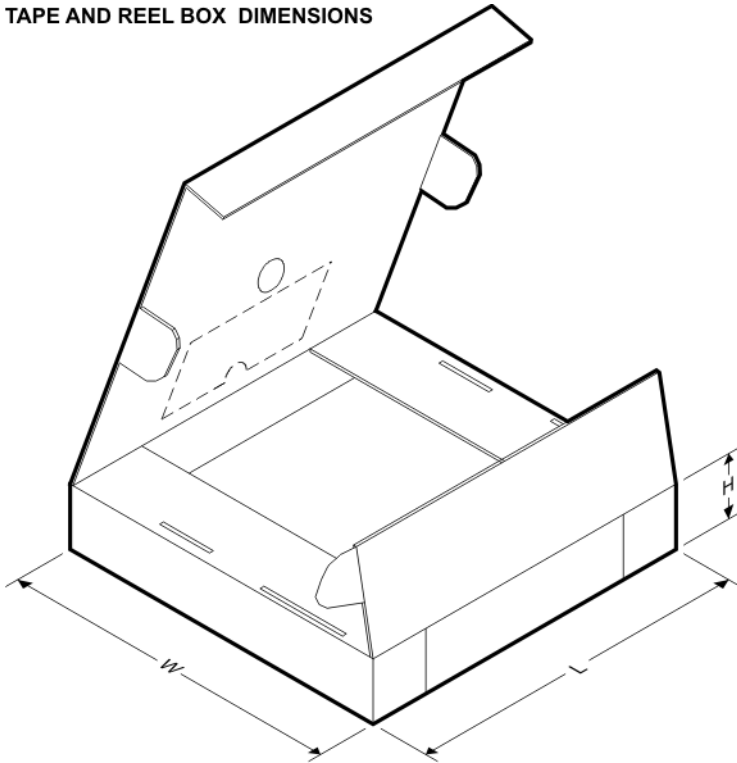
TAPE AND REEL BOX DIMENSIONS

*All dimensions are nominal

Device	Package Type	Package Drawing	Pins	SPQ	Length (mm)	Width (mm)	Height (mm)
INA203AIDGSR	VSSOP	DGS	10	2500	367.0	367.0	35.0
INA203AIDGST	VSSOP	DGS	10	250	210.0	185.0	35.0
INA203AIDR	SOIC	D	14	2500	367.0	367.0	38.0
INA203AIPWR	TSSOP	PW	14	2000	367.0	367.0	35.0
INA204AIDGSR	VSSOP	DGS	10	2500	367.0	367.0	35.0
INA204AIDGST	VSSOP	DGS	10	250	210.0	185.0	35.0
INA204AIDR	SOIC	D	14	2500	367.0	367.0	38.0
INA204AIPWR	TSSOP	PW	14	2000	367.0	367.0	35.0
INA205AIDGSR	VSSOP	DGS	10	2500	367.0	367.0	35.0
INA205AIDGST	VSSOP	DGS	10	250	210.0	185.0	35.0
INA205AIDR	SOIC	D	14	2500	367.0	367.0	38.0
INA205AIPWR	TSSOP	PW	14	2000	367.0	367.0	35.0

DGS (S-PDSO-G10)

PLASTIC SMALL-OUTLINE PACKAGE

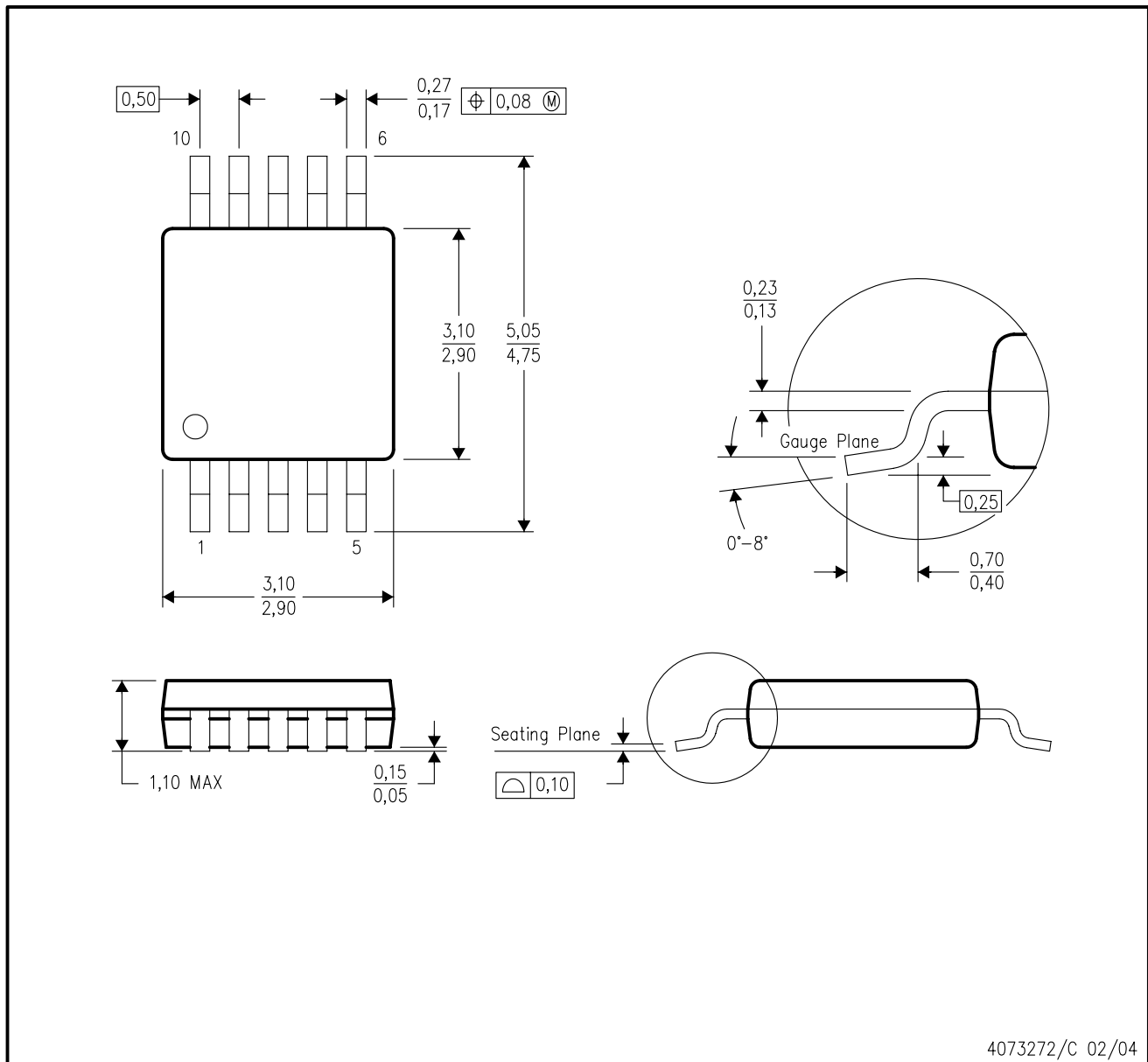

- NOTES:
- A. All linear dimensions are in millimeters.
 - B. This drawing is subject to change without notice.
 - C. Body dimensions do not include mold flash or protrusion.
 - D. Falls within JEDEC MO-187 variation BA.

DGS (S-PDSO-G10)

PLASTIC SMALL OUTLINE PACKAGE

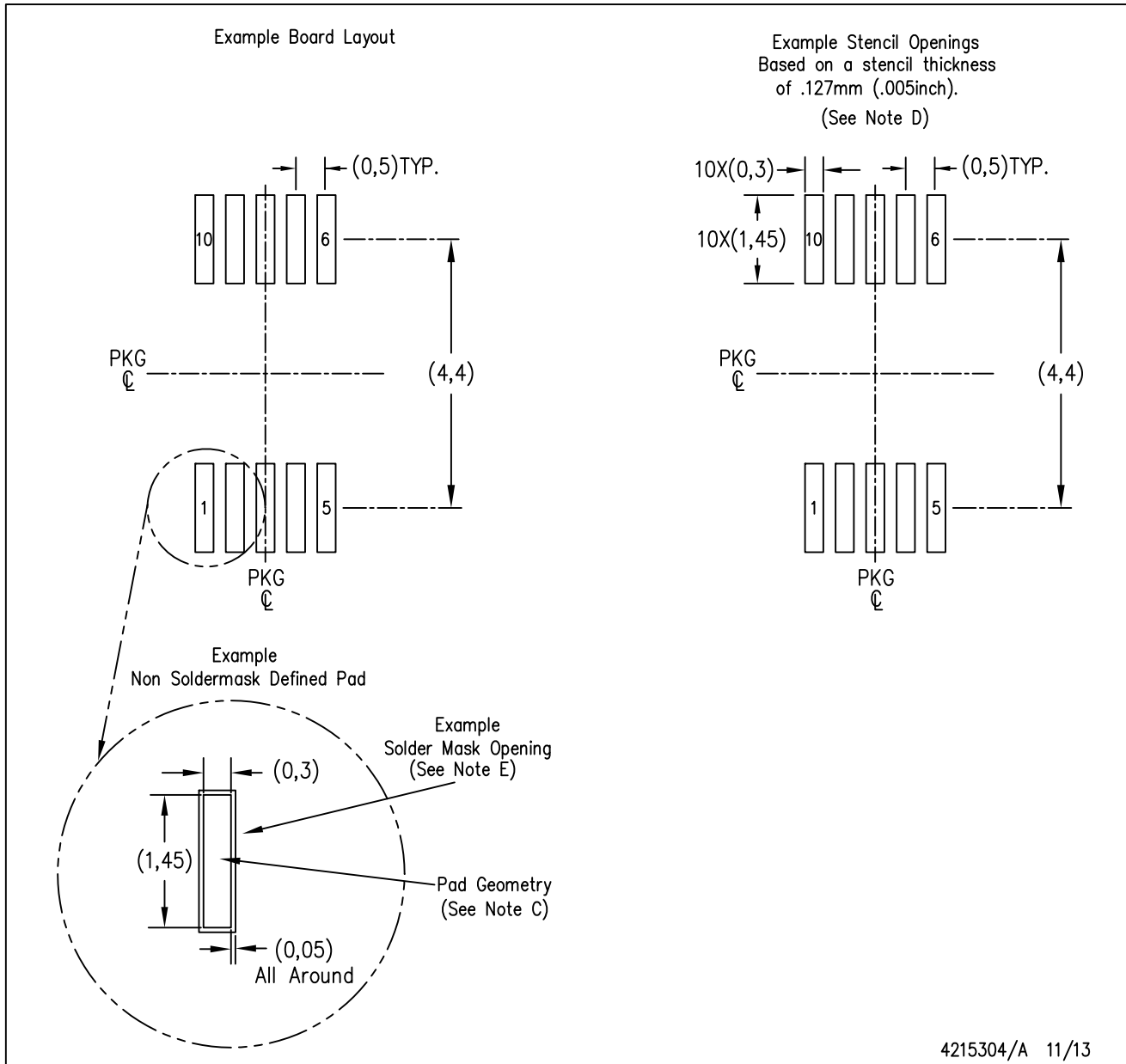

- NOTES:
- A. All linear dimensions are in millimeters.
 - B. This drawing is subject to change without notice.
 - C. Publication IPC-7351 is recommended for alternate designs.
 - D. Laser cutting apertures with trapezoidal walls and also rounding corners will offer better paste release. Customers should contact their board assembly site for stencil design recommendations. Refer to IPC-7525 for other stencil recommendations.
 - E. Customers should contact their board fabrication site for solder mask tolerances between and around signal pads.

D (R-PDSO-G14)

PLASTIC SMALL OUTLINE





- NOTES:
- All linear dimensions are in millimeters.
 - This drawing is subject to change without notice.
 - Publication IPC-7351 is recommended for alternate designs.
 - Laser cutting apertures with trapezoidal walls and also rounding corners will offer better paste release. Customers should contact their board assembly site for stencil design recommendations. Refer to IPC-7525 for other stencil recommendations.
 - Customers should contact their board fabrication site for solder mask tolerances between and around signal pads.

PW (R-PDSO-G14)

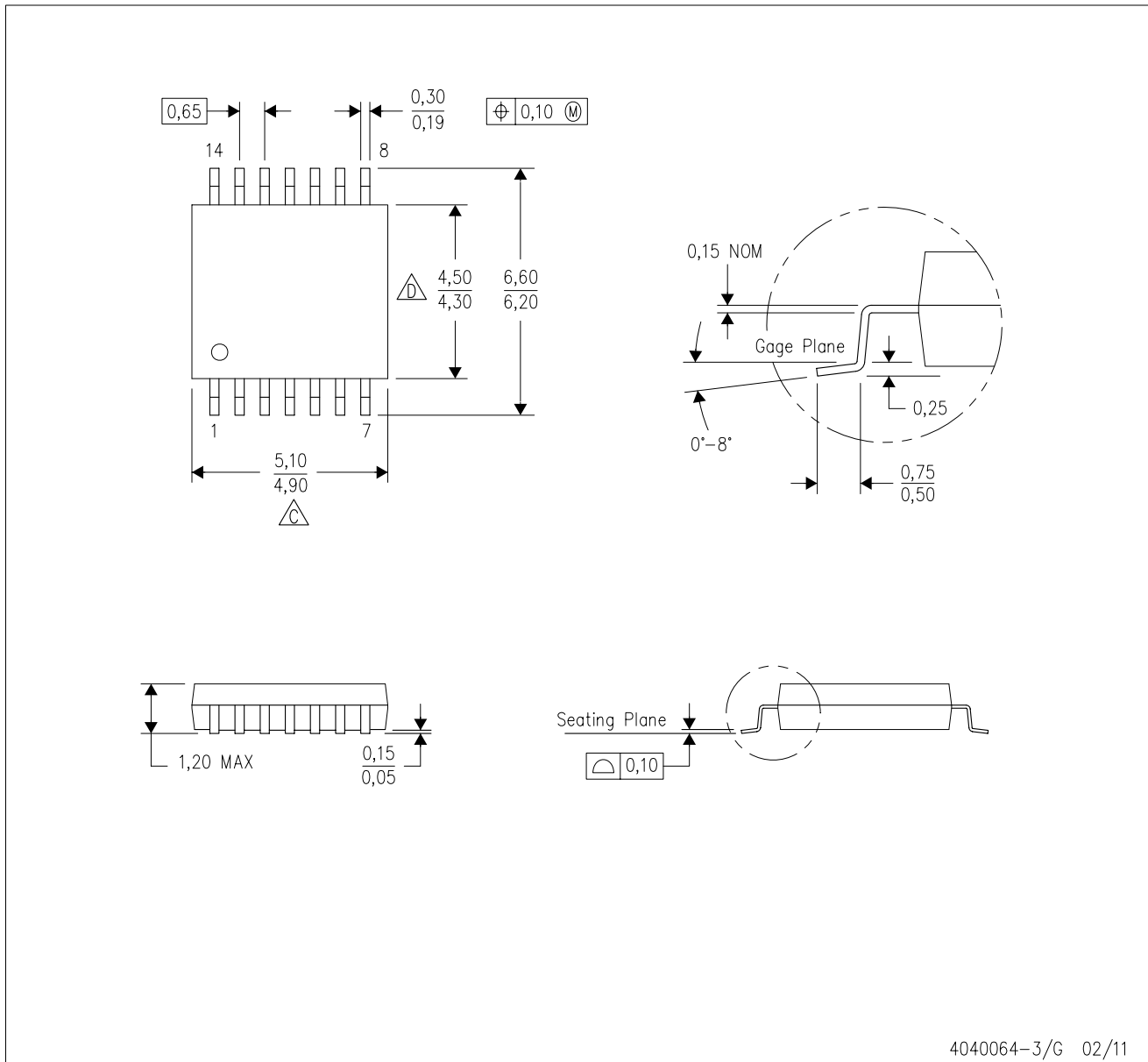
PLASTIC SMALL OUTLINE



4040064-3/G 02/11

- NOTES:
- A. All linear dimensions are in millimeters. Dimensioning and tolerancing per ASME Y14.5M-1994.
 - B. This drawing is subject to change without notice.
 -  C. Body length does not include mold flash, protrusions, or gate burrs. Mold flash, protrusions, or gate burrs shall not exceed 0,15 each side.
 -  D. Body width does not include interlead flash. Interlead flash shall not exceed 0,25 each side.
 - E. Falls within JEDEC MO-153

PW (R-PDSO-G14)

PLASTIC SMALL OUTLINE

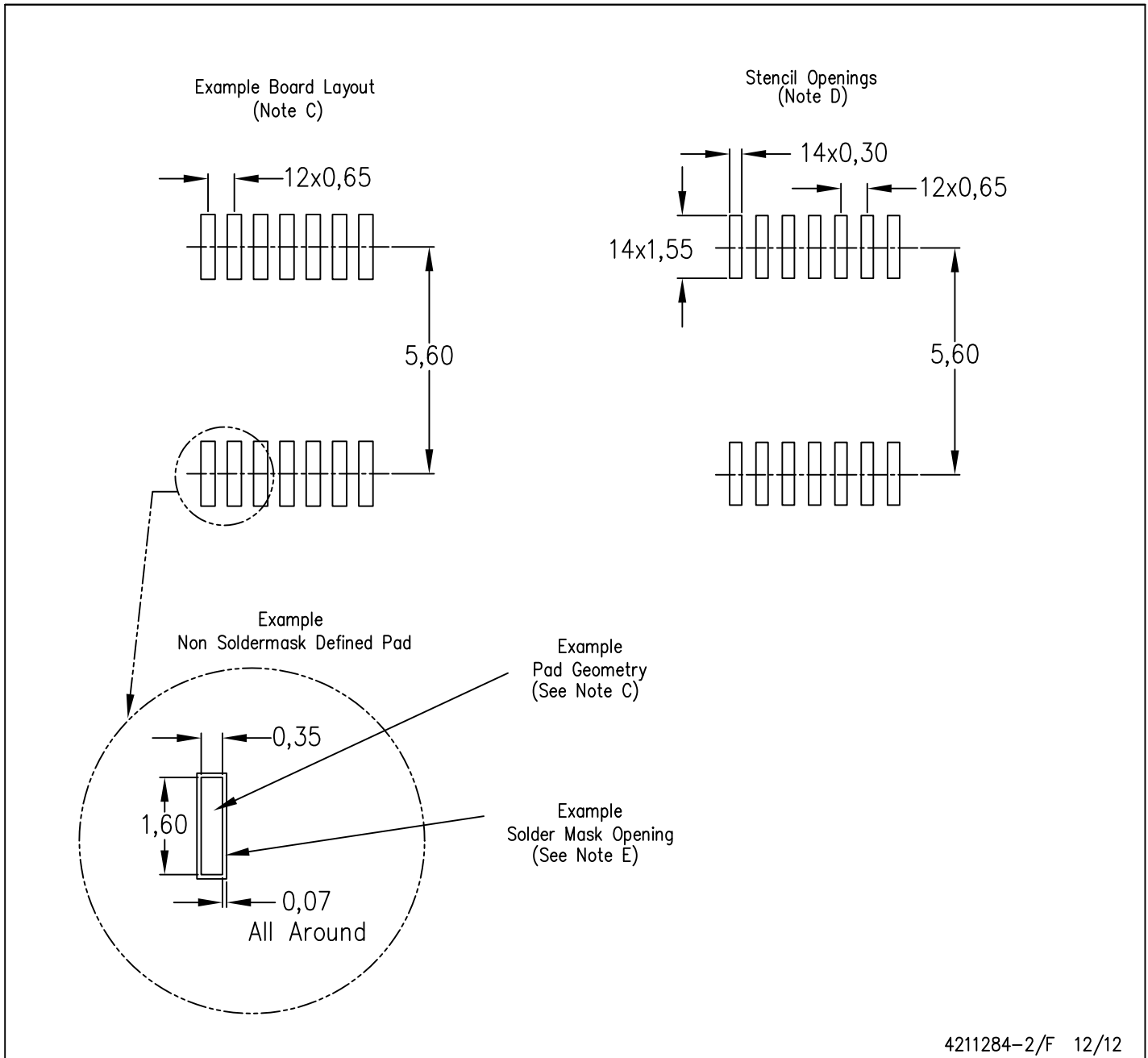

- NOTES:
- All linear dimensions are in millimeters.
 - This drawing is subject to change without notice.
 - Publication IPC-7351 is recommended for alternate designs.
 - Laser cutting apertures with trapezoidal walls and also rounding corners will offer better paste release. Customers should contact their board assembly site for stencil design recommendations. Refer to IPC-7525 for other stencil recommendations.
 - Customers should contact their board fabrication site for solder mask tolerances between and around signal pads.

IMPORTANT NOTICE

Texas Instruments Incorporated and its subsidiaries (TI) reserve the right to make corrections, enhancements, improvements and other changes to its semiconductor products and services per JESD46, latest issue, and to discontinue any product or service per JESD48, latest issue. Buyers should obtain the latest relevant information before placing orders and should verify that such information is current and complete. All semiconductor products (also referred to herein as "components") are sold subject to TI's terms and conditions of sale supplied at the time of order acknowledgment.

TI warrants performance of its components to the specifications applicable at the time of sale, in accordance with the warranty in TI's terms and conditions of sale of semiconductor products. Testing and other quality control techniques are used to the extent TI deems necessary to support this warranty. Except where mandated by applicable law, testing of all parameters of each component is not necessarily performed.

TI assumes no liability for applications assistance or the design of Buyers' products. Buyers are responsible for their products and applications using TI components. To minimize the risks associated with Buyers' products and applications, Buyers should provide adequate design and operating safeguards.

TI does not warrant or represent that any license, either express or implied, is granted under any patent right, copyright, mask work right, or other intellectual property right relating to any combination, machine, or process in which TI components or services are used. Information published by TI regarding third-party products or services does not constitute a license to use such products or services or a warranty or endorsement thereof. Use of such information may require a license from a third party under the patents or other intellectual property of the third party, or a license from TI under the patents or other intellectual property of TI.

Reproduction of significant portions of TI information in TI data books or data sheets is permissible only if reproduction is without alteration and is accompanied by all associated warranties, conditions, limitations, and notices. TI is not responsible or liable for such altered documentation. Information of third parties may be subject to additional restrictions.

Resale of TI components or services with statements different from or beyond the parameters stated by TI for that component or service voids all express and any implied warranties for the associated TI component or service and is an unfair and deceptive business practice. TI is not responsible or liable for any such statements.

Buyer acknowledges and agrees that it is solely responsible for compliance with all legal, regulatory and safety-related requirements concerning its products, and any use of TI components in its applications, notwithstanding any applications-related information or support that may be provided by TI. Buyer represents and agrees that it has all the necessary expertise to create and implement safeguards which anticipate dangerous consequences of failures, monitor failures and their consequences, lessen the likelihood of failures that might cause harm and take appropriate remedial actions. Buyer will fully indemnify TI and its representatives against any damages arising out of the use of any TI components in safety-critical applications.

In some cases, TI components may be promoted specifically to facilitate safety-related applications. With such components, TI's goal is to help enable customers to design and create their own end-product solutions that meet applicable functional safety standards and requirements. Nonetheless, such components are subject to these terms.

No TI components are authorized for use in FDA Class III (or similar life-critical medical equipment) unless authorized officers of the parties have executed a special agreement specifically governing such use.

Only those TI components which TI has specifically designated as military grade or "enhanced plastic" are designed and intended for use in military/aerospace applications or environments. Buyer acknowledges and agrees that any military or aerospace use of TI components which have **not** been so designated is solely at the Buyer's risk, and that Buyer is solely responsible for compliance with all legal and regulatory requirements in connection with such use.

TI has specifically designated certain components as meeting ISO/TS16949 requirements, mainly for automotive use. In any case of use of non-designated products, TI will not be responsible for any failure to meet ISO/TS16949.

Products

Audio	www.ti.com/audio
Amplifiers	amplifier.ti.com
Data Converters	dataconverter.ti.com
DLP® Products	www.dlp.com
DSP	dsp.ti.com
Clocks and Timers	www.ti.com/clocks
Interface	interface.ti.com
Logic	logic.ti.com
Power Mgmt	power.ti.com
Microcontrollers	microcontroller.ti.com
RFID	www.ti-rfid.com
OMAP Applications Processors	www.ti.com/omap
Wireless Connectivity	www.ti.com/wirelessconnectivity

Applications

Automotive and Transportation	www.ti.com/automotive
Communications and Telecom	www.ti.com/communications
Computers and Peripherals	www.ti.com/computers
Consumer Electronics	www.ti.com/consumer-apps
Energy and Lighting	www.ti.com/energy
Industrial	www.ti.com/industrial
Medical	www.ti.com/medical
Security	www.ti.com/security
Space, Avionics and Defense	www.ti.com/space-avionics-defense
Video and Imaging	www.ti.com/video

TI E2E Community

e2e.ti.com